



# GMV5

GREE Multi VRF 5



EU



## GREE ELECTRIC APPLIANCES, INC. OF ZHUHAI

Add: West Jinji Rd, Qianshan, Zhuhai, Guangdong, China 519070  
Tel: (+86-756) 852 2218 Fax: (+86-756) 866 9426  
Email: gree@gree.com.cn Http://www.gree.com

## HONG KONG GREE ELECTRIC APPLIANCES SALES LIMITED

Add: Unit 2612, 26/F, Mira Place Tower A, 132 Nathan Road, Tsimshatsui, Kowloon, HK  
Tel: (852) 3165 8898 Fax: (852) 3165 1029

**Note:**  
Gree is committed to continuously improving its products to ensure the highest quality and reliability standards, and to meet local regulations and market requirements.

All features and specifications are subject to change without prior notice.

All images provided in this catalogue are used for illustration purposes only.  
Copyright© Gree Electric Appliances, Inc. of Zhuhai. All rights reserved.

GC-1706-04(EU VERSION)



Distributor information



# CONTENTS

- 01 GMV5E
- 20 GMV5 Mini & Slim
- 29 GMV5 Heat Recovery
- 42 Indoor Units
- 67 Control System



**GMV5E** DC Inverter Multi VRF System with its high-efficient inverter compressors has four exciting features which are different from those found on traditional inverter air conditioners: excellent energy-saving effect, more reliable and precise operation, smarter network control, providing users with best air conditioning experience.





# GMV5E



## Key Features

### All DC Inverter Technology to Improve Compression Efficiency

All DC inverter compressor and high-performance high pressure chamber are adopted to reduce loss of overheat and improve compression efficiency from direct intake. Compared with low pressure chamber, the compression efficiency is improved. High-efficient permasyon motor is adopted to provide better performance than traditional DC inverter compressor.

### All DC Inverter Compressor

- All DC inverter compressor is used in this system. It can directly intake gas to reduce loss of overheat and improve efficiency.

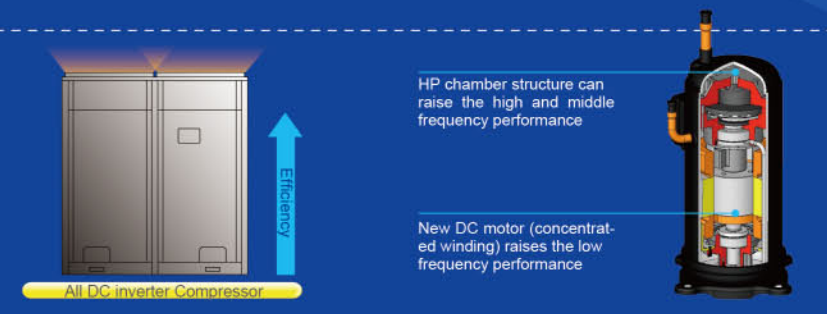

- High-efficient permasyon motor is adopted to provide better performance than traditional DC inverter compressor.

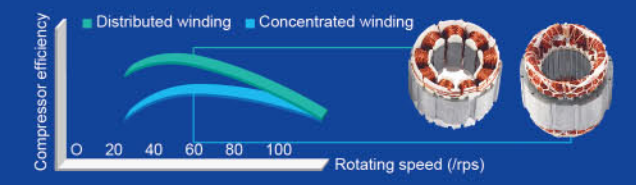

### Technology of Maximum Torque Control with Minimum Current

It can reduce energy loss caused by device winding so as to realize higher efficiency.

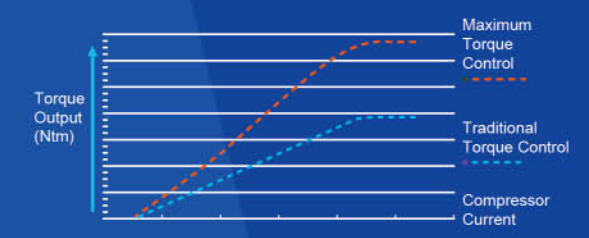

- 180° Sine Wave DC Speed Varying Technology It can satisfy various places' demands for different temperature and is able to save a great deal of electricity and provide users with utmost comfort at the same time.

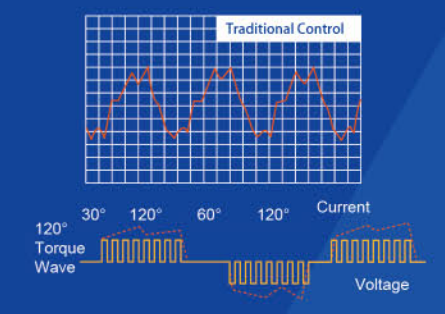

### Low-frequency Torque Control

It can directly control motor torque, through which fan motor can run at a low speed. Users will feel more comfortable while requirements of the system are also met.

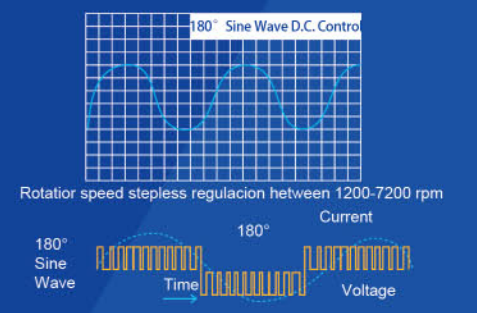
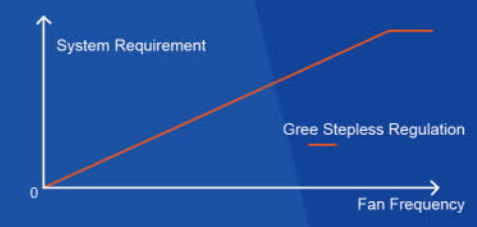



## Sensorless DC Inverter Fan Motor

- Stepless speed regulation ranges from **5Hz** to **65Hz**. Compared with traditional inverter motors, the operation is more energy-saving.

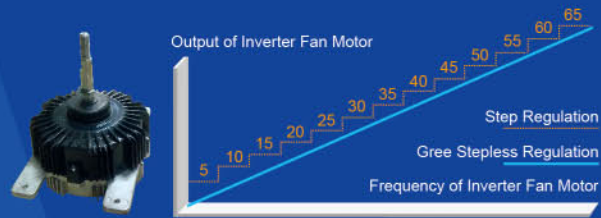

- Sensorless control technology guarantees lower noise, less vibration and steadier operation.

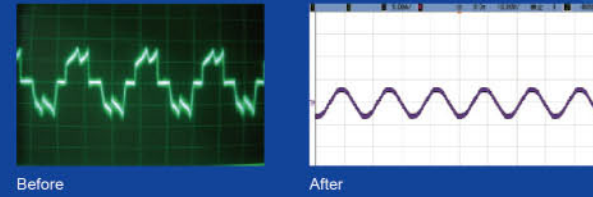

## 88HP Max Capacity-The Largest Free Combination

Max capacity of single outdoor unit reaches **22HP** and max combination capacity is even up to **88HP**, in an industry leading level.

Max combination capacity is extended to 88HP



8/10 HP

12/14/16 HP\*

16/18/20/22 HP

**88HP**

Note\*: 16HP outdoor unit has different appearance for different model.

Money is saved in system cost and piping



## Compact design

With compact design, the outdoor unit can be carried to the roof of building through elevator, with no need of crane. It is easier for delivery and installation.



## Non-polar CAN Technology to Improve Communication Efficiency

- Gree is the first one to adopt non-polar CAN communication technology in the industry. CAN communication technology provides quicker system response speed, more convenient installation debugging and more reliable communication data.

Performance Index	Company A Multi-VRF Network	GMV5E DC Inverter CAN Network
Reliability	Software check	Hardware check, more reliable
	One unit's communication error may lead to a breakdown of the whole network	If one unit has errors, it will exit from the network without any influence to other units.
Communication Efficiency	Low utilization	High utilization
	Communication speed is about 10Kbps.	Communication speed is 20Kbps.
Compatibility	One main network, difficult to add new equipment	Multiple main networks, easy to add new equipment.
Communication Distance	1000m	1500m

- The non-polar CAN communication technology is applied to support flexible wiring installation, greatly reducing construction difficulties.





## Wide Range of Voltage and Operation Condition

Working voltage range of GMV5E system has been improved to **320V~460V**, which surpasses the national standard of 342V~420V. For places with unsteady voltage, this system can still be running well.



Outdoor operation temperature range is improved to **-5°C~52°C in cooling** and **-20°C~24°C in heating**.



## Wider Applicable Location

GMV5E can realize a combination of 4 outdoor unit modules connecting with as many as **80** indoor units. It's especially applicable for business building or hotels.



## Refrigerant Storage and Distribution

The GMV5E system is designed without liquid receiver and the excess refrigerant is stored in the piping, which can minimize the refrigerant charging volume and enhance the control accuracy of refrigerant.

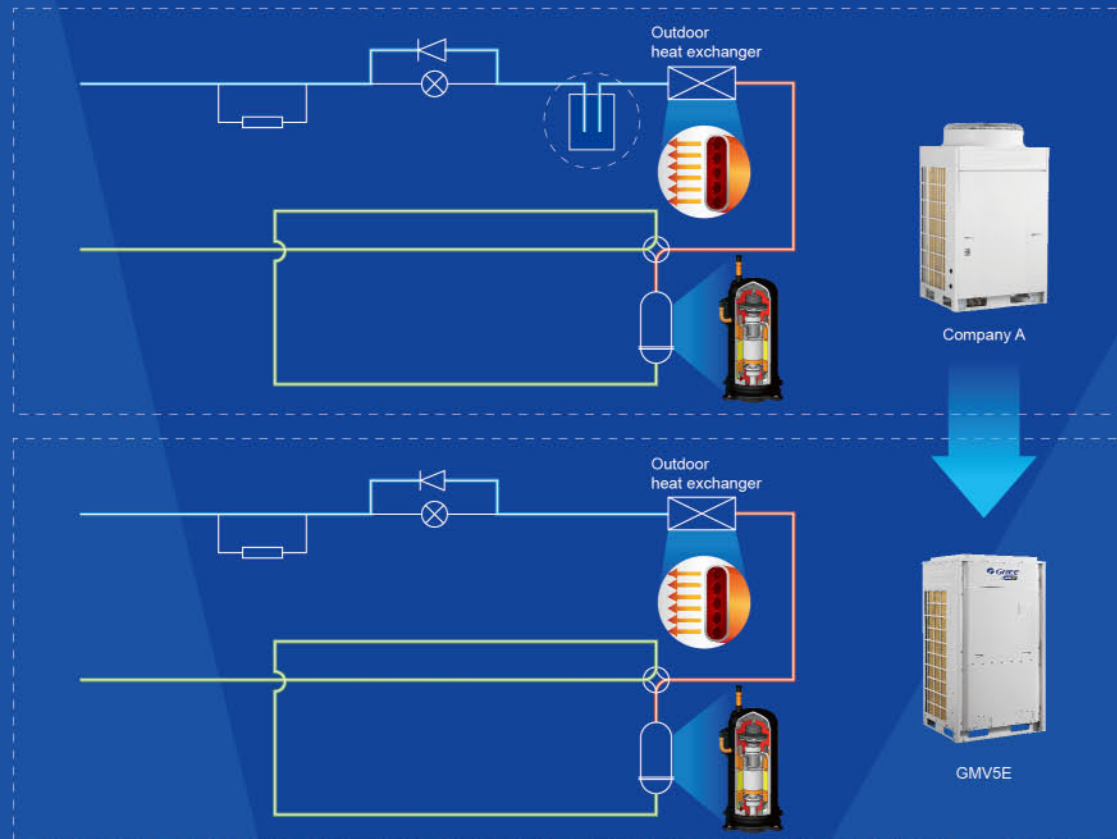

## High Efficiency and More Energy Saving

Thanks to the advanced all DC inverter technology, optimized system design and accurate intelligent control technology, EER of GMV5E is up to 4.73 while COP is up to 5.56.

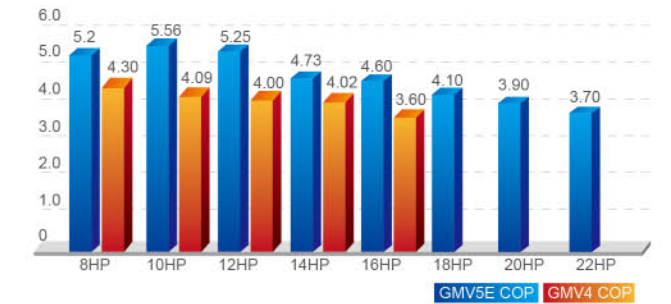

## New Generation of Energy-saving Operation Control Technology with Energy Saving Up to 20%

The GMV5E system has 2 modes for energy saving, which can be chosen to meet different electricity demands.

### Mode 1:

In auto energy-saving mode, the system will self-adjust parameters according to the operation status, thus to lower the cost of electricity. Up to 15% of energy can be saved.

### Mode 2:

In compulsory energy-saving mode, the system will limit power output forcibly. Up to 20% of energy can be saved.

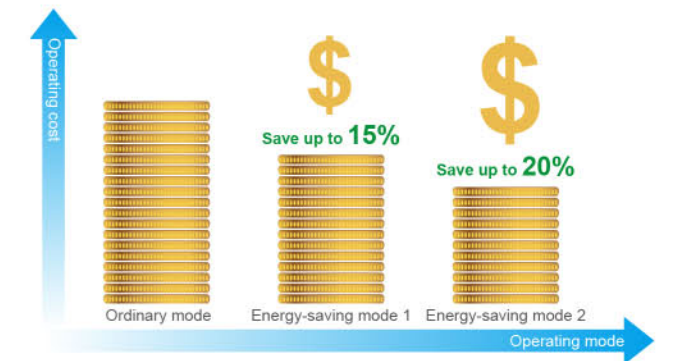

## Intelligent Defrosting Control

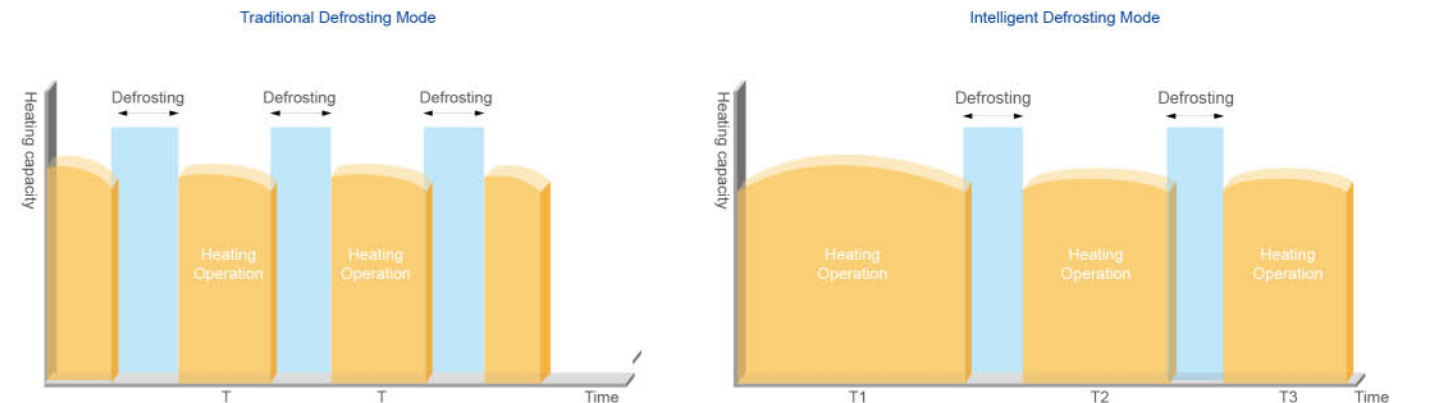

During the heating process, the frost status of the unit will be different after affecting by factors of outdoor ambient temperature, load status and operation time. Through real-time detection of operation parameters of the system, it can decide the defrosting time by intelligently estimating the thickness of frost, high pressure of system and blockage status of heat exchanger.



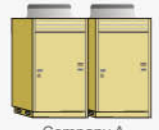

### Accurate Intelligent Allocation Technology of Capacity and Output of Optimal Portion to Ensure Highest Efficiency

- When total load demands more than 75% of a running system's capacity, one more unit will automatically start;
- When total load demands less than 40% of a running system's capacity, one unit will automatically shut down;
- Therefore, each unit shares 40%-75% of the total load.
- Experiments show that an air conditioner costs the least energy when it's operating within 40%-75% of its capacity.

	 Company A	 Gree GMV
Allocation Method	10HP(full load) + 2HP(low load)	6HP(partial load) + 6HP(partial load)
Performance Compared	Unit costs more energy and may be soon damaged.	Unit costs less energy and can always be kept in good condition.

### Output of Optimal Portion to Ensure Highest Efficiency

The best heating or cooling performance can be realized in the most energy-saving way. DC inverter compressor and DC inverter fan will also be operating in this way to ensure high efficiency.

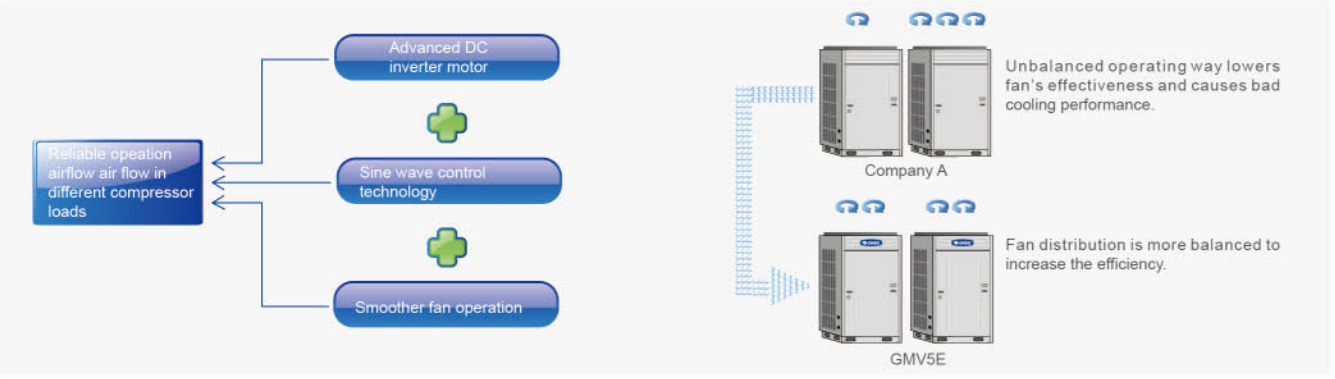

### Sub-cooling Control Technology to Ensure Optimal Cooling and Heating

- Heat exchange loop can control the first subcooling process of heat exchanger. Subcooling degree can reach 11°C.
- Subcooling loop can realize 9°C second subcooling to guarantee cooling and heating performance.

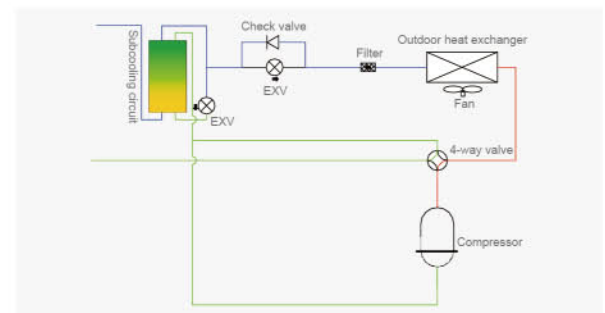
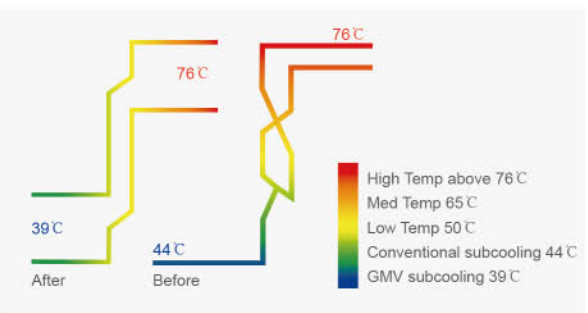

### Temperature Controlled by Wired Controller with Higher Efficiency and More Energy Saving

Through setting temperature lower limit in cooling or dry mode, and setting temperature upper limit in heating, 3D heating or heat supply mode, the system is able to operate in a smaller temperature range so as to achieve energy saving.

### Comfortable Design for A Better Life

The GMV5E system has a wide range of working conditions. Whether it's in a cool winter or a hot summer, normal operation is guaranteed with the least noise, making users feel more comfortable.

### Outdoor Unit Quiet Mode and Quiet Control

- **Quiet at night**  
The system can record the highest outdoor temperature. At night, the system will automatically turn to quiet mode. There are 9 quiet modes which can be set according to actual needs.

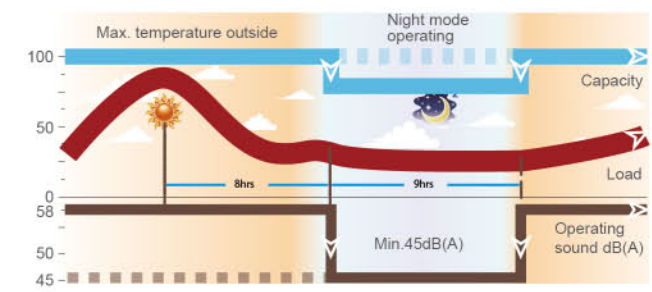

### Quiet in compulsion

The system can also be set in this mode to ensure low noise as long as it is operating. Noise is as low as 45dB(A).

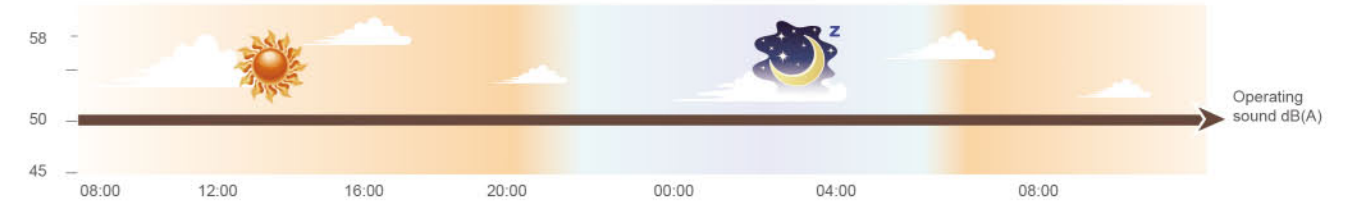

### Quiet Control

1. **Optimized Bossing Design**  
After many times of CFD tests, a new fan bossing structure has been developed to reduce vibration of fan during running. Noise can be reduced by 3dB(A).

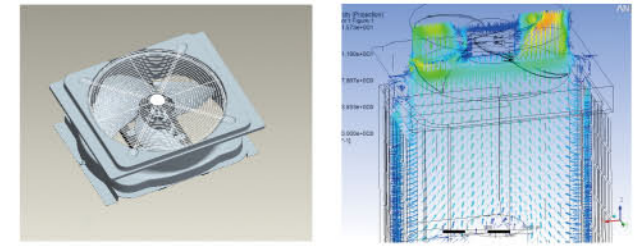

2. **Aerodynamics 3D Axial Fan**  
Compared with conventional fan, it can increase air volume by 12%, improving efficiency as well as lowering noise.





### Quiet Indoor Unit

The indoor unit of the GMV5E system also adopts DC inverter motors to realize stepless regulation. According to indoor temperature or people's needs, users can set this mode through wired controller. Noise is as low as 22dB(A).

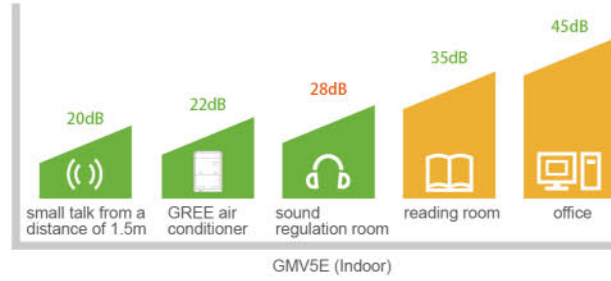

### Fast Start-up in Heating

DC Compressor is first started to avoid too much electric current. Inverter compressor can operate in high frequency once starts up, so as to produce more heat.

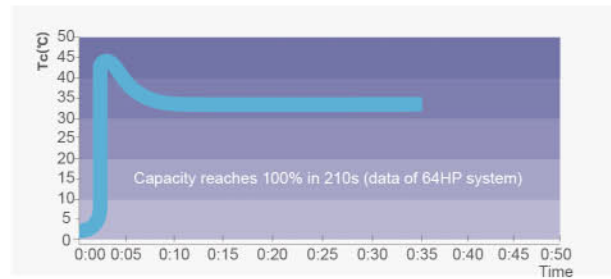

### 7 Speeds Indoor Fan

Indoor fan speed can be set in 7 levels by wired controller. They are auto, low speed, medium-low speed, medium speed, medium-high speed, high speed and turbo. When the wired controller is on, press "FAN" button to set indoor fan speed circularly as below:

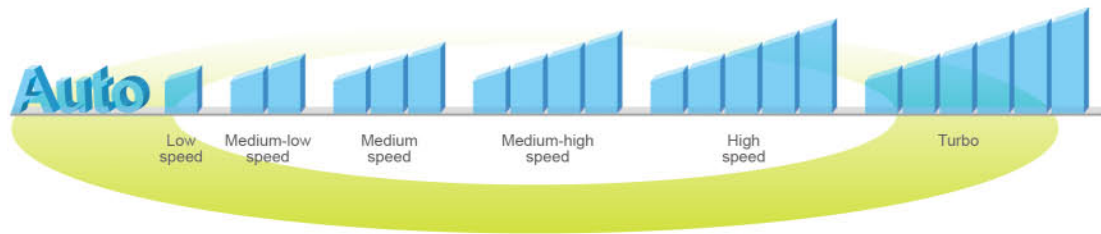

## Excellent Performance Ensured by Advanced Technology

### Two-stage Oil Separation Control Technology (Patented)

First-stage oil separator adopts a filtration expansion valve with separation efficiency of 98%; Second-stage oil separator will separate the remained 2% refrigerant oil with separation efficiency of 95%. General oil separation efficiency reaches 99.9%.

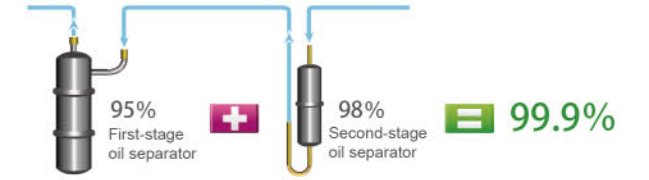

### Oil Return Control Technology

#### New Oil Return Control

Gree new oil return control technology effectively controls system oil return and oil storage status of each compressor, which greatly improves the operation lifespan of compressor.

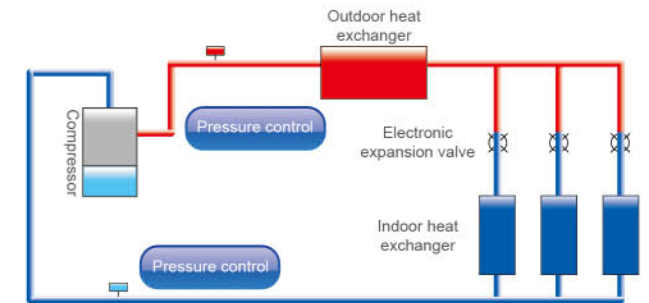
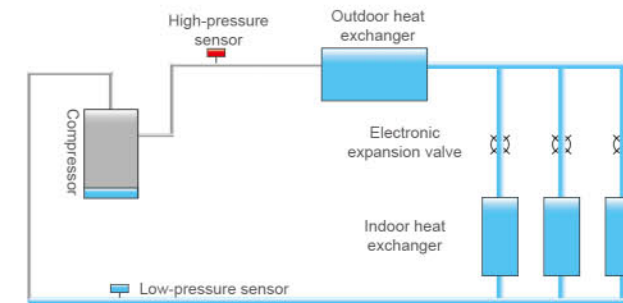

#### Specialized Compressor Oil Storage Control

The system applies specialized compressor oil storage technology, which can control the lowest oil level for compressor operation.

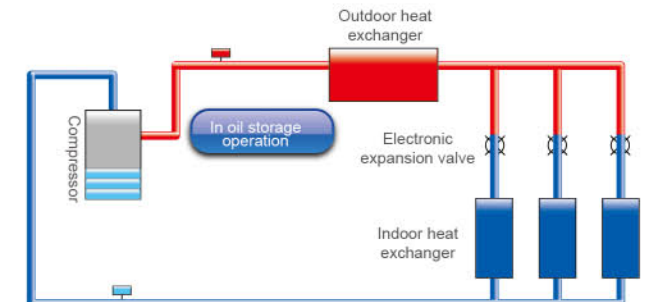



### Oil Balance Control Technology

**Oil Balance between Each Module**  
Based on the actual status of each module and compressor, the system can regulate compressor's operation and realize oil balance of each module.

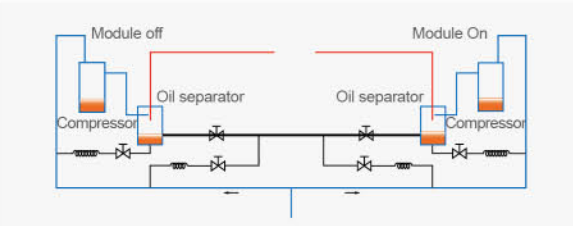

**Oil Balance between Each Compressor**  
Refrigerant is taken into the compressor by the suction pipe and then runs through the cooling system. It can control the oil level and minimum oil volume required by each compressor so as to realize oil balance between each compressor.

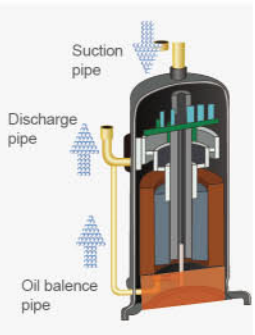

### Intelligent Detection Control

**Pressure Sensor Detection Control**  
Pressure sensor can precisely detect system high pressure and low pressure, and adjust output of fan and compressor, so as to make sure the system can work under the most energy-saving pressure condition.

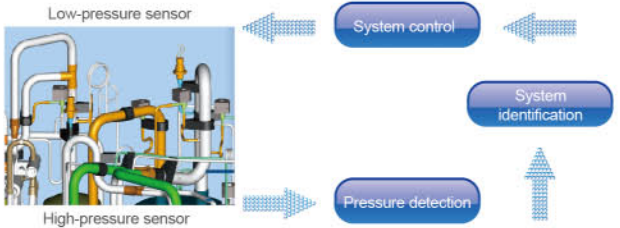

**Temperature Sensor Detection Control**  
Various temperature sensors are equipped to detect ambient temperature, indoor temperature and refrigerant's evaporating temperature, from which the operation status can be measured.

### Multi Electronic Expansion Valves Control

Outdoor electronic expansion valve not only has throttling effect, but also control refrigerant flow. The system adopts multi electronic expansion valves control with total 960 grades regulated by two electronic expansion valves, so as to regulate refrigerant flow precisely and ensures reliable operation of system.

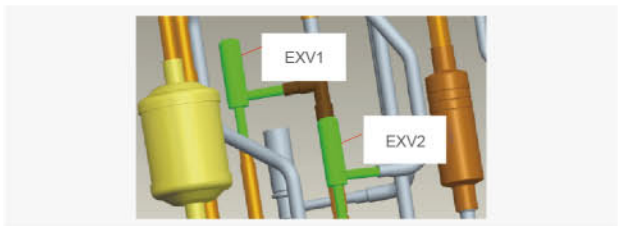

### Smaller Impact to Power Grid

The start-up frequency of inverter compressor is gradually increased from 0Hz to the appointed operation frequency. The start-up current of compressor rotor is decreased by reducing load torque, hence impact to power grid during start-up is reduced and electromagnetic impact to compressor is reduced too.

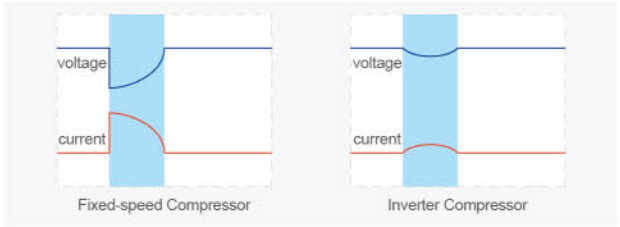

### Modules Rotation Operating to Maximize Lifespan

**Modules 8h rotation operating**  
The operating priority sequence of the outdoor unit modules will be changed without restart when the system accumulatively operates for 8 hours, which can maximize the service life of the system.



### Highly Anticorrosive Golden Fins

The primary material of Golden Fin is Al-Mn(Aluminum-Manganese) anti-rust alloy, which is coated with the Golden Protection Layer(Components: Exoxy Resin & Modified Acrylic, Silicon free), the anti-corrosive performance in salt-spray testing is 200%~300% higher than normal Blue Fin\*.

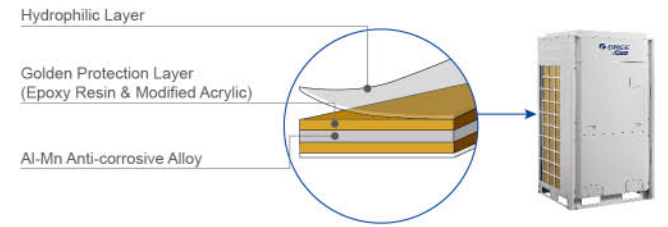

Note: Salt-spray testing result is from GREE materials chemistry testing laboratory.

### Emergency Auto-Off Control

The outdoor unit can be linked with a fire alarm signal. In case of emergency, unit can automatically turn off to avoid risk or further loss.

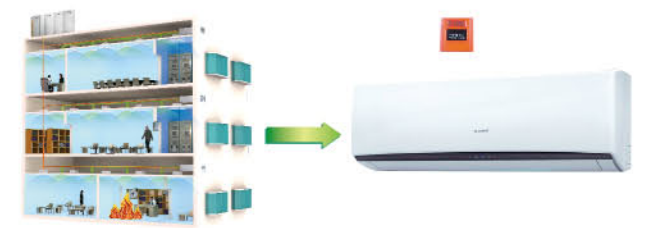

### Lower Power Consumption Operation Mode

As for the area with power consumption limited time period, the maximum power consumption can be set for the operation. Basing on the power consumption of unit and user's requirement, power consumption limitation can be set according to 100%, 90% or 80% of the capacity of complete unit. In this case, user can have more selection at the power consumption limited time period.





### Electricity Shortage Identification

The outdoor unit can receive a power signal of electricity shortage. In some places like first-class hotels, if diesel generator is used temporarily for providing electricity, outdoor unit will send the electricity shortage signal to indoor unit. In this case, only VIP rooms can be provided with air conditioning service.

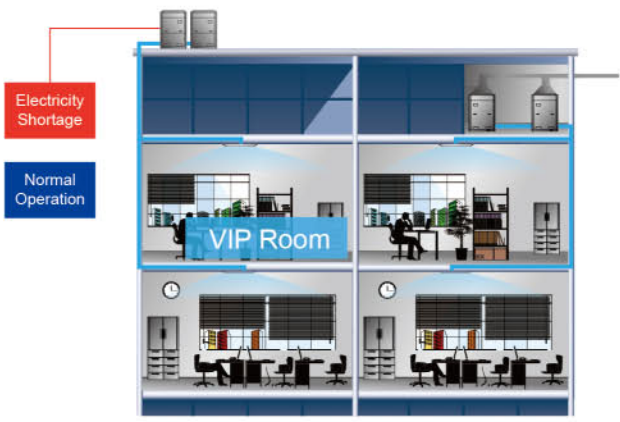

### Excellent Emergency Operation Function to Ensure Reliable Operation

#### Emergency Function

The GMV5E system can realize a combination of 4 outdoor unit modules. When error is occurred to one of the modules, the others will perform the emergency operation to sustain the air conditioning.



#### Emergency Operation of Compressor

All the compressors in each single module are DC Inverter based, when one compressor has error, others will perform the emergency operation.

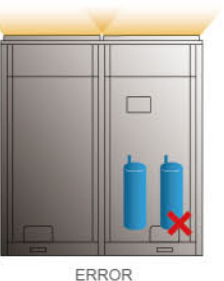

#### Emergency Operation of Fan

Double-fan design fan ensures that one fan can still work even if the other one has error.

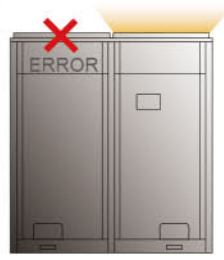

### SRL (Self-reaction Load) Self-adaptive Control

SRL (Self-reaction Load) can intelligently detect and control system parameters and automatically adapt to indoor cold/heat load requirement to reducing unit's power and improve the energy efficiency.

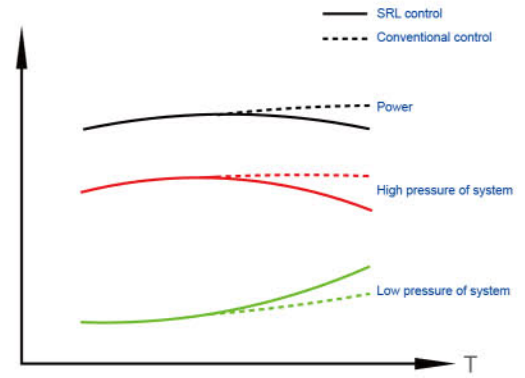

### ODU High Static Pressure Design

System has 4 levels of static pressure that can be set. Up to 82Pa pressure can be set for an outdoor unit. This design is especially useful when an outdoor unit needs to be placed indoor.



### 1000m Pipe Design for Flexible Installation

GMV5E system can be applied in different types of building construction. One of its advantages is the simple pipe design, which will simplify the installation and reduce installation cost.

- Max total pipe length reaches 1000m (with limitation)
- Actual pipe length between the outdoor unit and the farthest indoor unit: 165m
- Max height difference between indoor unit and outdoor unit: 90m

Note:  
a: Distance between the first branch and the farthest indoor unit.  
b: Distance between the first branch and the nearest indoor unit.  
a-b≤40m

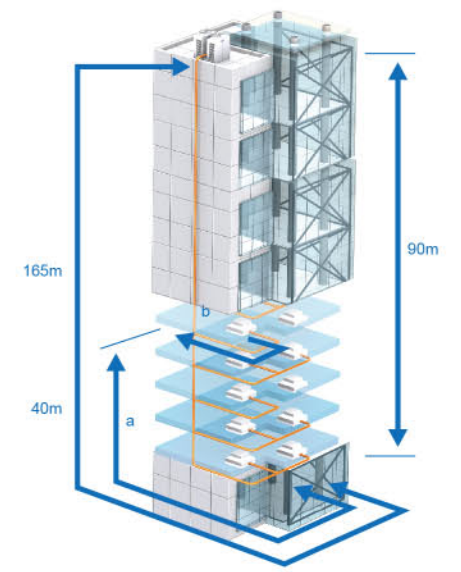

### Engineering Debugging for Convenient Construction

#### 1) GMV5E has five auto debugging features:

- Automatic allocation of IDU and ODU addresses
- Automatic detection of IDU and ODU quantity
- Automatic detection of errors
- Automatic start-up of debugging
- Real-time judgment of pipe errors

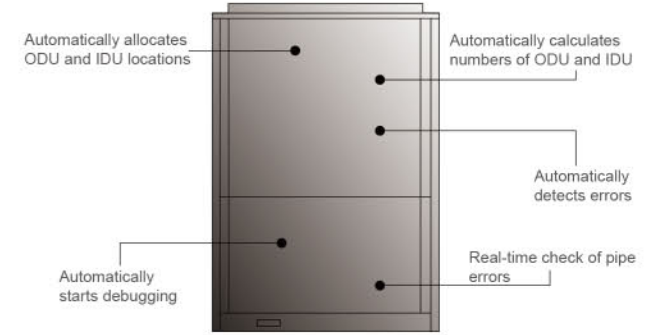

#### 2) Diversified debugging methods for satisfying different requirements and improving debugging efficiency:

- ① Button debugging of outdoor unit
- ② Special GMV debugging system
- ③ CE41-24/F(C) debugger\* has functions of debugging of complete unit, independent debugging of indoor unit, malfunction display, data record and so on. It's no need to connect special software and PC. Moreover, it can connect external USB storage data.



①

Note:\* This debugger is under development.

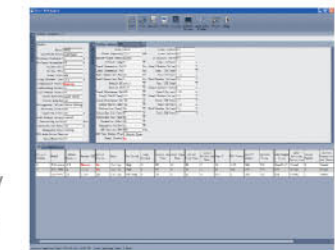

②



③



### Auto-refrigerant Recovery for Easy Maintenance

When auto refrigerant recovery function is set and cut-off valve of liquid pipe is closed during maintenance, the system will automatically operate compressor, EXV, solenoid valve and fan, etc. Taking advantage of compressor power, the refrigerant is recovered at the condensing side of outdoor unit to achieve environmental effect. Meanwhile, system low pressure is displayed simultaneously during refrigerant recovery.

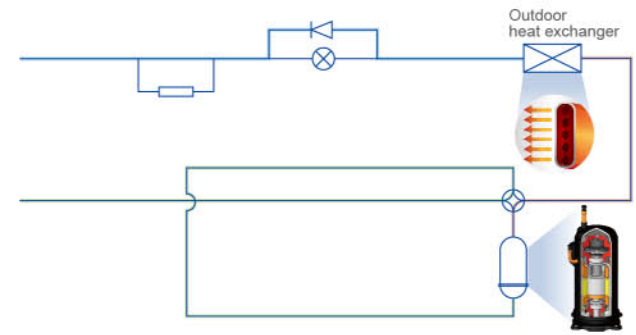

### Inspection Window for Convenient Checking

Inspection window is available for quick checking of system operation status. No need to open panel for checking, which will be more time-saving and easier for maintenance.

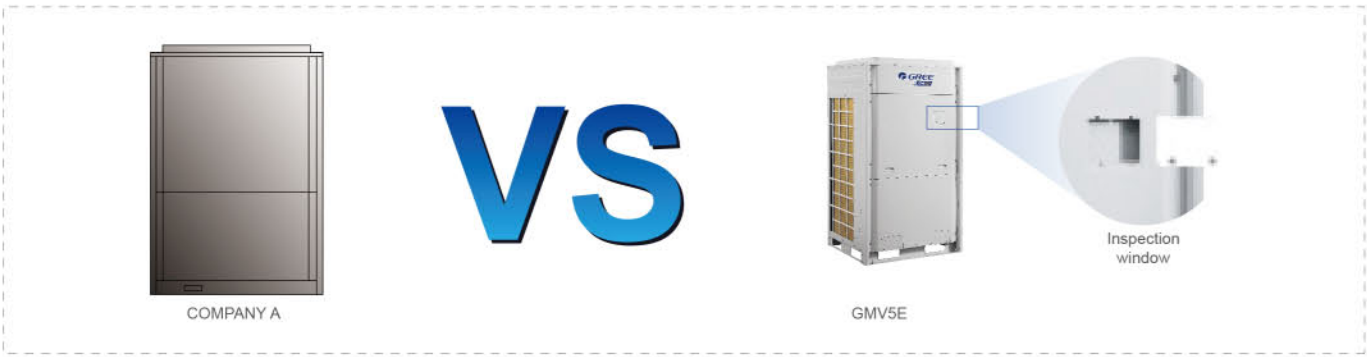

### Flexible Wiring

Common wire can meet the communication demand with no need of specialized communication wire. Common sheath twisted pair cable can be used as there is no polarity requirement.

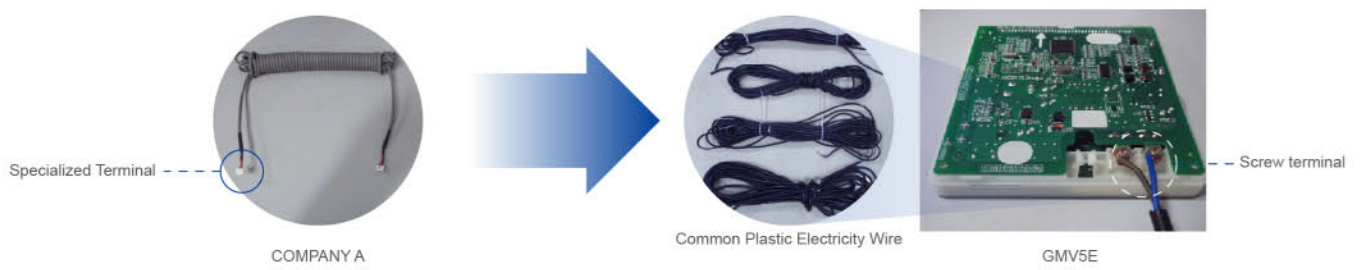

### Auto Addressing of Outdoor and Indoor Unit

CAN network is adopted to achieve auto addressing of outdoor and indoor unit. It can allocate IDU and ODU addresses and detect IDU and ODU quantity, which greatly improves construction efficiency.



## Professional Hotel Functions

Gree GMV5E provides hotels with unique season setting function and key-card control function.

### Season Setting

Cooling or heating mode can be deactivated during a certain season to avoid affecting unit's normal operation due to mode conflict.

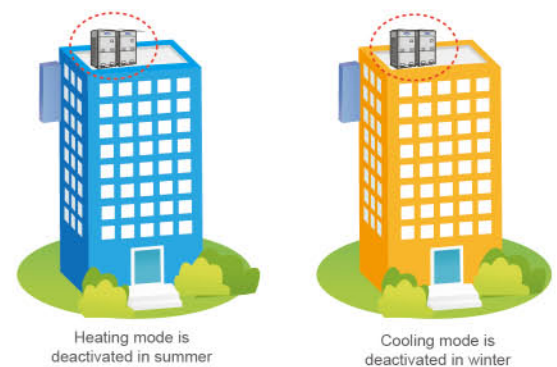

### Key-card Control for Hotel Management

The unit can be turned on or off by inserting or removing the key-card. When the key-card is removed, the system can remember all the setting and stop operation. When the key-card is inserted back, the system will be under standby mode or operate according to the status before removing key-card. It is well suited to hotels, restaurants, etc.





Combination of GMV5E\*

Model	GMV-224WME-X	GMV-280WME-X (GMV-280WME1-X)	GMV-335WME-X	GMV-400WME-X	GMV-450WME-X (GMV-450WME1-X)	GMV-504WME-X	GMV-560WME-X	GMV-615WME-X
GMV-224WME-X	●							
GMV-280WME-X (GMV-280WME1-X)		●						
GMV-335WME-X			●					
GMV-400WME-X				●				
GMV-450WME-X (GMV-450WME1-X)					●			
GMV-504WME-X						●		
GMV-560WME-X							●	
GMV-615WME-X								●
GMV-680WME-X	●			●				
GMV-730WME-X	●				●			
GMV-785WME-X	●					●		
GMV-850WME-X	●						●	
GMV-900WME-X	●							●
GMV-960WME-X			●					●
GMV-1010WME-X				●				●
GMV-1065WME-X					●			●
GMV-1130WME-X						●		●
GMV-1180WME-X							●	●
GMV-1235WME-X								●●
GMV-1300WME-X	●				●		●	
GMV-1350WME-X	●				●			●
GMV-1410WME-X			●		●			●
GMV-1460WME-X	●						●	●
GMV-1515WME-X	●							●●
GMV-1580WME-X			●					●●
GMV-1630WME-X				●				●●
GMV-1685WME-X					●			●●
GMV-1750WME-X						●		●●
GMV-1800WME-X							●	●●
GMV-1845WME-X								●●●
GMV-1908WME-X	●				●		●	●
GMV-1962WME-X	●					●	●	●
GMV-2016WME-X	●						●●	●
GMV-2072WME-X	●						●	●●
GMV-2128WME-X	●							●●●
GMV-2184WME-X			●					●●●
GMV-2240WME-X				●				●●●
GMV-2295WME-X					●			●●●
GMV-2350WME-X						●		●●●
GMV-2405WME-X							●	●●●
GMV-2460WME-X								●●●●

Note:  
 1. Due to the same capacity, GMV-280WM/E1-X model and GMV-280WM/E-X model can replace each other for operation, GMV-450WM/E1-X model and GMV-450WM/E-X model can replace each other for operation.  
 2. The combination models of the outdoor units are not Eurovent certified.

GMV5E 50Hz&60Hz (380~415V)

Model			GMV-224WME-X	GMV-280WME-X	GMV-280WME1-X	GMV-335WME-X	GMV-400WME-X	
Capacity range		HP	8	10	10	12	14	
Capacity	Cooling	Nom.	kW	22.4	28	28	33.5	40
		Nom.	kW	25	31.5	31.5	37.5	45
		Max.	kW	25	31.5	31.5	37.5	45
EER		kW/kW	4.73	4.48	3.05	3.99	3.80	
COP	Heating	Nom.	kW/kW	5.20	5.56	4.10	5.25	4.73
		Max.	kW/kW	5.20	5.56	4.10	5.25	4.73
Power supply	V/Ph/Hz		380~415V 3Ph 50/60Hz					
Max. Circuit/Fuse Current	A		16.1/20	20.9/25	20.9/25	24.6/32	28.8/40	
Power consumption	Cooling	Nom.	kW	4.74	6.25	9.18	8.40	10.53
		Nom.	kW	4.81	5.67	7.68	7.14	9.51
		Max.	kW	4.81	5.67	7.68	7.14	9.51
Maximum drive IDU NO.	unit		13	16	16	19	23	
Refrigerant Charge volume	kg		5.9	9	6.7	8.2	9.8	
Sound power level	Cooling	Nom.	dB(A)	80	84	84	78	91
Sound pressure level	Cooling	Nom.	dB(A)	60	61	61	63	63
Connecting pipe	Liquid	mm	Φ9.52	Φ9.52	Φ9.52	Φ12.7	Φ12.7	
		Gas	mm	Φ19.05	Φ22.2	Φ22.2	Φ25.4	Φ25.4
		Oil balance	mm	Φ9.52	Φ9.52	Φ9.52	Φ9.52	Φ9.52
Dimension(WxDxH)	Outline	mm	930×765×1605	930×765×1605	930×765×1605	1340×765×1605	1340×765×1605	
	Package	mm	1010×840×1775	1010×840×1775	1010×840×1775	1420×840×1775	1420×840×1775	
Net weight/Gross weight	kg		225/235	235/245	225/235	285/300	360/375	
Loading quantity	40' GP	set	24	24	24	16	16	
	40' HQ	set	24	24	24	16	16	

Model			GMV-450WME-X	GMV-450WME1-X	GMV-504WME-X	GMV-560WME-X	GMV-615WME-X	
Capacity range		HP	16	16	18	20	22	
Capacity	Cooling	Nom.	kW	45	45	50.4	56	61.5
		Nom.	kW	50	50	50.4	56	61.5
		Max.	kW	50	50	56.5	63	69.0
EER		kW/kW	3.51	3.35	3.20	2.80	2.10	
COP	Heating	Nom.	kW/kW	4.60	4.20	4.10	3.90	3.70
		Max.	kW/kW	4.60	4.20	4.01	3.80	3.65
Power supply	V/Ph/Hz		380~415V 3Ph 50/60Hz					
Max. Circuit/Fuse Current	A		33.2/40	33.2/40	44.7/50	50/63	53.6/63	
Power consumption	Cooling	Nom.	kW	12.82	13.43	15.75	20.00	29.29
		Nom.	kW	10.86	11.90	12.29	14.36	16.62
		Max.	kW	10.86	11.90	14.10	16.60	18.90
Maximum drive IDU NO.	unit		26	26	29	33	36	
Refrigerant Charge volume	kg		10.3	10.3	11.3	14.3	14.3	
Sound power level	Cooling	Nom.	dB(A)	93	90	89	84	84
Sound pressure level	Cooling	Nom.	dB(A)	63	63	63	63	64
Connecting pipe	Liquid	mm	Φ12.7	Φ12.7	Φ15.9	Φ15.9	Φ15.9	
		Gas	mm	Φ28.6	Φ28.6	Φ28.6	Φ28.6	Φ28.6
		Oil balance	mm	Φ9.52	Φ9.52	Φ9.52	Φ9.52	Φ9.52
Dimension(WxDxH)	Outline	mm	1340×765×1740	1340×765×1605	1340×765×1740	1340×765×1740	1340×765×1740	
	Package	mm	1420×840×1910	1420×840×1775	1420×840×1910	1420×840×1910	1420×840×1910	
Net weight/Gross weight	kg		360/375	360/375	360/375	385/400	385/400	
Loading quantity	40' GP	set	16	16	16	16	16	
	40' HQ	set	16	16	16	16	16	



Specifications of GMV5E Combination

Model	Power Supply	Capacity			Power Input			Dimension(W×D×H) mm	Airflow Volume m <sup>3</sup> /h	ESP Pa	Connecting pipe diameter		Oil Balance Pipe mm	Mn. circuit current A	Max fuse current A	Weight kg
		Cooling		Heating	Cooling		Heating				Liquid mm	Gas mm				
		Nom.	Nom.	Max.	Nom.	Nom.	Max.									
		kW	kW	kW	kW	kW	kW									
GMV-680WME-X	380~415V 3Ph 50/60Hz	68.0	76.5	76.5	16.8	15.2	15.2	(930×765×1605) +(1340×765×1605)	11400+ 14000	82	Φ15.9	Φ28.6	Φ9.52	49.7	63	235+360
GMV-730WME-X		73.0	81.5	81.5	19.1	16.5	16.5	(930×765×1605) +(1340×765×1740)	11400+ 16000	82	Φ19.05	Φ31.8	Φ9.52	54.1	63	235+360
GMV-785WME-X		78.4	81.9	88.0	22.0	18.0	19.8	(930×765×1605) +(1340×765×1740)	11400+ 16000	82	Φ19.05	Φ31.8	Φ9.52	65.6	80	235+360
GMV-850WME-X		84.0	87.5	94.5	26.3	20.0	22.3	(930×765×1605) +(1340×765×1740)	11400+ 16000	82	Φ19.05	Φ31.8	Φ9.52	70.9	80	235+385
GMV-900WME-X		89.5	93.0	100.5	35.5	22.3	24.6	(930×765×1605) +(1340×765×1740)	11400+ 16000	82	Φ19.05	Φ31.8	Φ9.52	74.5	80	235+385
GMV-960WME-X		95.0	99.0	106.5	37.7	23.8	26.0	(1340×765×1605) +(1340×765×1740)	14000+ 16000	82	Φ19.05	Φ31.8	Φ9.52	78.2	80	285+385
GMV-1010WME-X		101.5	106.5	114.0	39.8	26.1	28.4	(1340×765×1605) +(1340×765×1740)	14000+ 16000	82	Φ19.05	Φ38.1	Φ9.52	82.4	100	360+385
GMV-1065WME-X		106.5	111.5	119.0	42.1	27.5	29.8	(1340×765×1740) ×2	16000×2	82	Φ19.05	Φ38.1	Φ9.52	86.8	100	360+385
GMV-1130WME-X		111.9	111.9	125.5	45.0	28.9	33.0	(1340×765×1740) ×2	16000×2	82	Φ19.05	Φ38.1	Φ9.52	98.3	125	360+385
GMV-1180WME-X		117.5	117.5	132.0	49.3	31.0	35.5	(1340×765×1740) ×2	16000×2	82	Φ19.05	Φ38.1	Φ9.52	103.6	125	385×2
GMV-1235WME-X		123.0	123.0	138.0	58.6	33.2	37.8	(1340×765×1740) ×2	16000×2	82	Φ19.05	Φ38.1	Φ9.52	107.2	125	385×2
GMV-1300WME-X		129.0	137.5	144.5	39.1	30.9	33.1	(930×765×1605) +(1340×765×1740) ×2	11400+1 6000×2	82	Φ19.05	Φ38.1	Φ9.52	104.1	125	235+360 +385
GMV-1350WME-X		134.5	143.0	150.5	48.4	33.2	35.4	(930×765×1605) +(1340×765×1740) ×2	11400+ 16000×2	82	Φ19.05	Φ38.1	Φ9.52	107.7	125	235+360 +385
GMV-1410WME-X		140.0	149.0	156.5	50.5	34.6	36.9	(1340×765×1605) +(1340×765×1740) ×2	14000+ 16000×2	82	Φ19.05	Φ41.3	Φ9.52	111.4	125	285+360 +385
GMV-1460WME-X		145.5	149.0	163.5	55.5	36.7	41.2	(930×765×1605) +(1340×765×1740) ×2	11400+ 16000×2	82	Φ19.05	Φ41.3	Φ9.52	124.5	160	235+385 ×2
GMV-1515WME-X		151.0	154.5	169.5	64.8	38.9	43.5	(930×765×1605) +(1340×765×1740) ×2	11400+ 16000×2	82	Φ19.05	Φ41.3	Φ9.52	128.1	160	235+385 ×2
GMV-1580WME-X		156.5	160.5	175.5	67.0	40.4	44.9	(1340×765×1605) +(1340×765×1740) ×2	14000+ 16000×2	82	Φ19.05	Φ41.3	Φ9.52	131.8	160	285+385 ×2
GMV-1630WME-X		163.0	168.0	183.0	69.1	42.8	47.3	(1340×765×1605) +(1340×765×1740) ×2	14000+ 16000×2	82	Φ19.05	Φ41.3	Φ9.52	136.0	160	360+385 ×2
GMV-1685WME-X		168.0	173.0	188.0	71.4	44.1	48.7	(1340×765×1740) ×3	16000×3	82	Φ19.05	Φ41.3	Φ9.52	140.4	160	360+385 ×2
GMV-1750WME-X		173.4	173.4	194.5	74.3	45.5	51.9	(1340×765×1740) ×3	16000×3	82	Φ19.05	Φ41.3	Φ9.52	151.9	160	360+385 ×2
GMV-1800WME-X		179.0	179.0	201.0	78.6	47.6	54.4	(1340×765×1740) ×3	16000×3	82	Φ19.05	Φ41.3	Φ9.52	157.2	180	385×3
GMV-1845WME-X		184.5	184.5	207.0	87.9	49.9	56.7	(1340×765×1740) ×3	16000×3	82	Φ19.05	Φ41.3	Φ9.52	160.8	180	385×3
GMV-1908WME-X		190.5	199.0	213.5	68.4	47.5	52.0	(930×765×1605) +(1340×765×1740) ×3	11400+ 16000×3	82	Φ22.2	Φ44.5	Φ9.52	157.7	180	235+360 +385×2
GMV-1962WME-X		195.9	199.4	220.0	71.3	48.9	55.3	(930×765×1605) +(1340×765×1740) ×3	11400+ 16000×3	82	Φ22.2	Φ44.5	Φ9.52	169.2	180	235+360 +385×2
GMV-2016WME-X		201.5	205.0	226.5	75.5	51.0	57.8	(930×765×1605) +(1340×765×1740) ×3	11400+ 16000×3	82	Φ22.2	Φ44.5	Φ9.52	174.5	200	235+385 ×3
GMV-2072WME-X		207.0	210.5	232.5	84.8	53.3	60.1	(930×765×1605) +(1340×765×1740) ×3	11400+ 16000×3	82	Φ22.2	Φ44.5	Φ9.52	178.1	200	235+385 ×3
GMV-2128WME-X		212.5	216.0	238.5	94.1	55.5	62.4	(930×765×1605) +(1340×765×1740) ×3	11400+ 16000×3	82	Φ22.2	Φ44.5	Φ9.52	181.7	200	235+385 ×3
GMV-2184WME-X		218.0	222.0	244.5	96.3	57.0	63.8	(1340×765×1605) +(1340×765×1740) ×3	14000+ 16000×3	82	Φ22.2	Φ44.5	Φ9.52	185.4	200	285+385 ×3
GMV-2240WME-X		224.5	229.5	252.0	98.4	59.4	66.2	(1340×765×1605) +(1340×765×1740) ×3	14000+ 16000×3	82	Φ22.2	Φ44.5	Φ9.52	189.6	200	360+385 ×3
GMV-2295WME-X		229.5	234.5	257.0	100.7	60.7	67.6	(1340×765×1740) ×4	16000×4	82	Φ22.2	Φ44.5	Φ9.52	194.0	225	360+385 ×3
GMV-2350WME-X		234.9	234.9	263.5	103.6	62.2	70.8	(1340×765×1740) ×4	16000×4	82	Φ22.2	Φ44.5	Φ9.52	205.5	225	360+385 ×3
GMV-2405WME-X		240.5	240.5	270.0	107.9	64.2	73.3	(1340×765×1740) ×4	16000×4	82	Φ22.2	Φ44.5	Φ9.52	210.8	225	385×4
GMV-2460WME-X	246.0	246.0	276.0	117.2	66.5	75.6	(1340×765×1740) ×4	16000×4	82	Φ22.2	Φ44.5	Φ9.52	214.4	225	385×4	

Note:  
 1. Due to the same capacity, GMV-280WM/E1-X model and GMV-280WM/E-X model can replace each other for operation, GMV-450WM/E1-X model and GMV-450WM/E-X model can replace each other for operation.  
 2. The combination models of the outdoor units are not Eurovent certified.

# GMV5 Mini & Slim





# Key Features

## All DC Inverter Technology to Improve Compression Efficiency

All DC inverter compressor and high-performance high pressure chamber are adopted to reduce loss of overheat and improve compression efficiency from direct intake. Compared with low pressure chamber, the compression efficiency is improved. High-efficient permasyn motor is adopted to provide better performance than traditional DC inverter compressor.

### All DC Inverter Compressor

- All DC inverter compressor is used in this system. It can directly intake gas to reduce loss of overheat and improve efficiency.

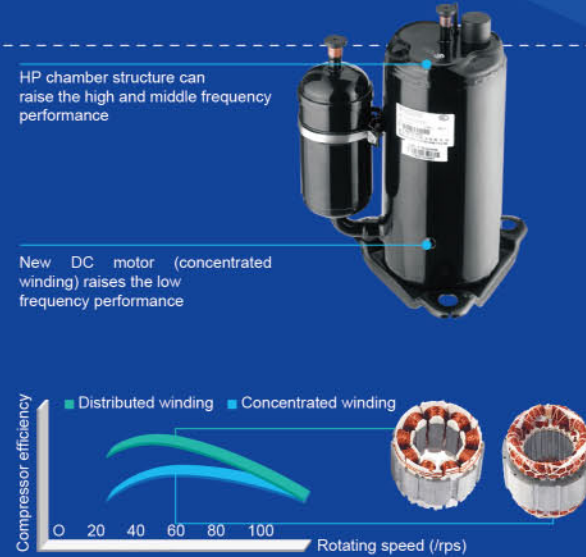

- High-efficient permasyn motor is adopted to provide better performance than traditional DC inverter compressor.

### Technology of Maximum Torque TControl with Minimum Current

It can reduce energy loss caused by device winding so as to realize higher efficiency.

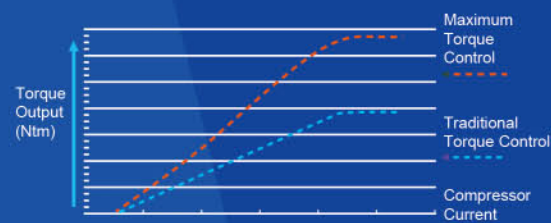

### 180° Sine Wave DC Speed Varying Technology

It can satisfy various places' demands for different temperature and is able to save a great deal of electricity and provide users with utmost comfort at the same time.

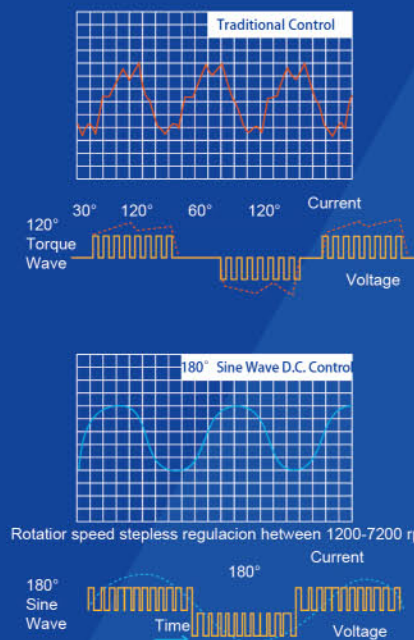

### Low-frequency Torque Control

It can directly control motor torque, through which fan motor can run at a low speed. Users will feel more comfortable while requirements of the system are also met.



## Sensorless DC Inverter Fan Motor

- Stepless speed regulation ranges from **5Hz** to **44Hz**. Compared with traditional inverter motors, the operation is more energy-saving.

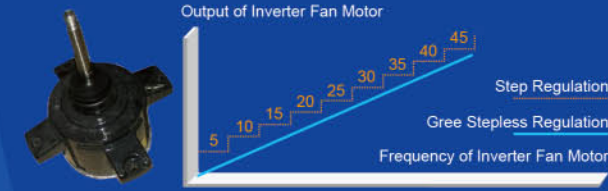

- Sensorless control technology guarantees lower noise, less vibration and steadier operation.

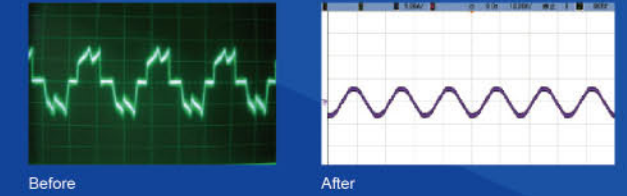

## Sensorless DC Inverter Fan Motor

The indoor unit adopts high-efficiency brushless DC motor. Compared with conventional motor, the efficiency of brushless DC motor is improved by more than **30%**. Meanwhile, the design of evaporation capacity flow is optimized through emulation software of refrigeration system and the heat exchange amount of evaporator is greatly improved.

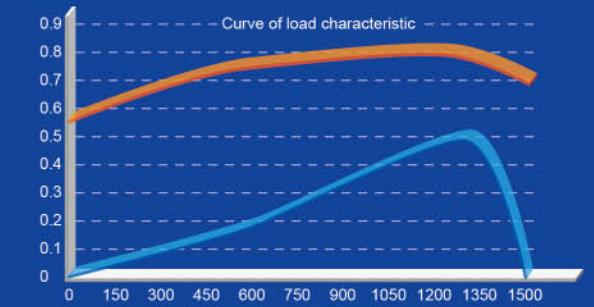

## High-efficiency Digital PFC Control \*

High-efficiency PFC control technology is adopted with efficiency improved by about 1% compared with conventional PFC. For the air conditioner with rated power of 5kW, **50W** of electricity can be saved every hour and **1.2kW** of electricity can be saved every day.

\*This feature is applicable for GMV5 Mini only.

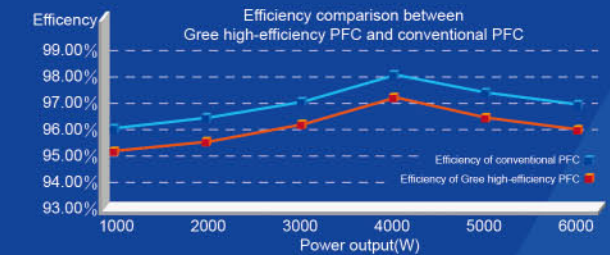

## Wider Operation Condition Range

The unit adopts DC motor with more accurate high pressure control, which effectively solves the high pressure control problem in low ambient temperature cooling. So the operation range in cooling is wider.

Company A	Gree GMV5 Mini	Gree GMV5 Slim
Cooling: 10~48°C Heating: -20~27°C	Cooling: -5~52°C Heating: -20~27°C	Cooling: -5~52°C Heating: -20~27°C



## Comfortable and Quiet Mode

### Low Noise of Outdoor Unit

- The advanced sub-cooling control technology is applied to reduce the liquid flow noise of indoor unit in cooling operation.
- Noise of outdoor unit can be as low as 45dB thanks to noise optimized design of fan system and compressor system, and multiple kinds of quiet modes of outdoor unit.



### Low Noise of Indoor Unit

- The pioneering and patented high-efficiency centrifugal fan blade and low-noise volute are adopted. Meanwhile, the imported silent valve is adopted to reduce noise of entire unit as low as 22db(A).
- By adopting the optimal inlet angle of centrifugal fan blade and optimal diameter ratio between internal and external circles of impeller, the air volume is increased and fan noise is decreased greatly.
- The advanced supercooling control technology and the oil-return technology under heating mode has efficiently solved the problem of liquid flow noise of indoor unit, which improved the sound quality of indoor unit.

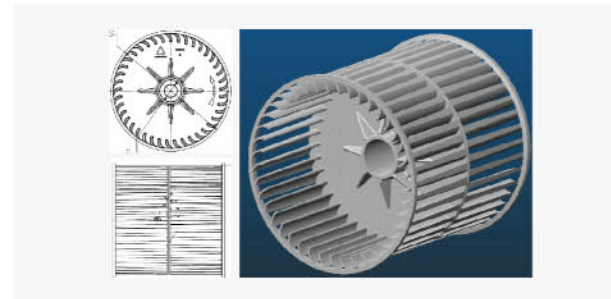
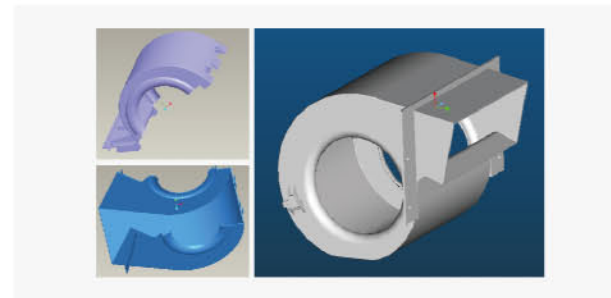

### Comfortable Heating

Advanced intelligent defrosting mode is adopted. Gree advanced intelligent defrosting mode will choose the best defrosting way according to outdoor temperature and operation status to realize intelligent defrosting, effectively improving heating effect and performance. While in traditional defrosting mode, timing defrosting is adopted, which not only affects comfort but also reduces energy efficiency.

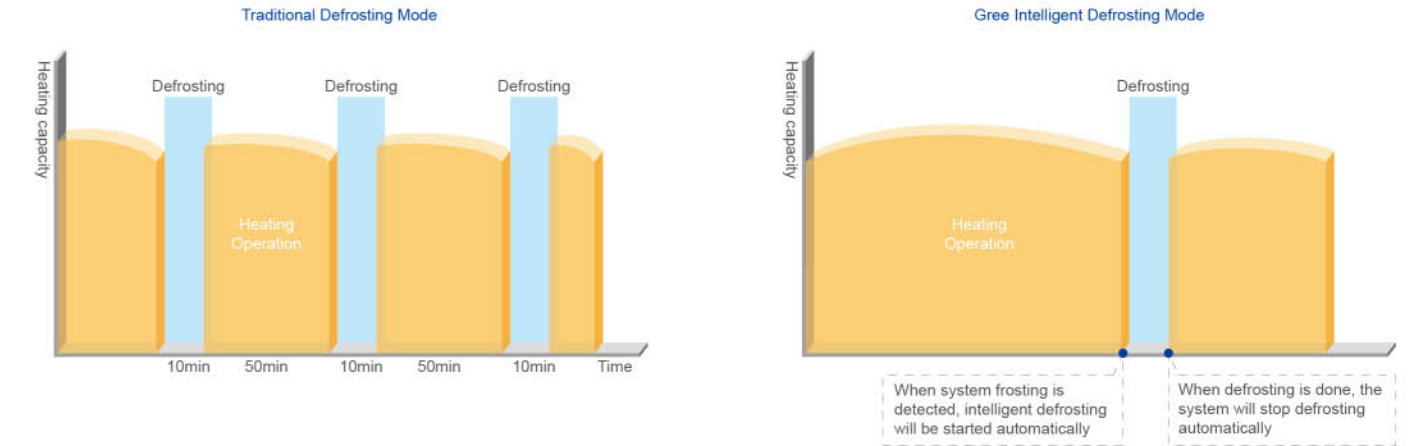

### Non-commutative Oil Return Technology in Heating

The unit can achieve non-commutative oil return in heating when outdoor ambient temperature is within 0~20°C. Thanks to this technology, indoor ambient temperature is more stable and comfort is improved in heating mode.

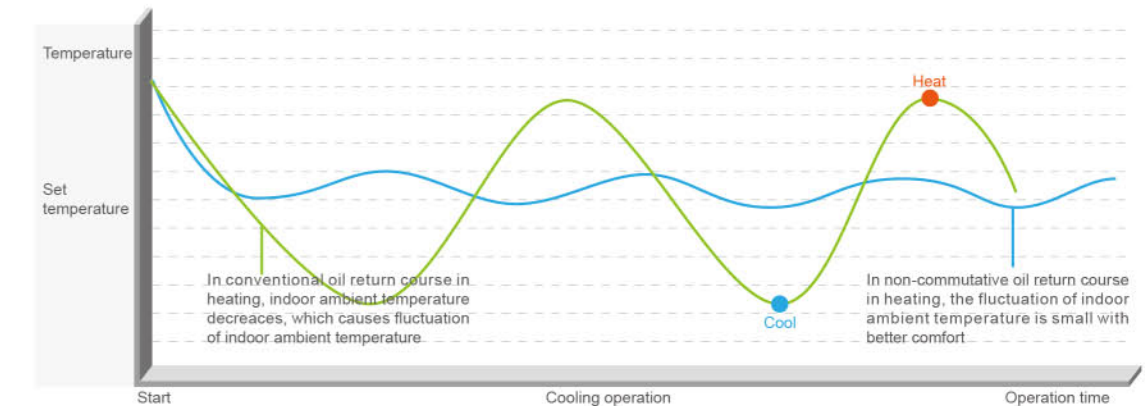

### Intelligent Temperature Control Technology

Intelligent temperature control technology is adopted for super fast cooling or heating, so that indoor temperature will reach set temperature more quickly.





## Reliable Operation

### Compressor Closed-loop Startup Technology with More Reliable Startup

The self-innovative closed-loop startup control technology is adopted. Thanks to this technology, the startup current is small and startup is more reliable.

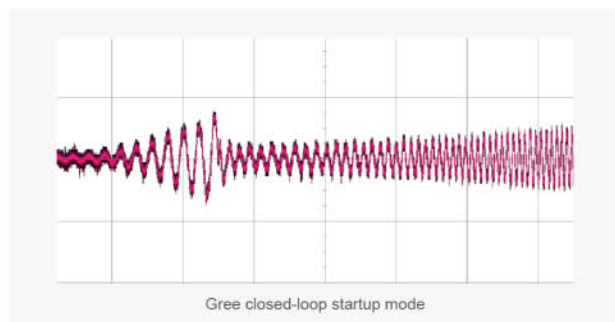
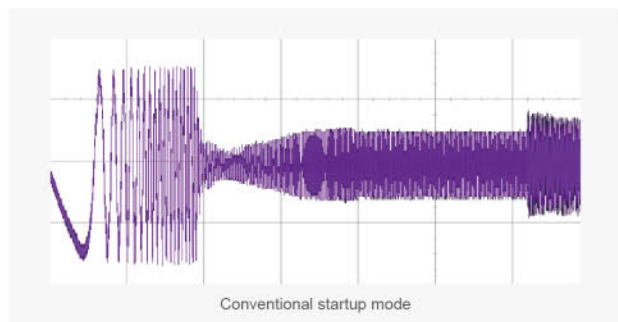

### High Anti-interference Ability

The latest CAN bus communication technology is adopted, with non-polar communication and high anti-interference ability. Common communication wire can meet the communication demand with no need of specialized shielded wire. The customers can buy the communication wire by themselves, greatly reducing installation difficulties.



### Advanced High-frequency Transformer with More Stable Voltage

- The advanced switching power supply is adopted with lower power consumption and higher power efficiency.
- Wide voltage-regulation range ensures stable voltage output when the voltage of grid fluctuates.
- Compared with conventional transformer, the size of high-frequency transformer is small and the weight is light.

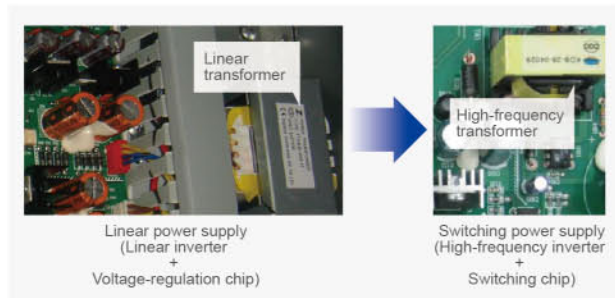

### Refrigerant Cooling Technology\*

- Usually, air-cooled fins are adopted for heat radiation. Due to large size and passive radiation, heat radiating effect is unsatisfactory; with refrigerant cooling technology, heat radiating effect is much better because of compact structure and active radiation. Module temperature is dropped from 80°C to 65 °C, which will increase module life and stability.

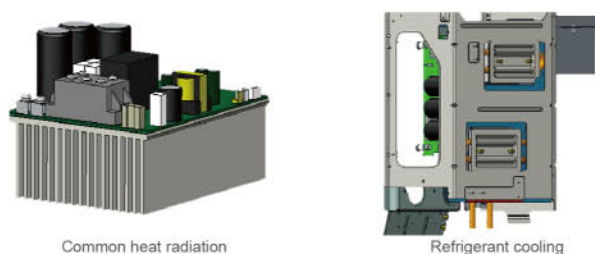

\*: This feature is applicable for GMV5 slim only.

## Easy Installation and Transportation

### Ultra-long Connection Pipe for More Convenient Connection

Under the subcooling control technology gained by adding subcooler, the indoor unit and outdoor unit of GMV5 mini can operate reliably with longer connection pipe.

	Company A	Gree GMV5 Slim	Gree GMV5 Mini	Gree GMV5 Mini
Total piping length	150m	300m	300m	250m
Equivalent piping length	70m	150m	150m	120m

### Top Advanced Light and Compact Size

GMV5 slim adopts small and compact size design. The dimension of the unit is 1430(H)×940(W) ×320(D). Compared with the normal product with the same capacity, size and weight are reduced a lot.

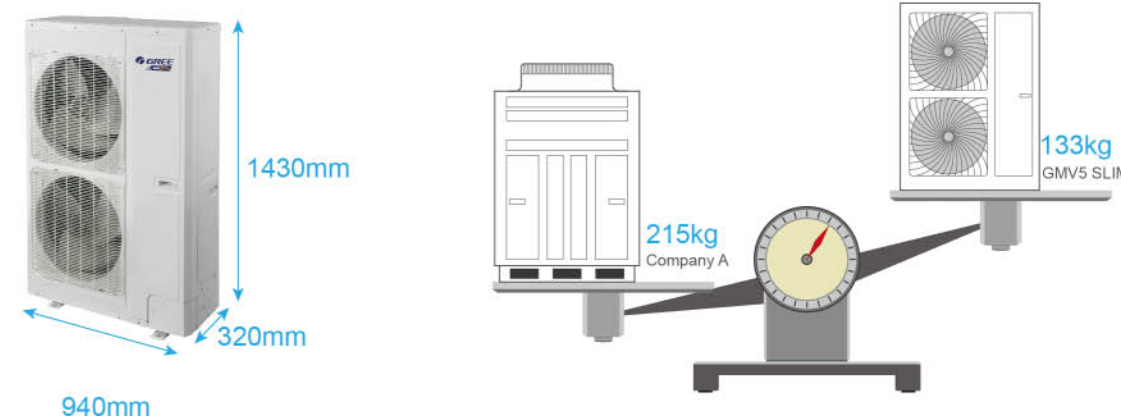

### Easy Installation with Lower Construction Cost

The outdoor unit of GMV5 slim is with small size and light weight. No need fork lifter and crane for movement and installation



### Movement by Stairs and Elevator

The outdoor unit of GMV5 slim is with compact and small size for saving space and easy movement. It can be carried by elevator or stairs.

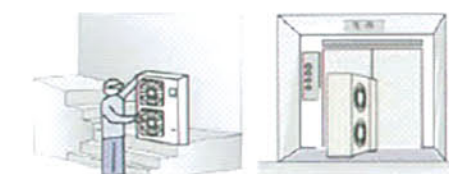



## Outdoor Units Lineup

### GMV5 Mini

HP	Model	Product
3	GMV-80WL/C-T	
3.5	GMV-100WL/C-T	
4	GMV-121WL/C-T	

### GMV5 Mini

HP	Model	Product
4	GMV-120WL/C-T GMV-120WL/C-X	
5	GMV-140WL/C-T GMV-140WL/C-X	
6	GMV-160WL/C-T GMV-160WL/C-X	

### GMV5 Slim

HP	Model	Product
8	GMV-224WL/C-X	
10	GMV-280WL/C-X	
12	GMV-335WL/C-X	

## GMV5 Mini

### 50Hz&60Hz (220~240V & 208~230V)

Model			GMV-80WL/C-T	GMV-100WL/C-T	GMV-121WL/C-T
Capacity range		HP	3	3.5	4
Capacity	Cooling	kW	8	10	12.1
	Heating	kW	9	11	13
EER		W/W	3.90	3.70	3.51
COP		W/W	4.74	4.40	4.81
Power supply		V/Ph/Hz	220-240/1/50 & 208-230/1/60		
Max. Circuit/Fuse Current		A	25	25	32
Power consumption	Cooling	kW	2.05	2.7	3.45
	Heating	kW	1.9	2.5	2.7
Maximum drive IDU NO.		unit	4	5	6
Refrigerant Charge volume		kg	1.8	1.8	2
Sound power level		dB(A)	68	69	70
Connecting pipe	Liquid	mm	Φ9.52	Φ9.52	Φ9.52
	Gas	mm	Φ15.9	Φ15.9	Φ15.9
Dimension(WxDxH)	Outline	mm	980×360×790	980×360×790	980×360×790
	Package	mm	1129×478×937	1129×478×937	1129×478×937
Net weight/Gross weight		kg	80/90	80/90	85/95
Loading quantity	40' GP	set	100	100	100
	40' HQ	set	100	100	100

Model			GMV-120WL/C-T	GMV-140WL/C-T	GMV-160WL/C-T
Capacity range		HP	4	5	6
Capacity	Cooling	kW	12.1	14	16
	Heating	kW	14	16.5	18
EER		W/W	3.99	3.90	3.37
COP		W/W	4.28	4.18	3.87
Power supply		V/Ph/Hz	220-240/1/50 & 208-230/1/60		
Max. Circuit/Fuse Current		A	32	40	40
Power consumption	Cooling	kW	3.03	3.59	4.75
	Heating	kW	3.27	3.95	4.65
Maximum drive IDU NO.		unit	7	8	9
Refrigerant Charge volume		kg	3.3	3.3	3.3
Sound power level		dB(A)	68	69	69
Connecting pipe	Liquid	mm	Φ9.52	Φ9.52	Φ9.52
	Gas	mm	Φ15.9	Φ15.9	Φ19.1
Dimension(WxDxH)	Outline	mm	900×340×1345	900×340×1345	900×340×1345
	Package	mm	1048×458×1507	1048×458×1507	1048×458×1507
Net weight/Gross weight		kg	112	112	112
Loading quantity	40' GP	set	57	57	57
	40' HQ	set	57	57	57

### 50Hz&60Hz (380~415V)

Model			GMV-120WL/C-X	GMV-140WL/C-X	GMV-160WL/C-X
Capacity range		HP	4	5	6
Capacity	Cooling	kW	12.1	14	16
	Heating	kW	14	16.5	18
EER		W/W	3.99	3.90	3.37
COP		W/W	4.28	4.18	3.87
Power supply		V/Ph/Hz	380-415/3/50&380-415/3/60		
Max. Circuit/Fuse Current		A	16	16	16
Power consumption	Cooling	kW	3.03	3.59	4.75
	Heating	kW	3.27	3.95	4.65
Maximum drive IDU NO.		unit	7	8	9
Refrigerant Charge volume		kg	3.3	3.3	3.3
Sound power level		dB(A)	68	69	69
Connecting pipe	Liquid	mm	Φ9.52	Φ9.52	Φ9.52
	Gas	mm	Φ15.9	Φ15.9	Φ19.1
Dimension(WxDxH)	Outline	mm	900×340×1345	900×340×1345	900×340×1345
	Package	mm	1048×458×1507	1048×458×1507	1048×458×1507
Net weight/Gross weight		kg	122	122	122
Loading quantity	40' GP	set	57	57	57
	40' HQ	set	57	57	57

## GMV5 SLIM

### GMV5 SLIM 50Hz&60Hz

Model			GMV-224WL/C-X	GMV-280WL/C-X	GMV-335WL/C-X
Capacity range		HP	8	10	12
Capacity	Cooling	kW	22.4	28	33.5
	Heating	kW	24	30	35
EER		W/W	3.66	3.6	3.5
COP		W/W	4.9	4.9	4.9
Power supply		V/Ph/Hz	380-415,3,50/60Hz		
Max. Circuit/Fuse Current		A	17.20	22.4	24.5
Power consumption	Cooling	kW	6.12	7.78	9.57
	Heating	kW	4.9	6.12	7.14
Maximum drive IDU NO.		unit	13	17	20
Refrigerant Charge volume		kg	5.5	7.1	8
Sound power level		dB(A)	74	74	76
Connecting pipe	Liquid	mm	9.52	9.52	12.7
	Gas	mm	19.05	22.2	25.4
Dimension (WxDxH)	Outline	mm	940x320x1430	940x460x1615	940x460x1615
	Package	mm	1038x438x1580	1038x578x1765	1038x578x1765
Net weight/Gross weight		kg	133	166	177
Loading quantity	40' GP	set	56	44	44
	40' HQ	set	56	44	44



# GMV5 Heat Recovery



## Key Features

### High Efficiency

GMV5 Heat Recovery System embodies the excellent features of GMV5 (DC inverter technology, DC fan linkage control, precise control of capacity output, balancing control of refrigerant, original oil balancing technology with high pressure chamber, high-efficiency output control, low-temperature operation control technology, super heating technology, high adaptability for project, environmental refrigerant). Its energy efficiency is improved by 78% compared with conventional multi VRF.

### Five Efficient Operation Modes

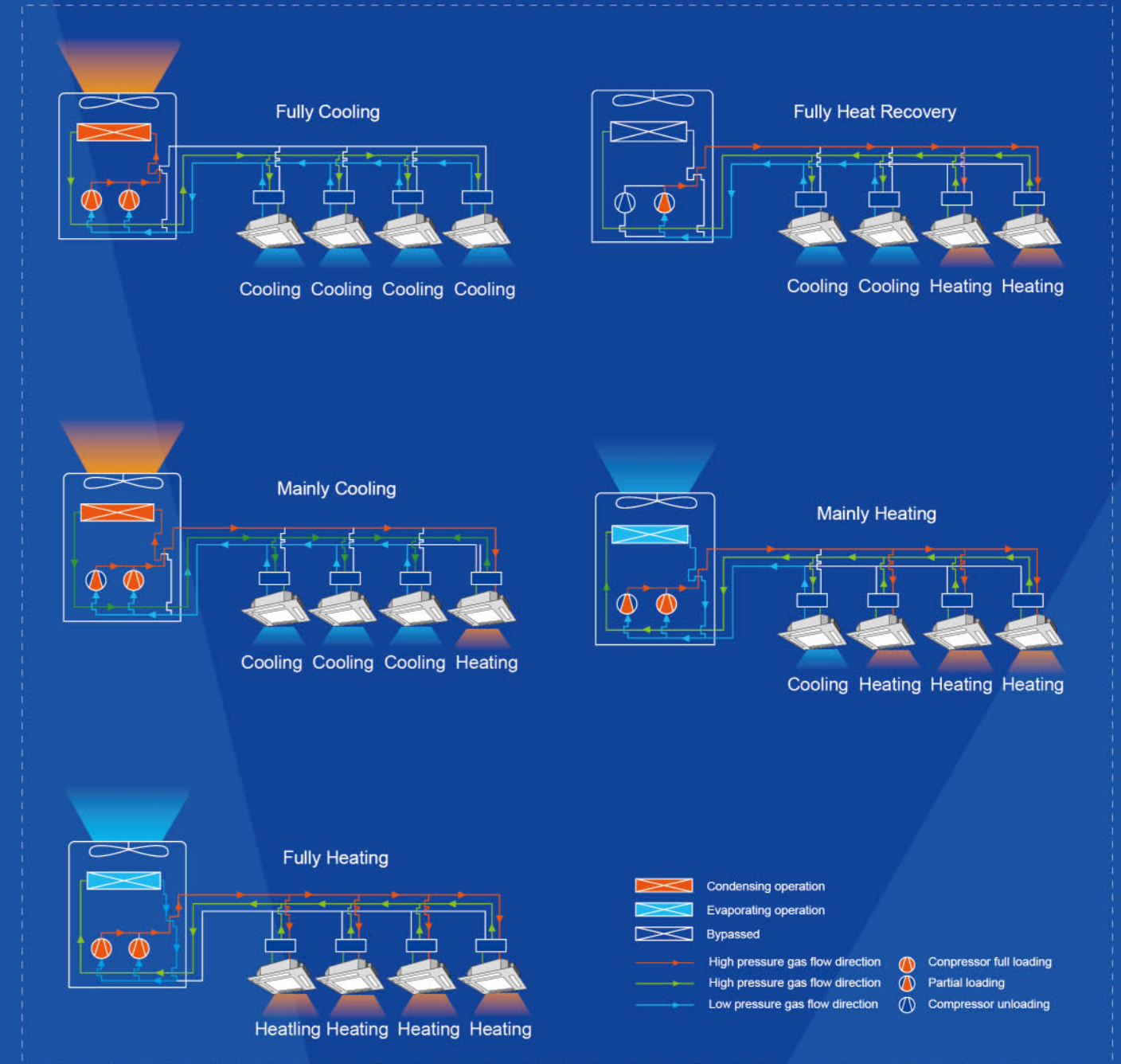



## All DC Inverter Technology to Improve Compression Efficiency

- All DC inverter compressor is used in this system. It can directly intake gas to reduce loss of overheat and improve efficiency.



- High-efficient permasyon motor is adopted to provide better performance than traditional DC inverter compressor.

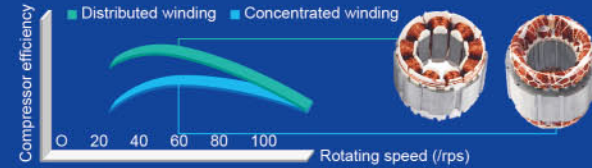

### High Pressure Chamber Design

#### What's high pressure chamber?

The low-temperature and low-pressure refrigerant gas inhaled from the suction inlet of compressor will change to high-temperature and high-pressure gas after compression by scroll plate. Then the gas will go out from the exhaust at the center of fixed scroll and get into the lower chamber of compressor, so that the chamber of compressor is in high temperature and high pressure.

#### What's the benefits of high pressure chamber?

High pressure chamber compressor inhales directly to reduce overheat suction loss and improve compression efficiency.

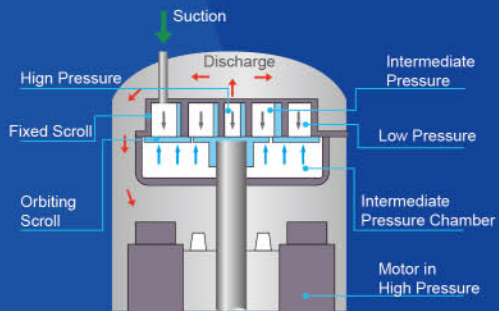

HP chamber structure can raise the high and middle frequency performance

New DC motor (concentrated winding) raises the low frequency performance

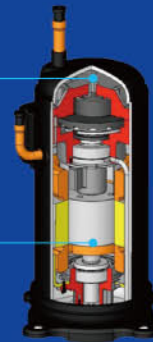

### Sensorless DC Inverter Fan Motor

Stepless speed regulation ranges from **5Hz** to **65Hz**. Compared with traditional inverter motors, the operation is more energy-saving.

Sensorless control technology guarantees lower noise, less vibration and steadier operation.

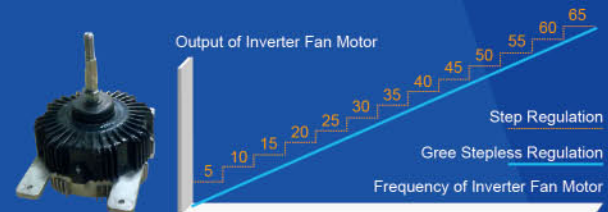

Before

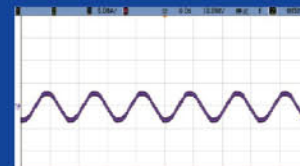

After

## Wide Range of Voltage to Ensure a Steady System Running

Working voltage range of GMV5 system has been improved to **320V-460V**, which surpasses the national standard of 342V-420V. For places with unsteady voltage, this system can still be running well.



## Wider Applicable Location

GMV5 HR can realize a combination of 4 outdoor unit modules connecting with as many as **80** indoor units. It's especially applicable for business building or hotels.



Max. IDU Connection: **80** sets



# Comfortable Design for A Better Life

## Intelligent Quiet Function at Night

- Quiet at night**  
Intelligently adjustment of outdoor fan control can minimize the noise during night time. Up to 8dB(A) can be reduced and operation noise at night is as low as 50dB(A).

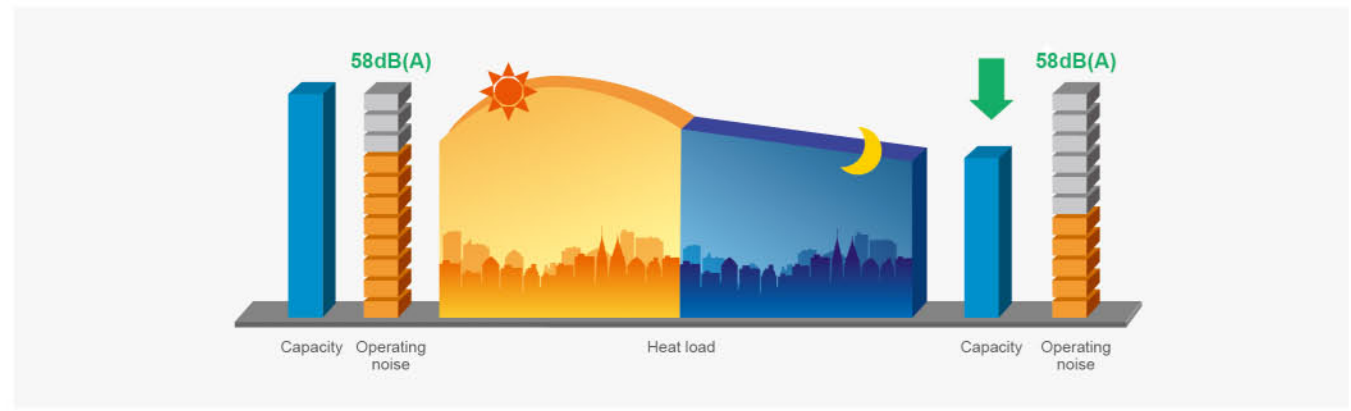

- Low noise design**  
HP Chamber compressor has lower exhaust pressure fluctuation so that noise is lower.

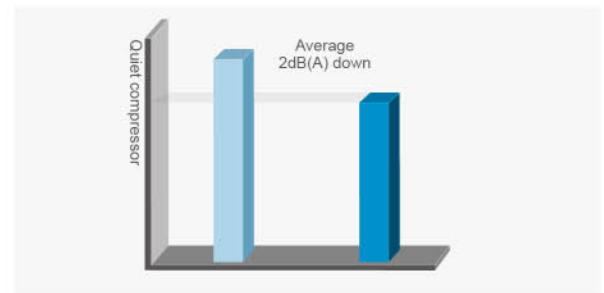

The optimized design of condensing fan blade reduces the air flow turbulence among blades, so that the noise is lower.

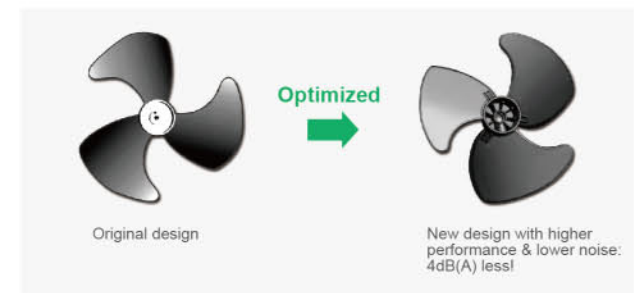

## Individual Control for More Energy Saving

The set temperature of each room may vary by the individual thermostat control of each indoor unit. The cooling and heating operation can be performed at the same time.



## Wide Operation Range

The unit can operate in wide range, greatly reducing the ambient temperature limitation.

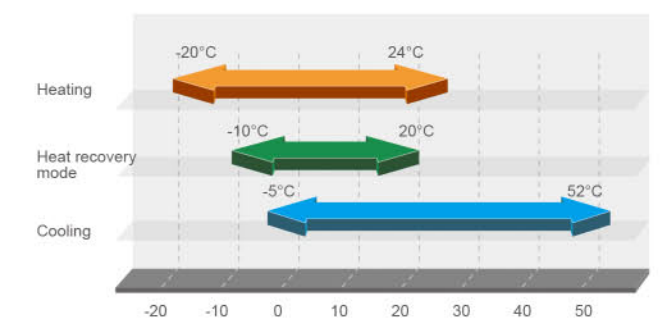

## Intelligent Defrosting Control

During the heating process, the frost status of the unit will be different after affecting by factors of outdoor ambient temperature, load status and operation time. Through real-time detection of operation parameters of the system, it can decide the defrosting time by intelligently estimating the thickness of frost, high pressure of system and blockage status of heat exchanger.

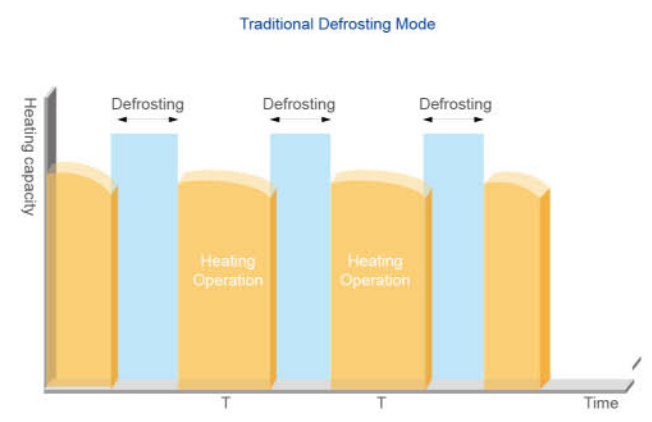



## Excellent Performance Ensured by Advanced Technology

### Modules Rotation Operating to Maximize Lifespan

#### Modules 8h rotation operating

The operating priority sequence of the outdoor unit modules will be changed without restart when the system accumulatively operates for 8 hours, which can maximize the service life of the system.



### Excellent Emergency Operation Function to Ensure Reliable Operation

#### Emergency Function

The GMV5 system can realize a combination of 4 outdoor unit modules. When error is occurred to one of the modules, the others will perform the emergency operation to sustain the air conditioning.



#### Emergency Operation of Compressor

All the compressors in each single module are DC Inverter based, when one compressor has error, others will perform the emergency operation.



#### Emergency Operation of Fan

Double-fan design ensures that one fan can still work even if the other one has error.

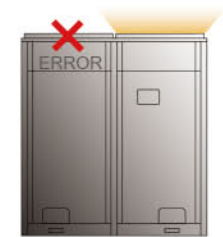

### Highly Anticorrosive Golden Fins

The primary material of Golden Fin is Al-Mn(Alumium-Manganese) anti-rust alloy, which is coated with the Golden Protection Layer(Components: Exoxy Resin & Modified Acrylic, Sillcon free), the anti-corrosive performance in salt-spray testing is 200%~300% higher than normal Blue Fin\*.

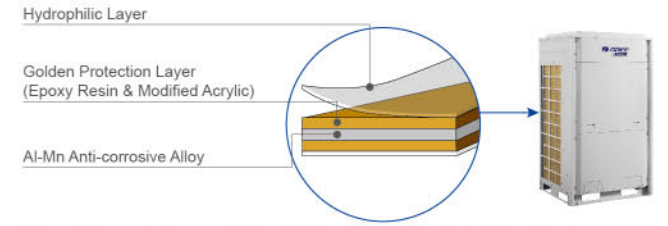

Note: Salt-spray testing result is from GREE materials chemistry testing laboratory.

### Oil Return Control Technology

#### New Oil Return Control

Gree new oil return control technology effectively controls system oil return and oil storage status of each compressor, which greatly improves the operation lifespan of compressor.

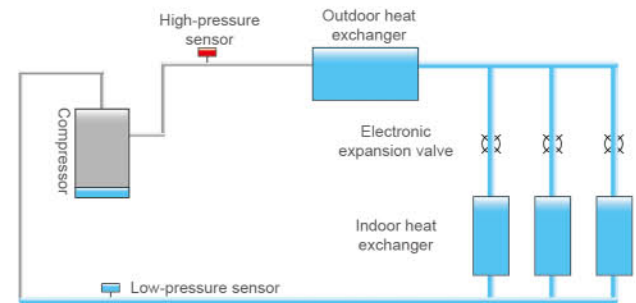

Oil storage status before oil return

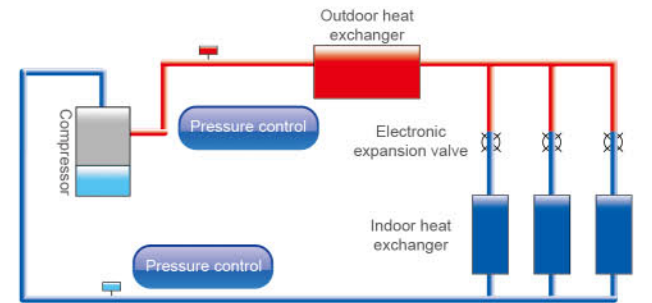

Oil return operation

#### Specialized Compressor Oil Storage Control

The system applies specialized compressor oil storage technology, which can control the lowest oil level for compressor operation.

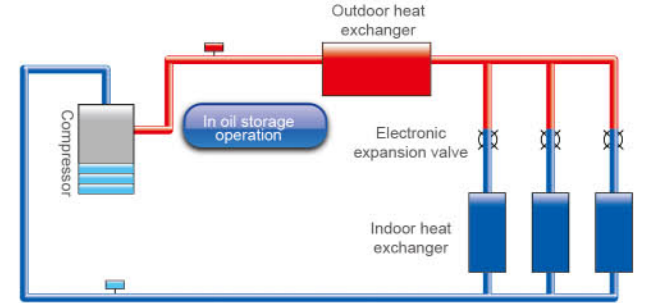

Oil storage operation

### Without External Oil-balanced Pipe Design

The unit is without external oil-balanced pipe design, reducing system pipeline connection and easy for engineering installation. The system will allocate lubricating oil of each module according to its demand, which is more intelligent, more efficient and more equal.

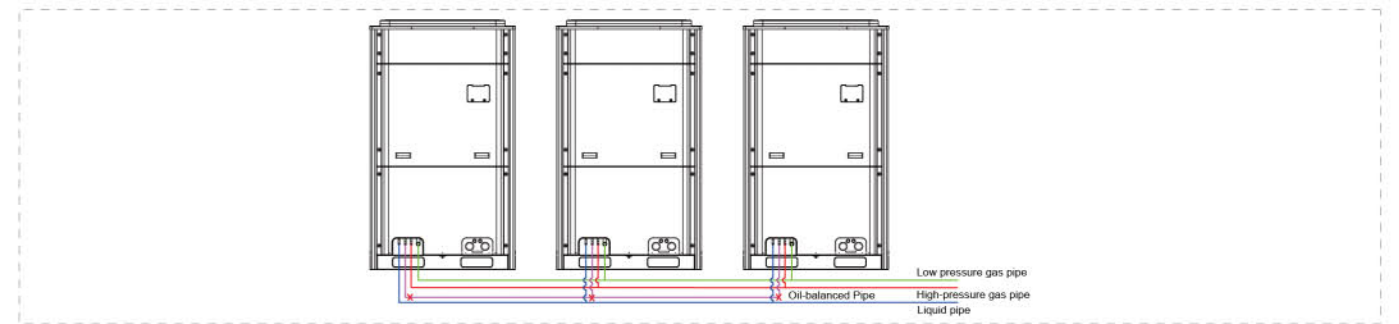



# Easy Installation and Maintenance

## Compact Design

With compact design, the outdoor unit can be carried to the roof of building through elevator, with no need of crane. It is easier for delivery and installation.



## Easy Transportation

**Optimized base frame**  
Optimized base frame, the locating and fixing of the outdoor unit during installation is more convenient and reliable.



**Transportable by forklift**

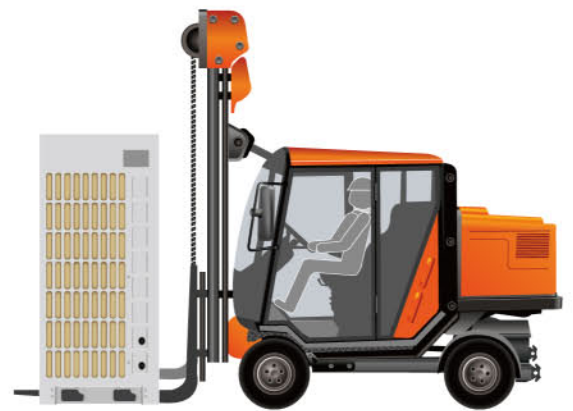

**Five-way piping connection**  
Piping and wiring are available to the front and back, left and right, and bottom.  
The five-way piping connection reduces installation difficulty and cost, improves the installation efficiency.



## Easy Maintenance

Inspection window is available for quick checking of system operation status. No need to open panel for checking, which will be more time-saving and easier for maintenance.

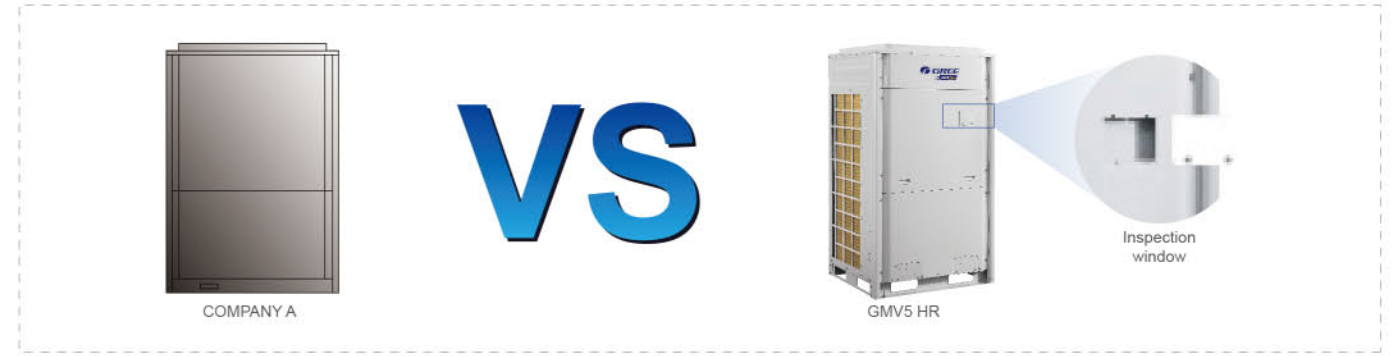

**Error Display & Self-diagnostic Function**  
Through LED display (different combinations of ON, OFF, or BLINK) on the main board, the malfunction can be judged.





# GMV5 HR Lineup

## GMV5 HR Lineup

HP	Model	Product Outlook
8HP	GMV-Q224WM/E-X	
10HP	GMV-Q280WM/E-X	
12HP	GMV-Q335WM/E-X	
14HP	GMV-Q400WM/E-X	
16HP	GMV-Q450WM/E-X	

Model	Product Outlook
NCHS1C	
NCHS2C	
NCHS4C	
NCHS8C	

## Specifications and Parameters

50/60 Hz

Model			GMV-Q224WM/E-X	GMV-Q280WM/E-X	GMV-Q335WM/E-X	GMV-Q400WM/E-X	GMV-Q450WM/E-X
Capacity range	HP		8	10	12	14	16
Capacity	Cooling	kW	22.4	28	33.5	40	45
	Heating	kW	25	31.5	37.5	45	50
EER	kW/kW		4.09	3.44	4.04	3.36	3.04
COP	kW/kW		4.75	4.32	4.87	4.5	3.94
Power supply	V/Ph/Hz		380~415V 3Ph 50/60Hz				
Max. Circuit/Fuse Current	A		16.3/20	20.9/25	24.7/32	28.8/40	33.2/40
Power consumption	Cooling	kW	5.48	8.15	8.3	11.9	14.8
	Heating	kW	5.26	7.3	7.7	10	12.7
Maximum drive IDU NO.	unit		13	16	19	23	26
Refrigerant Charge volume	kg		6.2	7.1	9.6	11.1	11.6
Sound power level	Cooling	dB(A)	82	84	85	90	90
Sound pressure level	Cooling	dB(A)	60	61	63	63	63
Connecting pipe	Liquid	mm	Φ9.52	Φ9.52	Φ12.7	Φ12.7	Φ12.7
	High Pressure Gas	mm	Φ15.9	Φ19.05	Φ19.05	Φ22.2	Φ22.2
	Low Pressure Gas	mm	Φ19.05	Φ22.2	Φ25.4	Φ25.4	Φ28.6
Dimension(WxDxH)	Outline	mm	930×765×1605	930×765×1605	1340×765×1605	1340×765×1605	1340×765×1605
	Package	mm	1010×840×1775	1010×840×1775	1420×840×1775	1420×840×1775	1420×840×1775
Net weight/Gross weight	kg		233/243	233/243	302/317	346/361	346/361
Loading quantity	40' GP	set	24	24	16	16	16
	40' HQ	set	24	24	16	16	16

50/60 Hz

Model			NCHS1C	NCHS2C	NCHS4C	NCHS8C
Max.IDU Branches	unit		1	2	4	8
No. of connectable IDU of each branch	unit		8	8	8	8
Total Connectable IDU	unit		8	16	32	64
Max. Capacity of each branch	kW		14.2	14.2	14.2	14.2
Max. Capacity of connectable IDU	kW		14.2	28	45	68
Power supply	V/Ph/Hz		220~240V 1Ph 50/60Hz			
Power consumption	W		8	28	44	80
Max. branch quantity of connecting IDU	unit		1	2	4	8
Outdoor Unit Piping Connection	Liquid	mm	Φ9.52	Φ9.52	Φ12.7	Φ15.9
	Gas(Low pressure)	mm	Φ22.2			
	Gas(High pressure)	mm	Φ15.9	Φ19.05	Φ22.2	Φ22.2
Indoor Unit Piping Connection	Liquid	mm	Φ9.52	Φ9.52	Φ9.52	Φ9.52
	Gas	mm	Φ15.9	Φ15.9	Φ15.9	Φ15.9

Note: GMV-Q\*\*WM/E-X and NCHS\*C are fixed match, which cannot be matched with the outdoor units and mode exchangers of other types.

## ODU Combination Lineup-GMV5 HR\*

Model	GMV-Q224WM/E-X	GMV-Q280WM/E-X	GMV-Q335WM/E-X	GMV-Q400WM/E-X	GMV-Q450WM/E-X
GMV-Q224WM/E-X	●				
GMV-Q280WM/E-X		●			
GMV-Q335WM/E-X			●		
GMV-Q400WM/E-X				●	
GMV-Q450WM/E-X					●
GMV-Q504WM/E-X	●	●			
GMV-Q560WM/E-X		●●			
GMV-Q615WM/E-X		●	●		
GMV-Q680WM/E-X		●		●	
GMV-Q730WM/E-X		●			●
GMV-Q785WM/E-X			●		●
GMV-Q850WM/E-X				●	●
GMV-Q900WM/E-X					●●
GMV-Q960WM/E-X		●●		●	
GMV-Q1010WM/E-X		●●			●
GMV-Q1065WM/E-X		●	●		●
GMV-Q1130WM/E-X		●		●	●
GMV-Q1180WM/E-X		●			●●
GMV-Q1235WM/E-X			●		●●
GMV-Q1300WM/E-X				●	●●
GMV-Q1350WM/E-X					●●●
GMV-Q1410WM/E-X		●●		●	●
GMV-Q1460WM/E-X		●●			●●
GMV-Q1515WM/E-X		●	●		●●
GMV-Q1580WM/E-X		●		●	●●
GMV-Q1630WM/E-X		●			●●●
GMV-Q1685WM/E-X			●		●●●
GMV-Q1750WM/E-X				●	●●●
GMV-Q1800WM/E-X					●●●●

Note\*: The combination models of the outdoor units are not Eurovent certified.



## Specification of ODU Combination of GMV5 HR\*

Model	Power Supply	Capacity		Power Input		Dimension(W×D×H) mm	Airflow Volume m³/h	ESP Pa	Connecting pipe diameter			Min. circuit current A	Max. fuse current A	Weight kg
		Cooling kW	Heating kW	Cooling kW	Heating kW				Liquid mm	HP Gas mm	LP Gas mm			
GMV-Q224WME-X		22.4	25.0	5.48	5.26	930×765×1605	11400	82	Φ9.52	Φ15.9	Φ19.05	16.3	20	233
GMV-Q280WME-X		28	31.5	8.15	7.30	930×765×1605	11400	82	Φ9.52	Φ19.05	Φ22.2	20.9	25	233
GMV-Q335WME-X		33.5	37.5	8.30	7.70	1340×765×1605	14000	82	Φ12.7	Φ19.05	Φ25.4	24.7	32	302
GMV-Q400WME-X		40	45.0	11.90	10.00	1340×765×1605	14000	82	Φ12.7	Φ22.2	Φ25.4	28.8	40	346
GMV-Q450WME-X		45	50.0	14.80	12.70	1340×765×1605	14000	82	Φ12.7	Φ22.2	Φ28.6	33.2	40	346
GMV-Q504WME-X		50.4	56.5	13.63	12.56	(930×765×1605) ×2	11400×2	82	Φ15.9	Φ25.4	Φ28.6	37.2	40	233+233
GMV-Q560WME-X		56	63.0	16.30	14.60	(930×765×1605) ×2	11400×2	82	Φ15.9	Φ25.4	Φ28.6	41.8	50	233+233
GMV-Q615WME-X		61.5	69.0	16.45	15.00	(930×765×1605) + (1340×765×1605)	11400+14000	82	Φ15.9	Φ25.4	Φ28.6	45.6	50	233+302
GMV-Q680WME-X		68	76.5	20.05	17.30	(930×765×1605) + (1340×765×1605)	11400+14000	82	Φ15.9	Φ25.4	Φ28.6	49.7	63	233+346
GMV-Q730WME-X		73	81.5	22.95	20.00	(930×765×1605) + (1340×765×1605)	11400+14000	82	Φ19.05	Φ28.6	Φ31.8	54.1	63	233+346
GMV-Q785WME-X		78.5	87.5	23.10	20.40	(1340×765×1605) ×2	14000×2	82	Φ19.05	Φ28.6	Φ31.8	57.9	63	302+346
GMV-Q850WME-X		85	95.0	26.70	22.70	(1340×765×1605) ×2	14000×2	82	Φ19.05	Φ28.6	Φ31.8	62	63	346+346
GMV-Q900WME-X		90	100.0	29.60	25.40	(1340×765×1605) ×2	14000×2	82	Φ19.05	Φ28.6	Φ31.8	66.4	80	346+346
GMV-Q960WME-X		96	108.0	28.20	24.60	(930×765×1605) ×2 +(1340×765×1605)	11400×2+14000	82	Φ19.05	Φ28.6	Φ31.8	70.6	80	233×2+346
GMV-Q1010WME-X	380-415V	101	113.0	31.10	27.30	(930×765×1605) ×2 +(1340×765×1605)	11400×2+14000	82	Φ19.05	Φ31.8	Φ38.1	75	80	233×2+346
GMV-Q1065WME-X	3Ph 50/60Hz	106.5	119.0	31.25	27.70	(930×765×1605) + (1340×765×1605)×2	11400+14000×2	82	Φ19.05	Φ31.8	Φ38.1	78.8	80	233+302+346
GMV-Q1130WME-X		113	126.5	34.85	30.00	(930×765×1605) + (1340×765×1605)×2	11400+14000×2	82	Φ19.05	Φ31.8	Φ38.1	82.9	100	233+346×2
GMV-Q1180WME-X		118	131.5	37.75	32.70	(930×765×1605) + (1340×765×1605)×2	11400+14000×2	82	Φ19.05	Φ31.8	Φ38.1	87.3	100	233+346×2
GMV-Q1235WME-X		123.5	137.5	37.90	33.10	(1340×765×1605)×3	14000×3	82	Φ19.05	Φ31.8	Φ38.1	91.1	100	302+346×2
GMV-Q1300WME-X		130	145.0	41.50	35.40	(1340×765×1605)×3	14000×3	82	Φ19.05	Φ31.8	Φ38.1	95.2	100	346×3
GMV-Q1350WME-X		135	150.0	44.40	38.10	(1340×765×1605)×3	14000×3	82	Φ19.05	Φ31.8	Φ38.1	99.6	125	346×3
GMV-Q1410WME-X		141	158.0	43.00	37.30	(930×765×1605) ×2+ (1340×765×1605)×2	11400×2+14000×2	82	Φ19.05	Φ38.1	Φ41.3	103.8	125	233×2+346×2
GMV-Q1460WME-X		146	163.0	45.90	40.00	(930×765×1605) ×2+ (1340×765×1605)×2	11400×2+14000×2	82	Φ19.05	Φ38.1	Φ41.3	108.2	125	233×2+346×2
GMV-Q1515WME-X		151.5	169.0	46.05	40.40	(930×765×1605) + (1340×765×1605)×3	11400+14000×3	82	Φ19.05	Φ38.1	Φ41.3	112	125	233+302+346×2
GMV-Q1580WME-X		158	176.5	49.65	42.70	(930×765×1605) + (1340×765×1605)×3	11400+14000×3	82	Φ19.05	Φ38.1	Φ41.3	116.1	125	233+346×3
GMV-Q1630WME-X		163	181.5	52.55	45.40	(930×765×1605) + (1340×765×1605)×3	11400+14000×3	82	Φ19.05	Φ38.1	Φ41.3	120.5	125	233+346×3
GMV-Q1685WME-X		168.5	187.5	52.70	45.80	(1340×765×1605)×4	14000×4	82	Φ19.05	Φ38.1	Φ41.3	124.3	160	302+346×3
GMV-Q1750WME-X		175	195.0	56.30	48.10	(1340×765×1605)×4	14000×4	82	Φ19.05	Φ38.1	Φ41.3	128.4	160	346×4
GMV-Q1800WME-X		180	200.0	59.20	50.80	(1340×765×1605)×4	14000×4	82	Φ19.05	Φ38.1	Φ41.3	132.8	160	346×4

Note\*: The combination models of the outdoor units are not Eurovent certified.

## Key Features of Indoor Units

### High Static Pressure Duct Type Indoor Unit



- **High static pressure design**  
Static pressure can be up to 150Pa, especially suitable for places in need of long distance airflow.

- **Easy maintenance**  
The system has maintenance port for easy maintenance.

- **Convenient installation**  
You can choose circular air duct or rectangular air duct according to actual needs. Or you can choose different ways of air return.

- **Protection function**  
Anti-freezing protection, fan motor overload protection, temperature sensor malfunction protection.



## Low Static Pressure Duct Type Indoor Unit



- **Low static pressure, low noise**

Especially suitable for rooms of compact structure or small installation space. Also, it provides you with a comfortable and quiet living environment.

- **Intelligent drainage device**

Water height difference up to 1.0m, which can effectively drain out condensing water and save space.

Note: Please specify if you need this function.

- **Convenient installation**

Tab type plastic filter, detachable fan motor, independent water pump assembly and electric box assembly, all for convenient maintenance.

- **Protection function**

Water overflow protection, anti-freezing protection, fan motor overload protection, temperature sensor malfunction protection.

## Slim Ducted Type Indoor Unit



- **Highly Efficient & Energy-saving**

High-efficiency DC brushless motor is used. Its efficiency is improved by over 30% compared with common motor. Evaporator flow path adopts simulating optimized design via the refrigeration system simulation software, which has greatly increased the heat exchange capacity of evaporator.

- **Slim & Small**

The unit is only 200mm's thick and 450mm's deep. Suspended ceiling doesn't have to be very high. It is suitable for ordinary rooms.

- **Wiring of Electric Control Box**

Mounting board of electric control box elements are arranged at both sides of the mounting board of fan motor. There is a wire-cross notch on each side so that wiring at both sides of the mounting board of fan motor is convenient and efficient. Strong and weak current are also separated to ensure the effectiveness of weak current signal transmission.

- **Protection Functions**

Anti-freezing protection, fan motor built-in overload protection, temperature sensor error protection

- **Ultra-quiet**

High-efficiency centrifugal fan and ultralow noise volute are developed with ANSYS and Fluent. They have also gained national patents. Meanwhile, inlet mute valve is adopted so that noise of the complete unit is greatly reduced.

- **Fast & Strong**

Intelligent temperature control technology is adopted. Cooling/ Heating function is fast and strong so that room temperature can quickly reach set temperature.

- **Flexible Installation**

Based on the requirements of building and utilization, different ways of air return and different air supply static pressure can be selected.

- **CAN Bus Communication Technology**

System response speed is faster and communication is more reliable. Auto addressing, non-polar communication, free wire matching

- **Convenient Operation & Maintenance**

Electric control box is attached independently so that it can be detached as a whole, which is convenient for maintenance. The installation and maintenance of fan and motor is also convenient.



## 4-way Cassette Indoor Unit

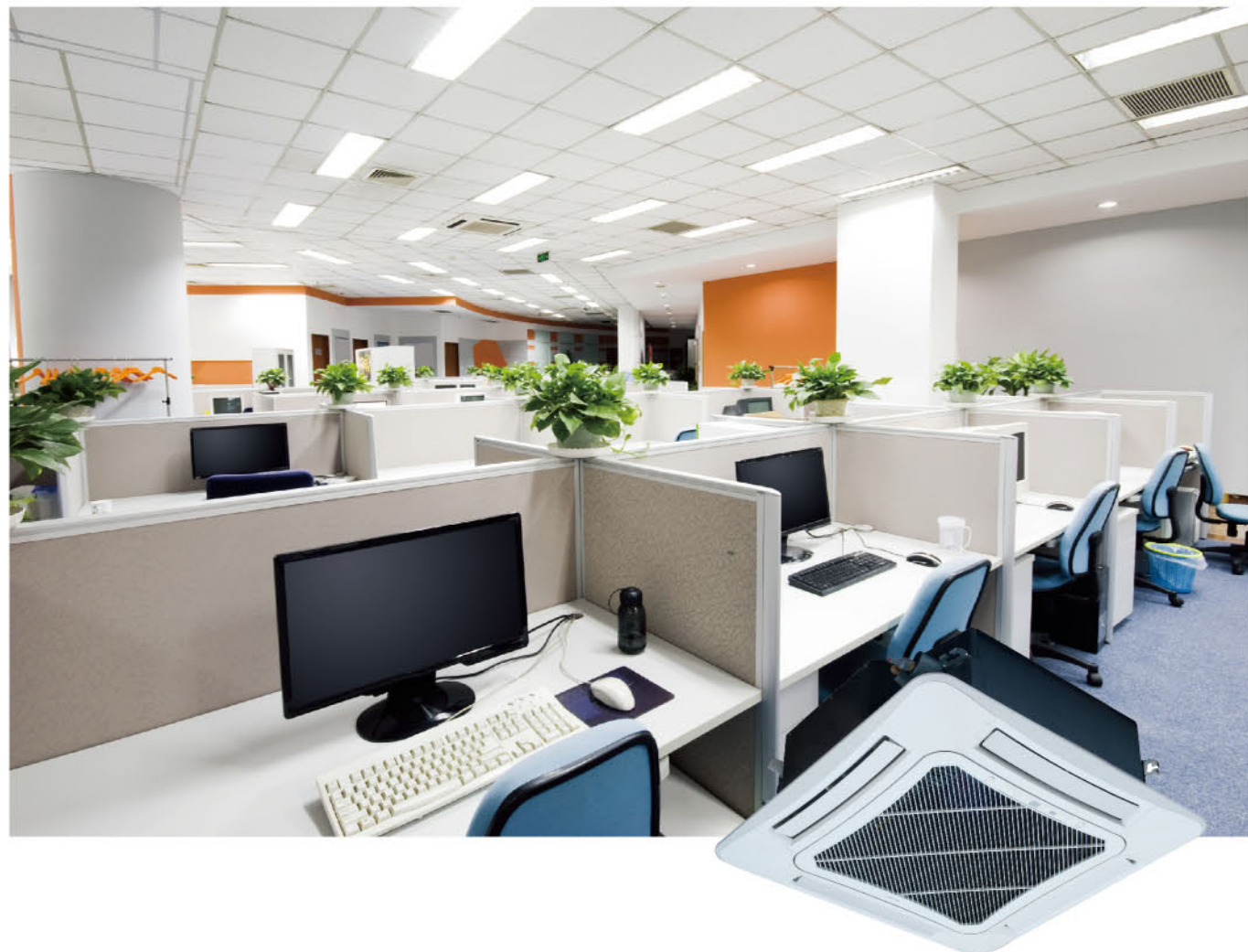

- **Strong and balanced airflow**

Unit features auto operation, 4-way airflow, 7 fan speeds and strong circulating airflow.

- **Ultra-low noise operation**

DC inverter motor can realize stepless speed regulation to lower noise. Indoor unit can be set to work under auto quiet mode via wired controller.

- **Intelligent drainage device**

Water height difference up to 1.0m, which can effectively drain out condensing water and save space.

- **DC inverter motor**

With good speed regulation performance, motor efficiency improved by 30% v.s. normal motor.

- **Protection function**

Water overflow protection, anti-freezing protection, temperature sensor malfunction protection, fan motor overload protection.

## Compact 4-way Cassette Indoor Unit



- **Compact Design for Easy Installation**

Units maintain the uniform length and width with consistent ceiling opening and panel dimension, convenient for design and installation;

- **Ultra-low noise operation**

DC inverter motor can realize stepless speed regulation to lower noise. Indoor unit can be set to work under auto quiet mode via wired controller.

- **Intelligent drainage device**

Water height difference up to 1.0m, which can effectively drain out condensing water and save space.



## 2-way Cassette Indoor Unit

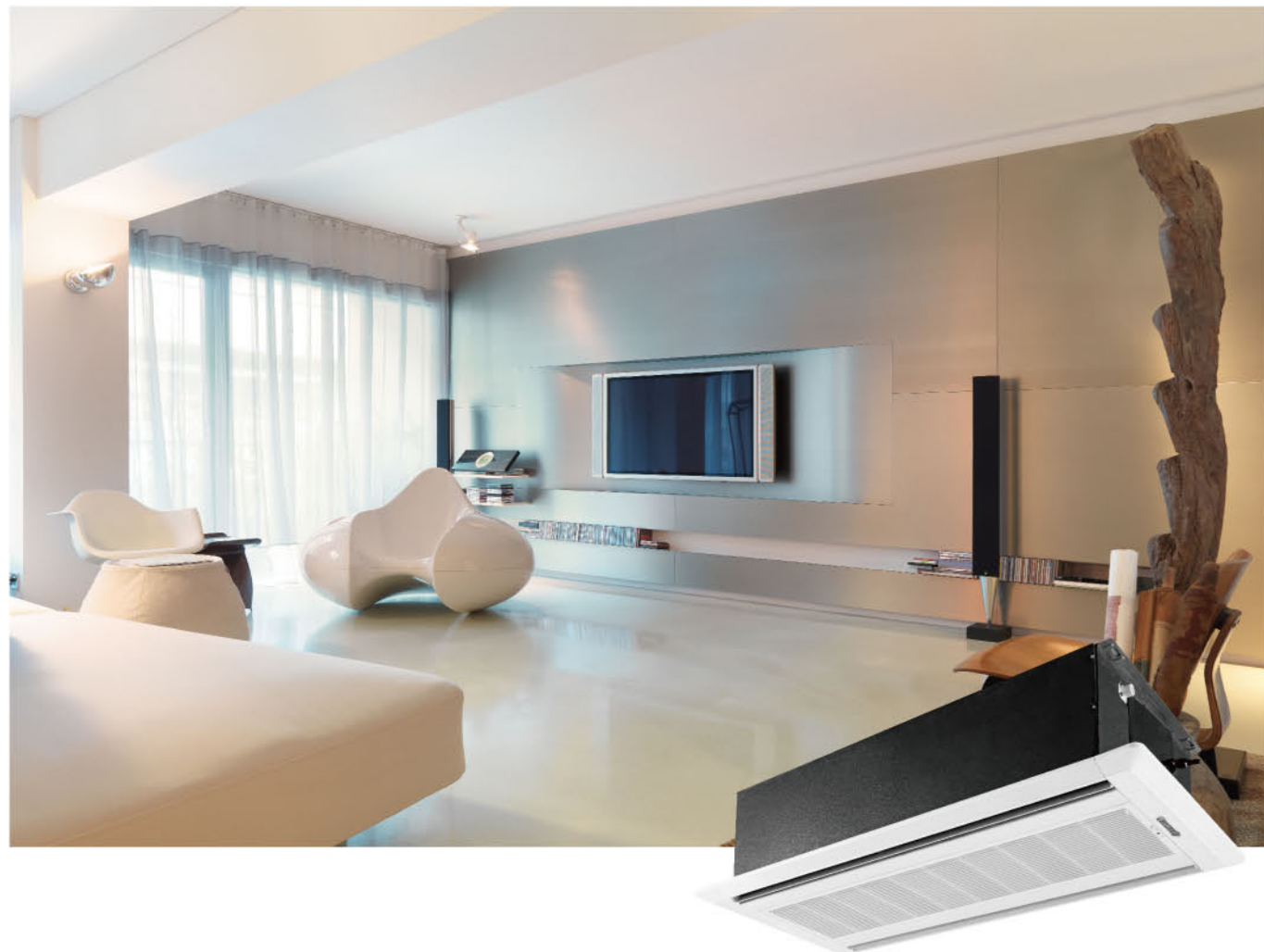

- **Beautiful Appearance**

With beautiful and elegant front panel, it is congenial to the indoor surroundings.

- **Intelligent drainage device**

Water height difference up to 1.0m, which can effectively drain out condensing water and save space.

- **Two-way air flow design**

Two-way air outlet, to stretch air outlet distance and solve air supply problem of elongated room

- **Multiple protections**

Anti-freezing protection, temperature malfunction protection, fan motor overload and humidity sensor protection.

## 1-way Cassette Indoor Unit



- **Small installation space**

With 185mm ultrathin design, unit can be installed in the ceiling of 19cm deep.

- **Detachable grille and long life filter**

Grille is detachable for easy cleaning. With durable filter, cleaning cycle is 20 times longer.

- **High drain pump lift**

Drain pump lift reaches 1.0m, which can effectively drain out water.

- **Protection function**

Water overflow protection, anti-freezing protection, fan motor overload protection, temperature sensor malfunction protection.



## Wall-mounted Indoor Unit



- **Comfortable and balanced airflow, up&down air outlet**

Up air outlet: In cooling, cool air blows out horizontally and then gradually drops.

Down air swing: In heating, warm air blows downward and then gradually climbs up.

- **Triple defenders for better purification**

Mildew-proof filter, electrostatic fibre and anti-biotic fibre adopted to remove dust, smell, bacteria and mildew.

- **Cold air prevention design**

During heating in winter, cold air prevention function is enabled so that air won't be blown out until it's warm.

- **Multiple protections**

Anti-freezing protection, temperature sensor malfunction protection, fan motor overload protection.

## Floor Ceiling Type Indoor Unit



- **Hoisted or seated, flexible installation**

Unit can be hoisted or seated. When seated, suspended ceiling is not needed.

- **Beautiful appearance**

With beautiful and elegant front panel, it is congenial to the indoor surroundings.

- **Protection function**

Anti-freezing protection, temperature sensor malfunction protection, fan motor overload protection.

- **Horizontal and vertical air swing**

Wider air swing range for your comfortable working and living environment.



## Console Indoor Unit



- Multiple fan speed**  
 The fan can operate in multiple speed and satisfy different air flow volume requirements.
- Detachable grille and long life filter**  
 Grille is detachable for easy cleaning. With long life filter, cleaning cycle is 20 times longer.
- Protection function**  
 Anti-freezing protection, fan motor overload protection, temperature sensor malfunction protection.

## Floor Standing Indoor Unit



- Wide application**  
 It can be widely adopted in hotels, restaurants, office, etc.
- Auto clean to ensure a healthy life**  
 After turning off the unit, the indoor fan will keep running in low speed for a moment to dry the inner components and parts, in order to prevent mildew and keep user healthy.





**Wide capacity range**

Wide capacity range from 2.2kW to 7.1kW.

**DC motor**

DC motor is adopted, which is more efficient. All units are only 200mm's thick, saving space while offering highly efficient performance.

**Easy installation**

High ESP allows installation with air ducts. The low altitude design allows installation under a window. It is applicable for hotels, schools and office buildings. The three different height choices\* of ex-factory supporter satisfy users' different installation needs.

\*Note: This is an optional function. Please state specifically if you want to order.

**Fresh Air Processing Indoor Unit**

Airflow volume: 1200~4000m<sup>3</sup>/h  
 Applicable range: Residential houses, villas, business buildings, hotels, apartments, etc.



**One system, two functions**

- Adopted with DC inverter technology, Fresh Air DC Inverter Multi VRF System features air conditioning function and fresh air function.

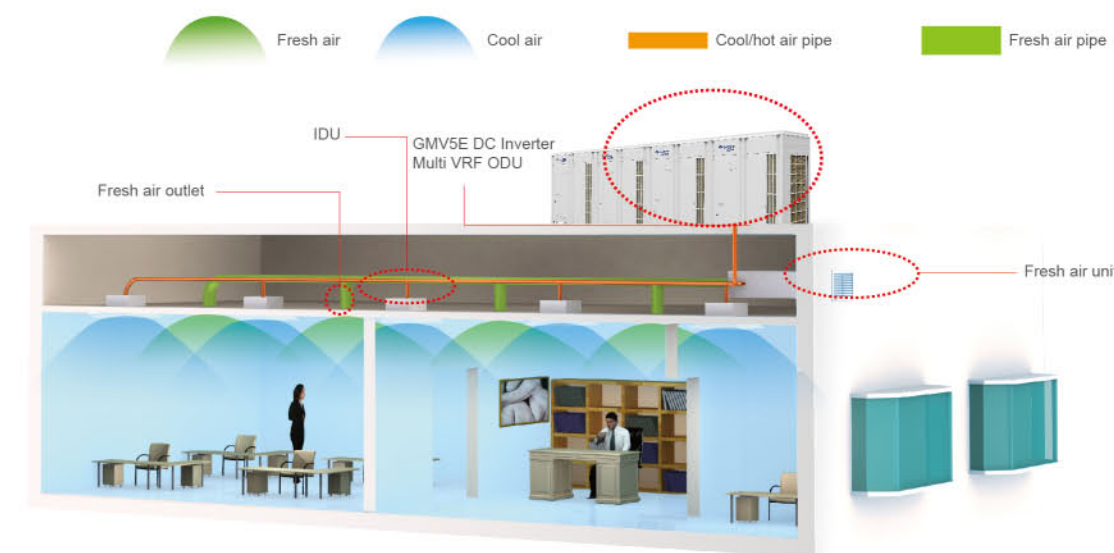

**Enjoy fresh air**

- Airflow volume: 1200~4000m<sup>3</sup>/h, cooling capacity: 14-45kW. Applicable for all kinds of structure.
- Direct evaporative cooling adopted, air conditioning+fresh air can be realized accurately and precisely.
- DC inverter technology adopted, constant humidity is enabled with less power consumption.
- Integrated system control with Gree GMV Multi VRF System.

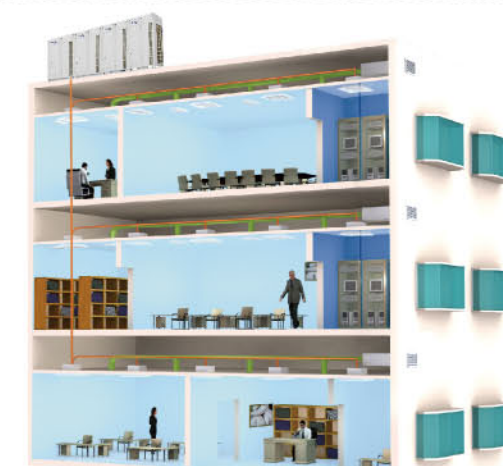



## Air conditioning and fresh air, two in one

### • Less investment

Fresh Air DC Inverter Multi VRF System can be combined with Gree GMV5E. For a same room, if the same amount of fresh air is to be taken, then the cost of GMV5E+Fresh air unit is equivalent to the cost of GMV+Air exchange fan.

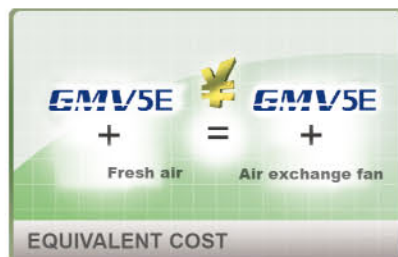

### • Less operation cost

Unit can control refrigerant output according to actual needs to ensure constant airflow temperature. By adjusting power output, light-load but high power operation can be avoided. Thus, operation cost can be greatly reduced.



### • Less installation space

Save installation space for outdoor units. Especially suitable for places that have restricted installation space.

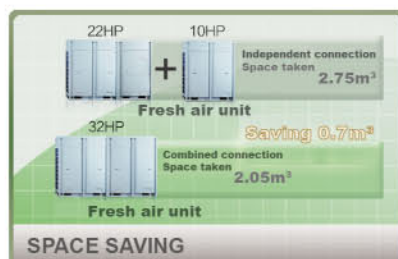

## AHU KIT

### • Maximum capacity

Capacity of single unit reaches 20HP.

### • Convenient for installation

EXV is separated from control box, flexible for installation.

### • Adjustable capacity

Adjust capacity by DIP switch code, flexible and convenient.



## Indoor Units Lineup

### Specifications of Indoor Units

Type of indoor unit	Specification	20	22	25	28	32	36	40	45	50	56	63	71	72	80	90	100	112	125	140	160	224	280	450	560
High Static Pressure Duct Type Unit		•	•	•	•	•	•	•	•	•	•	•	•	•	•	•	•	•	•	•	•	•	•	•	•
Low Static Pressure Duct Type Unit			•	•	•	•	•	•	•	•	•	•	•	•	•	•	•	•	•	•	•	•	•	•	•
Slim Ducted Type Indoor Unit			•	•	•	•	•	•	•	•	•	•	•	•	•	•	•	•	•	•	•	•	•	•	•
4-way Cassette Unit					•	•	•	•	•	•	•	•	•	•	•	•	•	•	•	•	•	•	•	•	•
Compact 4-way Cassette Indoor Unit			•	•	•	•	•	•	•	•	•	•	•	•	•	•	•	•	•	•	•	•	•	•	•
2-way Cassette Indoor Unit					•	•	•	•	•	•	•	•	•	•	•	•	•	•	•	•	•	•	•	•	•
1-way Cassette Unit			•	•	•	•	•	•	•	•	•	•	•	•	•	•	•	•	•	•	•	•	•	•	•
Wall-mounted Type Unit			•	•	•	•	•	•	•	•	•	•	•	•	•	•	•	•	•	•	•	•	•	•	•
Floor Ceiling Type Indoor Unit					•	•	•	•	•	•	•	•	•	•	•	•	•	•	•	•	•	•	•	•	•
Console Indoor Unit			•	•	•	•	•	•	•	•	•	•	•	•	•	•	•	•	•	•	•	•	•	•	•
Floor Standing Type Indoor Unit																									
Fresh Air Processing Indoor Unit																									
AHU KIT																									
Concealed Floor Standing Type			•	•	•	•	•	•	•	•	•	•	•	•	•	•	•	•	•	•	•	•	•	•	•



# High Static Pressure Duct Type Indoor Unit

50/60 Hz

Model			GMV-ND56PHS/A-T	GMV-ND63PHS/A-T	GMV-ND71PHS/A-T	GMV-ND80PHS/A-T	GMV-ND90PHS/A-T	
Capacity	Cooling	kW	5.6	6.3	7.1	8.0	9.0	
	Heating	kW	6.3	7.1	8.0	9.0	10.0	
Power supply	V/Ph/Hz		220~240/1/50 & 208~230/1/60					
Power consumption	W		120	120	130	130	200	
Airflow volume(H/M/L)	m³/h		1000/800/600	1000/800/600	1100/900/700	1100/900/700	1700/1450/1100	
	CFM		590/471/355	590/471/355	650/530/410	650/530/410	1000/853/650	
Rated Current	Cooling	A	0.6	0.6	0.6	0.6	1.0	
	Heating	A	0.6	0.6	0.6	0.6	1.0	
	Water Heating	A	/	/	/	/	/	
ESP	Pa		70/0~100					
Sound pressure level(H/M/L)	dB(A)		44/40/36	44/40/36	45/41/37	45/41/37	46/44/42	
Connecting pipe diameter	Liquid	mm	Φ9.52	Φ9.52	Φ9.52	Φ9.52	Φ9.52	
	Gas	mm	Φ15.9	Φ15.9	Φ15.9	Φ15.9	Φ15.9	
Drain pipe	External dia.	mm	Φ25	Φ25	Φ25	Φ25	Φ25	
	Thickness	mm	2.5	2.5	2.5	2.5	2.5	
Dimension (WxDxH)	Outline	mm	1271x558x268					1229x775x290
	Package	mm	1348x597x283					1338x877x305
Net weight/Gross weight	kg		35/40	35/40	35/40	35/40	47/54	
Loading	40' GP	set	192	192	192	192	128	
	40' HQ	set	216	216	216	216	128	

Model			GMV-NDR56PH/B1-T	GMV-NDR63PH/B1-T	GMV-NDR71PH/B1-T	GMV-NDR80PH/B1-T	GMV-NDR90PH/B1-T	GMV-NDR100PH/B1-T	GMV-NDR112PH/B1-T
Capacity	Cooling	kW	5.6	6.3	7.1	8	9	10	11.2
	Heating	kW	6.3	7.1	8	9	10	11.2	12.5
Power supply	V/Ph/Hz		220~240/1/50 & 208~230/1/60						
Power consumption	W		525	650	760	866	866	864	866
Airflow volume(H/M/L)	m³/h		3650	3850	4160	4250	4250	4250	4250
	CFM		2148	2266	2448	2501	2501	2501	2501
Rated Current	Cooling	A	2.9	3.6	4.2	4.7	4.7	4.8	4.8
	Heating	A	2.9	3.6	4.2	4.7	4.7	4.8	4.8
	Water Heating	A	/	/	/	/	/	/	/
ESP	Pa		25/25~200	25/25~200	25/25~200	37/37~200	37/37~200	37/37~200	37/37~200
Sound pressure level(H/M/L)	dB(A)		52	52	52	52	52	52	52
Connecting pipe diameter	Liquid	mm	Φ9.52	Φ9.52	Φ9.52	Φ9.52	Φ9.52	Φ9.52	Φ9.52
	Gas	mm	Φ19.05	Φ19.05	Φ19.05	Φ19.05	Φ19.05	Φ19.05	Φ19.05
Drain pipe	External dia.	mm	Φ30	Φ30	Φ30	Φ30	Φ30	Φ30	Φ30
	Thickness	mm	1.5	1.5	1.5	1.5	1.5	1.5	1.5
Dimension (WxDxH)	Outline	mm	385×1483×791	385×1483×791	385×1483×791	385×1483×791	385×1483×791	385×1483×791	385×1483×791
	Package	mm	472×1578×883	472×1578×883	472×1578×883	472×1578×883	472×1578×883	472×1578×883	472×1578×883
Net weight/Gross weight	kg		82/104	82/104	82/104	82/104	82/104	82/104	82/104
Loading quantity	40' GP	set	52	52	52	52	52	52	52
	40' HQ	set	65	65	65	65	65	65	65

Model			GMV-ND100PHS/A-T	GMV-ND112PHS/A-T	GMV-ND125PHS/A-T	GMV-ND140PHS/A-T	GMV-ND160PHS/A-T	GMV-ND224PH/A-T	GMV-ND280PH/A-T	
Capacity	Cooling	kW	10.0	11.2	12.5	14.0	16.00	22.4	28.0	
	Heating	kW	11.2	12.5	14.0	16.0	17.00	25.0	31.0	
Power supply	V/Ph/Hz		220~240/1/50 & 208~230/1/60							
Power consumption	W		200	200	220	220	350	800	900	
Airflow volume(H/M/L)	m³/h		1700/1450/1100	1700/1450/1100	2000/1550/1200	2000/1700/1400	2650/2100/1650	4000/3600/3200	4400/4000/3600	
	CFM		1000/853/650	1000/853/650	1175/912/706	1175/1000/824	1560/1236/971	2354/2119/1883	2589/2354/2119	
Rated Current	Cooling	A	1.0	1.0	1.0	1.0	4.0	4.1	4.6	
	Heating	A	1.0	1.0	1.0	1.0	4.0	4.1	4.6	
	Water Heating	A	/	/	/	/	/	/	/	
ESP	Pa		70/0~100			70/0~150	100/50~200	100/50~200		
Sound pressure level(H/M/L)	dB(A)		46/44/42	46/44/42	48/45/42	48/46/44	50/48/46	54/52/49	55/52/50	
Connecting pipe diameter	Liquid	mm	Φ9.52	Φ9.52	Φ9.52	Φ9.52	Φ9.52	Φ9.52	Φ9.52	
	Gas	mm	Φ15.9	Φ15.9	Φ15.9	Φ15.9	Φ19.05	Φ19.05	Φ22.2	
Drain pipe	External dia.	mm	Φ25	Φ25	Φ25	Φ25	Φ30	Φ30		
	Thickness	mm	2.5	2.5	2.5	2.5	2.5	1.5	1.5	
Dimension (WxDxH)	Outline	mm	1229x775x290					1340x750x350	1483x791x385	1686x870x450
	Package	mm	1338x877x305					1423x837x455	1578x883x472	1788x988x580
Net weight/Gross weight	kg		47/54	47/54	47/54	47/54	60/71	82/104	105/140	
Loading	40' GP	set	128	128	128	128	110	52	52	
	40' HQ	set	128	128	128	128	110	65	52	

Model			GMV-ND22PHS/B-T	GMV-ND25PHS/B-T	GMV-ND28PHS/B-T	GMV-ND32PHS/B-T	GMV-ND36PHS/B-T	GMV-ND40PHS/B-T	
Capacity	Cooling	kW	2.2	2.5	2.8	3.2	3.6	4.0	
	Heating	kW	2.5	2.8	3.2	3.6	4.0	4.5	
Power supply	V/Ph/Hz		220~240/1/50 & 208~230/1/60						
Power consumption	W		55	55	55	65	65	85	
Airflow volume(H/M/L)	m³/h		550/480/400	550/480/400	550/480/400	600/500/420	600/500/420	850/700/600	
	CFM		324/282/235	324/282/235	324/282/235	353/294/247	353/294/247	500/412/353	
Rated Current	Cooling	A	0.5	0.5	0.5	0.5	0.5	0.5	
	Heating	A	0.5	0.5	0.5	0.5	0.5	0.5	
	Water Heating	A	/	/	/	/	/	/	
ESP	Pa		60/0~150	60/0~150	60/0~150	60/0~150	60/0~150	60/0~150	
Sound pressure level(H/M/L)	dB(A)		33/30/28	33/30/28	33/30/28	33/31/29	33/31/29	36/34/32	
Connecting pipe diameter	Liquid	mm	Φ6.35	Φ6.35	Φ6.35	Φ6.35	Φ6.35	Φ6.35	
	Gas	mm	Φ9.52	Φ9.52	Φ9.52	Φ12.7	Φ12.7	Φ12.7	
Drain pipe	External dia.	mm	Φ25	Φ25	Φ25	Φ25	Φ25	Φ25	
	Thickness	mm	2.5	2.5	2.5	2.5	2.5	2.5	
Dimension (WxDxH)	Outline	mm	700×700×300	700×700×300	700×700×300	700×700×300	700×700×300	700×700×300	
	Package	mm	897×808×362	897×808×362	897×808×362	897×808×362	897×808×362	897×808×362	
Net weight/Gross weight	kg		32/38	32/38	32/38	32/38	32/38	34/40	
Loading	40' GP	set	168	168	168	168	168	168	
	40' HQ	set	196	196	196	196	196	196	

Model			GMV-NDR20 PH/B1-T	GMV-NDR22 PH/B1-T	GMV-NDR25 PH/B1-T	GMV-NDR28 PH/B1-T	GMV-NDR32 PH/B1-T	GMV-NDR36 PH/B1-T	GMV-NDR45 PH/B1-T
Capacity	Cooling	kW	2	2.2	2.5	2.8	3.2	3.6	4.5
	Heating	kW	2.2	2.5	2.8	3.2	3.6	4	5
Power supply	V/Ph/Hz		208-230/220-240V ~60/50						
Power consumption	W		380	380	380	380	380	380	380
Airflow volume(H/M/L)	m³/h		2625	2625	2625	2625	2625	2625	2625
	CFM		1545	1545	1545	1545	1545	1545	1545
Rated Current	Cooling	A	1.75	1.75	1.75	1.75	1.75	1.75	1.75
	Heating	A	1.75	1.75	1.75	1.75	1.75	1.75	1.75
	Water Heating	A	/	/	/	/	/	/	/
ESP	Pa		25/25~200	25/25~200	25/25~200	25/25~200	25/25~200	25/25~200	25/25~200
Sound pressure level(H/M/L)	dB(A)		46/42/38	46/42/38	46/42/38	46/42/38	46/42/38	46/42/38	46/42/38
Connecting pipe diameter	Liquid	mm	Φ9.52	Φ9.52	Φ9.52	Φ9.52	Φ9.52	Φ9.52	Φ9.52
	Gas	mm	Φ15.9	Φ15.9	Φ15.9	Φ15.9	Φ15.9	Φ15.9	Φ15.9
Drain pipe	External dia.	mm	Φ25	Φ25	Φ25	Φ25	Φ25	Φ25	Φ25
	Thickness	mm	2.5	2.5	2.5	2.5	2.5	2.5	2.5
Dimension (WxDxH)	Outline	mm	1000×700×300	1000×700×300	1000×700×300	1000×700×300	1000×700×300	1000×700×300	1000×700×300
	Package	mm	1205×813×360	1205×813×360	1205×813×360	1205×813×360	1205×813×360	1205×813×360	1205×813×360
Net weight/Gross weight	kg		43/49	43/49	43/49	43/49	43/49	43/49	43/49
Loading quantity	40' GP	set	173	173	173	173	173	173	173
	40' HQ	set	190	190	190	190	190	190	190

Model			GMV-ND45PHS/B-T	GMV-ND50PHS/B-T	GMV-ND56PHS/B-T	GMV-ND63PHS/B-T	GMV-ND71PHS/B-T	GMV-ND80PHS/B-T	
Capacity	Cooling	kW	4.5	5.0	5.6	6.3	7.0	8.0	
	Heating	kW	5.0	5.6	6.3	7.1	8.0	9.0	
Power supply	V/Ph/Hz		220~240/1/50 & 208~230/1/60						
Power consumption	W		85	85	90	90	100	100	
Airflow volume(H/M/L)	m³/h		850/700/600	850/700/600	1000/800/700	1000/800/700	1250/1050/950	1250/1050/950	
	CFM		500/412/353	500/412/353	589/471/412	589/471/412	736/618/559	736/618/559	
Rated Current	Cooling	A	0.5	0.5	0.8	0.8	0.8	0.8	
	Heating	A	0.5	0.5	0.8	0.8	0.8	0.8	
	Water Heating	A	/	/	/	/	/	/	
ESP	Pa		60/0~150	60/0~150	90/0~200	90/0~200	90/0~200	90/0~200	
Sound pressure level(H/M/L)	dB(A)		36/34/32	36/34/32	37/35/33	37/35/33	38/36/34	38/36/34	
Connecting pipe diameter	Liquid	mm	Φ6.35	Φ6.35	Φ9.52	Φ9.52	Φ9.52	Φ9.52	
	Gas	mm	Φ12.7	Φ12.7	Φ15.9	Φ15.9	Φ15.9	Φ15.9	
Drain pipe	External dia.	mm	Φ25	Φ25	Φ25	Φ25	Φ25	Φ25	
	Thickness	mm	2.5	2.5	2.5	2.5	2.5	2.5	
Dimension (WxDxH)	Outline	mm	700×700×300	700×700×300	1000×700×300	1000×700×300	1000×700×300	1000×700×300	
	Package	mm	897×808×362	897×808×362	1205×813×360	1205×813×360	1205×813×360	1205×813×360	
Net weight/Gross weight	kg		34/40	34/40	43/49	43/49	43/49	43/49	
Loading	40' GP	set	168	168	138	138	138	138	
	40' HQ	set</							



Model		GMV-ND90PHS/B-T	GMV-ND100PHS/B-T	GMV-ND112PHS/B-T	GMV-ND125PHS/B-T	GMV-ND140PHS/B-T	GMV-ND160PHS/B-T	
Capacity	Cooling	kW	9.0	10.0	11.2	12.5	14.0	16.0
	Heating	kW	10.0	11.2	12.5	14.0	16.0	18.0
Power supply	V/Ph/Hz		220~240/1/50 & 208~230/1/60					
Power consumption	W		140	140	160	160	220	230
Airflow volume(H/M/L)	m <sup>3</sup> /h		1800/1450/1250	1800/1450/1250	2000/1600/1400	2000/1600/1400	2350/1900/1650	2500/2000/1750
	CFM		1059/853/736	1059/853/736	1177/942/824	1177/942/824	1383/1118/971	1471/1177/1030
Rated Current	Cooling	A	1.1	1.1	1.1	1.1	2.0	2.0
	Heating	A	1.1	1.1	1.1	1.1	2.0	2.0
	Water Heating	A	/	/	/	/	/	/
ESP	Pa		90/0~200	90/0~200	90/0~200	90/0~200	90/0~200	90/0~200
Sound pressure level(H/M/L)	dB(A)		40/37/35	40/37/35	40/38/36	40/38/36	42/39/37	44/41/38
Connecting pipe diameter	Liquid	mm	Φ9.52	Φ9.52	Φ9.52	Φ9.52	Φ9.52	Φ9.52
	Gas	mm	Φ15.9	Φ15.9	Φ15.9	Φ15.9	Φ15.9	Φ19.05
Drain pipe	External dia.	mm	Φ25	Φ25	Φ25	Φ25	Φ25	Φ25
	Thickness	mm	2.5	2.5	2.5	2.5	2.5	2.5
Dimension (WxDxH)	Outline	mm	1400×700×300	1400×700×300	1400×700×300	1400×700×300	1400×700×300	1400×700×300
	Package	mm	1601×813×360	1601×813×360	1601×813×360	1601×813×360	1678×808×365	1678×808×365
Net weight/Gross weight	kg		57/64	57/64	57/64	57/64	58/67	58/67
Loading	40' GP	set	84	84	84	84	84	84
	40' HQ	set	98	98	98	98	98	98

### Low Static Pressure Duct Type Indoor Unit 50/60 Hz

Model		GMV-ND22PLS/A-T	GMV-ND25PLS/A-T	GMV-ND28PLS/A-T	GMV-ND32PLS/A-T	GMV-ND36PLS/A-T	
Capacity	Cooling	kW	2.2	2.5	2.8	3.2	3.6
	Heating	kW	2.5	2.8	3.2	3.6	4.0
Power supply	V/Ph/Hz		220~240/1/50 & 208~230/1/60				
Power consumption	W		35	35	43	43	
Airflow volume(H/M/L)	m <sup>3</sup> /h		450/350/250	450/350/250	450/350/250	550/450/350	550/450/350
	CFM		265/206/147	265/206/147	265/206/147	325/265/206	325/265/206
Rated Current	Cooling	A	0.2	0.2	0.2	0.2	0.2
	Heating	A	0.2	0.2	0.2	0.2	0.2
	Water Heating	A	/	/	/	/	/
ESP	Pa		15/0~30				
Sound pressure level(H/M/L)	dB(A)		31/28/25	31/28/25	31/28/25	32/30/27	32/30/27
Connecting pipe diameter	Liquid	mm	Φ6.35	Φ6.35	Φ6.35	Φ6.35	Φ6.35
	Gas	mm	Φ9.52	Φ9.52	Φ9.52	Φ12.7	Φ12.7
Drain pipe	External dia.	mm	25	25	25	25	25
	Thickness	mm	2.5	2.5	2.5	2.5	2.5
Dimension (WxDxH)	Outline	mm	700 x 615 x 200				
	Package	mm	893x743x305				
Net weight/Gross weight	kg		22/27	22/27	22/27	22/28	22/28
Loading	40' GP	set	192	192	192	192	192
	40' HQ	set	192	192	192	192	192

Model		GMV-ND40PLS/A-T	GMV-ND45PLS/A-T	GMV-ND50PLS/A-T	GMV-ND56PLS/A-T	GMV-ND63PLS/A-T	
Capacity	Cooling	kW	4.0	4.5	5.0	5.6	6.3
	Heating	kW	4.5	5.0	5.6	6.3	7.1
Power supply	V/Ph/Hz		220~240/1/50 & 208~230/1/60				
Power consumption	W		52	52	52	99	99
Airflow volume(H/M/L)	m <sup>3</sup> /h		700/600/450	700/600/450	700/600/450	1000/800/600	1000/800/600
	CFM		410/355/265	410/355/265	410/355/265	590/471/355	590/471/355
Rated Current	Cooling	A	0.3	0.3	0.3	0.5	0.5
	Heating	A	0.3	0.3	0.3	0.5	0.5
	Water Heating	A	/	/	/	/	/
ESP	Pa		15/0~30				
Sound pressure level(H/M/L)	dB(A)		33/31/28	33/31/28	33/31/28	35/33/30	35/33/30
Connecting pipe diameter	Liquid	mm	Φ6.35	Φ6.35	Φ6.35	Φ9.52	Φ9.52
	Gas	mm	Φ12.7	Φ12.7	Φ12.7	Φ15.9	Φ15.9
Drain pipe	External dia.	mm	25	25	25	25	25
	Thickness	mm	2.5	2.5	2.5	2.5	2.5
Dimension (WxDxH)	Outline	mm	900 x 615 x 200		1100 x 615 x 200		
	Package	mm	1123x743x305		1323x743x305		
Net weight/Gross weight	kg		27/33	27/33	27/33	31/38	31/38
Loading	40' GP	set	192	192	192	162	162
	40' HQ	set	192	192	192	162	162

Model		GMV-ND71PLS/A-T	GMV-ND80PLS/A-T	GMV-ND90PLS/A-T	GMV-ND100PLS/A-T	GMV-ND112PLS/A-T	GMV-ND125PLS/A-T	GMV-ND140PLS/A-T	
Capacity	Cooling	kW	7.1	8.0	9.0	10.0	11.2	12.5	14.0
	Heating	kW	8.0	9.0	10.0	11.2	12.5	14.0	16.0
Power supply	V/Ph/Hz		220~240/1/50 & 208~230/1/60						
Power consumption	W		105	140	209	209	209	230	230
Airflow volume(H/M/L)	m <sup>3</sup> /h		1000/800/600	1100/1000/800	1500/1250/950	1500/1350/1000	1700/1500/1100	2000/1500/1150	2000/1500/1150
	CFM		590/471/355	650/590/471	885/736/599	885/795/590	1000/885/650	1175/885/677	1175/885/677
Rated Current	Cooling	A	0.5	0.7	1.0	1.0	1.0	1.1	1.1
	Heating	A	0.5	0.7	1.0	1.0	1.0	1.1	1.1
	Water Heating	A	/	/	/	/	/	/	/
ESP	Pa		30/0~50						
Sound pressure level(H/M/L)	dB(A)		35/33/30	36/34/31	40/36/32	40/36/32	40/36/32	42/40/37	42/40/37
Connecting pipe diameter	Liquid	mm	Φ9.52	Φ9.52	Φ9.52	Φ9.52	Φ9.52	Φ9.52	Φ9.52
	Gas	mm	Φ15.9	Φ15.9	Φ15.9	Φ15.9	Φ15.9	Φ15.9	Φ15.9
Drain pipe	External dia.	mm	25	25	25	25	25	25	25
	Thickness	mm	2.5	2.5	2.5	2.5	2.5	2.5	2.5
Dimension (WxDxH)	Outline	mm	1200 x 655 x 260			1340 x 655 x 260			
	Package	mm	1448x858x315			1591x861x330			
Net weight/Gross weight	kg		40/47	40/47	46/55	46/55	46/55	47/56	47/56
Loading	40' GP	set	96	96	78	78	78	78	78
	40' HQ	set	96	96	78	78	78	78	78

### Slim Ducted Type Indoor Unit 50/60 Hz

Model		GMV-ND22PL/B-T*	GMV-ND25PL/B-T*	GMV-ND28PL/B-T*	GMV-ND32PL/B-T*	GMV-ND36PL/B-T*	
Capacity	Cooling	kW	2.2	2.5	2.8	3.2	3.6
	Heating	kW	2.5	2.8	3.2	3.6	4.0
Power supply	V/Ph/Hz		220~240/1/50 & 208~230/1/60				
Power consumption	W		25	25	30	30	
Airflow volume(H/M/L)	m <sup>3</sup> /h		450/400/320	450/400/320	450/400/320	550/450/340	550/450/340
	CFM		265/235/188	265/235/188	265/235/188	324/265/200	324/265/200
Rated Current	Cooling	A	0.2	0.2	0.2	0.3	0.3
	Heating	A	0.2	0.2	0.2	0.3	0.3
	Water Heating	A	/	/	/	/	/
ESP	Pa		0/15				
Sound pressure level(H/M/L)	dB(A)		30/28/22	30/28/22	30/28/22	31/29/25	31/29/25
Connecting pipe diameter	Liquid	mm	Φ6.35	Φ6.35	Φ6.35	Φ6.35	Φ6.35
	Gas	mm	Φ9.52	Φ9.52	Φ9.52	Φ12.7	Φ12.7
Drain pipe	External dia.	mm	25	25	25	25	25
	Thickness	mm	2.5	2.5	2.5	2.5	2.5
Dimension (WxDxH)	Outline	mm	710x450x200				
	Package	mm	1003x551x285				
Net weight/Gross weight	kg		18.5/22	18.5/22	18.5/22	19.5/23	19.5/23
Loading	40' GP	set	352	352	352	352	352
	40' HQ	set	352	352	352	352	352

Model		GMV-ND40PL/B-T*	GMV-ND45PL/B-T*	GMV-ND50PL/B-T*	GMV-ND56PL/B-T*	GMV-ND63PL/B-T*	GMV-ND72PL/B-T*	
Capacity	Cooling	kW	4.0	4.5	5.0	5.6	6.3	7.2
	Heating	kW	4.5	5.0	5.6	6.3	7.0	8.0
Power supply	V/Ph/Hz		220~240/1/50 & 208~230/1/60					
Power consumption	W		35	35	35	45	45	50
Airflow volume(H/M/L)	m <sup>3</sup> /h		750/660/540	750/660/540	750/660/540	850/700/610	850/700/610	1100/800/640
	CFM		441/388/318	441/388/318	441/388/318	500/412/359	500/412/359	647/471/377
Rated Current	Cooling	A	0.3	0.3	0.3	0.3	0.3	0.5
	Heating	A	0.3	0.3	0.3	0.3	0.3	0.5
	Water Heating	A	/	/	/	/	/	/
ESP	Pa		0/15					
Sound pressure level(H/M/L)	dB(A)		33/30/27	33/30/27	33/30/27	35/33/29	35/33/29	37/34/30
Connecting pipe diameter	Liquid	mm	Φ6.35	Φ6.35	Φ6.35	Φ9.52	Φ9.52	Φ9.52
	Gas	mm	Φ12.7	Φ12.7	Φ12.7	Φ15.9	Φ15.9	Φ15.9
Drain pipe	External dia.	mm	25	25	25	25	25	25
	Thickness	mm	2.5	2.5	2.5	2.5	2.5	2.5
Dimension (WxDxH)	Outline	mm	1010x450x200				1310x450x200	
	Package	mm	1303x551x285				1603x551x285	
Net weight/Gross weight	kg		23.5/28	23.5/28	23.5/28	24.5/29	24.5/29	30.5/36
Loading	40' GP	set	288	288	288	288	288	224
	40' HQ	set	288	288	288	288	288	224

Note:  
\* This series is without water pump.



### 4-way Cassette Indoor Unit 50/60 Hz

Model			GMV-ND28T/A-T	GMV-ND36T/A-T	GMV-ND45T/A-T	GMV-ND50T/A-T	GMV-ND56T/A-T	GMV-ND63T/A-T	GMV-ND71T/A-T	
Capacity	Cooling	kW	2.8	3.6	4.5	5.0	5.6	6.3	7.1	
	Heating	kW	3.2	4.0	5.0	5.6	6.3	7.1	8.0	
Power supply	V/Ph/Hz		220~240/1/50 & 208~230/1/60							
Power consumption	W		48	48	48	50	59	59	68	
Airflow volume(H/M/L)	m <sup>3</sup> /h		750/650/550	750/650/550	750/650/550	830/650/550	1000/900/750	1000/900/750	1180/950/850	
	CFM		440/383/325	440/383/325	440/383/325	490/383/325	590/530/440	590/530/440	695/559/550	
Rated Current	Cooling	A	0.2	0.2	0.2	0.2	0.3	0.3	0.3	
	Heating	A	0.2	0.2	0.2	0.2	0.3	0.3	0.3	
	Water Heating	A	/	/	/	/	/	/	/	
Sound pressure level(H/M/L)	dB(A)		36/34/31	36/34/31	36/34/31	36/34/31	37/35/32	37/35/32	38/36/33	
Connecting pipe diameter	Liquid	mm	Φ6.35	Φ6.35	Φ6.35	Φ6.35	Φ9.52	Φ9.52	Φ9.52	
	Gas	mm	Φ9.52	Φ12.7	Φ12.7	Φ12.7	Φ15.9	Φ15.9	Φ15.9	
Drain pipe	External dia.	mm	25	25	25	25	25	25	25	
	Thickness	mm	2.5	2.5	2.5	2.5	2.5	2.5	2.5	
Main Body	Dimension (WxDxH)	Outline	mm	840x840x190	840x840x190	840x840x190	840x840x190	840x840x240	840x840x240	840x840x240
		Package	mm	963x963x272	963x963x272	963x963x272	963x963x272	963x963x325	963x963x325	963x963x325
	Net weight/Gross weight	kg	22.5/29.5	22.5/29.5	22.5/29.5	22.5/29.5	26.5/34.5	26.5/34.5	26.5/34.5	
Panel	Dimension (WxDxH)	Outline	mm	950x950x65	950x950x65	950x950x65	950x950x65	950x950x65	950x950x65	950x950x65
		Package	mm	1033x1038x133	1033x1038x133	1033x1038x133	1033x1038x133	1033x1038x133	1033x1038x133	1033x1038x133
	Net weight/Gross weight	kg	7/11	7/11	7/11	7/11	7/11	7/11	7/11	
Loading quantity	40'GP	set	167	167	167	167	140	140	140	
	40'HQ	set	171	171	171	171	156	156	156	

Model			GMV-ND80T/A-T	GMV-ND90T/A-T	GMV-ND100T/A-T	GMV-ND112T/A-T	GMV-ND125T/A-T	GMV-ND140T/A-T	GMV-ND160T/A-T	
Capacity	Cooling	kW	8.0	9.0	10.0	11.2	12.5	14.0	16.0	
	Heating	kW	9.0	10.0	11.2	12.5	14.0	16.0	17.5	
Power supply	V/Ph/Hz		220~240/1/50 & 208~230/1/60							
Power consumption	W		68	98	98	110	110	110	130	
Airflow volume(H/M/L)	m <sup>3</sup> /h		1180/950/850	1500/1350/1100	1500/1350/1100	1700/1400/1100	1860/1500/1150	1860/1500/1150	2100/1700/1400	
	CFM		695/559/550	880/795/650	880/795/650	1000/824/650	1095/880/677	1095/880/677	1235/1000/824	
Rated Current	Cooling	A	0.3	0.4	0.4	0.5	0.5	0.5	0.6	
	Heating	A	0.3	0.4	0.4	0.5	0.5	0.5	0.6	
	Water Heating	A	/	/	/	/	/	/	/	
Sound pressure level(H/M/L)	dB(A)		38/36/33	40/37/35	40/37/35	41/38/36	43/41/38	43/41/38	47/44/42	
Connecting pipe diameter	Liquid	mm	Φ9.52	Φ9.52	Φ9.52	Φ9.52	Φ9.52	Φ9.52	Φ9.52	
	Gas	mm	Φ15.9	Φ15.9	Φ15.9	Φ15.9	Φ15.9	Φ15.9	Φ19.05	
Drain pipe	External dia.	mm	25	25	25	25	25	25	25	
	Thickness	mm	2.5	2.5	2.5	2.5	2.5	2.5	2.5	
Main Body	Dimension (WxDxH)	Outline	mm	840x840x240	840x840x320	840x840x320	840x840x320	840x840x320	840x840x320	910x910x293
		Package	mm	963x963x325	963x963x409	963x963x409	963x963x409	963x963x409	963x963x409	1023x993x375
	Net weight/Gross weight	kg	26.5/34.5	32.5/40.0	32.5/40.0	32.5/40.0	32.5/40.0	32.5/40.0	46.5/56.5	
Panel	Dimension (WxDxH)	Outline	mm	950x950x65	950x950x65	950x950x65	950x950x65	950x950x65	950x950x65	1040x1040x65
		Package	mm	1033x1038x133	1033x1038x133	1033x1038x133	1033x1038x133	1033x1038x133	1033x1038x133	1137x1137x140
	Net weight/Gross weight	kg	7/11	7/11	7/11	7/11	7/11	7/11	7.5/11.5	
Loading quantity	40'GP	set	140	104	104	104	104	104	144	
	40'HQ	set	156	119	119	119	119	119	144	

Model			GMV-ND28T /A1-T	GMV-ND36T /A1-T	GMV-ND40T /A1-T	GMV-ND45T /A1-T	GMV-ND50T /A1-T	GMV-ND56T /A1-T	GMV-ND63T /A1-T	GMV-ND71T /A1-T	GMV-ND80T /A1-T
Capacity	Cooling	kW	2.8	3.6	4	4.5	5	5.6	6.3	7.1	8
	Heating	kW	3.2	4	4.5	5	5.6	6.3	7.1	8	9
Power supply	V/Ph/Hz		208-230/220-240V~60/50								
Power consumption	W		130	130	130	150	250	250	250	250	250
Airflow volume (H/M/L)	m <sup>3</sup> /h		1650	1650	1650	2000	2000	2880	2880	2880	2880
	CFM		971	971	971	1177	1177	1694	1694	1694	1694
Rated Current	Cooling	A	0.59	0.59	0.59	0.68	0.68	1.3	1.3	1.3	1.3
	Heating	A	0.59	0.59	0.59	0.68	0.68	1.3	1.3	1.3	1.3
Sound pressure level(H/M/L)	dB(A)		43/41/38	43/41/38	43/41/38	47/44/42	47/44/42	49/46/44	49/46/44	49/46/44	49/46/44
Connecting pipe diameter	Liquid	mm	Φ9.52	Φ9.52	Φ9.52	Φ9.52	Φ9.52	Φ9.52	Φ9.52	Φ9.52	Φ9.52
	Gas	mm	Φ15.9	Φ15.9	Φ15.9	Φ15.9	Φ15.9	Φ15.9	Φ15.9	Φ15.9	Φ19.05
Drain pipe	External dia.	mm	Φ25	Φ25	Φ25	Φ25	Φ25	Φ25	Φ25	Φ25	Φ25
	Thickness	mm	2.5	2.5	2.5	2.5	2.5	2.5	2.5	2.5	2.5
Main body Dimension (WxDxH)	Outline	mm	840x840x240	840x840x240	840x840x240	840x840x320	840x840x320	910x910x293	910x910x293	910x910x293	910x910x293
	Package	mm	963x963x325	963x963x325	963x963x325	963x963x409	963x963x409	1023x993x375	1023x993x375	1023x993x375	1023x993x375
	Net weight/Gross weight	kg	26.5/34.5	26.5/34.5	26.5/34.5	32.5/40.0	32.5/40.0	46.5/56.5	46.5/56.5	46.5/56.5	46.5/56.5
Panel Dimension (WxDxH)	Outline	mm	950x950x65	950x950x65	950x950x65	950x950x65	950x950x65	1040x1040x65	1040x1040x65	1040x1040x65	1040x1040x65
	Package	mm	1033x1038x133	1033x1038x133	1033x1038x133	1033x1038x133	1033x1038x133	1137x1137x140	1137x1137x140	1137x1137x140	1137x1137x140
	Net weight/Gross weight	kg	7/11	7/11	7/11	7/11	7/11	8/11.5	8/11.5	8/11.5	8/11.5
Loading quantity	40'GP	set	140	140	140	104	104	144	144	144	144
	40'HQ	set	156	156	156	119	119	144	144	144	144

### Compact 4-way Cassette Indoor Unit 50/60 Hz

Model			GMV-ND22T/B-T	GMV-ND28T/B-T	GMV-ND36T/B-T	GMV-ND45T/B-T	GMV-ND50T/B-T	GMV-ND56T/B-T	
Capacity	Cooling	kW	2.2	2.8	3.6	4.5	5	5.6	
	Heating	kW	2.5	3.2	4	5	5.6	6.3	
Power supply	V/Ph/Hz		220~240/1/50 & 208~230/1/60						
Power consumption	W		35	35	35	45	45	45	
Airflow volume(H/M/L)	m <sup>3</sup> /h		600/500/400	600/500/400	600/500/400	700/600/500	700/600/500	700/600/500	
	CFM		355/295/235	355/295/235	355/295/235	410/355/295	410/355/295	410/355/295	
Rated Current	Cooling	A	0.4	0.4	0.4	0.5	0.5	0.5	
	Heating	A	0.4	0.4	0.4	0.5	0.5	0.5	
	Water Heating	A	/	/	/	/	/	/	
Sound pressure level(H/M/L)	dB(A)		46/39/35	46/39/35	46/39/35	47/43/38	47/43/38	47/43/38	
Connecting pipe diameter	Liquid	mm	Φ6.35	Φ6.35	Φ6.35	Φ6.35	Φ6.35	Φ9.52	
	Gas	mm	Φ9.52	Φ9.52	Φ12.7	Φ12.7	Φ12.7	Φ15.9	
Drain pipe	External dia.	mm	25	25	25	25	25	25	
	Thickness	mm	2.5	2.5	2.5	2.5	2.5	2.5	
Main Body	Dimension (WxDxH)	Outline	mm	596x596x240	596x596x240	596x596x240	596x596x240	596x596x240	596x596x240
		Package	mm	778x738x300	778x738x300	778x738x300	778x738x300	778x738x300	778x738x300
	Net weight/Gross weight	kg	20.5/25.5	20.5/25.5	20.5/25.5	20.5/25.5	20.5/25.5	20.5/25.5	
Panel	Dimension (WxDxH)	Outline	mm	650x650x50	650x650x50	650x650x50	650x650x50	650x650x50	650x650x50
		Package	mm	763x763x105	763x763x105	763x763x105	763x763x105	763x763x105	763x763x105
	Net weight/Gross weight	kg	3.5/5.0	3.5/5.0	3.5/5.0	3.5/5.0	3.5/5.0	3.5/5.0	
Loading quantity	40'GP	set	267	267	267	267	267	267	
	40'HQ	set	288	288	288	288	288	288	

### 2-way Cassette Indoor Unit 50/60 Hz

Model			GMV-ND28TS/A-T	GMV-ND36TS/A-T	GMV-ND45TS/A-T	GMV-ND50TS/A-T	GMV-ND56TS/A-T	GMV-ND63TS/A-T	GMV-ND71TS/A-T
Capacity	Cooling	kW	2.8	3.6	4.5	5.0	5.6	6.3	7.1
	Heating	kW	3.2	4.0	5.0	5.6	6.3	7.1	8.0
Power supply	V/Ph/Hz		220~240/1/50 & 208~230/1/60						
Power consumption	W		55.0	55.0	55.0	103.0	103.0	103.0	103.0
Airflow volume(H/M/L)	m <sup>3</sup> /h		830/660/580	830/660/580	830/660/580	830/660/580	1100/900/750	1100/900/750	1100/900/750
	CFM		490/388/341	490/388/341	490/388/341	490/388/341	650/530/441	650/530/441	650/530/441
Rated Current	Cooling	A	0.3	0.3	0.3	0.3	0.7	0.7	0.7
	Heating	A	0.3	0.3	0.3	0.3	0.7	0.7	0.7
	Water Heating	A	/	/	/	/	/	/	/
Sound pressure level(H/M/L)	dB(A)		35/32/29	35/32/29	35/32/29	35/32/29	39/36/33	39/36/33	39/36/33
Connecting pipe diameter	Liquid	mm	Φ6.35	Φ6.35	Φ6.35	Φ6.35	Φ9.52	Φ9.52	Φ9.52
	Gas	mm	Φ9.52	Φ12.7	Φ12.7	Φ12.7	Φ15.9	Φ15.9	Φ15.9
Drain pipe	External dia.	mm	25	25	25	25	25	25	25
	Thickness	mm	2.5	2.5	2.5	2.5	2.5	2.5	2.5
Main Body	Dimension (WxDxH)	Outline	mm	1200x520x315	1200x520x315	1200x520x315	120		



## Wall-mounted Type Indoor Unit 50 Hz

Model			GMV-N22G/A3A-K *	GMV-N28G/A3A-K *	GMV-N36G/A3A-K *	GMV-N45G/A3A-K *	GMV-N50G/A3A-K *	GMV-N56G/A3A-K *	GMV-N63G/A3A-K *	GMV-N71G/A3A-K *	
Capacity	Cooling	kW	2.2	2.8	3.6	4.5	5.0	5.6	6.3	7.1	
	Heating	kW	2.5	3.2	4.0	5.0	5.8	6.3	7.0	7.5	
Power supply	V/Ph/Hz		220-240/1/50								
Power consumption	W		50	50	60	60	60	70	70	70	
Airflow volume(H/M/L)	m³/h		500/420/350	500/420/350	630/550/480	630/550/480	630/550/480	750/600/500	750/600/500	750/600/500	
	CFM		294/247/206	294/247/206	371/324/282	371/324/282	371/324/282	441/353/294	441/353/294	441/353/294	
Rated Current	Cooling	A	0.2	0.2	0.31	0.31	0.31	0.31	0.31	0.31	
	Heating	A	0.2	0.2	0.31	0.31	0.31	0.31	0.31	0.31	
	Water Heating	A	/	/	/	/	/	/	/	/	
Sound pressure level(H/M/L)	dB(A)		38/34/30	38/34/30	44/41/38	44/41/38	44/41/38	44/41/38	44/41/38	44/41/38	
Connecting pipe diameter	Liquid	mm	Φ6.35	Φ6.35	Φ6.35	Φ6.35	Φ6.35	Φ9.52	Φ9.52	Φ9.52	
	Gas	mm	Φ9.52	Φ9.52	Φ12.7	Φ12.7	Φ12.7	Φ15.9	Φ15.9	Φ15.9	
Drain pipe	External dia.	mm	Φ20	Φ20	Φ20	Φ20	Φ20	Φ30	Φ30	Φ30	
	Thickness	mm	1.5	1.5	1.5	1.5	1.5	1.5	1.5	1.5	
Dimension (WxDxH)	Outline	mm	843x180x275			940x200x298			1008x221x319		
	Package	mm	973x258x370			1068x288x395			1131x398x328		
Net weight/Gross weight	kg		10/12.5	10/12.5	12.5/15.5	12.5/15.5	12.5/15.5	15/18.5	15/18.5	15/18.5	
Loading	40' GP	set	702	702	557	557	557	441	441	441	
	40' HQ	set	819	819	624	624	624	503	503	503	

Note:  
\* This series is without water pump.

## Fresh Air Processing Indoor Unit 50/60 Hz

Model			GMV-NDX125P/A-T *	GMV-NDX140P/A-T *	GMV-NDX224P/A-T *	GMV-NDX250P/A-T *	GMV-NDX280P/A-T *	GMV-NX450P/A(X4.0)-M *
Capacity	Cooling	kW	12.5	14.0	22.4	25.0	28.0	45
	Heating	kW	10.5	10.0	16.0	20.0	20.0	32
Power supply	V/Ph/Hz		220-240V/1/50 & 208-230/1/60					
Power consumption	W		350	350	760	860	860	1240
Airflow volume(H/M/L)	m³/h		1200/1000~2000	1200	2000/1500~3000	2500/2000~3500	2500/2000~3500	4000
	CFM		/	705	1177/833~1766	/	1471/1177~2060	2355
Rated Current	Cooling	A	2	1.5	4.3	4.9	4.9	2.22
	Heating	A	2	1.5	4.3	4.9	4.9	2.22
	Water Heating	A	/	/	/	/	/	/
ESP	Pa		150/50~200	150/50~200	200/50~270	200/50~300	200/50~280	200
Sound pressure level(H/M/L)	dB(A)		40~50	40~50	45~54	47~54	47~54	58
Connecting pipe diameter	Liquid	mm	Φ9.52	Φ9.52	Φ9.52	Φ6.35	Φ9.52	Φ12.7
	Gas	mm	Φ15.9	Φ15.9	Φ19.05	Φ22.2	Φ22.2	Φ28.6
Drain pipe	External dia.	mm	Φ25	Φ25	Φ30	Φ30	Φ30	Φ33
	Thickness	mm	2.5	2.5	1.5	1.5	1.5	3.0
Dimension (WxDxH)	Outline	mm	1400×700×300	1400×700×300	1483×791×385	1483×791×385	1483×791×385	1700x1100x650
	Package	mm	1601×813×365	1601×813×365	1578×883×472	1578×883×472	1578×883×472	1890x1460x835
Net weight/Gross weight	kg		54/61	54/61	82/104	82/104	82/104	208/266
Loading	40' GP	set	84.0	84.0	52	52	52	16.0
	40' HQ	set	98.0	98.0	65	65	65	16.0

Note: \* This series can be matched with GMV5E(Top discharge outdoor unit)only.

## 50/60 Hz

Model			GMV-ND22G/A3A-T	GMV-ND28G/A3A-T	GMV-ND36G/A3A-T	GMV-ND45G/A3A-T	GMV-ND50G/A3A-T
Capacity	Cooling	kW	2.2	2.8	3.6	4.5	5
	Heating	kW	2.5	3.2	4	5	5.8
Power supply	V/PH/Hz		220-240/1/50 & 208-230/1/60				
Power consumption	W		20	20	30	30	30
Rated current	Cooling	A	0.1	0.1	0.16	0.16	0.16
	Heating	A	0.1	0.1	0.16	0.16	0.16
	Water heating	A	/	/	/	/	/
Sound pressure level	dB (A)		38	38	44	44	44
Connecting pipe diameter	Liquid	mm	Φ6.35	Φ6.35	Φ6.35	Φ6.35	Φ6.35
	Gas	mm	Φ9.52	Φ9.52	Φ12.7	Φ12.7	Φ12.7
Drain pipe	External dia.	mm	Φ20	Φ20	Φ20	Φ20	Φ20
	Thickness	mm	1.5	1.5	1.5	1.5	1.5
Dimension (WxDxH)	Outline	mm	843×180×275	843×180×275	940×200×298	940×200×298	940×200×298
	Package	mm	970×255×355	970×255×355	1065×285×380	1065×285×380	1065×285×380
Net weight/gross weight	Kg		10	10	12.5	12.5	12.5
Loading	40'GP	Set	702	702	557	557	557
	40'HP	Set	819	819	624	624	624

## Console Indoor Unit 50/60 Hz

Model			GMV-ND22C/A-T	GMV-ND28C/A-T	GMV-ND36C/A-T	GMV-ND45C/A-T	GMV-ND50C/A-T
Capacity	Cooling	kW	2.2	2.8	3.6	4.5	5.0
	Heating	kW	2.5	3.2	4.0	5.0	5.5
Power supply	V/Ph/Hz		220-240/1/50 & 208-230/1/60				
Power consumption	W		15	15	20	40	40
Airflow volume(H/M/L)	m³/h		400/320/270	400/320/270	480/400/310	680/600/500	680/600/500
	CFM		235/188/159	235/188/159	282/235/182	400/353/294	400/353/294
Rated Current	Cooling	A	0.17	0.17	0.25	0.4	0.4
	Heating	A	0.17	0.17	0.25	0.4	0.4
	Water Heating	A	/	/	/	/	/
ESP	Pa		0	0	0	0	0
Sound pressure level(H/M/L)	dB(A)		38/33/27	38/33/27	40/37/32	46/43/39	46/43/39
Connecting pipe diameter	Liquid	mm	6.35	6.35	6.35	6.35	6.35
	Gas	mm	9.52	9.52	9.52	12.7	12.7
Drain pipe	External dia.	mm	28	28	28	28	28
	Thickness	mm	1	1	1	1	1
Dimension (WxDxH)	Outline	mm	700/215/600	700/215/600	700/215/600	700/215/600	700/215/600
	Package	mm	788x283x777	788x283x777	788x283x777	788x283x777	788x283x777
Net weight/Gross weight	kg		16/19	16/19	16/19	16/19	16/19
Loading	40' GP	set	348	348	348	348	348
	40' HQ	set	348	348	348	348	348

Model			GMV-ND56G/A3A-T	GMV-ND63G/A3A-T	GMV-ND71G/A3A-T	GMV-ND80G/A3A-T	GMV-ND90G/A3A-T	GMV-ND100G/A3A-T
Capacity	Cooling	kW	5.6	6.3	7.1	8	9	9.5
	Heating	kW	6.3	7	7.5	9	10	10.5
Power supply	V/PH/Hz		220-240/1/50 & 208-230/1/60					
Power consumption	W		40	40	40	80	80	100
Rated current	Cooling	A	0.17	0.17	0.17	0.41	0.41	0.41
	Heating	A	0.17	0.17	0.17	0.41	0.41	0.41
	Water heating	A	/	/	/	/	/	/
Sound pressure level	dB (A)		44	44	44	49	49	52
Connecting pipe diameter	Liquid	mm	Φ9.52	Φ9.52	Φ9.52	Φ9.52	Φ9.52	Φ9.52
	Gas	mm	Φ15.87	Φ15.87	Φ15.87	Φ15.87	Φ15.87	Φ15.87
Drain pipe	External dia.	mm	Φ30	Φ30	Φ30	Φ30	Φ30	Φ30
	Thickness	mm	1.5	1.5	1.5	1.5	1.5	1.5
Dimension (WxDxH)	Outline	mm	1008×221×319	1008×221×319	1008×221×319	1350×258×326	1350×258×326	1350×258×326
	Package	mm	1128×313×395	1128×313×395	1128×313×395	1493×343×418	1493×343×418	1493×343×418
Net weight/gross weight	Kg		15	15	15	18.5	18.5	
Loading	40'GP	Set	441	441	441	228	228	
	40'HP	Set	503	503	503	266	266	



## Floor Ceiling Type Indoor Unit 50/60 Hz

Model			GMV-ND28ZD/A-T	GMV-ND36ZD/A-T	GMV-ND50ZD/A-T	GMV-ND56ZD/A-T	GMV-ND63ZD/A-T	
Capacity	Cooling	kW	2.8	3.6	5.0	5.6	6.3	
	Heating	kW	3.2	4.0	5.6	6.3	7.1	
Power supply	V/Ph/Hz		220~240/1/50 & 208~230/1/60					
Power consumption	W		40	40	50	50	75	
Airflow volume(H/M/L)	m³/h		650/580/500	650/580/500	950/850/700	950/850/700	1400/1150/1000	
	CFM		380/341/294	380/341/294	560/500/410	560/500/410	825/677/590	
Rated Current	Cooling	A	0.3	0.3	0.4	0.4	0.6	
	Heating	A	0.3	0.3	0.4	0.4	0.6	
	Water Heating	A	/	/	/	/	/	
Sound pressure level(H/M/L)	dB(A)		36/34/32	36/34/32	42/38/33	42/38/33	44/42/39	
Connecting pipe diameter	Liquid	mm	Φ6.35	Φ6.35	Φ6.35	Φ6.35	Φ9.52	
	Gas	mm	Φ9.52	Φ12.7	Φ12.7	Φ15.9	Φ15.9	
Drain pipe	External dia.	mm	Φ17	Φ17	Φ17	Φ17	Φ17	
	Thickness	mm	1.75	1.75	1.75	1.75	1.75	
Dimension (WxDxH)	Outline	mm	1220x700x225				1420x700x245	
	Package	mm	1343x823x315				1548x828x345	
Net weight/Gross weight	kg		40/49	40/49	40/49	40/49	50/58	
Loading	40' GP	set	145	145	145	145	90	
	40' HQ	set	158	158	158	158	98	

Model			GMV-ND71ZD/A-T	GMV-ND90ZD/A-T	GMV-ND112ZD/A-T	GMV-ND125ZD/A-T	GMV-ND140ZD/A-T	GMV-ND160ZD/A-T
Capacity	Cooling	kW	7.1	9.0	11.2	12.5	14.0	16.0
	Heating	kW	8.0	10.0	12.5	14.0	16.0	18.0
Power supply	V/Ph/Hz		220~240/1/50 & 208~230/1/60					
Power consumption	W		75	140	160	160	160	200
Airflow volume(H/M/L)	m³/h		1400/1150/1000	1600/1400/1200	2000/1800/1450	2000/1800/1450	2000/1800/1450	2300/2100/1900
	CFM		825/677/590	940/824/706	1175/1059/853	1175/1059/853	1175/1059/853	1354/1236/1119
Rated Current	Cooling	A	0.6	1.1	1.4	1.4	1.4	1.9
	Heating	A	0.6	1.1	1.4	1.4	1.4	1.9
	Water Heating	A	/	/	/	/	/	/
Sound pressure level(H/M/L)	dB(A)		44/42/39	50/47/43	51/46/42	52/49/45	52/49/45	52/49/45
Connecting pipe diameter	Liquid	mm	Φ9.52	Φ9.52	Φ9.52	Φ9.52	Φ9.52	Φ9.52
	Gas	mm	Φ15.9	Φ15.9	Φ15.9	Φ15.9	Φ15.9	Φ19.05
Drain pipe	External dia.	mm	Φ17	Φ17	Φ17	Φ17	Φ17	Φ17
	Thickness	mm	1.75	1.75	1.75	1.75	1.75	1.75
Dimension (WxDxH)	Outline	mm	1420x700x245		1700x700x245			
	Package	mm	1548x828x345		1828x828x345			
Net weight/Gross weight	kg		50/58	50/58	60/68	60/68	60/68	60/68
Loading	40' GP	set	90	90	84	84	84	84
	40' HQ	set	98	98	98	98	98	98

## Concealed Floor Standing Type 50/60 Hz

Model			GMV-ND22ZA/A-T	GMV-ND28ZA/A-T	GMV-ND36ZA/A-T	GMV-ND45ZA/A-T	GMV-ND56ZA/A-T	GMV-ND63ZA/A-T	GMV-ND71ZA/A-T
Capacity	Cooling	kW	2.2	2.8	3.6	4.5	5.6	6.3	7.1
	Heating	kW	2.5	3.2	4	5	6.3	7.1	8
Power supply	V/Ph/Hz		220-240V~50Hz/208-230V~60Hz						
Power consumption	W		35	35	43	45	80	80	90
Airflow volume(H/M/L)	m³/h		450/350/250	450/350/250	550/450/350	650/500/400	900/750/600	900/750/600	1100/900/700
	CFM		265/206/147	265/206/147	324/265/206	383/294/235	530/441/353	530/441/353	647/530/412
Rated Current	Cooling	A	0.18	0.18	0.22	0.23	0.41	0.41	0.46
	Heating	A	0.18	0.18	0.22	0.23	0.41	0.41	0.46
ESP	Pa		10.0~40	10.0~40	10.0~40	15.0~60	15.0~60	15.0~60	15.0~60
Sound pressure level(H/M/L)	dB(A)		30/28/25	30/28/25	33/31/28	33/31/28	35/33/30	35/33/30	37/35/33
Connecting pipe diameter	Liquid	mm	Φ6.35	Φ6.35	Φ6.35	Φ6.35	Φ9.52	Φ9.52	Φ9.52
	Gas	mm	Φ9.52	Φ9.52	Φ12.7	Φ12.7	Φ15.9	Φ15.9	Φ15.9
Drain pipe	External dia.	mm	Φ25	Φ25	Φ25	Φ25	Φ25	Φ25	Φ25
	Thickness	mm	2.5	2.5	2.5	2.5	2.5	2.5	2.5
Dimension (WxDxH)	Outline	mm	700×615×200	700×615×200	700×615×200	900×615×200	1100×615×200	1100×615×200	1100×615×200
	Package	mm	893×743×305	893×743×305	893×743×305	1123×743×305	1323×743×305	1323×743×305	1323×743×305
Net weight/Gross weight	kg		23/30	23/30	23/30	27/36	32/41	32/41	32/41
Loading quantity	40'GP	set	192	192	192	192	162	162	162
	40'HQ	set	192	192	192	192	162	162	162

\*Note: This product model is under development. Please confirm the final specifications with sales representatives.

## Floor Standing Type 50/60 Hz

Model			GMV-ND100L/A-T	GMV-ND140L/A-T
Capacity	Cooling	kW	10	14
	Heating	kW	11	15
Power supply	V/Ph/Hz		220-240/1/50 & 208-230/1/60	
Power consumption	W		185	185
Airflow volume(H/M/L)	m³/h		1850/1600/1400	1850/1600/1400
	CFM		1089/942/824	1089/942/824
Rated Current	Cooling	A	1.5	1.5
	Heating	A	1.5	1.5
	Water Heating	A	/	/
ESP	Pa		0	0
Sound pressure level(H/M/L)	dB(A)		50/48/46	50/48/46
Connecting pipe diameter	Liquid	mm	Φ9.52	Φ9.52
	Gas	mm	Φ15.9	Φ15.9
Drain pipe	External dia.	mm	31	31
	Thickness	mm	4.5	4.5
Dimension (WxDxH)	Outline	mm	1870x580x400	
	Package	mm	2083x738x545	
Net weight/Gross weight	kg		54/74	57/77
Loading	40' GP	set	67	67
	40' HQ	set	67	67

## AHU KIT 50/60 Hz

Model			GMV-N36U/A-T	GMV-N71U/A-T	GMV-N140U/A-T	GMV-N280U/A-T	GMV-N560U/A-T												
Defaulted capacity of ex-factory	Capacity		36	71	140	280	560												
	Cooling	kW	3.6	7.1	14.0	28.0	56.0												
	Heating	kW	4.0	8.0	16.0	31.5	63.0												
Adjustable capacity	Capacity		28	36	45	56	71	90	112	140	224	280	335	400	450	504	560	840	
	Cooling	kW	2.8	3.6	4.5	5.6	7.1	9.0	11.2	14.0	22.4	28.0	33.5	40.0	45.0	50.4	56.0	84.0	
	Heating	kW	3.2	4.0	5.0	6.3	8.0	10.0	12.5	16.0	25.0	31.5	37.5	45.0	50.0	56.5	63.0	94.5	
Power input	W		5.0																
Power supply	V/Ph/Hz		220/1/50																
Size of connection pipe	AHU-KIT	mm	Φ6.35			Φ9.52			Φ9.52			Φ9.52			Φ15.9				
	Air handling	Liquid pipe	mm	Φ6.35	Φ6.35	Φ6.35	Φ9.52	Φ9.52	Φ9.52	Φ9.52	Φ9.52	Φ9.52	Φ9.52	Φ12.7	Φ12.7	Φ12.7	Φ15.9	Φ15.9	Φ19.05
	Gas pipe	mm	Φ9.52	Φ12.7	Φ12.7	Φ15.9	Φ15.9	Φ15.9	Φ15.9	Φ15.9	Φ19.05	Φ22.2	Φ25.4	Φ25.4	Φ28.6	Φ28.6	Φ28.6	Φ31.8	
	Connection method	Braze Connection																	
Outline dimension (W×D×H)	EXV box	mm	203×326×85			203×326×85			203×326×85			203×326×85			246×500×120				
	Control box	mm	334×284×111			334×284×111			334×284×111			334×284×111			334×284×111				
Packing size	mm		539×461×247			539×461×247			539×461×247			539×461×247			759×645×180				
Net weight/Gross weight	kg		8.6/11.5			8.6/11.5			8.6/11.5			8.6/11.5			11.8/15.5				
	40'GP	set	981			981			981			981			702				
Loading	40'HQ	set	1090			1090			1090			1090			756				

Note:

Gree reserves the right to modify the specifications without prior notice. Please confirm the final specifications with sales representatives.



# Control System



## Smart Model Selection Software and Debugging Software

### Model Selection Software

Gree multi VRF selection software is a kind of advanced computer program for selecting models automatically in sales and project bidding. It integrates multi VRF selection logic and computer software to provide a user-friendly interactive interface, which is able to automatically recommend suitable models to user according to ambient condition of project and user's demand.

### New Project Setting and Project Design Conditions

After setting up a new model selection project, input the information of project, customer and designer, and select the function type, power supply, design conditions and other information of outdoor unit.

Project Setting

Project Design Conditions

Confirmation



## Model Selection of Indoor Unit and Outdoor Unit

After selecting room type, the software will recommend the suitable indoor unit series automatically. You can also select indoor unit series manually. After inputting the room area or the required air conditioning load, elbows, drop from ODU, etc., the software will recommend the suitable indoor unit model automatically. Select branch and then input its piping length, drop from ODU and other information to connect the branches with indoor unit and outdoor unit. Select the outdoor unit series and the software will recommend the suitable outdoor unit model automatically.

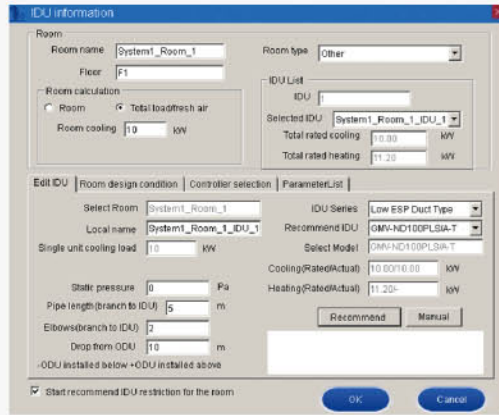

Select IDU

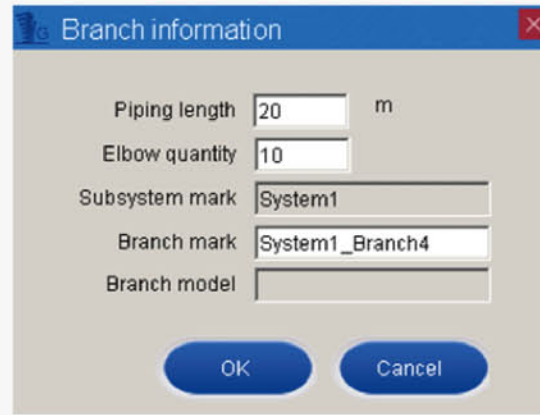

Edit Brand Information

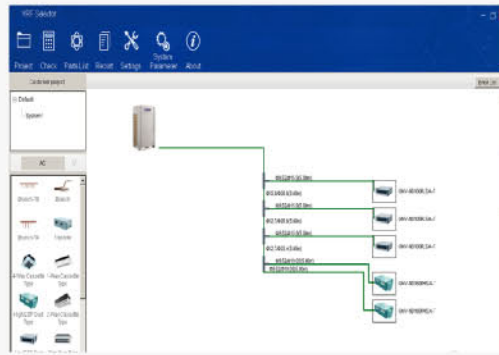

Connection IDU and ODU

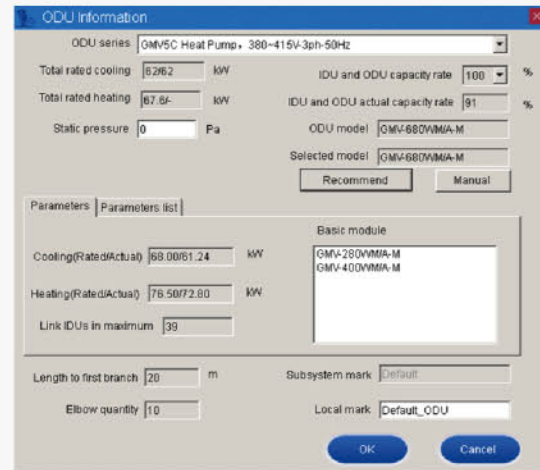

Select ODU

## Check

After finishing the model selection of indoor unit and outdoor, select the check method to check each system in the project and adjust IDU and ODU models.

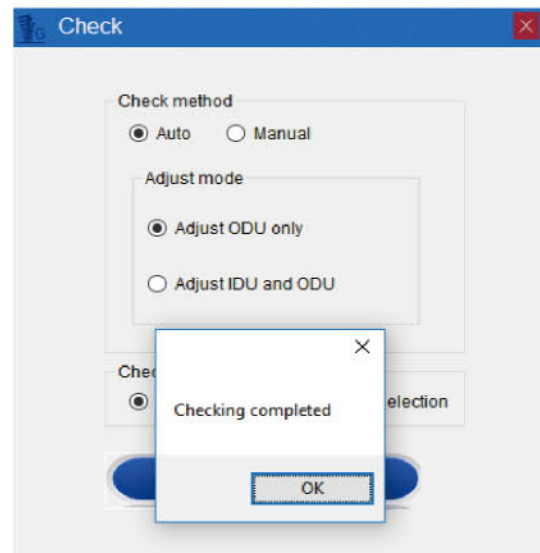

Check

## Electric Configuration and Unit Configuration

After checking, the electric configuration of indoor unit and outdoor unit shall be confirmed. During model selection, metric unit or British unit can be set.

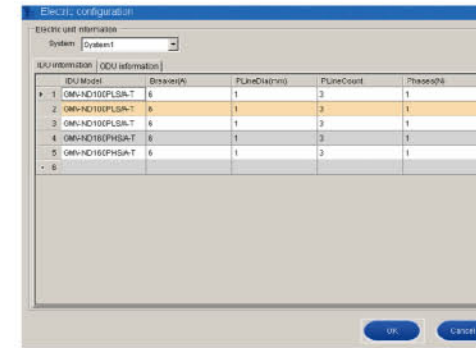

Confirm Electric Configuration

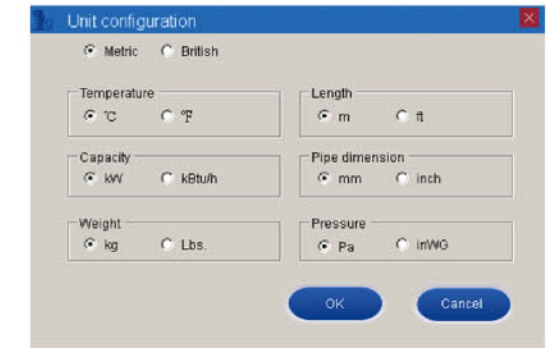

Unit Configuration

## Output Report

After finishing the project settings, the report can be output in excel or CAD format.

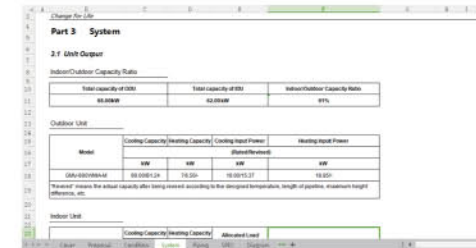

Report in Excel Format

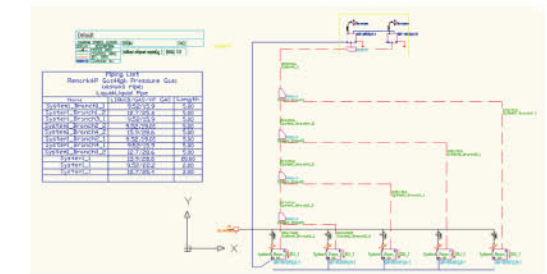

Report in CAD Format

## Intelligent Debugging Software

GMV5E offers an intelligent debugging software to the end-users for faster construction needs.

## Monitoring Functions

- Fully control the operation status of each device of the system;
- Hover the mouse over the parameter to display its remarks.
- The online devices will be displayed in a tree structure;
- Display the information of air conditioner in divided regions;
- Each display region can be moved or concealed;
- Display updated status of units in real time;

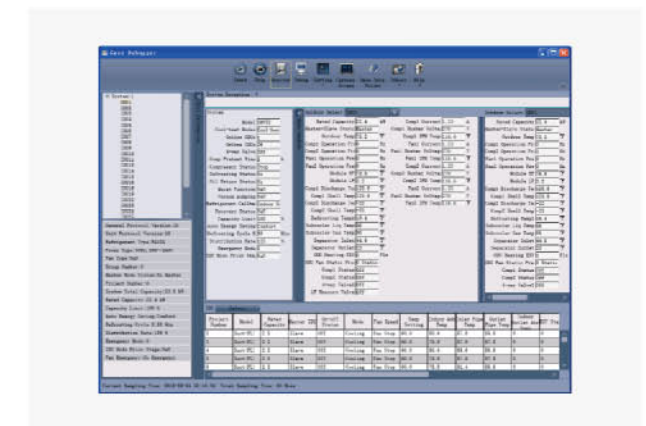



### Control Functions

- Control the operation of unit as you like;
- Comprehensive control of outdoor unit, indoor unit, water tank, hydro box, etc.;
- Real-time display of current status or status after being controlled;
- Both single control and group control are available.

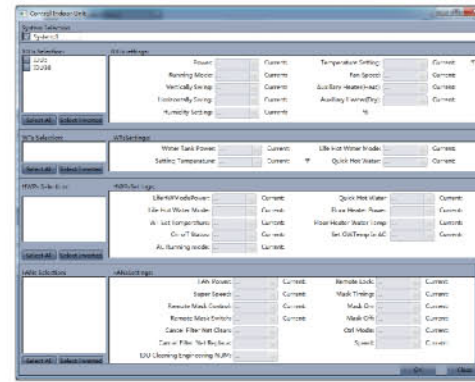

### Project Debugging Functions

- One-click and automatic project debugging;
- Project debugging is arranged step by step from left to right;
- Manual intervention and skipping of some debugging phases are available.
- Green icons will be displayed for the items finishing debugging; red icons will be displayed for the items having debug exception; light yellow icons display debugging information;



### Auto Data-Saving Function

Data will be saved automatically. Database saving path can be changed or data document can be generated repeatedly.

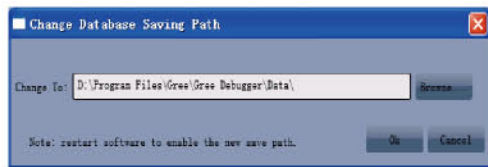

Step 1: Change Database Saving Path

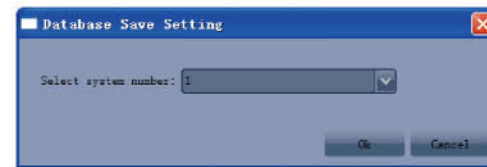

Step 2: Database Save Setting

### USB Data Converter

Users can use USB data converter to freely convert CAN/HBS/RS485 data into USB data, achieving data interchange between computer and air conditioner.

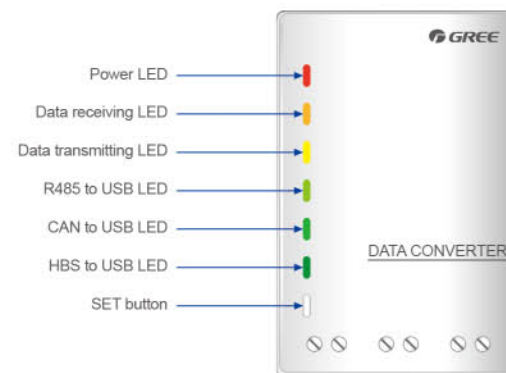

### Auto Direction of Connection Way

The wiring diagram will direct connection way automatically, so that the user can get the connection way quickly.

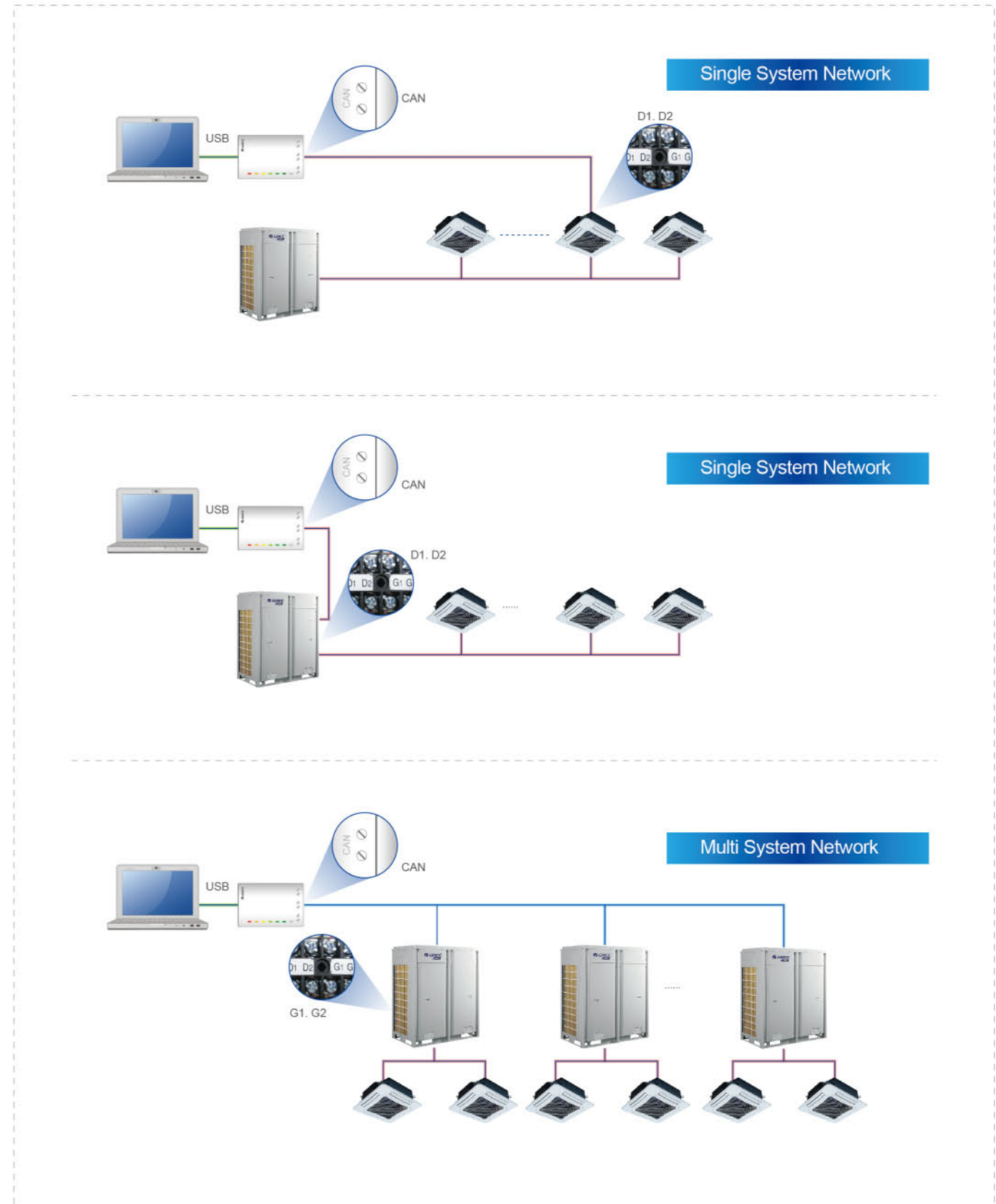



# Multiple Intelligent Remote Control Management

Gree GMV5E provides multiple intelligent controls in order to satisfy all demands. It can control both a room and a building at the same time.

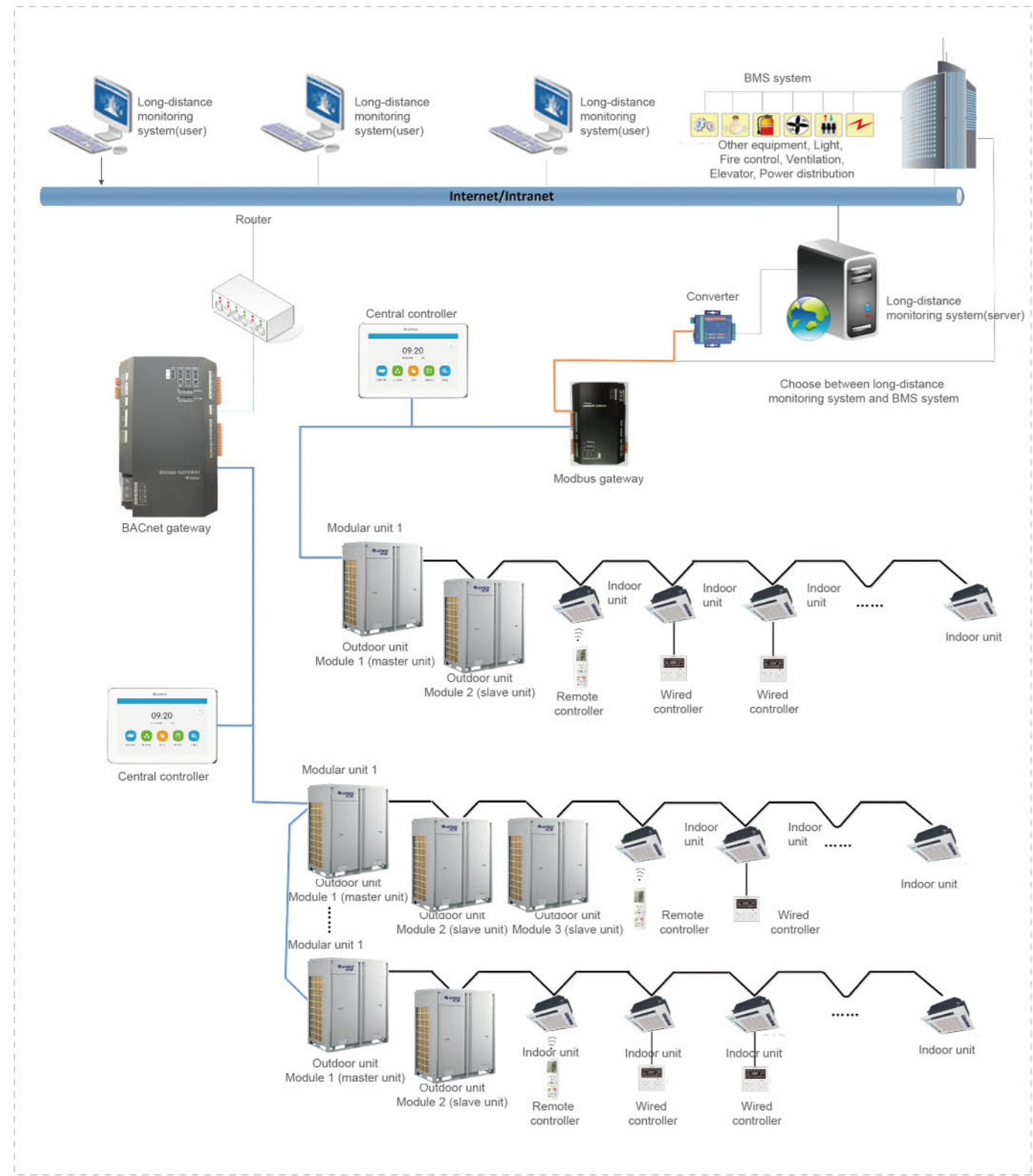

## Visualized Management

- System has a map that can display air conditioners' locations in rooms and buildings.
- System is able to measure the status and number of air conditioners in different levels



## Everyday Management

- **Setting for daily operation**
  - Management in days/weeks/months/years
  - Management in each unit
  - Simple display for management
- **Other functions**
  - Power on/off, modes, humidity, fan speed
  - Waste of energy that may be caused by forgetting to turn off the air conditioner can be avoided
- **Everyday Management at different locations**
  - Management for overtime working
  - Management for meal breaks
  - Management for working time

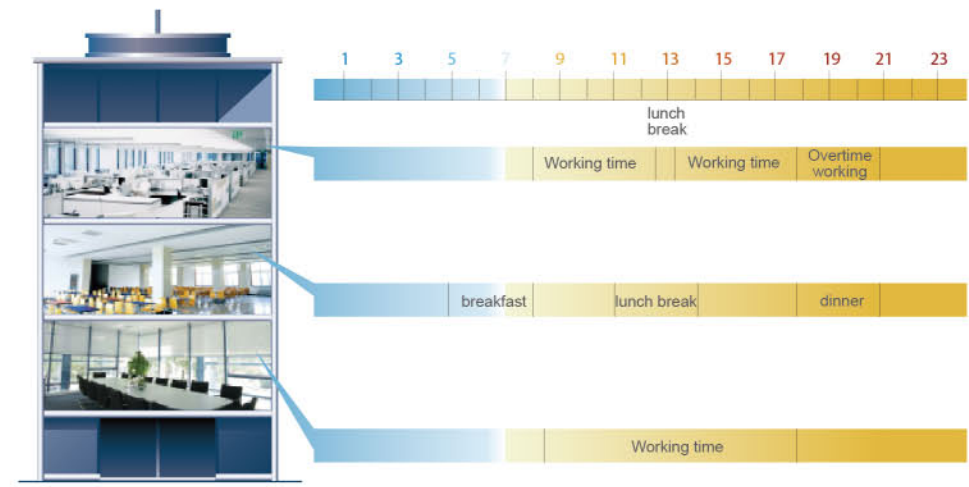

## Group Management

- **Central management in groups**
  - Free choices of dividing groups
  - Central control over power on/off
  - Central control over temperature
  - Central control over modes
  - Central control over user authority





## Authority Management

- Only for indoor units
  - Limited control over power on/off
  - Limited control over temperature
  - Limited control over modes

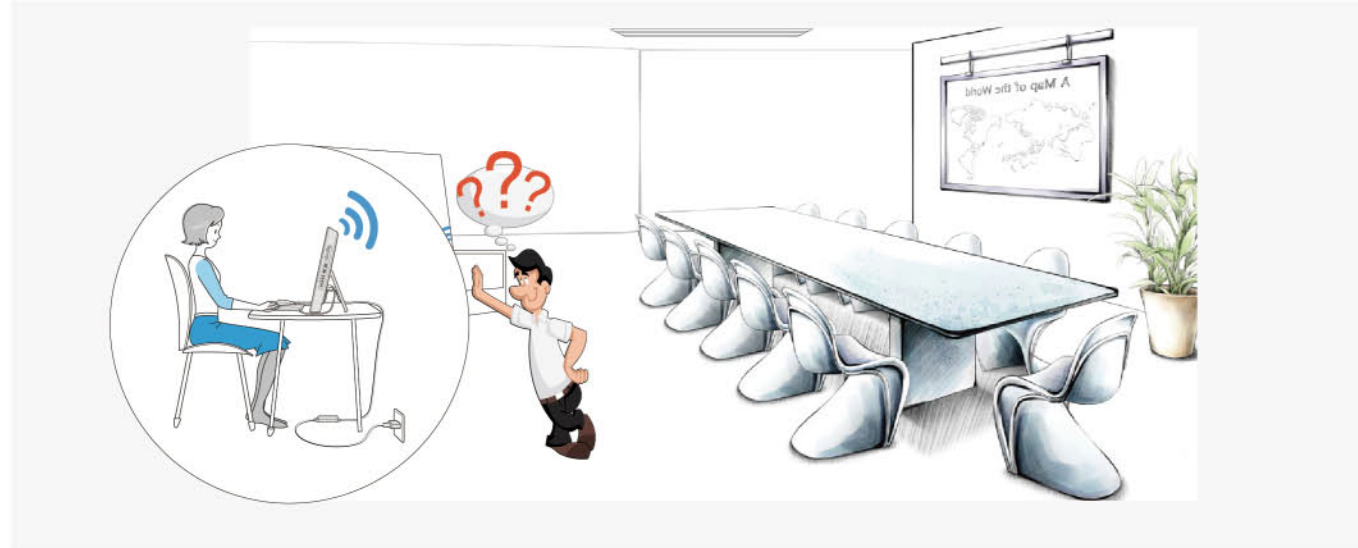

## VIP Management

System can provide independent and unique service to VIP users.



## BACnet Gateway

Gree BACnet gateway kit ME30-24/D4(B) is intended to realize the data exchange between the air conditioning unit and BAS system, and providing standard BACnet/IP building interface and 10 I/Os (five inputs are DI1, DI2, DI3, DI4, DI5 and five outputs are DO1, DO2, DO3, DO4, DO5). DI1 is the fire alarm interface. The status of other I/Os are mapped to the specific objects of the BACnet/IP bus and are defined by the user.

This gateway applies to the GMV using CAN protocol.

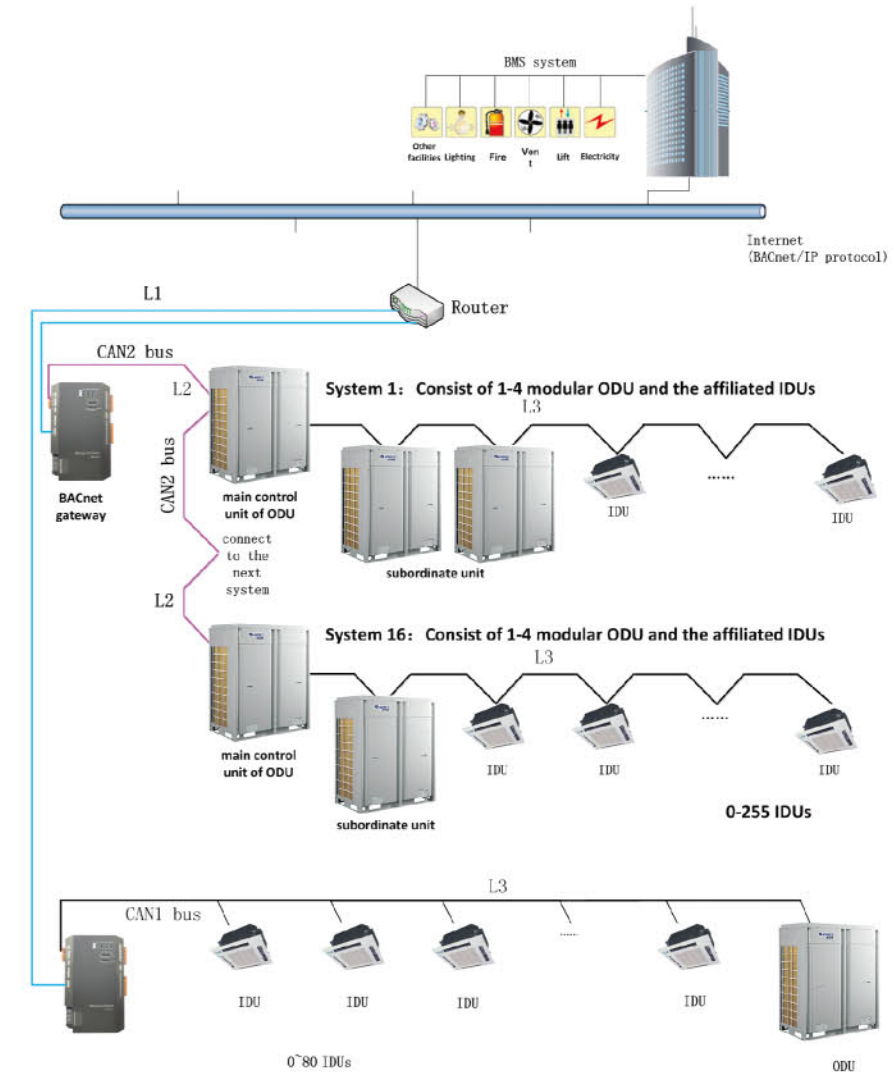

- International standard BACnet/IP interface;
- Real-time monitoring of unit operation status, e.g. on/off, mode, temperature;
- Real-time response to the control of unit (on/off, mode setting and speed setting, etc.) by monitoring software;
- Monitor unit errors;
- Lock unit operation statuses, directing at all control functions of unit itself or a certain setting function;
- Achieve cooling and heating temperature limitation functions;
- 5DI & 5DO interfaces for receiving fire alarm signal and user's definition logic;
- Up to 255 IDU units can be centrally controlled.



## Wired Controller and Remote Controller

There are two kinds of controllers: wired controller and remote controller. The system provides various controls for users, such as cooling, heating, dehumidifying and fan etc., users can select it flexibly according to their own using methods.

### Wired controller XK46



- LCD with black background and white words; touch buttons;
- Clock can be displayed and set; 24 hours timer setting for on/off;
- 7 levels of fan speed, up & down swing and left&right swing;
- Can be switched in auto, cooling, dehumidifying, fan, heating, floor heating, 3D heating and space heating operation modes;
- Master and slave wired controllers can be set; simultaneous control over several IDUs is available;
- Available functions: sleep, ventilation, quiet/auto quiet, light, energy saving, auxiliary heating, drying, memory, low-temperature dehumidifying, absence in heating, controllable auxiliary heating in dehumidifying, filter cleaning reminder, etc.;
- Detect ambient temperature; receive infrared remote controller signal;
- With project parameters viewing and setting functions;
- Dampproof structure design.

### Wired Controller XK79 (For hotel)



- Small and fashionable appearance with thickness only of 12mm and back lighting LCD with black background and white words;
- Eight touch buttons;
- Clock can be displayed and set in countdown and clock timer;
- Besides normal functions, other functions such as low-temperature dehumidifying, absence in heating, controllable auxiliary heating in dehumidifying and filter cleaning reminder can also be set;
- Door control system can be connected.

### Wired Controller XK55



- Elegant appearance;
- High-resolution color LCD;
- Capacitive touch control; receive infrared remote controller signal;
- Various timing functions: three weekly timers and one countdown timer can be set simultaneously; mode, temperature and fan speed can be preset in weekly timer;
- Complete system functions; each function will be implemented in an individual page with interactive and humanized interface;
- Various personalized functions, e.g. setting brightness and backlight time;
- Sufficient viewing functions, e.g. viewing on/off status and after-sales service hot line.

### Wired Controller XK86



- Elegant and concise appearance;
- Touch buttons with back lighting LCD;
- Chinese and English display can be switched;
- With weekly timer function;
- Complete system functions with each function implemented in an individual page;
- Refreshing, auto dehumidifying, absence and other modes can be set;
- Detect ambient temperature precisely;
- With electricity consumption inquiry function (Unit with electricity measurement function shall be connected);
- With service hotline inquiry and after-sales phone number record functions;



### Remote Controller YAP1F



- Can be switched in auto, cooling, dehumidifying, fan and heating operation modes;
- Besides turbo, 6 levels of fan speed can be set;
- Available functions: child lock, drying, health, ventilation, turbo, sleep, light, absence, I-feel and timer;
- Clock display and indoor/outdoor ambient temperature viewing functions;
- Up & down swing and left & right swing.

### Remote Controller YV1L1



- Back lighting LCD;
- Can be switched in auto, cooling, dehumidifying, fan, heating, floor heating, 3D heating and space heating operation modes;
- 7 levels of fan speed, up&down swing and left&right swing;
- Available functions: child lock, energy saving, drying, health, ventilation, quiet/auto quiet, sleep, light, absence, low-temperature dehumidifying, I-feel and timer;
- With clock display, system parameters viewing and setting functions.



- **Single control of one unit**  
Each indoor unit has an independent controller.

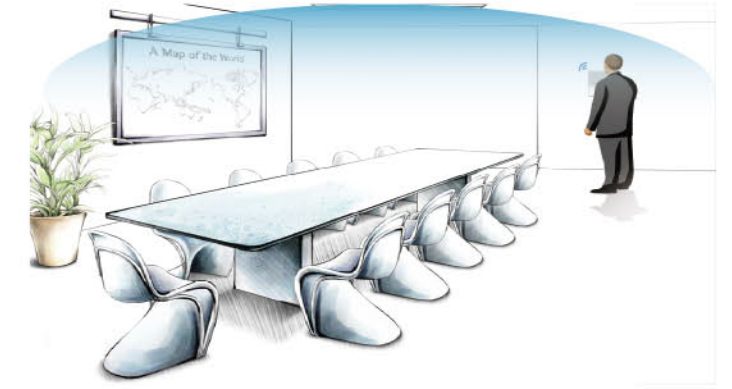

- **Multiple control of one unit**  
One indoor unit can be controlled by several wired controllers at different places.

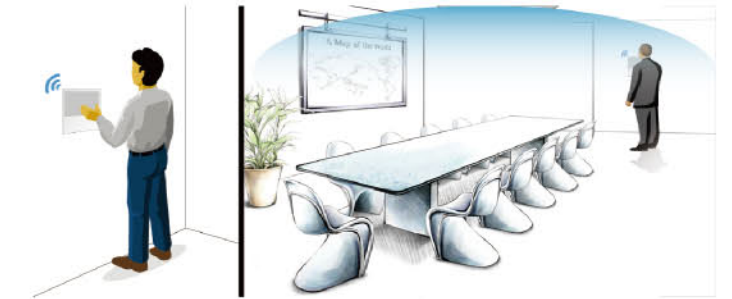

- **Central control of several indoor units**  
One wired controller can control as many as 16 indoor units.

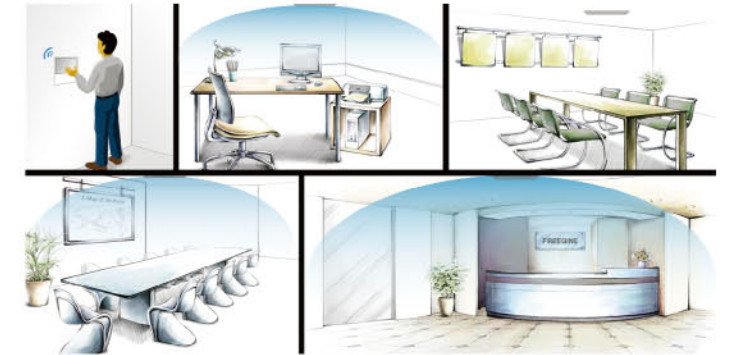

- **Joint control of remote controller and wired controller**  
Users can control one unit with two types of controllers: a remote controller which is convenient and flexible; or a wired controller which includes every function of an air conditioner.

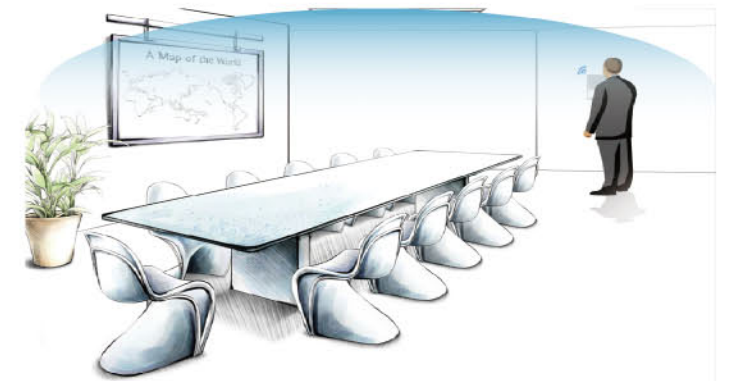



# Smart Zone Controller and Central Controller

## Smart zone controller CE53-24/F(C)

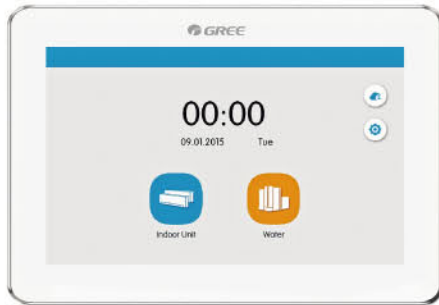

- High-resolution color LCD;
- 7" capacitive touch screen for easy operation;
- Shielding function of single unit, group and all IDUs (shielding on/off, mode, temp setting, etc.);

- With various functions: centralized control(control all indoor units), group management(support DIY grouping), schedule management(setting of several schedules) and single unit control(on/off, mode, temp setting, fan speed, quiet, swing control, etc.);
- Provide naming of indoor units, selection of icons and personalized settings(setting background, backlight, etc);
- Up to 32 units can be centrally controlled;
- Elegant and fashionable appearance;
- Embedded installation in wall with projecting thickness only of 11mm;
- Connectable with network of indoor units or outdoor units;
- Independent power supply in 110~240V wide voltage range;
- With project setting, parameter viewing, malfunction record and access management functions.

## Central controller CE52-24/F(C)

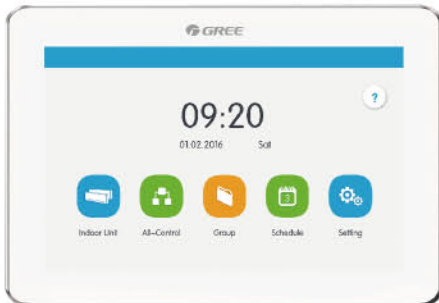

- High-resolution color LCD;
- 7" capacitive touch screen for easy operation;
- With project setting, parameter viewing, malfunction record and access management functions.

- With various functions: centralized control(control all indoor units), group management(support DIY grouping), schedule management(setting of several schedules) and single unit control(on/off, mode, temp setting, fan speed, quiet, swing control, etc.);
- Shielding function of single unit, group and all IDUs (shielding on/off, mode, temp setting, etc.);
- Provide naming of indoor units, selection of icons and personalized settings(setting background, backlight, etc);
- Up to 255 units can be centrally controlled;
- Elegant and fashionable appearance;
- Embedded installation in wall with projecting thickness only of 11mm;
- Connectable with network of indoor units or outdoor units;
- Independent power supply in 110~240V wide voltage range;

## E-smart Zone Controller CE54-24/F(C)



- Adopt built-in type installation; the exposed part is only 11mm;
- High resolution colorful LCD;
- 4.3 inch capacitive touch screen for easy operation;
- With single indoor unit control(including general functions and advanced functions), group indoor units control(including general functions and advanced functions), group management(supporting DIY group), single indoor unit and group indoor units timer functions;(general function: ON/OFF, Mode, Set, Fan, Swing, etc; advance functions: Save, Sleep, E-heater, Absence, Quiet, Turbo, etc)
- With long-distance shield function (shield switch, mode, set, etc) for single unit, group and all indoor units;
- Support denomination for indoor units, and icon selection, realizing individuation management;
- Support maximum 32 indoor units, with powerful function;
- Indoor or outdoor unit network can be connected, simple and flexible;
- 110~240V super wide voltage for independent power supply, stable and reliable;
- With functions of engineering setting, parameters view, malfunction view and authority management, easy for debugging and maintenance.



## Modbus Gateway

Modbus Gateway provides GMV5E system with the Modbus protocol interface when connecting to the Building Management System(BMS) in order to achieve central control and remote control over GMV5E system by BMS.

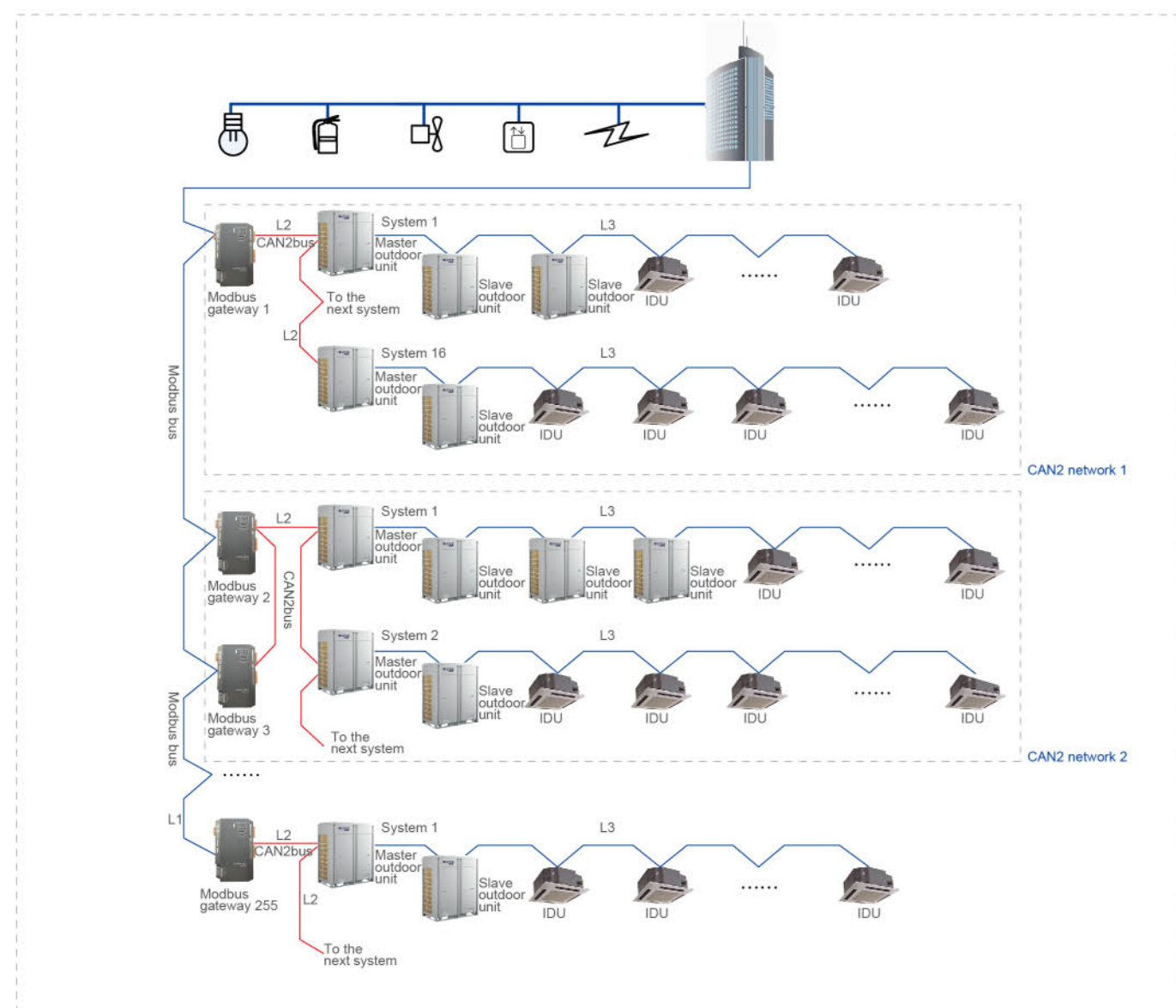

Applicable models: GMV5E All DC Inverter Multi VRF System, GMV5 DC Inverter Multi VRF System, GMV DC Inverter Water Cooled Heat Pump Multi VRF System.

- Real-time monitoring of unit operation status, e.g. on/off, mode, temperature;
- Real-time response to the control of unit (on/off, mode setting and speed setting, etc.) by monitoring software;
- Control all the units switches of on and off.
- Monitor unit errors;
- One Modbus bus can support up to 255 gateways. One Modbus gateway can support at most 16 outdoor units(up to 64 modular outdoor units) and 128 indoor units;
- Lock unit operation statuses, directing at all control functions of unit itself or a certain setting function;
- Linkage control, supporting 5 DI and 5 DO for receiving fire alarm signal and user's definition logic;
- CAN, RS485 communication ports are non-polar, convenient for construction wiring;
- Achieve cooling and heating temperature limitation functions;
- 100-240 VAC,50/60Hz wide voltage range, adapted to the power supply of each country and region.

## G-Cloud



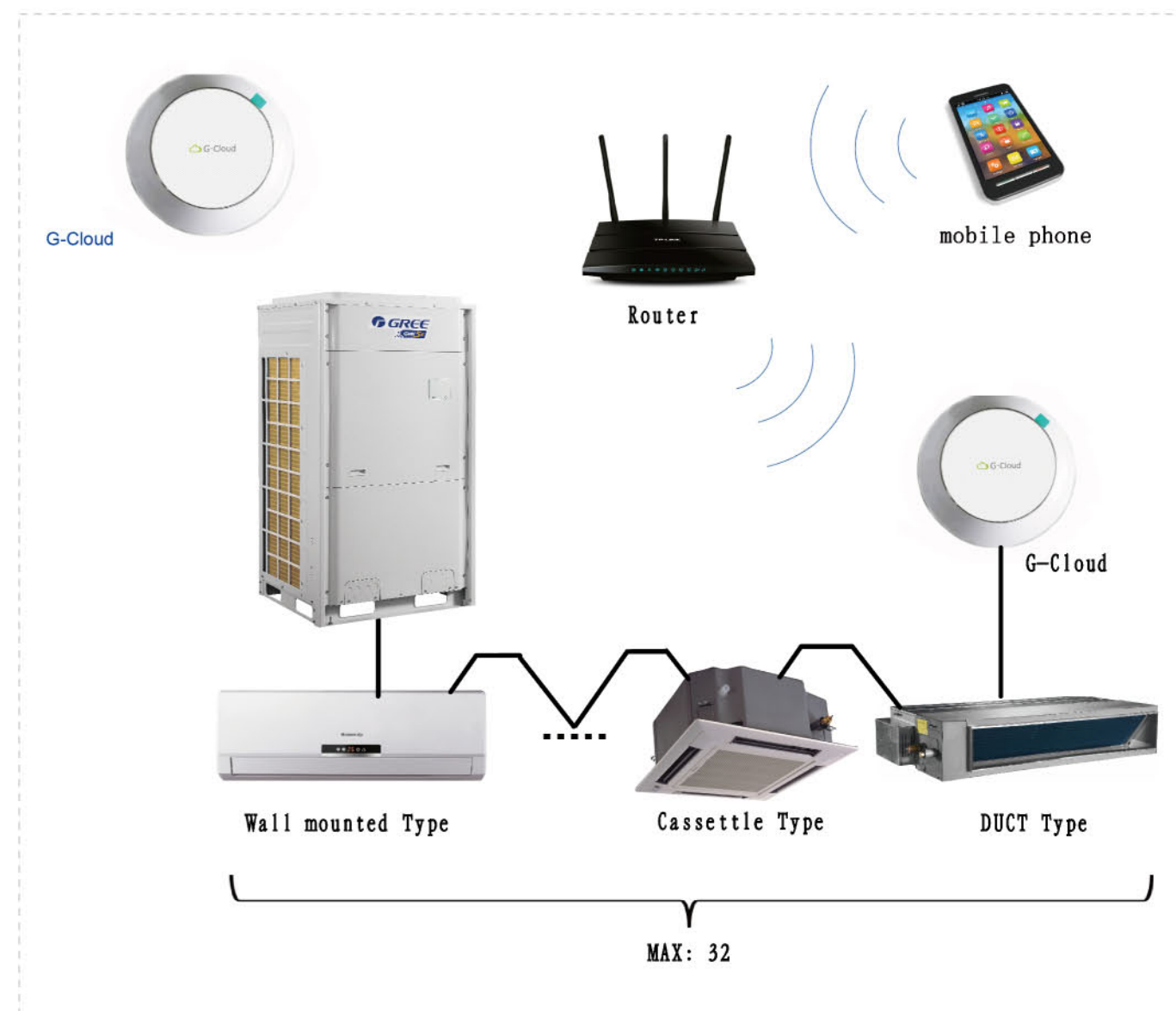













G-Cloud shall be operated with smart phone, Gree Smart and wireless router. Configure the smart phone and G-Cloud in the same router to achieve smart control, preset management, scene management, device linkage and other functions.



- Quick configuration: Connection between smart phone and G-Cloud can be achieved through pressing one button, so the configuration is quite simplified;
- Device control: User can set temperature, unit on/off and operation mode through the smart phone and view operation parameters in real time;
- Long-distance control: User can control the device from long distance through the Internet after login (G-Cloud shall be linked to the Internet);
- Scene setting: A series of commands can be set to form a scene and then you can activate the scene just by pressing one button.
- Device linkage: According to the trigger conditions set by the user, linkage in devices can be achieved;
- Preset function: User can set preset function according to his own requirement, so the device will operate automatically according to the setting.



# Control System Lineup

Controlling system		Product series	Cassette Type	(High ESP, Low ESP, Slim Ducted) Duct Type	Fresh Air Processing	Wall mounted Type	Floor Ceiling Type	Console Type	Floor Standing Type	Air Handler
Wireless Controller		YAP1F 	●	○	○	●	●	●	●	○
		YV1L1 	○	○	○	○	○	○	○	○
Wired controller		XK46 	○	●	●	○	○	○	○	●
		XK79 	○	○	○	○	○	○	○	○
		XK55 	○	○	○	○	○	○	○	○
		XK86 	○	○	○	○	○	○	○	○
		JS05(receiver) 	○	○	○	○	○	○	○	○
Centralized Controller		CE52-24/F(C) 	○	○	○	○	○	○	○	○
Smart Zone Controller		CE53-24/F(C) 	○	○	○	○	○	○	○	○
E-Smart Zone Controller		CE54-24/F(C) 	○	○	○	○	○	○	○	○
Long-distance monitoring software		FE31-00/AD(BM) 	○	○	○	○	○	○	○	○
BMS Accessories	Communication module(modbus)	ME30-24/E4(M) 	○	○	○	○	○	○	○	○
	GMV BACnet gateway (BACnet)	ME30-24/D4(B) 	○	○	○	○	○	○	○	○
Other modules	Optoelectronic isolated converter	GD02 	○	○	○	○	○	○	○	○
	Optoelectronic isolated signal multiplier	RS485-W 	○	○	○	○	○	○	○	○
G-Cloud		ME31-00/C2 	○	○	○	○	○	○	○	○

Note: ● means standard, ○ means optional.

## Branching Joint (FOR GMV5E units)

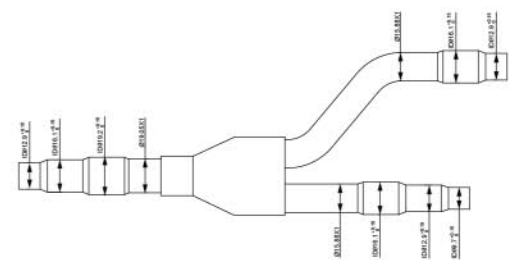
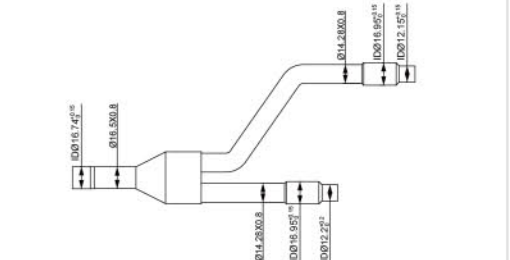
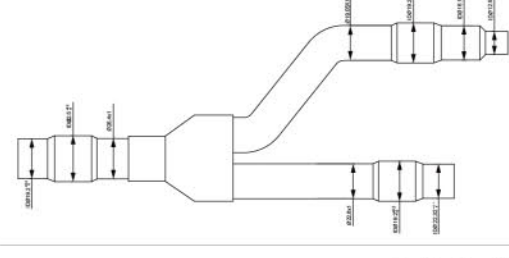
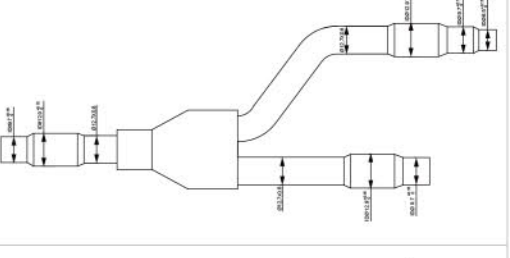
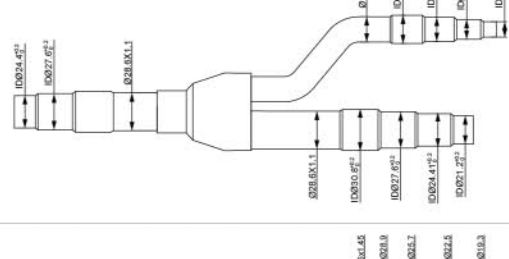
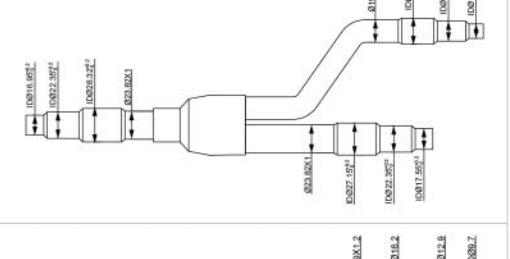
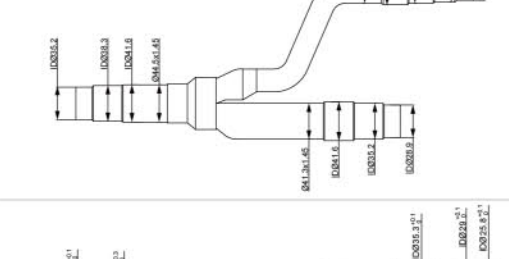
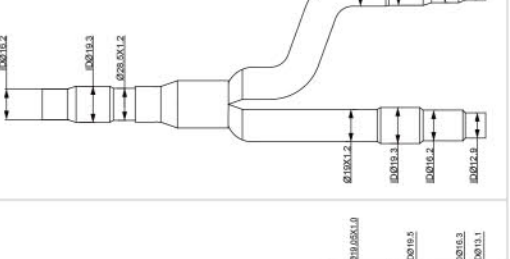
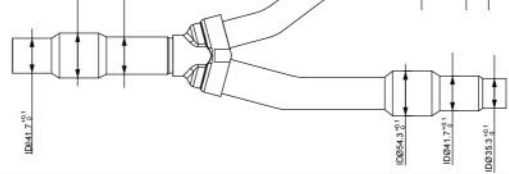
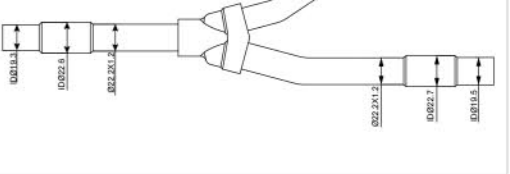
For Indoor & Outdoor Units			Appearance	
Model	Total Capacity (xkW)		Gas Pipe	Liquid Pipe
FQ01A/A	X < 20			
FQ01B/A	20 ≤ X ≤ 30			
FQ02/A	30 < X ≤ 70			
FQ03/A	70 < X ≤ 135			
FQ04/A	135 < X			





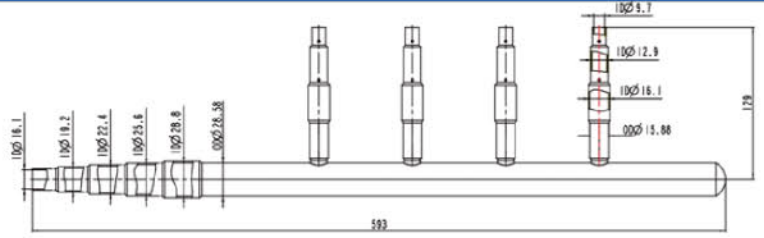
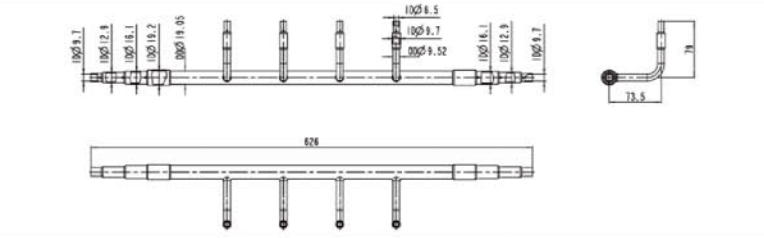
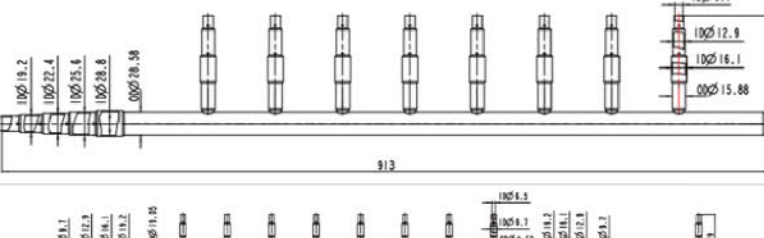
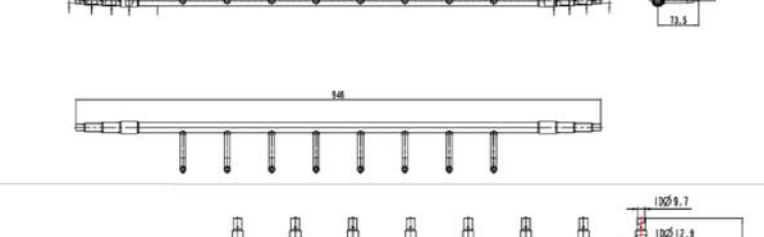
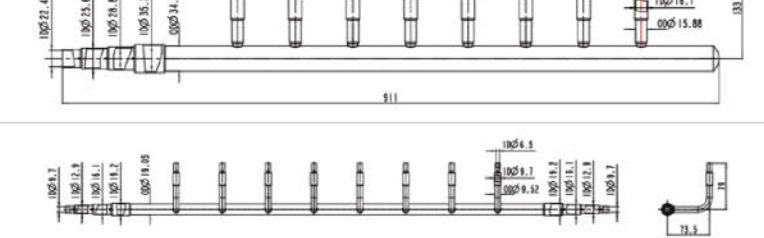
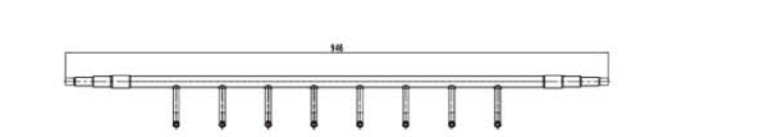





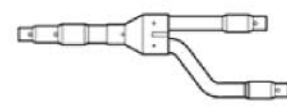

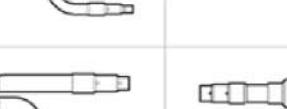





Branching Joint (FOR GMV5E units)

Model	Sort	blueprint
FQ14/H1	Gas pipe	
	Liquid pipe	
FQ18/H1	Gas pipe	
	Liquid pipe	
FQ18/H2	Gas pipe	
	Liquid pipe	

Total rated capacity of downstream indoor units X(kW)	Upstream connection pipe dimension		Model of manifold pipe
	Gas pipe(mm)	Liquid pipe(mm)	
X≤68.0	≤Φ28.6	≤Φ15.9	FQ18/H1
68.0<X	≥Φ31.8	≥Φ19.05	FQ18/H2
X≤40.0	≤Φ25.4	≤Φ12.7	FQ14/H1

Branching Joint (FOR GMV5 HR)

For Indoor Units				
Model	Total capacity of the downstream indoor unit X(kW)	Appearance		
		High-pressure gas pipe	Low-pressure gas pipe	Liquid pipe
FQ01Na/A	X≤5.0			
FQ02Na/A	5.0<X≤22.4			
FQ03Na/A	22.4<X≤28.0			
FQ04Na/A	28.0<X≤68			
FQ05Na/A	68 < X ≤ 96			
FQ06Na/A	96 < X ≤ 135			
FQ07Na/A	135 < X			

For Outdoor Units				
Model	Module's capacity X(kW)	Appearance		
		High-pressure gas pipe	Low-pressure gas pipe	Liquid pipe
ML01R	50.4≤X≤96			
ML02R	96 < X	