



Service Manual

GREE ELECTRIC APPLIANCES, INC. OF ZHUHAI



Table of Contents

Part I : Technical Information	1
1. Summary	1
2. Specifications	6
2.1 Specification Sheet.....	6
2.2 Operation Characteristic Curve.....	18
2.3 Capacity Variation Ratio According to Temperature.....	18
2.4 Cooling and Heating Data Sheet in Rated Frequency.....	19
2.5 Noise Curve.....	19
3. Outline Dimension Diagram	21
3.1 Indoor Unit.....	21
3.2 Outdoor Unit.....	22
4. Refrigerant System Diagram	24
5. Electrical Part	25
5.1 Wiring Diagram.....	25
5.2 PCB Printed Diagram.....	33
6. Function and Control	39
6.1 Remote Controller Introduction.....	39
6.2 GREE+ App Operation Manual.....	44
6.3 Ewpe Smart App Operation Manual.....	45
6.4 Brief Description of Modes and Functions.....	46
Part II : Installation and Maintenance	50
7. Notes for Installation and Maintenance	50
8. Installation	54
8.1 Installation Dimension Diagram.....	54
8.2 Installation Parts-checking.....	56
8.3 Selection of Installation Location.....	56
8.4 Requirements for electric connection.....	56
8.5 Installation of Indoor Unit.....	57
8.6 Installation of Outdoor Unit.....	59
8.7 Vacuum Pumping and Leak Detection.....	60
8.8 Check after Installation and Test Operation.....	60

9. Maintenance	61
9.1 Error Code List	61
9.2 Procedure of Troubleshooting	69
9.3 Troubleshooting for Normal Malfunction	83
10. Exploded View and Parts List	85
10.1 Indoor Unit	85
10.2 Outdoor Unit	111
11. Removal Procedure	120
11.1 Removal Procedure of Indoor Unit	120
11.2 Removal Procedure of Outdoor Unit	130
Appendix:	150
Appendix 1: Reference Sheet of Celsius and Fahrenheit	150
Appendix 2: Configuration of Connection Pipe	150
Appendix 3: Pipe Expanding Method	151
Appendix 4: List of Resistance for Temperature Sensor	152

Part I : Technical Information

1. Summary

Indoor Unit

GWH09QB-K6DNA1C/I GWH12QC-K6DNA1C/I
 GWH09QB-K6DNA1I/I GWH18QD-K6DNA1B/I
 GWH12QC-K6DNA1D/I GWH09QB-K6DNA1E/I

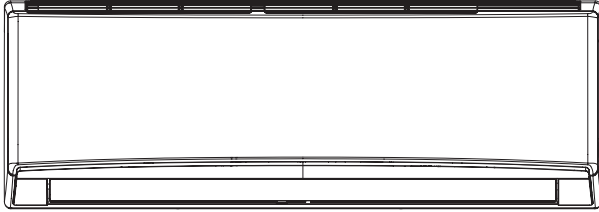

GWH09QB-K6DND4C/I
 GWH12QC-K6DND4C/I

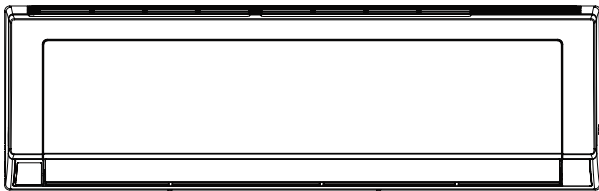

GWH09QB-K6DNC2C/I GWH09QB-K6DNC2I/I
 GWH12QC-K6DNC2C/I GWH12QB-K6DNC2I/I

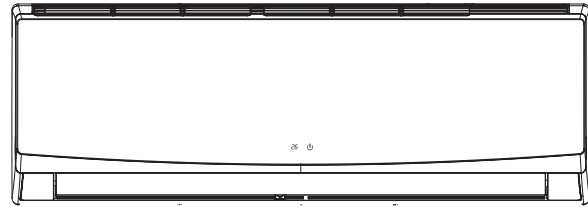

GWH09QB-K6DNC8C/I GWH12QC-K6DNC8C/I
 GWH18QD-K6DNC8C/I GWH09QB-K6DNC8I/I

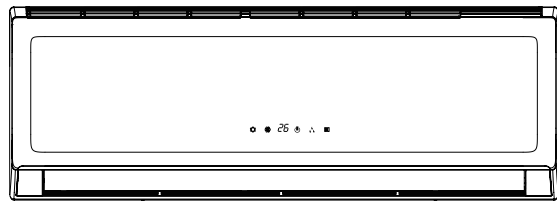

GWH09QB-K6DNB8I/I

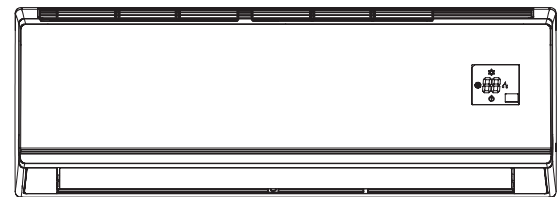

GWH09QB-K6DNA2I/I

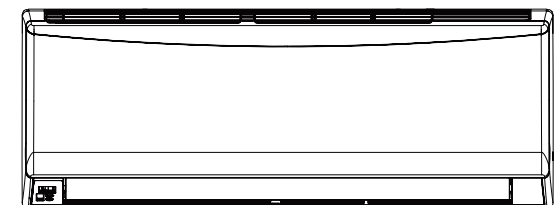

GWH09QB-K6DNA3C/I
 GWH09QB-K6DNA3I/I
 GWH12QC-K6DNA3C/I

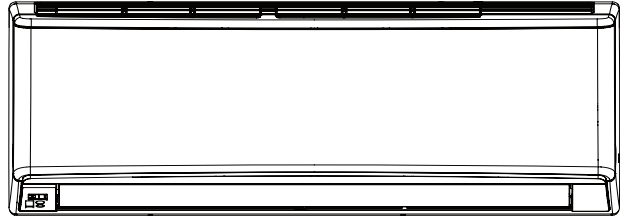

GWH09QB-K6DNE6C/I
 GWH12QC-K6DNE6C/I

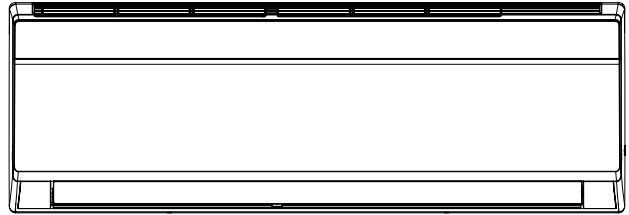

GWH09QB-K6DND6C/I GWH09QB-K6DND6I/I
 GWH12QC-K6DND6C/I GWH18QD-K6DND6B/I

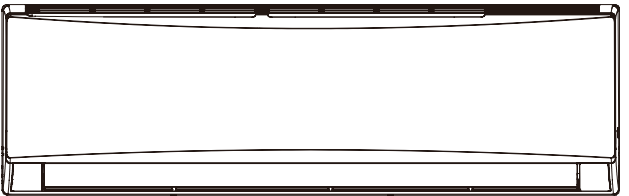

GWH12QC-K6DNB6C/I
 GWH09QB-K6DNB6C/I

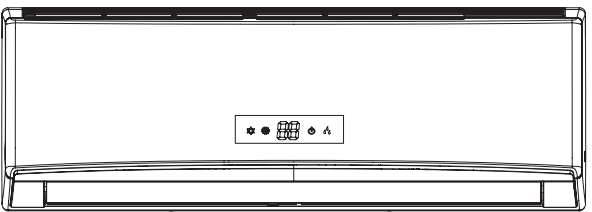

GWH09QB-K6DNE4C/I GWH12QC-K6DNE4C/I
 GWH09QB-K6DNE4I/I GWH12QB-K6DNE4I/I

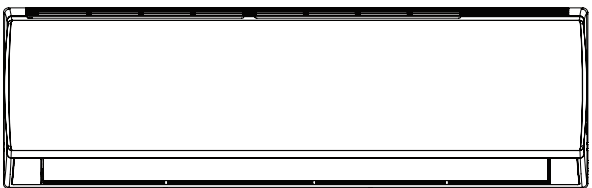

GWH09QB-K6DNA6I/I GWH12QB-K6DNA6I/I



GWH09QB-K6DNB2C/I
GWH12QC-K6DNB2C/I

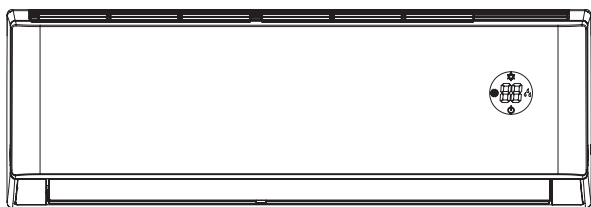

GWH09QB-K6DNB4C/I GWH09QB-K6DNB4I/I
GWH18QD-K6DNB4B/I GWH12QC-K6DNB4C/I

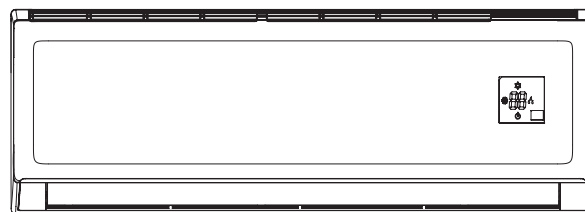

GWH09QB-K6DNC4I/I GWH09QB-K6DNC4C/I
GWH12QB-K6DNC4I/I GWH12QC-K6DNC4C/I

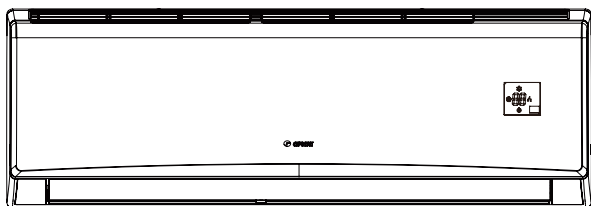

GWH09QB-K6DNA5I/I GWH18QD-K6DNA5B/I

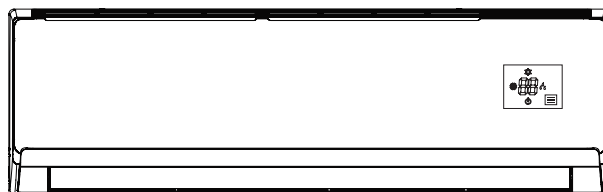

GWH09QB-K6DNC6I/I

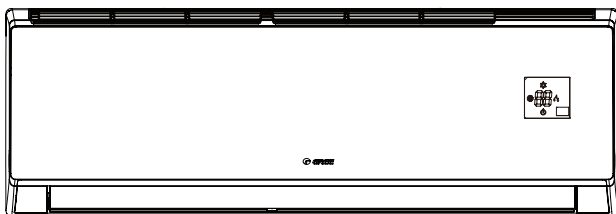

GWH18QD-K6DND8B/I GWH09QB-K6DND8I/I

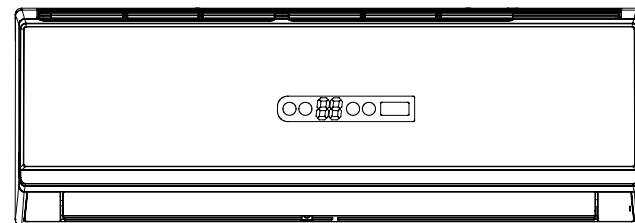

Outdoor Unit

GWH09QB-K6DNA1C/O

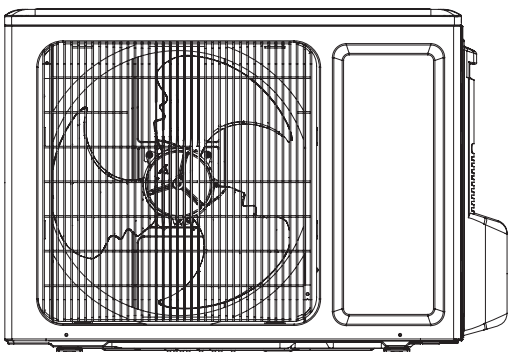

GWH09QB-K6DNB8I/O

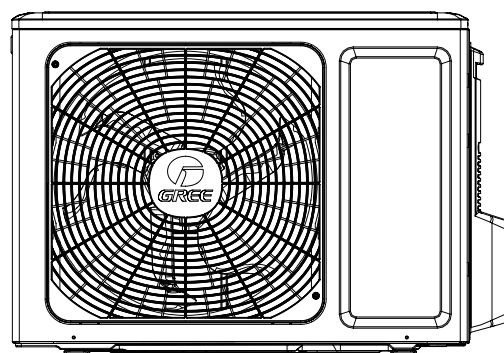

GWH12QC-K6DNA1C/O
GWH12QB-K6DNB8I/O
GWH18AAD-K6DNA1B/O

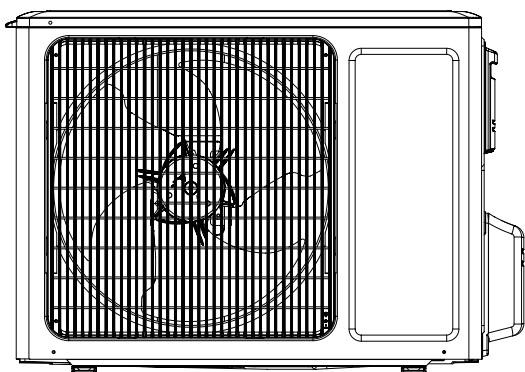

GWH18QD-K6DNA1C/O

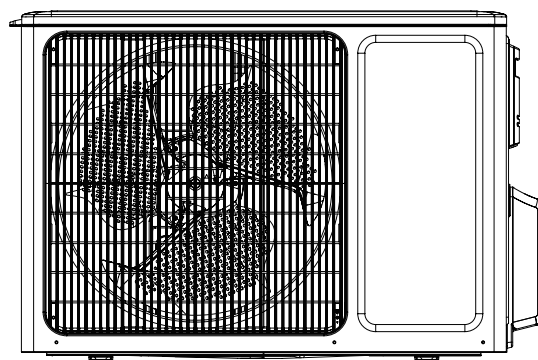

Model List:

No	Model	Product code	Indoor model	Indoor product code	Outdoor model	Outdoor product code	Remote Controller
1	GWH09QB-K6DNA3C	CB424004900	GWH09QB-K6DNA3C/I	CB424N04900	GWH09QB-K6DNA1C/O	CB419W11900	
2	GWH09QB-K6DND4C	CB464000300	GWH09QB-K6DND4C/I	CB464N00300			
3	GWH09QB-K6DND4C	CB464000302	GWH09QB-K6DND4C/I	CB464N00302			
4	GWH09QB-K6DNE6C	CB465000600	GWH09QB-K6DNE6C/I	CB465N00600			
5	GWH09QB-K6DNE6C	CB465000601	GWH09QB-K6DNE6C/I	CB465N00601			
6	GWH09QB-K6DND6C	CB460003000	GWH09QB-K6DND6C/I	CB460N03000			
7	GWH09QB-K6DND6C	CB460003002	GWH09QB-K6DND6C/I	CB460N03002			
8	GWH09QB-K6DNC8C	CB456003500	GWH09QB-K6DNC8C/I	CB456N03500			
9	GWH09QB-K6DNE4C	CB470002000	GWH09QB-K6DNE4C/I	CB470N02000			
10	GWH09QB-K6DNB4C	CB434011300	GWH09QB-K6DNB4C/I	CB434N11300			
11	GWH09QB-K6DNB2C	CB432012502	GWH09QB-K6DNB2C/I	CB432N12501			
12	GWH09QB-K6DNB6C	CB435007500	GWH09QB-K6DNB6C/I	CB435N07500			
13	GWH09QB-K6DNC2C	CB439009201	GWH09QB-K6DNC2C/I	CB439N09201			
14	GWH09QB-K6DNB4C	CB434011301	GWH09QB-K6DNB4C/I	CB434N11301			
15	GWH09QB-K6DNA1C	CB419011900	GWH09QB-K6DNA1C/I	CB419N11900			
16		CB419011901					
17	GWH09QB-K6DNB6C	CB435007501	GWH09QB-K6DNB6C/I	CB435N07500	CB419W11901		
18	GWH09QB-K6DNB2C	CB432012501	GWH09QB-K6DNB2C/I	CB432N12500			
19	GWH09QB-K6DND6C	CB460003001	GWH09QB-K6DND6C/I	CB460N03000			
20	GWH09QB-K6DNC4C	CB444009201	GWH09QB-K6DNC4C/I	CB444N09200			
21	GWH09QB-K6DNC2C	CB439009202	GWH09QB-K6DNC2C/I	CB439N09200			
22	GWH09QB-K6DNB8I	CB438007400	GWH09QB-K6DNB8I/I	CB438N07400			GWH09QB-K6DNB8I/O
23	GWH09QB-K6DNC4I	CB444007400	GWH09QB-K6DNC4I/I	CB444N07400			
24	GWH09QB-K6DNE4I	CB470002200	GWH09QB-K6DNE4I/I	CB470N02200			
25	GWH09QB-K6DNA1I	CB419015100	GWH09QB-K6DNA1I/I	CB419N15100			
26	GWH09QB-K6DNB4I	CB434011500	GWH09QB-K6DNB4I/I	CB434N11500			
27	GWH09QB-K6DND6I	CB460005600	GWH09QB-K6DND6I/I	CB460N05600			
28	GWH09QB-K6DNA5I	CB425011700	GWH09QB-K6DNA5I/I	CB425N11700			
29	GWH09QB-K6DNA3I	CB424006800	GWH09QB-K6DNA3I/I	CB424N06800			
30	GWH09QB-K6DNB8I	CB438007401	GWH09QB-K6DNB8I/I	CB438N07401			
31	GWH09QB-K6DND6I	CB460005601	GWH09QB-K6DND6I/I	CB460N05601			
32	GWH09QB-K6DNE4I	CB470002201	GWH09QB-K6DNE4I/I	CB470N02201			
33	GWH09QB-K6DNC6I	CB443005200	GWH09QB-K6DNC6I/I	CB443N05200			
34	GWH09QB-K6DNC2I	CB439012600	GWH09QB-K6DNC2I/I	CB439N12600			
35	GWH09QB-K6DNC2I	CB439012601	GWH09QB-K6DNC2I/I	CB439N12601			
36	GWH09QB-K6DNC8I	CB456006100	GWH09QB-K6DNC8I/I	CB456N06100			
37	GWH09QB-K6DNB4I	CB434011501	GWH09QB-K6DNB4I/I	CB434N11501			
38	GWH09QB-K6DNA2I	CB426006600	GWH09QB-K6DNA2I/I	CB426N06600			
39	GWH12QC-K6DND4C	CB464000200	GWH12QC-K6DND4C/I	CB464N00200	GWH12QC-K6DNA1C/O	CB419W12300	
40	GWH12QC-K6DNE6C	CB465000500	GWH12QC-K6DNE6C/I	CB465N00500			
41	GWH12QC-K6DNA3C	CB424005200	GWH12QC-K6DNA3C/I	CB424N05200			
42	GWH12QC-K6DNC8C	CB456003200	GWH12QC-K6DNC8C/I	CB456N03200			
43	GWH12QC-K6DNB4C	CB434012000	GWH12QC-K6DNB4C/I	CB434N12000			
44	GWH12QC-K6DNB2C	CB432014802	GWH12QC-K6DNB2C/I	CB432N14801			
45	GWH12QC-K6DNB6C	CB435007300	GWH12QC-K6DNB6C/I	CB435N07300			
46	GWH12QC-K6DNB4C	CB434012001	GWH12QC-K6DNB4C/I	CB434N12001			
47	GWH12QC-K6DNC2C	CB439009403	GWH12QC-K6DNC2C/I	CB439N09403			
48	GWH12QC-K6DNA1C	CB419012300	GWH12QC-K6DNA1C/I	CB419N12300			
49		CB419012301					
50	GWH12QC-K6DNB6C	CB435007301	GWH12QC-K6DNB6C/I	CB435N07300			CB419W12301
51	GWH12QC-K6DNE4C	CB470002101	GWH12QC-K6DNE4C/I	CB470N02100			
52	GWH12QC-K6DND6C	CB460003501	GWH12QC-K6DND6C/I	CB460N03500			
53	GWH12QC-K6DNB2C	CB432014801	GWH12QC-K6DNB2C/I	CB432N14800			
54	GWH12QC-K6DNC4C	CB444009301	GWH12QC-K6DNC4C/I	CB444N09300			
55	GWH12QB-K6DNC4I	CB444007500	GWH12QB-K6DNC4I/I	CB444N07500	GWH12QB-K6DNB8I/O	CB438W06800	
56	GWH12QB-K6DNE4I	CB470002300	GWH12QB-K6DNE4I/I	CB470N02300			
57	GWH12QB-K6DNE4I	CB470002301	GWH12QB-K6DNE4I/I	CB470N02301			
58	GWH12QB-K6DNC2I	CB439012700	GWH12QB-K6DNC2I/I	CB439N12700	GWH18QD-K6DNA1C/O	CB419W12500	
59	GWH12QB-K6DNC2I	CB439012701	GWH12QB-K6DNC2I/I	CB439N12701			
60	GWH18QD-K6DNC8C	CB456003400	GWH18QD-K6DNC8C/I	CB456N03400	GWH18AAD-K6DNA1B/O	CB476W00600	
61	GWH18QD-K6DNB4B	CB434011200	GWH18QD-K6DNB4B/I	CB434N11200			
62	GWH18QD-K6DNA1B	CB419015200	GWH18QD-K6DNA1B/I	CB419N15200			
63	GWH18QD-K6DND6B	CB460005301	GWH18QD-K6DND6B/I	CB460N05301			
64	GWH18QD-K6DNA5B	CB425011900	GWH18QD-K6DNA5B/I	CB425N11900			
65	GWH18QD-K6DNB4B	CB434011201	GWH18QD-K6DNB4B/I	CB434N11201			

2. Specifications

2.1 Specification Sheet

Parameter		Unit	Value
Model			1.GWH09QB-K6DNA1C 2.GWH09QB-K6DNA3C 3.GWH09QB-K6DND4C 4.GWH09QB-K6DNE6C 5.GWH09QB-K6DND6C 6.GWH09QB-K6DNC8C 7.GWH09QB-K6DNE4C 8.GWH09QB-K6DNB4C 9.GWH09QB-K6DND6C 10.GWH09QB-K6DNB2C 11.GWH09QB-K6DNB6C 12.GWH09QB-K6DNC2C
Product Code			1.CB419011900 2.CB424004900 3.CB464000300/CB464000302 4.CB465000600/CB465000601 5.CB460003000 6.CB456003500 7.CB470002000 8.CB434011300/CB434011301 9.CB460003002 10.CB432012502 11.CB435007500 12.CB439009201
Power Supply	Rated Voltage	V~	220-240
	Rated Frequency	Hz	50
	Phases		1
Power Supply Mode			Outdoor
Cooling Capacity(Min~Max)		W	2600(500~3350)
Heating Capacity(Min~Max)		W	2800(500~3500)
Cooling Power Input(Min~Max)		W	805(160~1400)
Heating Power Input(Min~Max)		W	755(200~1500)
Cooling Current Input		A	3.9
Heating Current Input		A	3.4
Rated Input		W	1500
Rated Current		A	6.3
Air Flow Volume(SH/H/M/L/SL)		m ³ /h	560/490/430/330/-
Dehumidifying Volume		L/h	0.8
EER		W/W	3.23
COP		W/W	3.71
SEER		W/W	6.1
SCOP(Average/Warmer/Colder)		W/W	4.0/5.1/3.2
Application Area		m ²	12-18
Indoor Unit	Indoor Unit Model		1.GWH09QB-K6DNA1C/I 2.GWH09QB-K6DNA3C/I 3.GWH09QB-K6DND4C/I 4.GWH09QB-K6DNE6C/I 5.GWH09QB-K6DND6C/I 6.GWH09QB-K6DNC8C/I 7.GWH09QB-K6DNE4C/I 8.GWH09QB-K6DNB4C/I 9.GWH09QB-K6DND6C/I 10.GWH09QB-K6DNB2C/I 11.GWH09QB-K6DNB6C/I 12.GWH09QB-K6DNC2C/I
	Indoor Unit Product Code		1.CB419N11900 2.CB424N04900 3.CB464N00300/CB464N00302 4.CB465N00600/CB465N00601 5.CB460N03000 6.CB456N03500 7.CB470N02000 8.CB434N11300/CB434N11301 9.CB460N03002 10.CB432N12501 11.CB435N07500 12.CB439N09201
	Fan Type		Cross-flow
	Fan Diameter Length(DXL)	mm	Φ98X580
	Cooling Speed(SH/H/M/L/SL)	r/min	1300/1200/1050/800/-
	Heating Speed(SH/H/M/L/SL)	r/min	1300/1200/1050/900/-
	Fan Motor Power Output	W	20
	Fan Motor RLA	A	0.215
	Fan Motor Capacitor	μF	1
	Evaporator Form		Aluminum Fin-copper Tube
	Evaporator Pipe Diameter	mm	Φ5
	Evaporator Row-fin Gap	mm	2-1.4
	Evaporator Coil Length (LXD _X W)	mm	584X22.8X266.7
	Swing Motor Model		MP24AA
	Swing Motor Power Output	W	1.5
	Fuse Current	A	3.15
	Sound Pressure Level(SH/H/M/L/SL)	dB (A)	39/36/32/28/-
	Sound Power Level(SH/H/M/L/SL)	dB (A)	55/52/44/38/-
	Dimension (WXHXD)	mm	790X275X200
	Dimension of Carton Box (LXWXH)	mm	863X268X352
Dimension of Package(LXWXH)	mm	866X271X367	
Net Weight	kg	9	
Gross Weight	kg	11	

Outdoor Unit	Outdoor Unit Model		GWH09QB-K6DNA1C/O	
	Outdoor Unit Product Code		CB419W11900	
	Compressor Manufacturer		ZHUHAI LANDA COMPRESSOR CO.,LTD	
	Compressor Model		QXF-B096zE190A	
	Compressor Oil		FW68DA	
	Compressor Type		Rotary	
	Compressor LRA.	A		20.00
	Compressor RLA	A		4.21
	Compressor Power Input	W		943
	Compressor Overload Protector			1NT11L-6233 HPC115/95U1 KSD115°C
	Throttling Method			Capillary
	Set Temperature Range	°C		16~30
	Cooling Operation Ambient Temperature Range	°C		-15~43
	Heating Operation Ambient Temperature Range	°C		-15~24
	Condenser Form			Aluminum Fin-copper Tube
	Condenser Pipe Diameter	mm		Φ7
	Condenser Rows-fin Gap	mm		1-1.4
	Condenser Coil Length (LXDXW)	mm		710X19.05X508
	Fan Motor Speed	rpm		900
	Fan Motor Power Output	W		30
	Fan Motor RLA	A		0.36
	Fan Motor Capacitor	μF		/
	Outdoor Unit Air Flow Volume	m ³ /h		1600
	Fan Type			Axial-flow
	Fan Diameter	mm		Φ400
	Defrosting Method			Automatic Defrosting
	Climate Type			T1
	Isolation			I
	Moisture Protection			IPX4
	Permissible Excessive Operating Pressure for the Discharge Side	MPa		4.3
	Permissible Excessive Operating Pressure for the Suction Side	MPa		2.5
	Sound Pressure Level (H/M/L)	dB (A)		52/-/-
Sound Power Level (H/M/L)	dB (A)		61/-/-	
Dimension(WXHXD)	mm		782X540X320	
Dimension of Carton Box (LXWXH)	mm		820X355X580	
Dimension of Package(LXWXH)	mm		823X358X595	
Net Weight	kg		29.5	
Gross Weight	kg		32	
Refrigerant			R32	
Refrigerant Charge	kg		0.6	
Connection Pipe	Connection Pipe Length	m	5	
	Connection Pipe Gas Additional Charge	g/m	16	
	Outer Diameter Liquid Pipe	mm	Φ6	
	Outer Diameter Gas Pipe	mm	Φ9.52	
	Max Distance Height	m	10	
	Max Distance Length	m	15	
Note: The connection pipe applies metric diameter.				

The above data is subject to change without notice. Please refer to the nameplate of the unit.

Parameter		Unit	Value	
Model			GWH09QB-K6DNA1C(LCLH) GWH09QB-K6DNB6C GWH09QB-K6DNB2C GWH09QB-K6DND6C GWH09QB-K6DNC4C	1.GWH09QB-K6DNB8I 2.GWH09QB-K6DNC4I 3.GWH09QB-K6DNE4I 4.GWH09QB-K6DNB4I 5.GWH09QB-K6DNA1I 6.GWH09QB-K6DND6I 7.GWH09QB-K6DNA5I 8.GWH09QB-K6DNA3I 9.GWH09QB-K6DNB8I 10.GWH09QB-K6DND6I 11.GWH09QB-K6DNE4I 12.GWH09QB-K6DNC6I 13.GWH09QB-K6DNC2I 14.GWH09QB-K6DNC8I 15.GWH09QB-K6DNA2I 16.GWH09QB-K6DNA6I 17.GWH09QB-K6DND8I
Product Code			CB419011901 CB435007501 CB432012501 CB460003001 CB444009201	1.CB438007400 2.CB444007400 3.CB470002200 4.(CB434011500/ CB434011501) 5.CB419015100 6.CB460005600 7.CB425011700 8.CB424006800 9.CB438007401 10.CB460005601 11.CB470002201 12.CB443005200 13.CB439012600/ CB439012601 14.CB456006100 15.CB426006600 16.CB427010200 17.CB459005000
Power Supply	Rated Voltage	V~	220-240	220-240
	Rated Frequency	Hz	50	50
	Phases		1	1
Power Supply Mode			Outdoor	Outdoor
Cooling Capacity(Min~Max)		W	2600(500~3350)	2600(500~3350)
Heating Capacity(Min~Max)		W	2800(500~3500)	2800(500~3500)
Cooling Power Input(Min~Max)		W	805(160~1400)	805(160~1400)
Heating Power Input(Min~Max)		W	755(200~1500)	755(200~1500)
Cooling Current Input		A	3.9	3.9
Heating Current Input		A	3.4	3.4
Rated Input		W	1500	1500
Rated Current		A	6.3	6.3
Air Flow Volume(SH/H/M//L/SL)		m ³ /h	560/490/430/330/-	560/490/430/330/-
Dehumidifying Volume		L/h	0.8	0.8
EER		W/W	3.23	3.23
COP		W/W	3.71	3.71
SEER		W/W	6.1	6.1
SCOP(Average/Warmer/Colder)		W/W	4.0/5.1/3.2	4.0/5.1/3.2
Application Area		m ²	12-18	12-18
Indoor Unit	Fan Type		Cross-flow	Cross-flow
	Fan Diameter Length(DXL)	mm	Φ98X580	Φ98X580
	Cooling Speed(SH/H/M//L/SL)	r/min	1300/1200/1050/800/-	1300/1200/1050/800/-
	Heating Speed(SH/H/M//L/SL)	r/min	1300/1200/1050/900/-	1300/1200/1050/900/-
	Fan Motor Power Output	W	20	20
	Fan Motor RLA	A	0.215	0.215
	Fan Motor Capacitor	μF	1	1
	Evaporator Form		Aluminum Fin-copper Tube	Aluminum Fin-copper Tube
	Evaporator Pipe Diameter	mm	Φ5	Φ5
	Evaporator Row-fin Gap	mm	2-1.4	2-1.4
	Evaporator Coil Length (LXDXW)	mm	584X22.8X266.7	584X22.8X266.7
	Swing Motor Model		MP24AA	MP24AA
	Swing Motor Power Output	W	1.5	1.5
	Fuse Current	A	3.15	3.15
	Sound Pressure Level(SH/H/M//L/SL)	dB (A)	39/36/32/28/-	39/36/32/28/-
	Sound Power Level(SH/H/M//L/SL)	dB (A)	55/52/44/38/-	55/52/44/38/-
	Dimension (WXHXD)	mm	790X275X200	790X275X200
	Dimension of Carton Box (LXWXH)	mm	863X268X352	863X268X352
	Dimension of Package(LXWXH)	mm	866X271X367	866X271X367
	Net Weight	kg	9	9
Gross Weight	kg	11	11	

Outdoor Unit	Outdoor Unit Model		GWH09QB-K6DNA1C/O(LCLH)	GWH09QB-K6DNB8I/O(LC)
	Outdoor Unit Product Code		CB419W11901	CB438W07400
	Compressor Manufacturer		ZHUHAI LANDA COMPRESSOR CO.,LTD	ZHUHAI LANDA COMPRESSOR CO.,LTD
	Compressor Model		QXF-B096zE190A	QXF-B096zE190A
	Compressor Oil		FW68DA	FW68DA
	Compressor Type		Rotary	Rotary
	Compressor LRA.	A	20.00	20.00
	Compressor RLA	A	4.21	4.21
	Compressor Power Input	W	943	943
	Compressor Overload Protector		1NT11L-6233 HPC115/95U1 KSD115°C	1NT11L-6233 HPC115/95U1 KSD115°C
	Throttling Method		Capillary	Capillary
	Set Temperature Range	°C	16~30	16~30
	Cooling Operation Ambient Temperature Range	°C	-15~43	-15~43
	Heating Operation Ambient Temperature Range	°C	-15~24	-15~24
	Condenser Form		Aluminum Fin-copper Tube	Aluminum Fin-copper Tube
	Condenser Pipe Diameter	mm	Φ7	Φ7
	Condenser Rows-fin Gap	mm	1-1.4	1-1.4
	Condenser Coil Length (LXDXW)	mm	710X19.05X508	710X19.05X508
	Fan Motor Speed	rpm	900	900
	Fan Motor Power Output	W	30	30
	Fan Motor RLA	A	0.36	0.36
	Fan Motor Capacitor	μF	/	/
	Outdoor Unit Air Flow Volume	m ³ /h	1600	1600
	Fan Type		Axial-flow	Axial-flow
	Fan Diameter	mm	Φ400	Φ400
	Defrosting Method		Automatic Defrosting	Automatic Defrosting
	Climate Type		T1	T1
	Isolation		I	I
	Moisture Protection		IPX4	IPX4
	Permissible Excessive Operating Pressure for the Discharge Side	MPa	4.3	4.3
	Permissible Excessive Operating Pressure for the Suction Side	MPa	2.5	2.5
	Sound Pressure Level (H/M/L)	dB (A)	52/-/-	52/-/-
	Sound Power Level (H/M/L)	dB (A)	61/-/-	61/-/-
Dimension(WXHxD)	mm	782X540X320	782X540X320	
Dimension of Carton Box (LXWXH)	mm	820X355X580	820X355X580	
Dimension of Package(LXWXH)	mm	823X358X595	823X358X595	
Net Weight	kg	29.5	29.5	
Gross Weight	kg	32	32	
Refrigerant		R32	R32	
Refrigerant Charge	kg	0.6	0.6	
Connection Pipe	Connection Pipe Length	m	5	5
	Connection Pipe Gas Additional Charge	g/m	16	16
	Outer Diameter Liquid Pipe	mm	Φ6	Φ6
	Outer Diameter Gas Pipe	mm	Φ9.52	Φ9.52
	Max Distance Height	m	10	10
	Max Distance Length	m	15	19
Note: The connection pipe applies metric diameter.				

The above data is subject to change without notice. Please refer to the nameplate of the unit.

Parameter		Unit	Value	
Model			1.GWH12QC-K6DNA1C 2.GWH12QC-K6DND4C 3.GWH12QC-K6DNE6C 4.GWH12QC-K6DNC8C 5.GWH12QC-K6DNB2C 6.GWH12QC-K6DNB4C 7.GWH12QC-K6DNB6C 8.GWH12QC-K6DNC2C	GWH12QC-K6DNA3C
Product Code			1.CB419012300 2.CB464000200 3.CB465000500 4.CB456003200 5.CB432014802 6.(CB434012000/CB434012001) 7.CB435007300 8.CB439009403	CB424005200
Power Supply	Rated Voltage	V~	220-240	220-240
	Rated Frequency	Hz	50	50
	Phases		1	1
Power Supply Mode			Outdoor	Outdoor
Cooling Capacity(Min~Max)		W	3500(800~3700)	3500(800~3700)
Heating Capacity(Min~Max)		W	3670(900~380)	3670(900~380)
Cooling Power Input(Min~Max)		W	1085(220~1400)	1085(220~1400)
Heating Power Input(Min~Max)		W	990(220~1500)	990(220~1500)
Cooling Current Input		A	5.0	5.0
Heating Current Input		A	4.5	4.5
Rated Input		W	1500	1500
Rated Current		A	7.2	7.2
Air Flow Volume(SH/H/M//L/SL)		m ³ /h	680/590/490/420/-	680/590/490/420/-
Dehumidifying Volume		L/h	1.4	1.4
EER		W/W	3.26	3.26
COP		W/W	3.71	3.71
SEER		W/W	6.1	6.1
SCOP(Average/Warmer/Colder)		W/W	4.0/5.1/3.4	4.0/5.1/3.4
Application Area		m ²	16-24	16-24
Indoor Unit	Indoor Unit Model		1.GWH12QC-K6DNA1C/I 2.GWH12QC-K6DND4C/I 3.GWH12QC-K6DNE6C/I 4.GWH12QC-K6DNC8C/I 5.GWH12QC-K6DNB2C/I 6.GWH12QC-K6DNB4C/I 7.GWH12QC-K6DNB6C/I 8.GWH12QC-K6DNC2C/I	GWH12QC-K6DNA3C/I
	Indoor Unit Product Code		1.CB419N12300 2.CB464N00200 3.CB465N00500 4.CB456N03200 5.CB432N14801 6.(CB434N12000/CB434012001) 7.CB435N07300 8.CB439N09403	CB424N05200
	Fan Type		Cross-flow	Cross-flow
	Fan Diameter Length(DXL)	mm	Φ98X633.5	Φ98X633.5
	Cooling Speed(SH/H/M//L/SL)	r/min	1350/1200/1050/850/-	1350/1200/1050/850/-
	Heating Speed(SH/H/M//L/SL)	r/min	1300/1150/1000/900/-	1300/1150/1000/900/-
	Fan Motor Power Output	W	20	20
	Fan Motor RLA	A	0.31	0.31
	Fan Motor Capacitor	μF	1.5	1.5
	Evaporator Form		Aluminum Fin-copper Tube	Aluminum Fin-copper Tube
	Evaporator Pipe Diameter	mm	Φ5	Φ5
	Evaporator Row-fin Gap	mm	2-1.5	2-1.5
	Evaporator Coil Length (LXD _X W)	mm	635X22.8X306.3	635X22.8X306.3
	Swing Motor Model		MP24BA	MP24BA
	Swing Motor Power Output	W	2	2
	Fuse Current	A	3.15	3.15
	Sound Pressure Level(SH/H/M//L/SL)	dB (A)	42/38/34/31/-	42/38/34/31/-
	Sound Power Level(SH/H/M//L/SL)	dB (A)	56/52/48/45/-	56/52/48/45/-
	Dimension (WXHXD)	mm	845X289X209	845X289X209
	Dimension of Carton Box (LXWXH)	mm	918X278X364	918X278X364
Dimension of Package(LXWXH)	mm	921X281X379	921X281X379	
Net Weight	kg	10.5	10.5	
Gross Weight	kg	12.5	13	

Outdoor Unit	Outdoor Unit Model		GWH12QC-K6DNA1C/O	
	Outdoor Unit Product Code		CB419W12300	
	Compressor Manufacturer		ZHUHAI LANDA COMPRESSOR CO., LTD	
	Compressor Model		QXF-B096zE190A	
	Compressor Oil		FW68DA	
	Compressor Type		Rotary	
	Compressor LRA.	A		20
	Compressor RLA	A		4.21
	Compressor Power Input	W		943
	Compressor Overload Protector			1NT11L-6233 HPC115/95U1 KSD115°C
	Throttling Method			Capillary
	Set Temperature Range	°C		16~30
	Cooling Operation Ambient Temperature Range	°C		-15~43
	Heating Operation Ambient Temperature Range	°C		-15~24
	Condenser Form			Aluminum Fin-copper Tube
	Condenser Pipe Diameter	mm		Φ7.94
	Condenser Rows-fin Gap	mm		1-1.4
	Condenser Coil Length (LXDXW)	mm		731X19.05X550
	Fan Motor Speed	rpm		900
	Fan Motor Power Output	W		30
	Fan Motor RLA	A		0.36
	Fan Motor Capacitor	μF		/
	Outdoor Unit Air Flow Volume	m ³ /h		2200
	Fan Type			Axial-flow
	Fan Diameter	mm		Φ438
	Defrosting Method			Automatic Defrosting
	Climate Type			T1
	Isolation			I
	Moisture Protection			IPX4
	Permissible Excessive Operating Pressure for the Discharge Side	MPa		4.3
	Permissible Excessive Operating Pressure for the Suction Side	MPa		2.5
	Sound Pressure Level (H/M/L)	dB (A)		53/-/-
Sound Power Level (H/M/L)	dB (A)		62/-/-	
Dimension(WXHXD)	mm		848X596X320	
Dimension of Carton Box (LXWXH)	mm		878X360X630	
Dimension of Package(LXWXH)	mm		881X363X645	
Net Weight	kg		31	
Gross Weight	kg		34	
Refrigerant			R32	
Refrigerant Charge	kg		0.7	
Connection Pipe	Connection Pipe Length	m	5	
	Connection Pipe Gas Additional Charge	g/m	16	
	Outer Diameter Liquid Pipe	mm	Φ6	
	Outer Diameter Gas Pipe	mm	Φ9.52	
	Max Distance Height	m	10	
	Max Distance Length	m	20	
Note: The connection pipe applies metric diameter.				

The above data is subject to change without notice. Please refer to the nameplate of the unit.

Parameter		Unit	Value		
Model			GWH12QC-K6DNA1C(LCLH) GWH12QC-K6DNB6C GWH12QC-K6DNE4C GWH12QC-K6DND6C GWH12QC-K6DNB2C GWH12QC-K6DNC4C	GWH09QB-K6DNC2C	
Product Code			CB419012301 CB435007301 CB470002101 CB460003501 CB432014801 CB444009301	CB439009202	
Power Supply	Rated Voltage	V~	220-240	220-240	
	Rated Frequency	Hz	50	50	
	Phases		1	1	
Power Supply Mode			Outdoor	Outdoor	
Cooling Capacity(Min~Max)		W	3500(800~3700)	2600(500~3350)	
Heating Capacity(Min~Max)		W	3670(900~380)	2800(500~3500)	
Cooling Power Input(Min~Max)		W	1085(220~1400)	805(160~1400)	
Heating Power Input(Min~Max)		W	990(220~1500)	755(200~1500)	
Cooling Current Input		A	5.0	3.9	
Heating Current Input		A	4.5	3.4	
Rated Input		W	1500	1500	
Rated Current		A	7.2	6.3	
Air Flow Volume(SH/H/M//L/SL)		m ³ /h	680/590/490/420/-	540/490/430/330/-	
Dehumidifying Volume		L/h	1.4	0.8	
EER		W/W	3.26	3.23	
COP		W/W	3.71	3.71	
SEER		W/W	6.1	6.1	
SCOP(Average/Warmer/Colder)		W/W	4.0/5.1/3.4	4.0/5.1/3.2	
Application Area		m ²	16-24	12-18	
Indoor Unit	Indoor Unit Model		GWH12QC-K6DNA1C/I GWH12QC-K6DNB6C/I GWH12QC-K6DNE4C/I GWH12QC-K6DND6C/I GWH12QC-K6DNB2C/I GWH12QC-K6DNC4C/I	GWH09QB-K6DNC2C/I	
	Indoor Unit Product Code		CB419N12300 CB435N07300 CB470N02100 CB460N03500 CB432N14800 CB444N09300	CB439N09200	
	Fan Type		Cross-flow	Cross-flow	
	Fan Diameter Length(DXL)		mm	Φ98X633.5	Φ98X580
	Cooling Speed(SH/H/M//L/SL)		r/min	1350/1200/1050/850/-	1300/1200/1050/800/-
	Heating Speed(SH/H/M//L/SL)		r/min	1300/1150/1000/900/-	1300/1200/1050/900/-
	Fan Motor Power Output		W	20	20
	Fan Motor RLA		A	0.31	0.215
	Fan Motor Capacitor		μF	1.5	1
	Evaporator Form			Aluminum Fin-copper Tube	Aluminum Fin-copper Tube
	Evaporator Pipe Diameter		mm	Φ5	Φ5
	Evaporator Row-fin Gap		mm	2-1.5	2-1.4
	Evaporator Coil Length (LXDXW)		mm	635X22.8X306.3	584X22.8X266.7
	Swing Motor Model			MP24BA	MP24AA
	Swing Motor Power Output		W	2	1.5
	Fuse Current		A	3.15	3.15
	Sound Pressure Level(SH/H/M//L/SL)		dB (A)	42/38/34/31/-	39/36/32/28/-
	Sound Power Level(SH/H/M//L/SL)		dB (A)	56/52/48/45/-	55/52/44/38/-
	Dimension (WXHXD)		mm	845X289X209	790X275X200
	Dimension of Carton Box (LXWXH)		mm	918X278X364	863X268X352
Dimension of Package(LXWXH)		mm	921X281X379	866X271X367	
Net Weight		kg	10.5	9	
Gross Weight		kg	12.5	11	

Outdoor Unit	Outdoor Unit Model		GWH12QC-K6DNA1C/O(LCLH)	GWH09QB-K6DNA1C/O
	Outdoor Unit Product Code		CB419W12301	CB419W11902
	Compressor Manufacturer		ZHUHAI LANDA COMPRESSOR CO., LTD	ZHUHAI LANDA COMPRESSOR CO., LTD
	Compressor Model		QXF-B096zE190A	QXF-B096zE190A
	Compressor Oil		FW68DA	FW68DA
	Compressor Type		Rotary	Rotary
	Compressor LRA.	A	20	20
	Compressor RLA	A	4.21	4.21
	Compressor Power Input	W	943	943
	Compressor Overload Protector		1NT11L-6233 HPC115/95U1 KSD115°C	1NT11L-6233 HPC115/95U1 KSD115°C
	Throttling Method		Capillary	Capillary
	Set Temperature Range	°C	16~30	16~30
	Cooling Operation Ambient Temperature Range	°C	-22~43	-15~43
	Heating Operation Ambient Temperature Range	°C	-20~24	-15~24
	Condenser Form		Aluminum Fin-copper Tube	Aluminum Fin-copper Tube
	Condenser Pipe Diameter	mm	Φ7.94	Φ7
	Condenser Rows-fin Gap	mm	1-1.4	1-1.4
	Condenser Coil Length (LXDXW)	mm	731X19.05X550	710X19.05X508
	Fan Motor Speed	rpm	900	900
	Fan Motor Power Output	W	30	30
	Fan Motor RLA	A	0.36	0.36
	Fan Motor Capacitor	μF	/	/
	Outdoor Unit Air Flow Volume	m ³ /h	2200	1600
	Fan Type		Axial-flow	Axial-flow
	Fan Diameter	mm	Φ438	Φ400
	Defrosting Method		Automatic Defrosting	Automatic Defrosting
	Climate Type		T1	T1
	Isolation		I	I
	Moisture Protection		IPX4	IPX4
	Permissible Excessive Operating Pressure for the Discharge Side	MPa	4.3	4.3
	Permissible Excessive Operating Pressure for the Suction Side	MPa	2.5	2.5
	Sound Pressure Level (H/M/L)	dB (A)	53/-/-	52/-/-
	Sound Power Level (H/M/L)	dB (A)	62/-/-	61/-/-
Dimension(WXHXD)	mm	848X596X320	782X540X320	
Dimension of Carton Box (LXWXH)	mm	878X360X630	820X355X580	
Dimension of Package(LXWXH)	mm	881X363X645	823X358X595	
Net Weight	kg	31	29.5	
Gross Weight	kg	34	32	
Refrigerant		R32	R32	
Refrigerant Charge	kg	0.7	0.6	
Connection Pipe	Connection Pipe Length	m	5	5
	Connection Pipe Gas Additional Charge	g/m	16	16
	Outer Diameter Liquid Pipe	mm	Φ6	Φ6
	Outer Diameter Gas Pipe	mm	Φ9.52	Φ9.52
	Max Distance Height	m	10	10
	Max Distance Length	m	20	19
Note: The connection pipe applies metric diameter.				

The above data is subject to change without notice. Please refer to the nameplate of the unit.

Parameter		Unit	Value	
Model			GWH18QD-K6DNC8C	GWH18QD-K6DNB4B GWH18QD-K6DNA1B GWH18QD-K6DND6B GWH18QD-K6DNA5B GWH18QD-K6DND8B GWH18QD-K6DND8B
Product Code			CB456003400	CB434011200/CB434011201 CB419015200 CB460005301 CB425011900 CB459005200 CB459005200
Power Supply	Rated Voltage	V~	220-240	220-240
	Rated Frequency	Hz	50	50
	Phases		1	1
Power Supply Mode			Outdoor	Outdoor
Cooling Capacity(Min~Max)		W	5130(1200~6200)	4600
Heating Capacity(Min~Max)		W	5280(1200~6600)	5200
Cooling Power Input(Min~Max)		W	1580(350~2100)	1430
Heating Power Input(Min~Max)		W	1420(350~2300)	1400
Cooling Current Input		A	7.0	6.3
Heating Current Input		A	6.3	6.2
Rated Input		W	2300	1700
Rated Current		A	10.8	8
Air Flow Volume(SH/H/M//L/SL)		m ³ /h	850/720/610/520/-	850/720/610/520/-
Dehumidifying Volume		L/h	1.8	1.8
EER		W/W	3.25	3.22
COP		W/W	3.72	3.71
SEER		W/W	6.1	6.1
SCOP(Average/Warmer/Colder)		W/W	4.0/5.1/3.4	/
Application Area		m ²	23-34	21-31
Indoor Unit	Indoor Unit Model		GWH18QD-K6DNC8C/I	GWH18QD-K6DNB4B/I GWH18QD-K6DNA1B/I GWH18QD-K6DND6B/I GWH18QD-K6DNA5B/I GWH18QD-K6DND8B/I GWH18QD-K6DND8B/I
	Indoor Unit Product Code		CB456N03400	CB434N11200/CB434N11201 CB419N15200 CB460N05301 CB425N11900 CB459N05200 CB459N05200
	Fan Type		Cross-flow	Cross-flow
	Fan Diameter Length(DXL)	mm	Φ106X706	Φ106X706
	Cooling Speed(SH/H/M//L/SL)	r/min	1230/1130/1030/800/-	1230/1130/1030/800/-
	Heating Speed(SH/H/M//L/SL)	r/min	1350/1200/1050/900/-	1350/1200/1050/900/-
	Fan Motor Power Output	W	35	/
	Fan Motor RLA	A	0.35	0.35
	Fan Motor Capacitor	μF	2.5	2.5
	Evaporator Form		Aluminum Fin-copper Tube	Aluminum Fin-copper Tube
	Evaporator Pipe Diameter	mm	Φ7	Φ7
	Evaporator Row-fin Gap	mm	2-1.4	2-1.4
	Evaporator Coil Length (LXDXW)	mm	715X25.4X304.8	715X25.4X304.8
	Swing Motor Model		MP35CJ	MP35CP
	Swing Motor Power Output	W	2.5	2.5
	Fuse Current	A	3.15	3.15
	Sound Pressure Level(SH/H/M//L/SL)	dB (A)	49/44/39/34/-	49/45/41/36/-
	Sound Power Level(SH/H/M//L/SL)	dB (A)	59/54/49/44/-	58/55/51/46/-
	Dimension (WXHXD)	mm	970X300X224	970X300X224
	Dimension of Carton Box (LXWXH)	mm	1038X380X305	1038X380X305
Dimension of Package(LXWXH)	mm	1041X383X320	1041X383X320	
Net Weight	kg	13.5	13.5	
Gross Weight	kg	16.5	16.5	

Outdoor Unit	Outdoor Unit Model		GWH18QD-K6DNA1C/O	GWH18AAD-K6DNA1B/O
	Outdoor Unit Product Code		CB419W12500	CB476W00600
	Compressor Manufacturer		ZHUHAI LANDA COMPRESSOR CO.,LTD	ZHUHAI LANDA COMPRESSOR CO., LTD
	Compressor Model		QXF-B141ZF030A	QXF-B096zE190A
	Compressor Oil		68EP	FW68DA
	Compressor Type		Rotary	Rotary
	Compressor LRA.	A	25	16.5
	Compressor RLA	A	6.5	4.21
	Compressor Power Input	W	1410	943
	Compressor Overload Protector		1NT11L-6233/KSD115°C /HPC 115/95	/
	Throttling Method		Electron expansion valve	Capillary
	Set Temperature Range	°C	16~30	16~30
	Cooling Operation Ambient Temperature Range	°C	-15~43	-15~43
	Heating Operation Ambient Temperature Range	°C	-15~24	-15~24
	Condenser Form		Aluminum Fin-copper Tube	Aluminum Fin-copper Tube
	Condenser Pipe Diameter	mm	Φ7.94	Φ7
	Condenser Rows-fin Gap	mm	2-1.4	2-1.4
	Condenser Coil Length (LXD _X W)	mm	742X38.1X550	742X38.1X550
	Fan Motor Speed	rpm	780	900
	Fan Motor Power Output	W	40	30
	Fan Motor RLA	A	0.62	0.4
	Fan Motor Capacitor	μF	/	/
	Outdoor Unit Air Flow Volume	m ³ /h	2400	2200
	Fan Type		Axial-flow	Axial-flow
	Fan Diameter	mm	Φ445	Φ438
	Defrosting Method		Automatic Defrosting	Automatic Defrosting
	Climate Type		T1	T1
	Isolation		I	I
	Moisture Protection		IPX4	IPX4
	Permissible Excessive Operating Pressure for the Discharge Side	MPa	4.3	4.3
	Permissible Excessive Operating Pressure for the Suction Side	MPa	2.5	2.5
	Sound Pressure Level (H/M/L)	dB (A)	56/-/-	54/-/-
Sound Power Level (H/M/L)	dB (A)	64/-/-	64/-/-	
Dimension(WXHXD)	mm	899X596X378	848X596X320	
Dimension of Carton Box (LXWXH)	mm	945X417X630	878X360X630	
Dimension of Package(LXWXH)	mm	948X420X645	881X363X645	
Net Weight	kg	39	34	
Gross Weight	kg	42	37	
Refrigerant		R32	R32	
Refrigerant Charge	kg	0.9	0.77	
Connection Pipe	Connection Pipe Length	m	5	5
	Connection Pipe Gas Additional Charge	g/m	16	16
	Outer Diameter Liquid Pipe	mm	Φ6	Φ6
	Outer Diameter Gas Pipe	mm	Φ12	Φ9.52
	Max Distance Height	m	10	10
	Max Distance Length	m	25	20
	Note: The connection pipe applies metric diameter.			

The above data is subject to change without notice. Please refer to the nameplate of the unit.

Model			GWH12QB-K6DNC4I GWH12QB-K6DNE4I GWH12QB-K6DNE4I GWH12QB-K6DNC2I GWH12QB-K6DNA6I	
Product Code			CB444007500 CB470002300 CB470002301 CB439012700/CB439012701 CB427010300	
Power Supply	Rated Voltage	V~	220-240	
	Rated Frequency	Hz	50	
	Phases		1	
Power Supply Mode			Outdoor	
Cooling Capacity(Min~Max)		W	3200 (600~3600)	
Heating Capacity(Min~Max)		W	3500 (600~3800)	
Cooling Power Input(Min~Max)		W	997 (120~1400)	
Heating Power Input(Min~Max)		W	970 (120~1500)	
Cooling Current Input		A	4.42	
Heating Current Input		A	4.30	
Rated Input		W	1500	
Rated Current		A	6.21	
Air Flow Volume(SH/H/M/L/SL)		m ³ /h	560/330/480/282/-	
Dehumidifying Volume		L/h	1.4	
EER		W/W	3.21	
COP		W/W	3.61	
SEER			6.10	
SCOP(Average/Warmer/Colder)			4	
HSPF			/	
Application Area		m ²	12-18	
Indoor Unit	Indoor Unit Model		GWH12QB-K6DNC4I/I GWH12QB-K6DNE4I/I GWH12QB-K6DNE4I/I GWH12QB-K6DNC2I/I GWH12QB-K6DNA6I/I	
	Indoor Unit Product Code		CB444N07500 CB470N02300 CB470N02301 CB439N12700/CB439N12701 CB427N10300	
	Fan Type		Cross-flow	
	Fan Diameter Length(DXL)		mm	Φ98X580
	Cooling Speed(SH/H/M/L/SL)		r/min	1350/1200/1050/750/-
	Heating Speed(SH/H/M/L/SL)		r/min	1350/1200/1050/850/-
	Fan Motor Power Output		W	20
	Fan Motor RLA		A	0.215
	Fan Motor Capacitor		μF	1
	Evaporator Form			Aluminum Fin-copper Tube
	Evaporator Pipe Diameter		mm	Φ5
	Evaporator Row-fin Gap		mm	2-1.4
	Evaporator Coil Length(LXDXW)		mm	584X22.8X266.7
	Swing Motor Model			MP24AA
	Swing Motor Power Output		W	1.5
	Fuse Current		A	3.15
	Sound Pressure Level(SH/H/M/L/SL)		dB (A)	42/37/34/28/-
	Sound Power Level(SH/H/M/L/SL)		dB (A)	55/47/44/38/-
	Dimension(WXHXD)		mm	790X275X200
	Dimension of Carton Box(LXWXH)		mm	850X339X262
	Dimension of Package(LXWXH)		mm	852X355X273
Net Weight		kg	9	
Gross Weight		kg	11	

Outdoor Unit	Model of Outdoor Unit		GWH12QB-K6DNB8I/O	
	Product Code of Outdoor Unit		CB438W06800	
	Compressor Manufacturer/Trademark		ZHUHAI LANDA COMPRESSOR CO., LTD	
	Compressor Model		QXF-B096zE190A	
	Compressor Oil		FW68DA	
	Compressor Type		Rotary	
	L.R.A.	A		20.0
	Compressor RLA	A		4.21
	Compressor Power Input	W		943
	Overload Protector			1NT11L-6233
	Throttling Method			Capillary
	Operation temp	°C		16~30
	Ambient temp (cooling)	°C		-15~43
	Ambient temp (heating)	°C		-15~24
	Condenser Form			Aluminum Fin-copper Tube
	Pipe Diameter	mm		Φ7.94
	Rows-fin Gap	mm		1-1.4
	Coil Length (LXD _X W)	mm		731X19.05X550
	Fan Motor Speed	rpm		900
	Output of Fan Motor	W		30
	Fan Motor RLA	A		0.36
	Fan Motor Capacitor	μF		/
	Air Flow Volume of Outdoor Unit	m ³ /h		2200
	Fan Type			Axial-flow
	Fan Diameter	mm		Φ438
	Defrosting Method			Automatic Defrosting
	Climate Type			T1
	Isolation			I
	Moisture Protection			IPX4
	Permissible Excessive Operating Pressure for the Discharge Side	MPa		4.3
	Permissible Excessive Operating Pressure for the Suction Side	MPa		2.5
	Sound Pressure Level (H/M/L)	dB (A)		52/-/-
Sound Power Level (H/M/L)	dB (A)		62/-/-	
Dimension (WXHXD)	mm		848X596X320	
Dimension of Carton Box (LXWXH)	mm		878X360X630	
Dimension of Package (LXWXH)	mm		881X363X645	
Net Weight	kg		31	
Gross Weight	kg		34	
Refrigerant			R32	
Refrigerant Charge	kg		0.59	
Connection Pipe	Length	m	5	
	Gas Additional Charge	g/m	16	
	Outer Diameter Liquid Pipe	mm	Φ6	
	Outer Diameter Gas Pipe	mm	Φ9.52	
	Max Distance Height	m	10	
	Max Distance Length	m	20	
Note: The connection pipe applies metric diameter.				

The above data is subject to change without notice; please refer to the nameplate of the unit.

2.2 Operation Characteristic Curve

Cooling

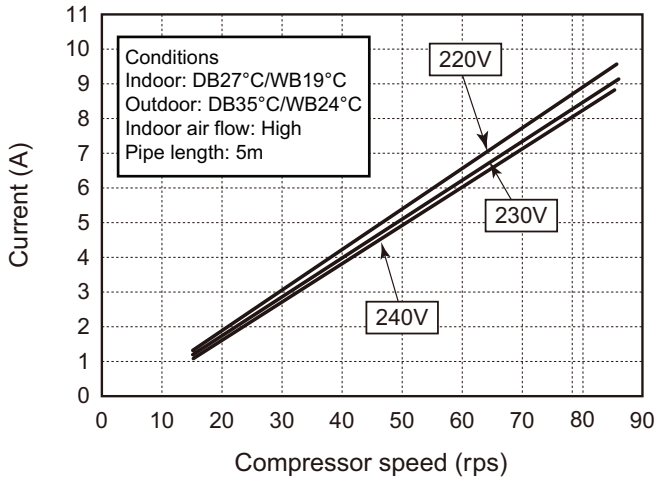

Heating

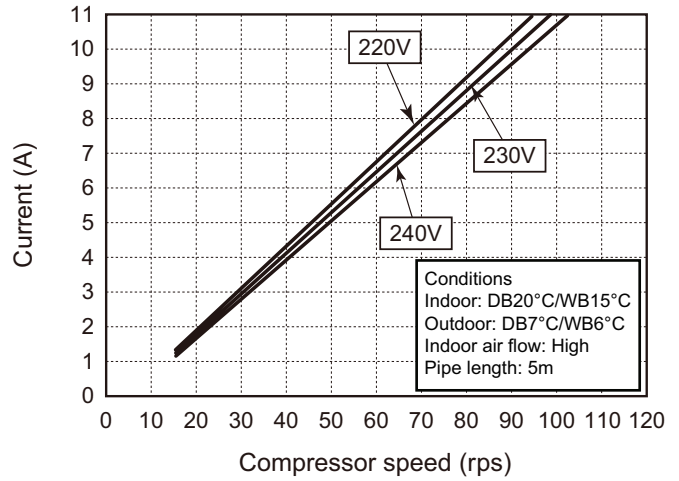

2.3 Capacity Variation Ratio According to Temperature

Heating operation ambient temperature range is -20°C~24°C

Cooling

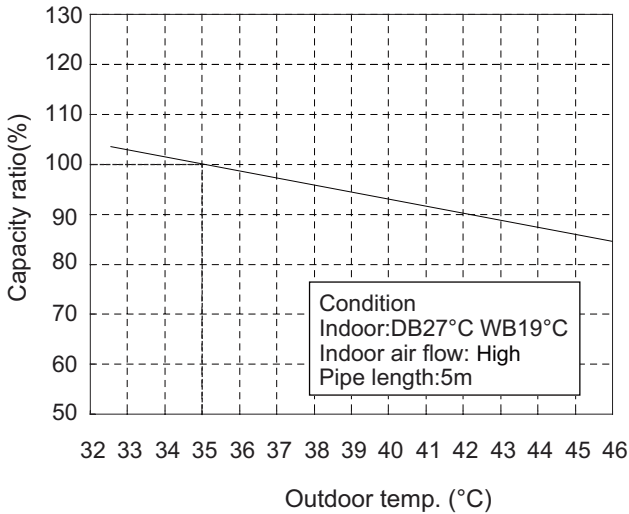

Heating

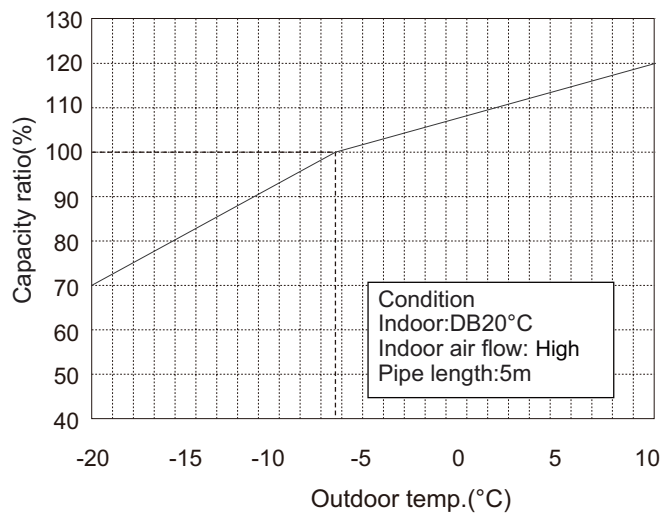

Heating operation ambient temperature range is -15°C~24°C

Cooling

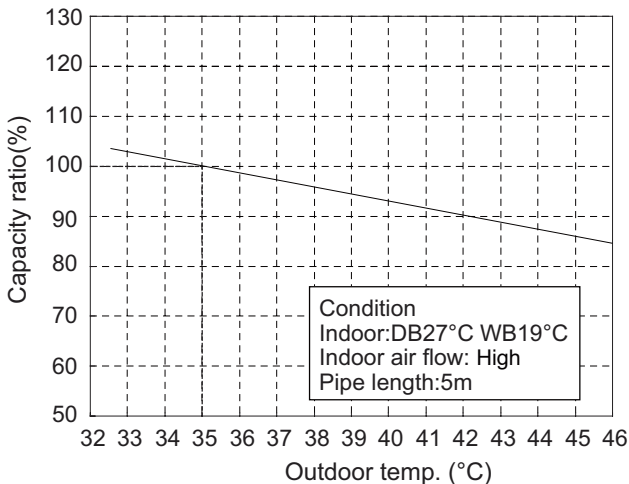

Heating

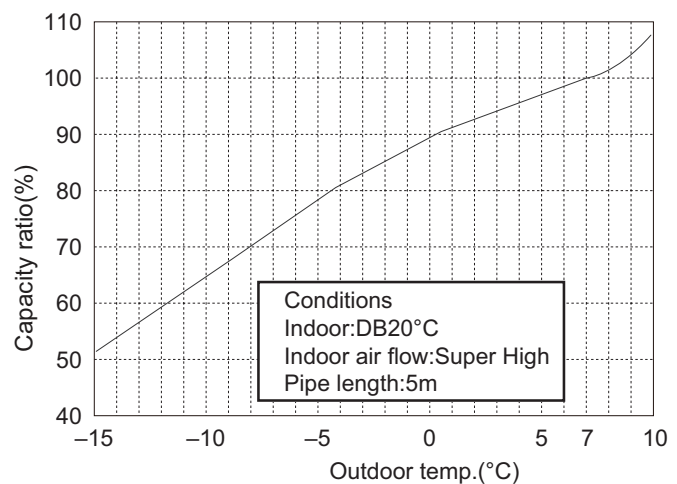

2.4 Cooling and Heating Data Sheet in Rated Frequency

Cooling:

Rated cooling condition(°C) (DB/WB)		Model	Pressure of gas pipe connecting indoor and outdoor unit P (MPa)	Inlet and outlet pipe temperature of heat exchanger		Fan speed of indoor unit	Fan speed of outdoor unit	Compressor revolution (rps)
Indoor	Outdoor			T1 (°C)	T2 (°C)			
27/19	35/24	09K	0.8 ~ 1.1	12 to 15	65 to 38	TURBO	High	49
		12K		11 to 14	64 to 37			60
27/19	35/24	18K	0.9 ~ 1.1	12 to 14	75 to 37	Super High	High	52

Heating:

Rated cooling condition(°C) (DB/WB)		Model	Pressure of gas pipe connecting indoor and outdoor unit P (MPa)	Inlet and outlet pipe temperature of heat exchanger		Fan speed of indoor unit	Fan speed of outdoor unit	Compressor revolution (rps)
Indoor	Outdoor			T1 (°C)	T2 (°C)			
20/-	7/6	09K	2.8 ~ 3.2	35 to 63	2 to 5	TURBO	High	59
		12K		35 to 65	2 to 5			67
20/-	7/6	18K	2.2 ~ 2.4	70 to 35	2 to 4	Super High	High	65

Instruction:

T1: Inlet and outlet pipe temperature of evaporator

T2: Inlet and outlet pipe temperature of condenser

P: Pressure at the side of big valve

Connection pipe length: 5 m.

2.5 Noise Curve

09/12K

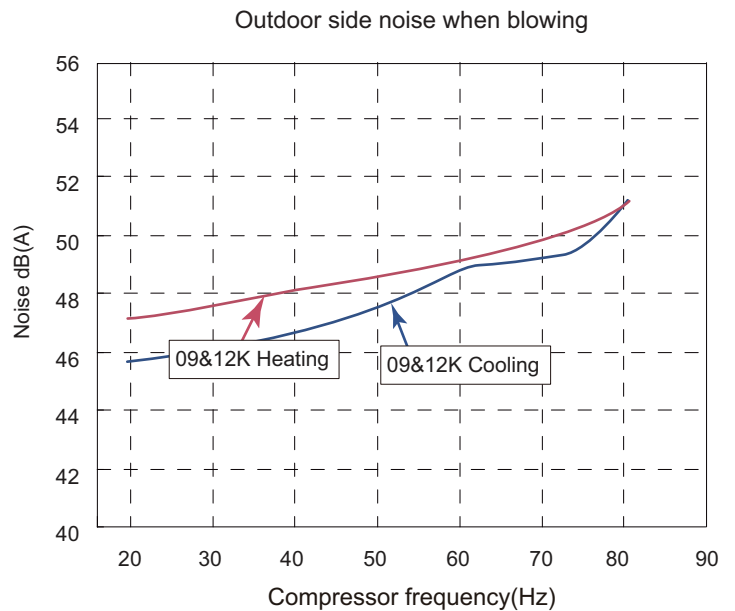
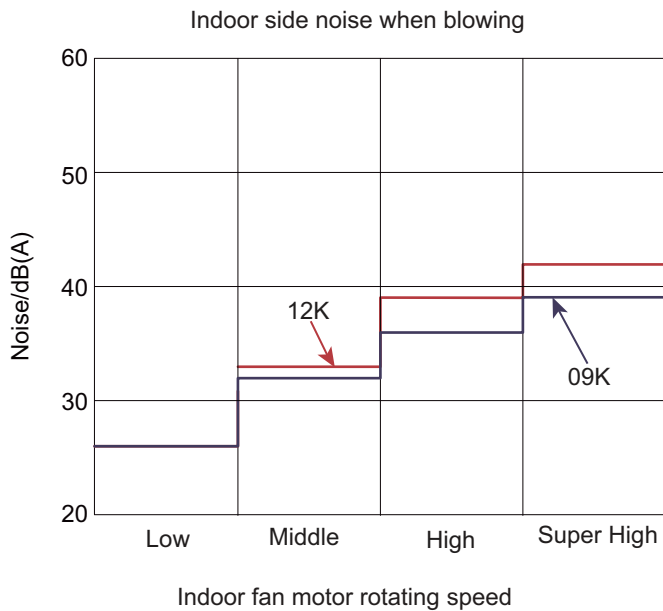

18K

Indoor side noise when blowing

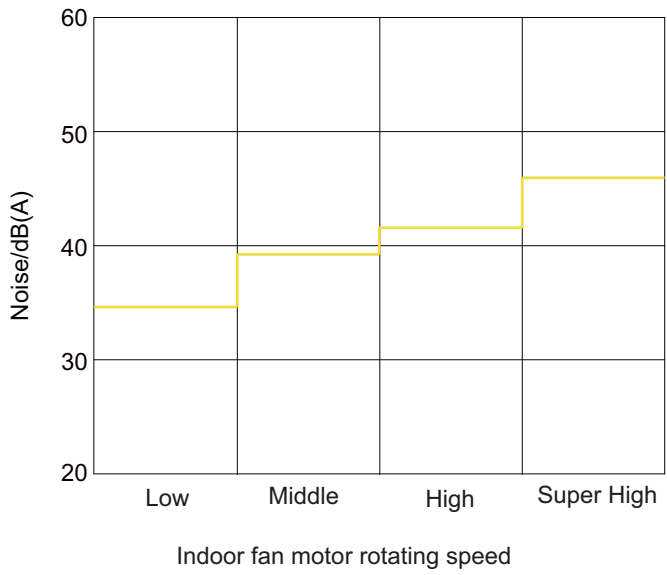

Outdoor side noise when blowing

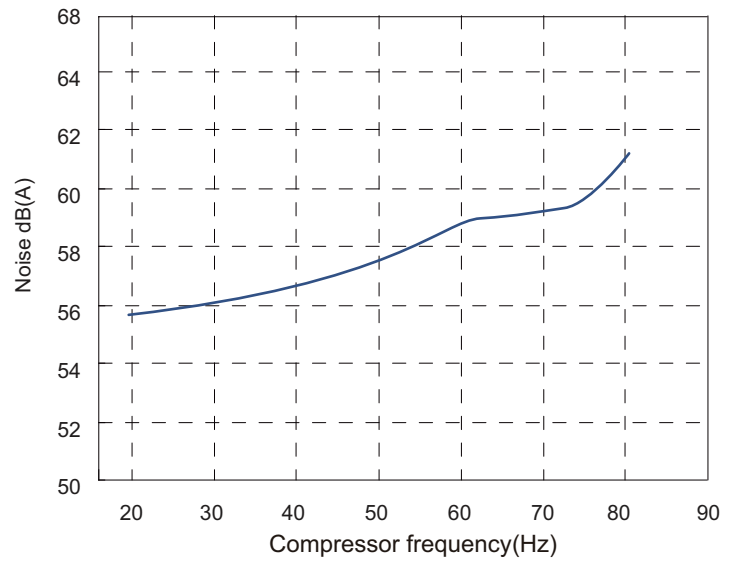

3.2 Outdoor Unit

GWH09QB-K6DNA1C/O

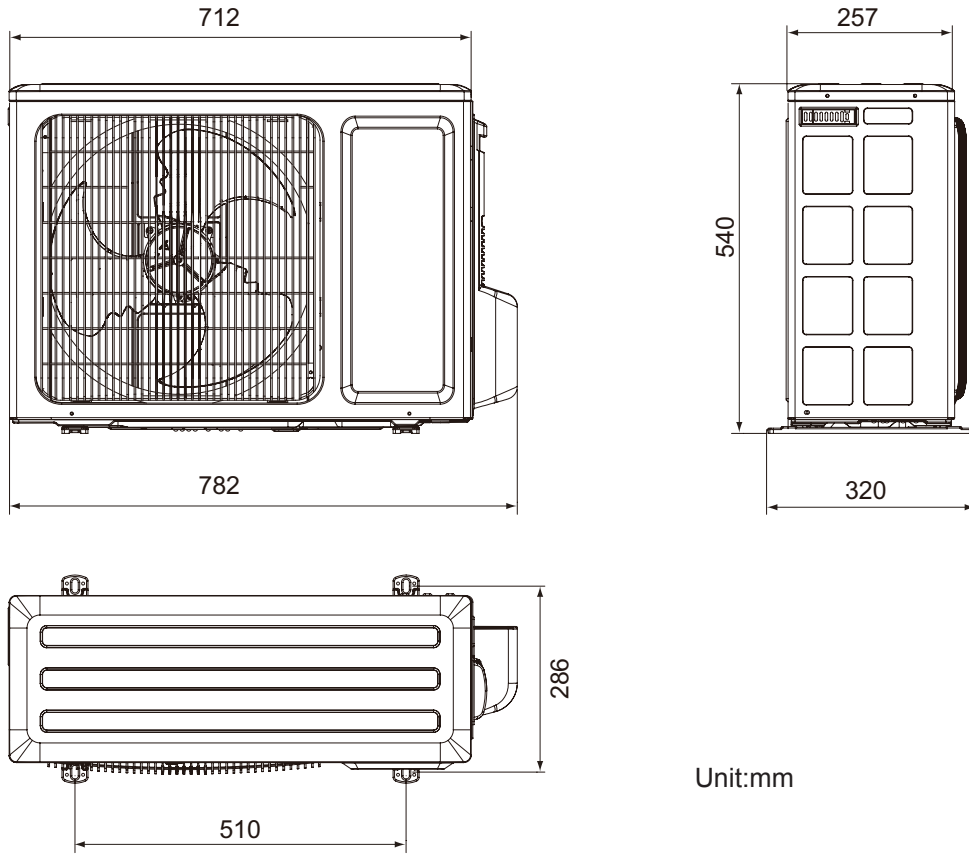

Unit:mm

GWH09QB-K6DNB8I/O

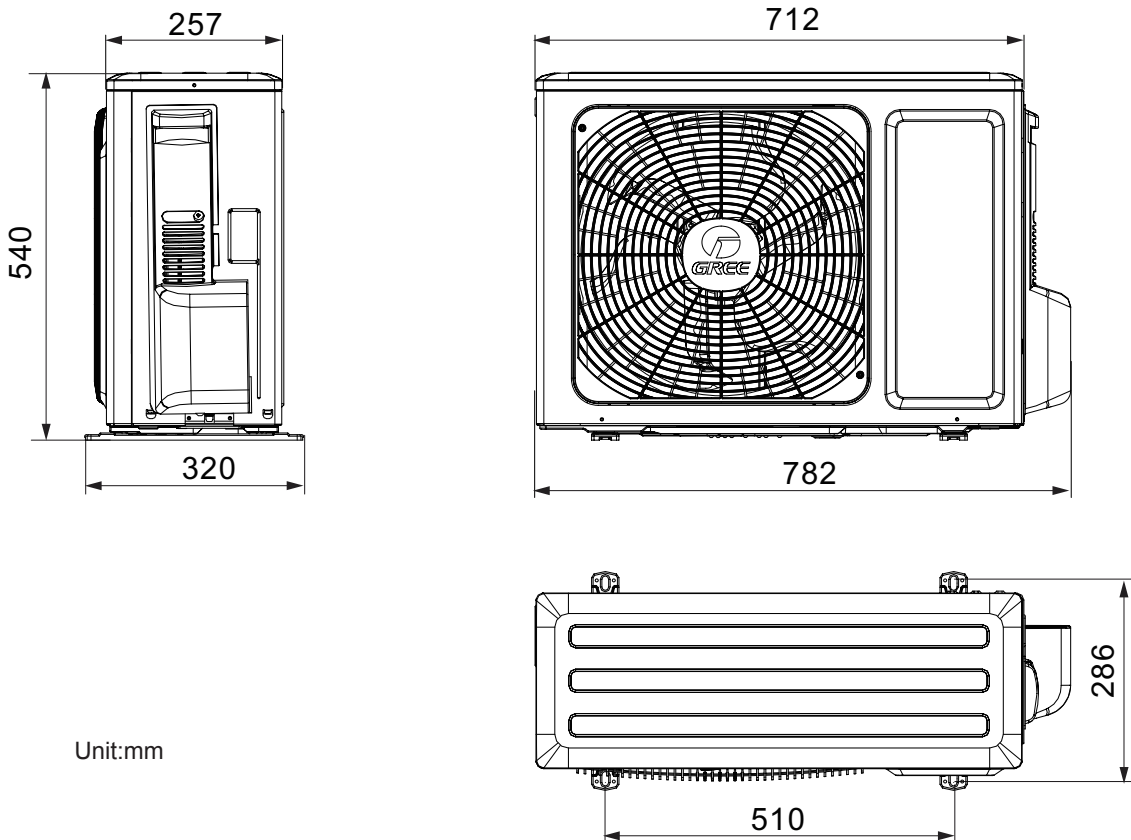

Unit:mm

4. Refrigerant System Diagram

All models except GWH18QD-K6DNC8C

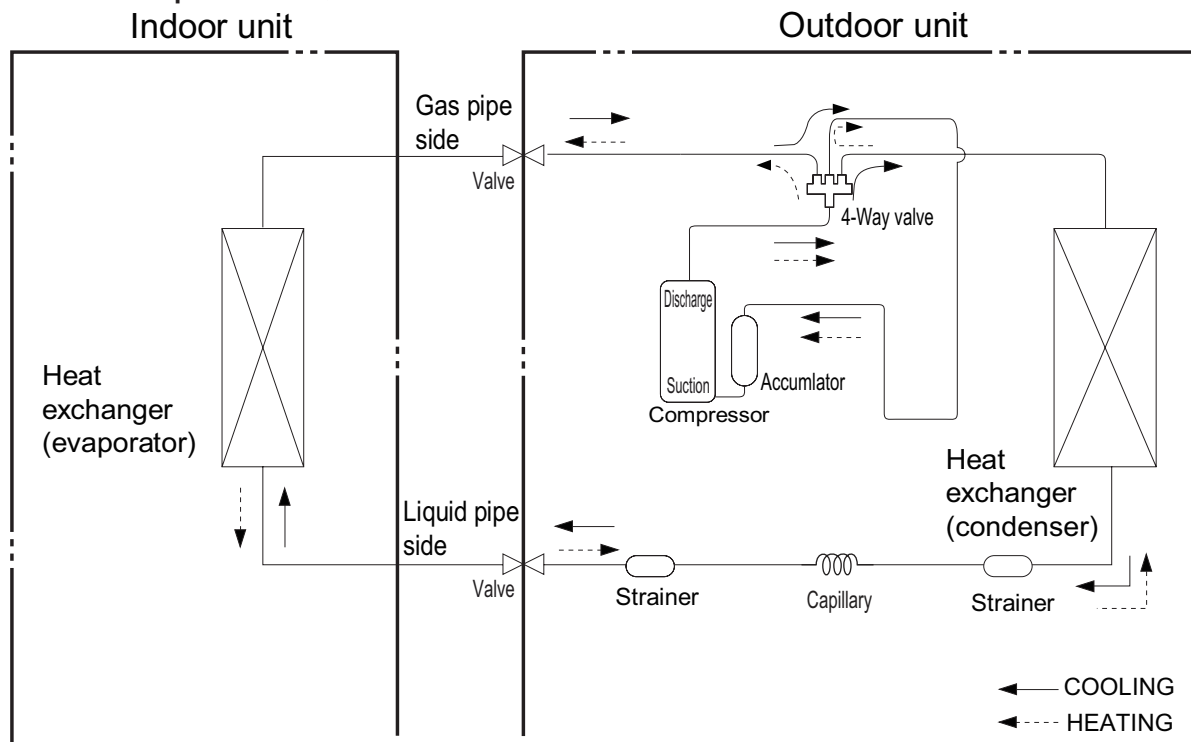

Connection pipe specification:
Liquid pipe: 1/4" (6mm)
Gas pipe: 3/8" (9.52mm)

GWH18QD-K6DNC8C

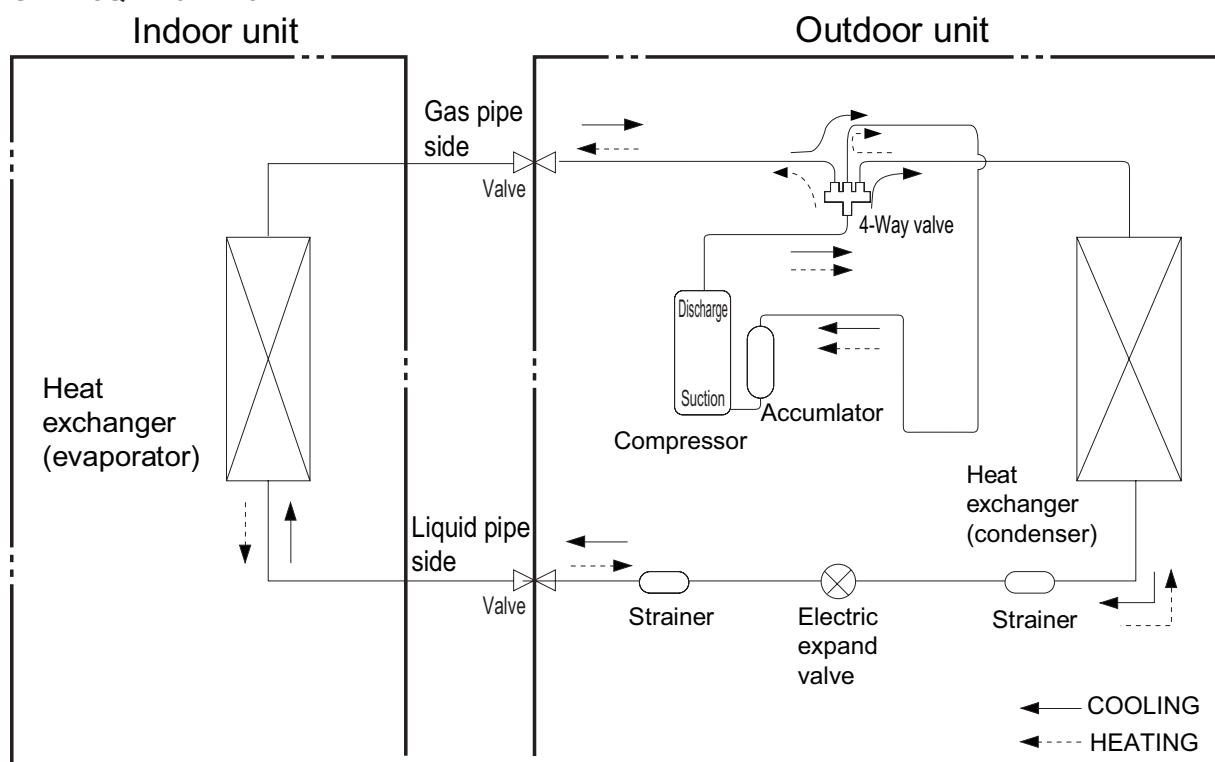

Connection pipe specification:
Liquid pipe: 1/4" (6mm)
Gas pipe: 1/2" (12mm)

5. Electrical Part

5.1 Wiring Diagram

• Instruction

Symbol	Symbol Color	Symbol	Symbol Color	Symbol	Name
WH	White	GN	Green	CAP	Jumper cap
YE	Yellow	BN	Brown	COMP	Compressor
RD	Red	BU	Blue		Grounding wire
YEGN	Yellow/Green	BK	Black	/	/
VT	Violet	OG	Orange	/	/

Note: Jumper cap is used to determine fan speed and the swing angle of horizontal lover for this model.

• Indoor Unit

GWH12QC-K6DNB6C/I GWH09QB-K6DNB6C/I GWH09QB-K6DNB8I/I GWH12QC-K6DNE4C/I(CB470N02100)
 GWH09QB-K6DNB2C/I(CB432N12500) GWH09QB-K6DNE4C/I(CB470N02000) GWH09QB-K6DNB4C/I(CB434N11300)
 GWH09QB-K6DNE6C/I(CB465N00600) GWH09QB-K6DND4C/I(CB464N00300) GWH12QC-K6DND4C/I(CB464N00200)
 GWH09QB-K6DNA1C/I GWH12QC-K6DNA1C/I GWH09QB-K6DNA3C/I GWH12QC-K6DNA3C/I GWH09QB-K6DNC8C/I
 GWH12QC-K6DNC8C/I GWH12QC-K6DNE6C/I GWH09QB-K6DND6C/I GWH18QD-K6DNC8C/I GWH09QB-K6DNC4I/I
 GWH09QB-K6DNE4I/I GWH12QC-K6DND6C/I GWH09QB-K6DNB4I/I GWH12QC-K6DNB2C/I GWH09QB-K6DNC8I/I
 GWH09QB-K6DNA1I/I(CB419N15100) GWH12QC-K6DNB4C/I (CB434N12000) GWH09QB-K6DNC4C/I
 GWH09QB-K6DND6I/I GWH09QB-K6DNA5I/I GWH12QC-K6DNC4C/I GWH09QB-K6DNA3I/I GWH09QB-K6DNC6I/I
 GWH09QB-K6DNC2I/I(CB439N12600) GWH09QB-K6DNA2I/I GWH09QB-K6DNA6I/I GWH09QB-K6DND8I/I

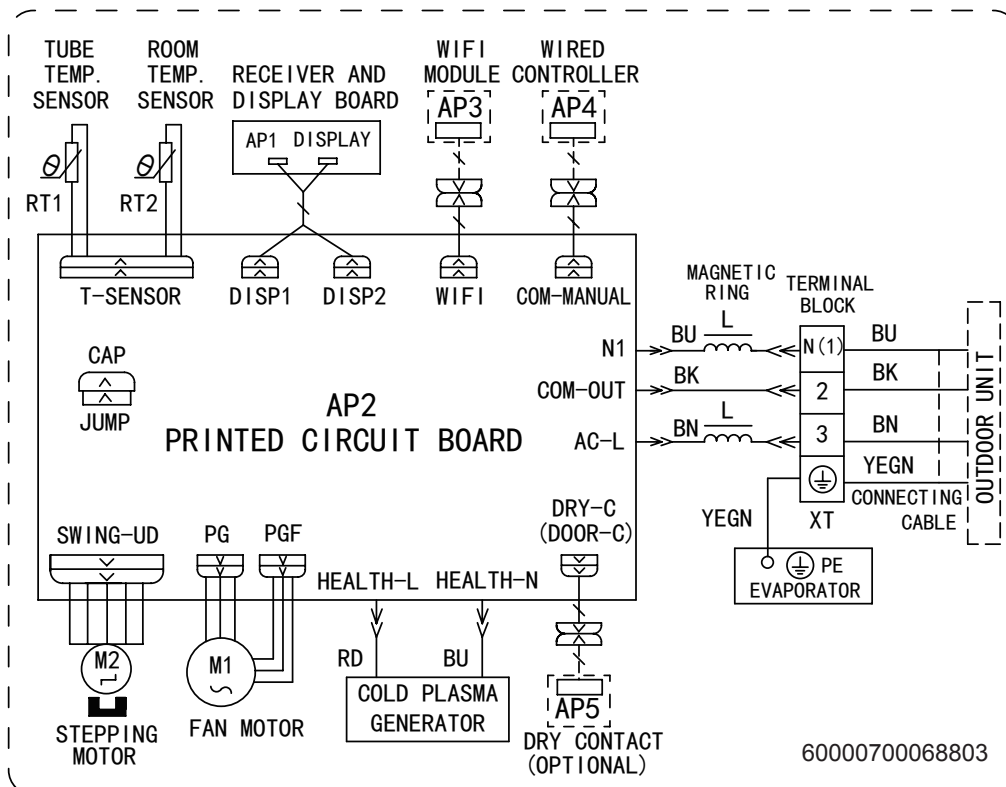

GWH09QB-K6DNE6C/I(CB465N00601) GWH09QB-K6DND4C/I(CB464N00302) GWH09QB-K6DND6C/I(CB460N03002)
 GWH09QB-K6DNB2C/I(CB432N12501) GWH12QC-K6DNB2C/I(CB432N14801) GWH09QB-K6DNB8I/I(CB438N07401)
 GWH09QB-K6DND6I/I(CB460N05601)GWH09QB-K6DNE4I/I(CB470N02201) GWH09QB-K6DNC2C/I(CB439N09201)
 GWH12QC-K6DNC2C/I(CB439N09403) GWH09QB-K6DNB4I/I(CB434N11501) GWH09QB-K6DNB4C/I(CB434N11301)
 GWH12QC-K6DNB4C/I(CB434N12001) GWH09QB-K6DNC2I/I(CB439N12601)

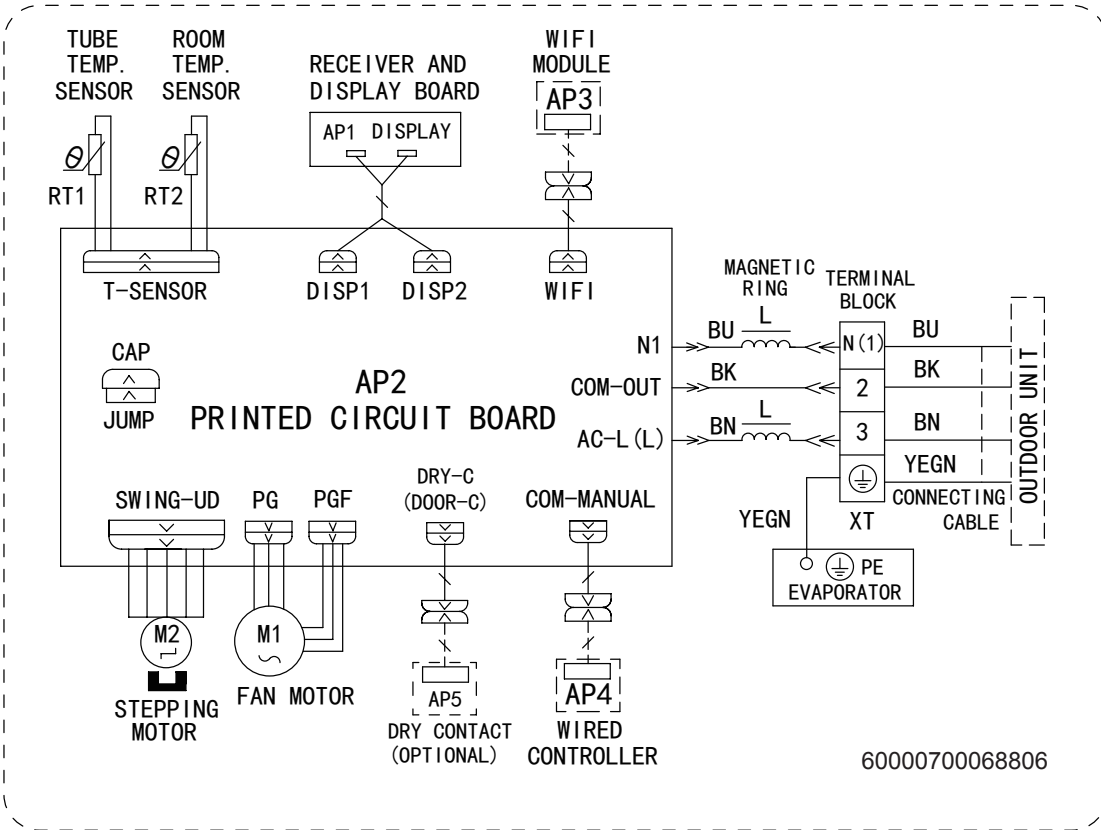

GWH09QB-K6DNC2C/I

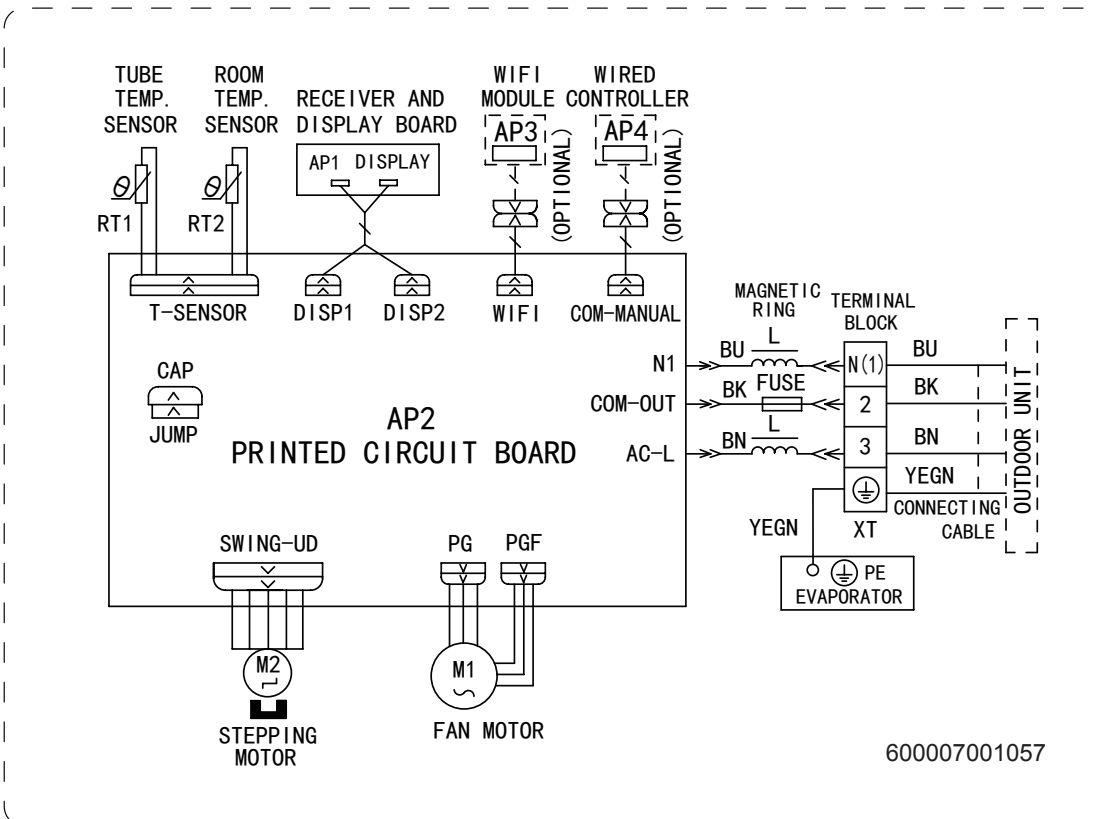

GWH12QB-K6DNC4I/I GWH12QB-K6DNC4I/I GWH12QB-K6DNC2I/I(CB439N12700) GWH12QB-K6DNA6I/I

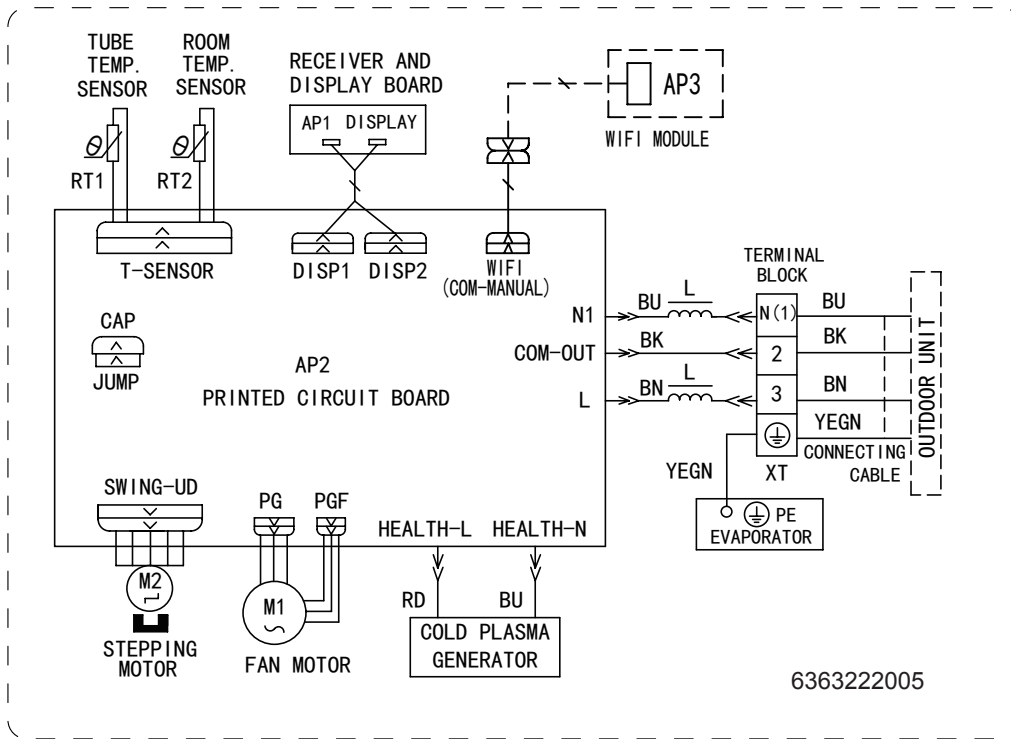

GWH18QD-K6DNB4B/I GWH18QD-K6DNA1B/I GWH18QD-K6DND6B/I GWH18QD-K6DNA5B/I
GWH18QD-K6DND8B/I

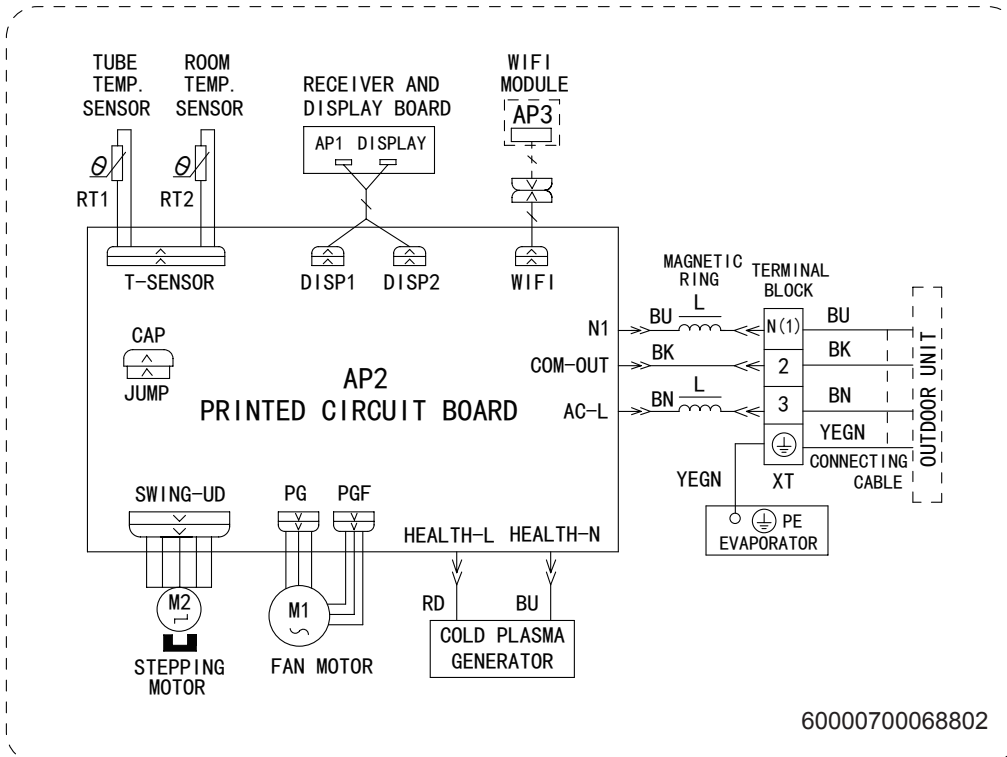

GWH09QB-K6DNA1E/I

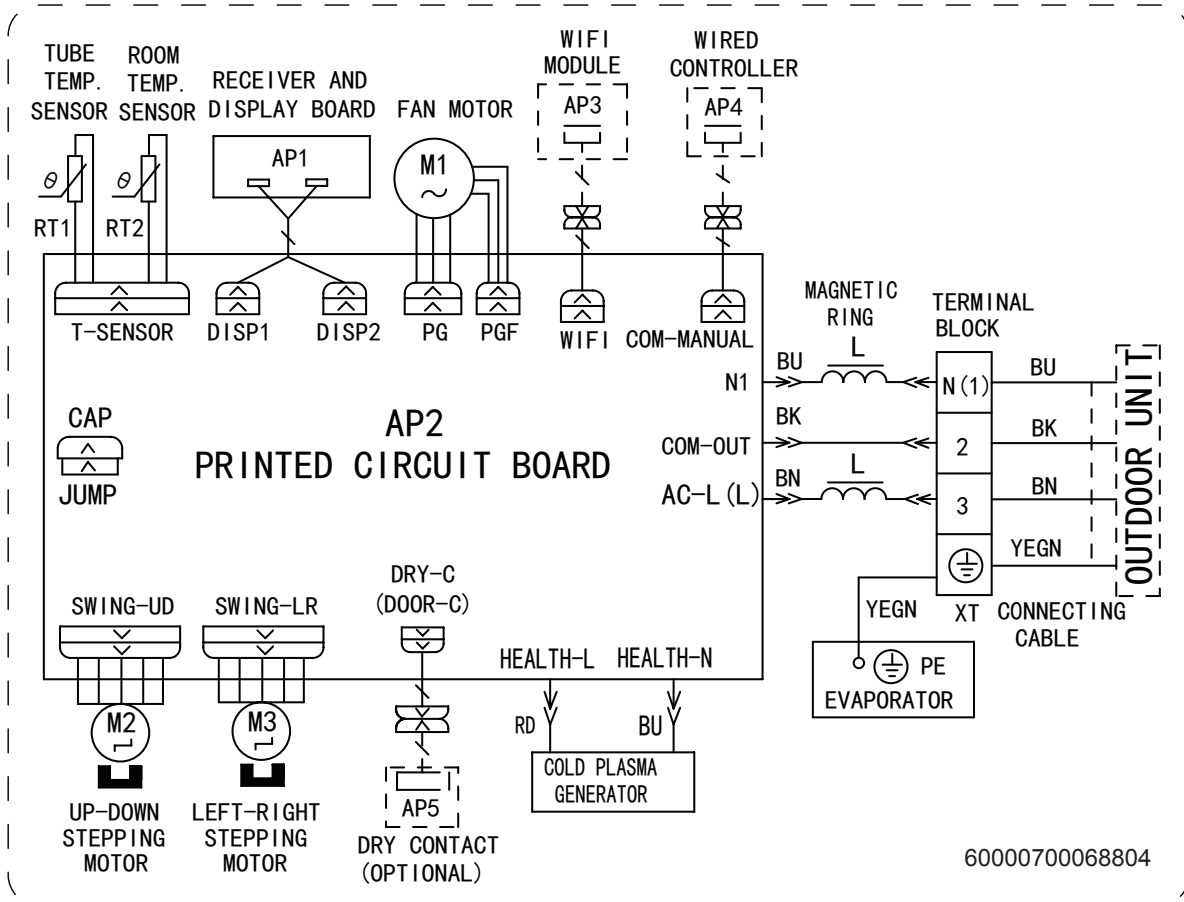

GWH12QB-K6DNE4I/(CB470N02301) GWH12QB-K6DNC2I/(CB439N12701)

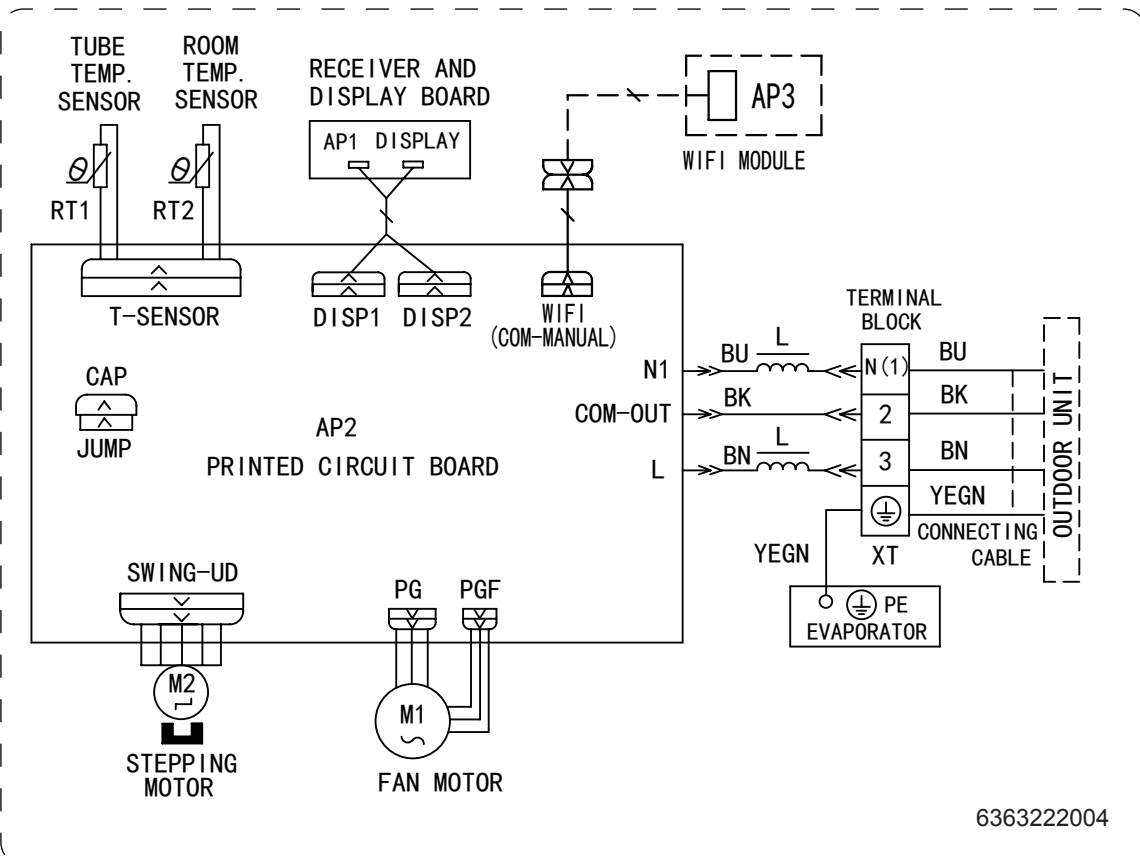

● Outdoor Unit

GWH09QB-K6DNA1C/O(CB419W11900 CB419W11902) GWH09QB-K6DNB8I/O

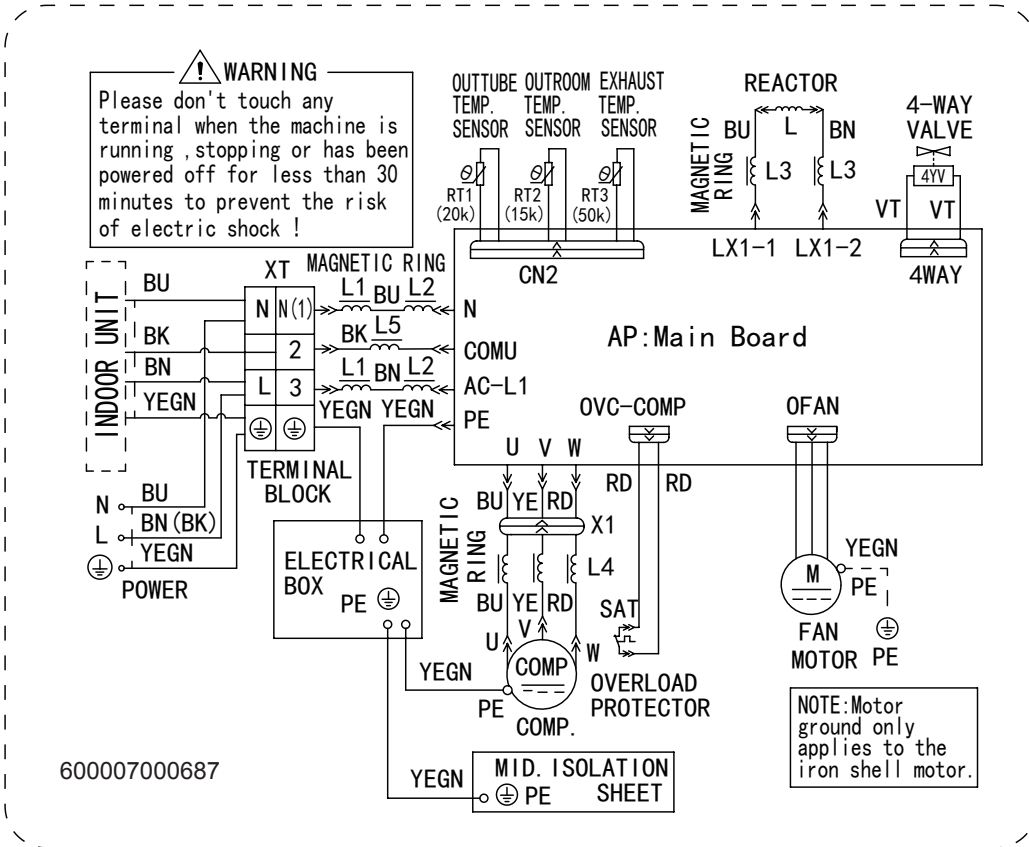

GWH12QC-K6DNA1C/O(CB419W12301)

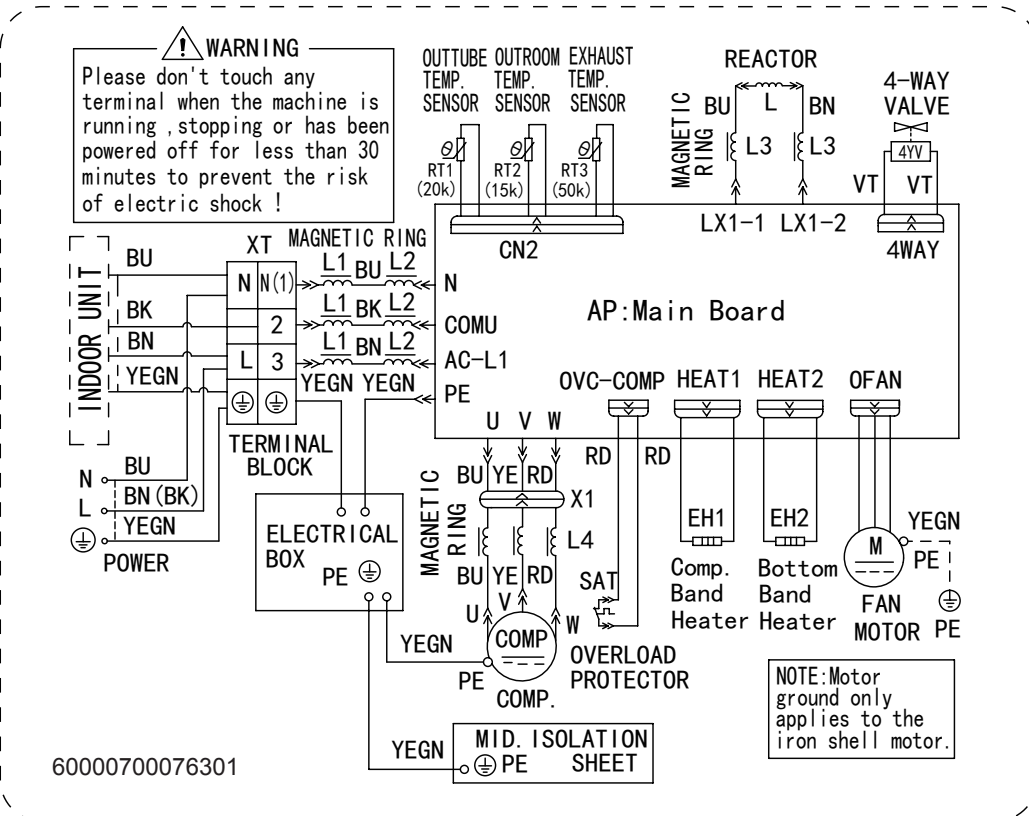

GWH09QB-K6DNA1C/O(CB419W11901)

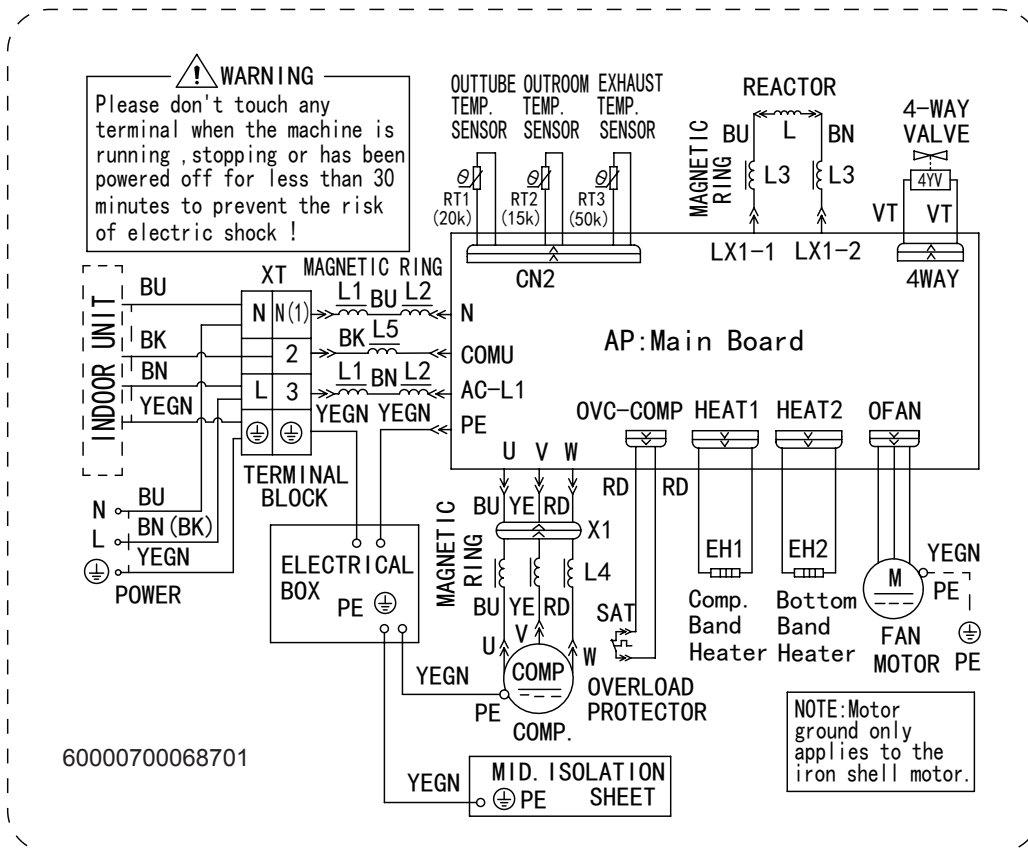

GWH12QC-K6DNA1C/O(CB419W12300)

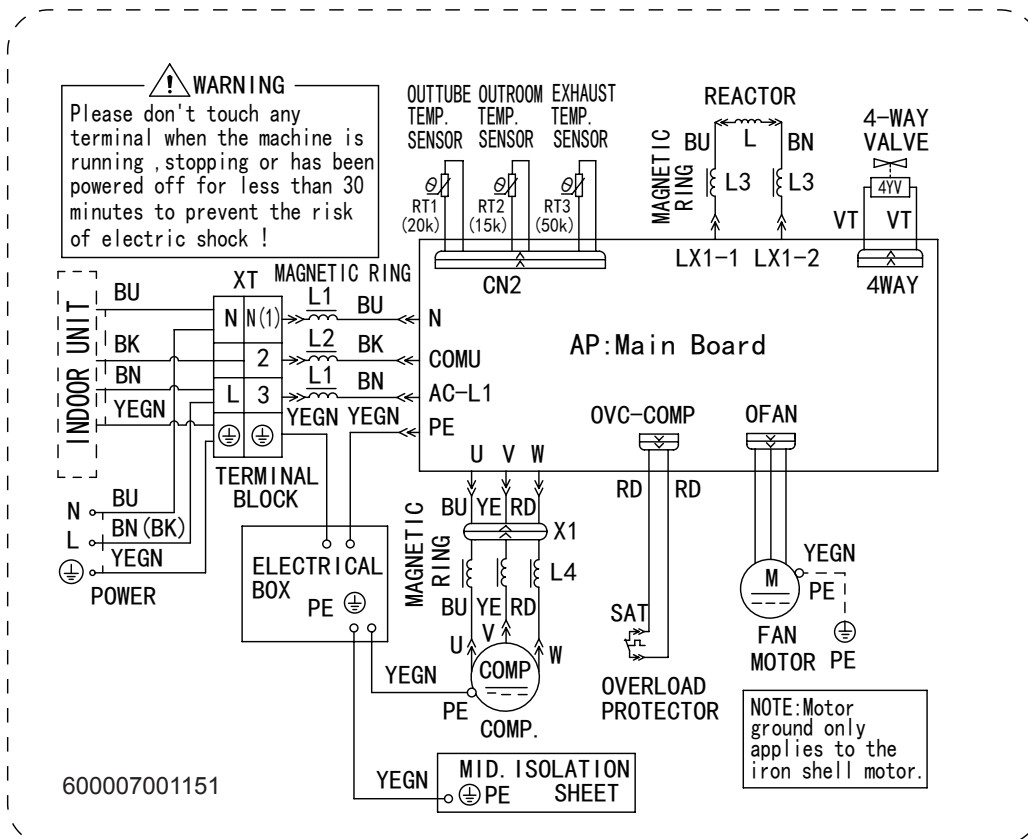

GWH12QB-K6DNB8I/O (CB438W06800)

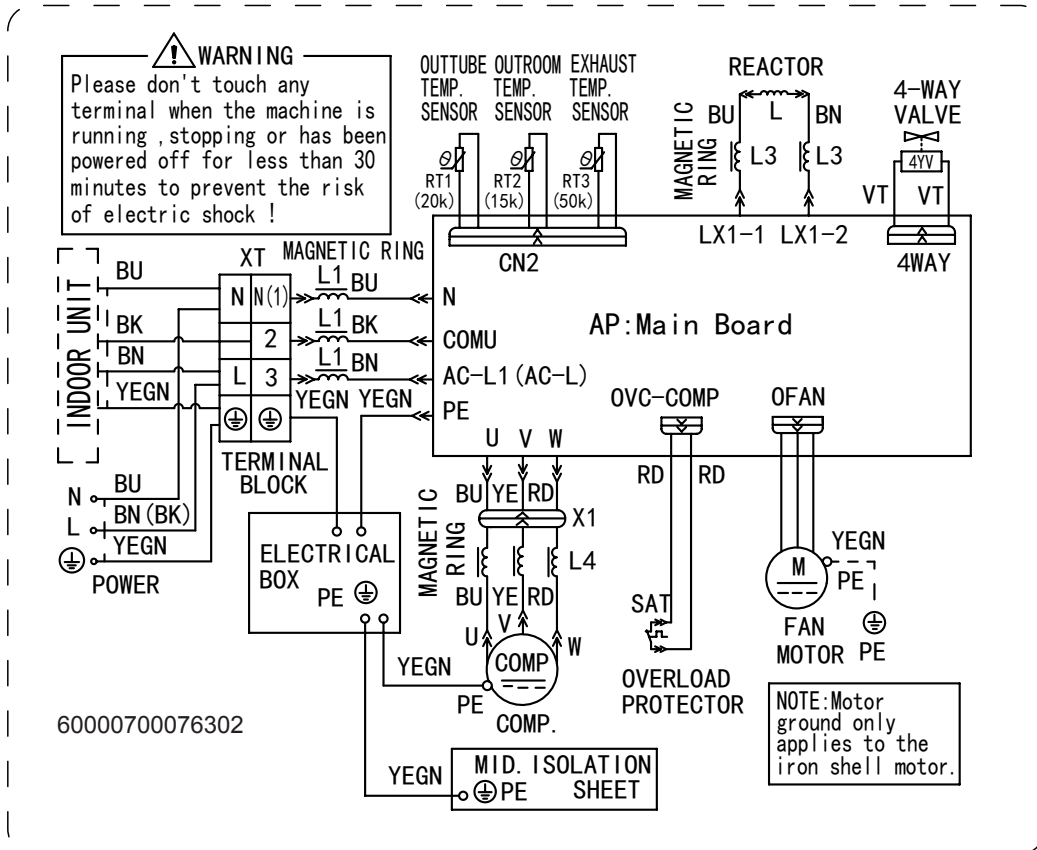

GWH18QD-K6DNA1C/O(CB419W12500)

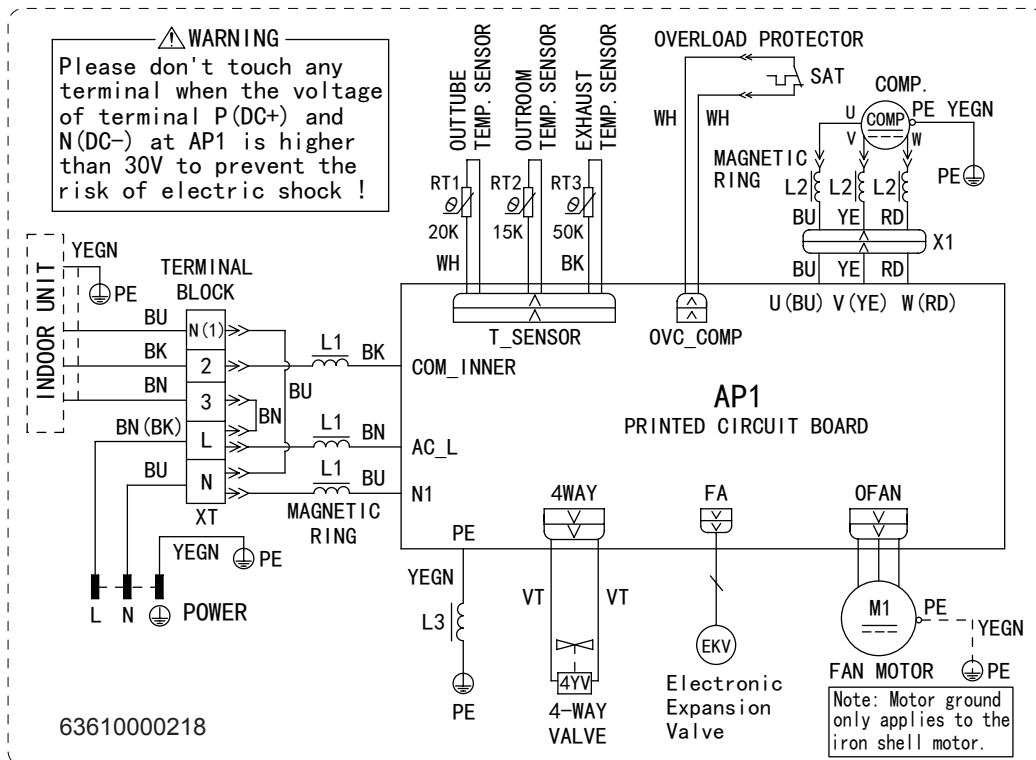

GWH18AAD-K6DNA1B/O

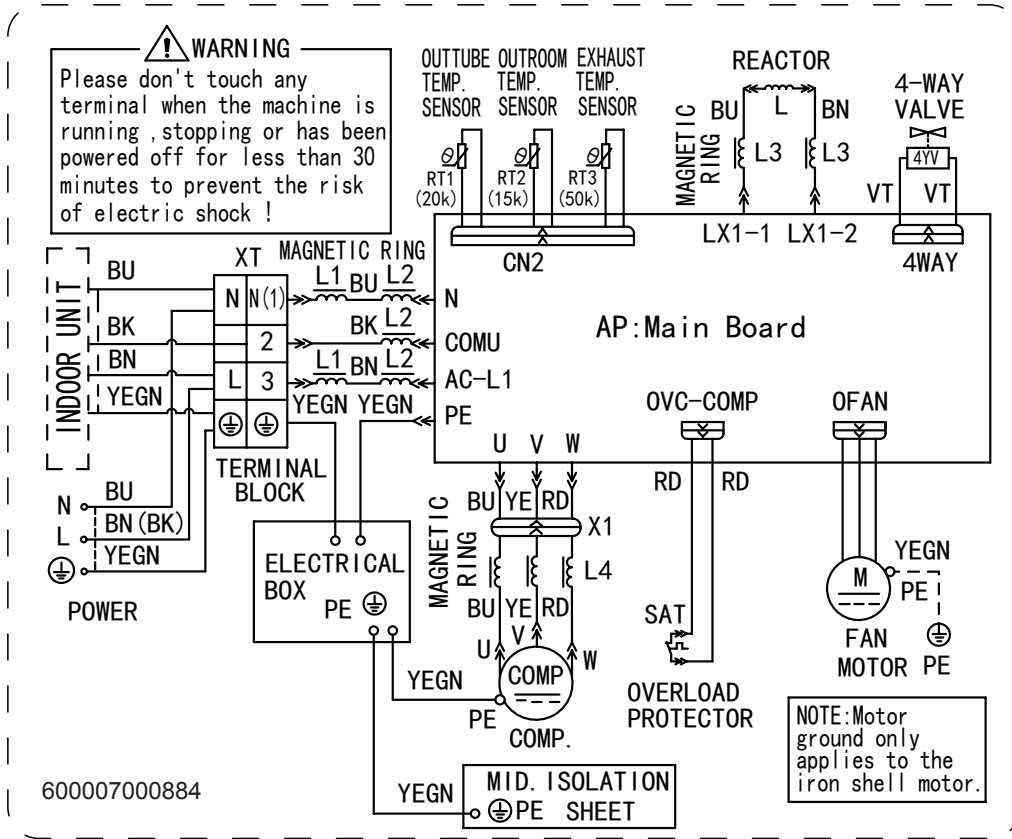

These circuit diagrams are subject to change without notice, please refer to the one supplied with the unit.

5.2 PCB Printed Diagram

Indoor Unit

All models is except:GWH12QB-K6DNC4I/I GWH12QB-K6DNE4I/I GWH09QB-K6DNA1E/I GWH12QB-K6DNC2I/I GWH12QB-K6DNA6I/I

• Top view

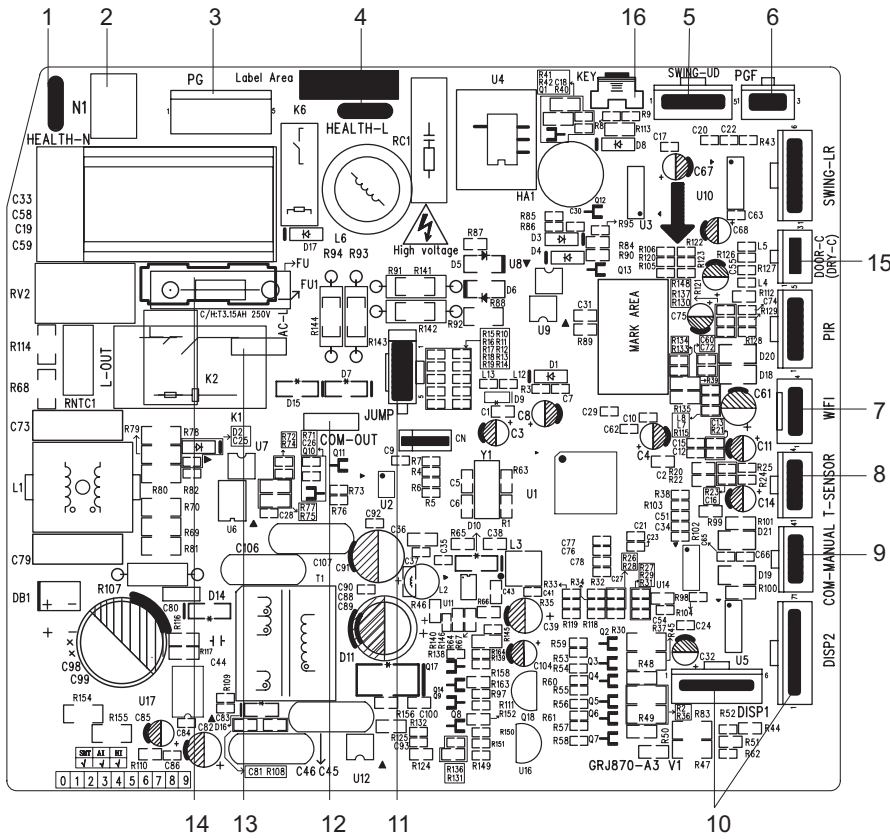

No.	Name
1	Neutral wire interface of cold plasma(only for the mode with this function)
2	Neutral wire interface of power supply
3	Interface of indoor fan
4	Interface of health function live wire
5	Interface of up&down swing motor
6	Interface of PG feedback
7	WIFI
8	Temperature sensor
9	Wired controller
10	Interface of diplay
11	Jumper cap
12	Communication wire
13	Live wire
14	Fuse
15	Interface of gate-control detection
16	Auto mode

• Bottom view

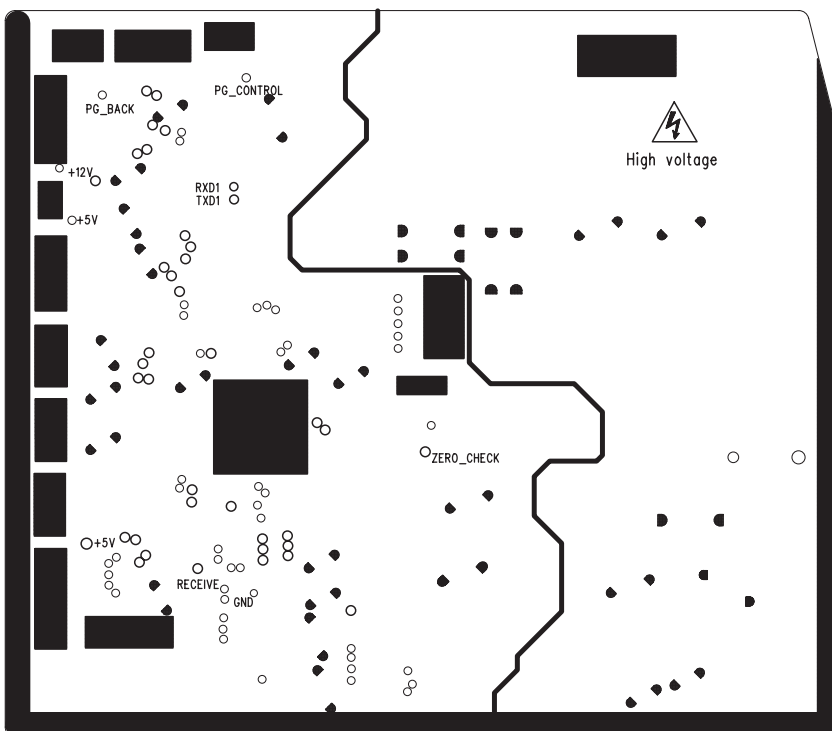

GWH12QB-K6DNC4/I GWH12QB-K6DNE4/I GWH12QB-K6DNC2/I GWH12QB-K6DNA6/I

• Top view

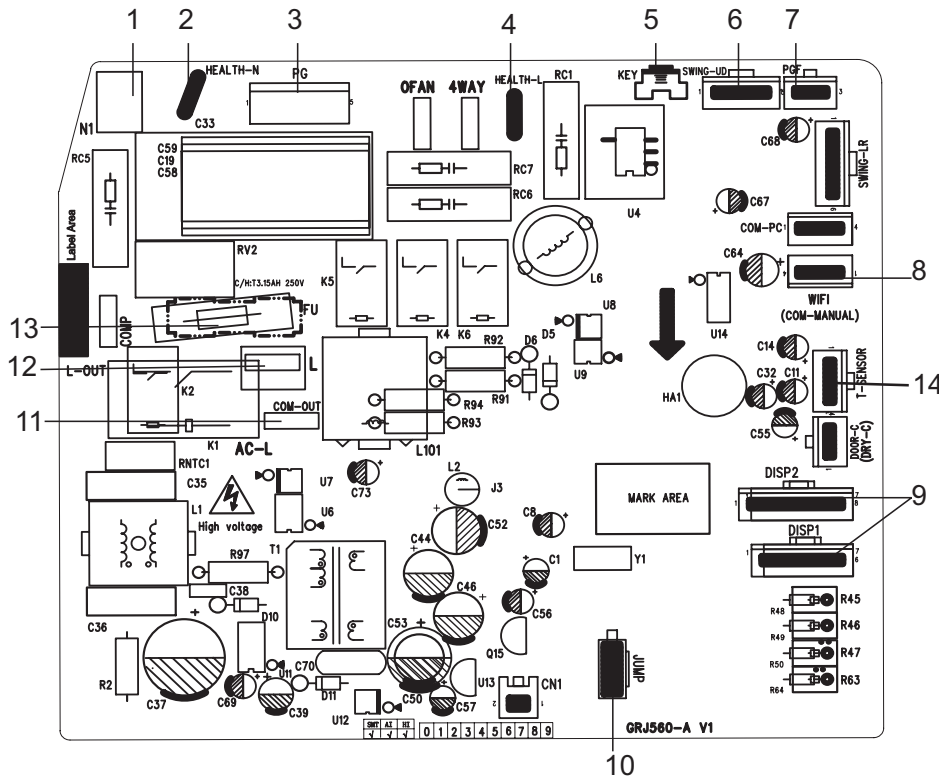

No	Name
1	Neutral wire
2	Neutral wire for health function
3	fan motor
4	Live wire for health
5	Auto button
6	Up and down swing terminal
7	Feedback interface of indoor fan
8	WIFI
9	Display
10	Jumper cap
11	Indoor unit and outdoor unit communication
12	Live wire
13	Fuse
14	Terminal of Temperature Sensor

• Bottom view

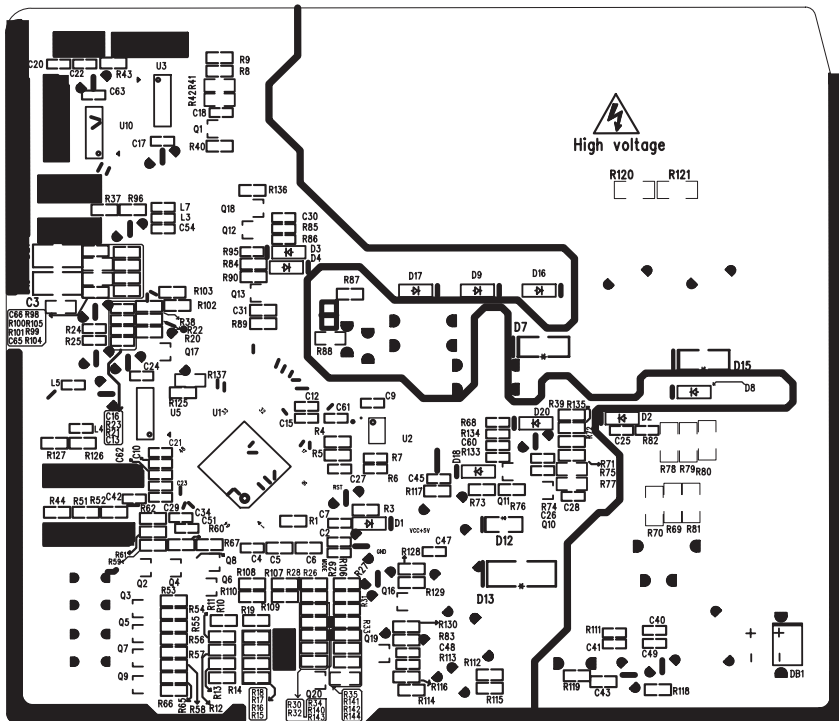

GWH09QB-K6DNA1E/I

● Top view

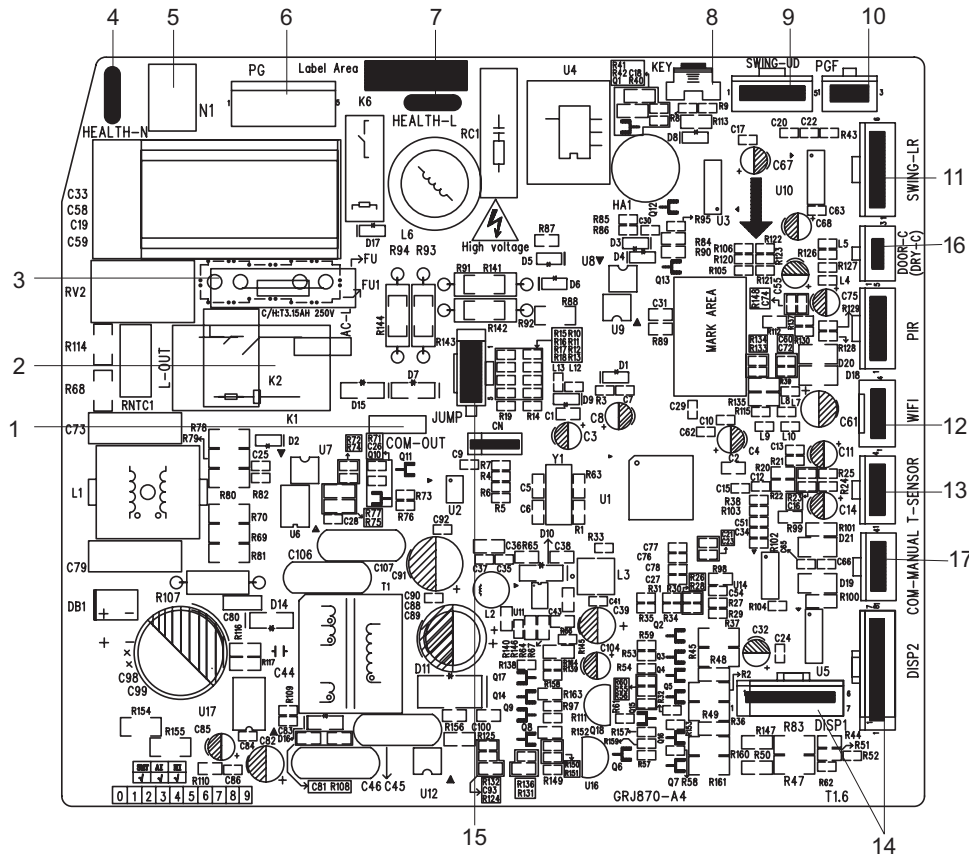

No	Name
1	Interface of communication wire for indoor unit and outdoor unit
2	Interface of live wire
3	Fuse
4	Interface of health function neutral wire
5	Interface of neutral wire
6	Interface of fan
7	Interface of health function live wire
8	Auto button
9	Up&down swing interface
10	Interface of PG feedback
11	Left&right swing interface
12	Interface of wifi
13	Needle stand for tube temperature sensor
14	Display interface
15	Jump
16	Terminal for gate control function
17	Wired controller

● Bottom view

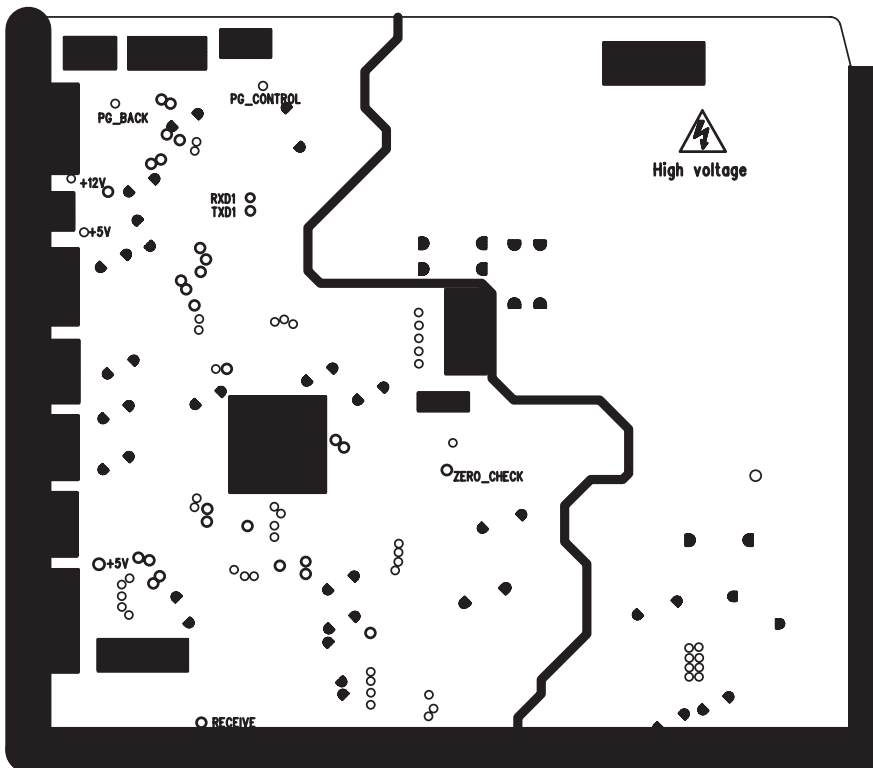

Outdoor Unit

All 09/12K models is except:GWH12QB-K6DNB8I/O

• Top view

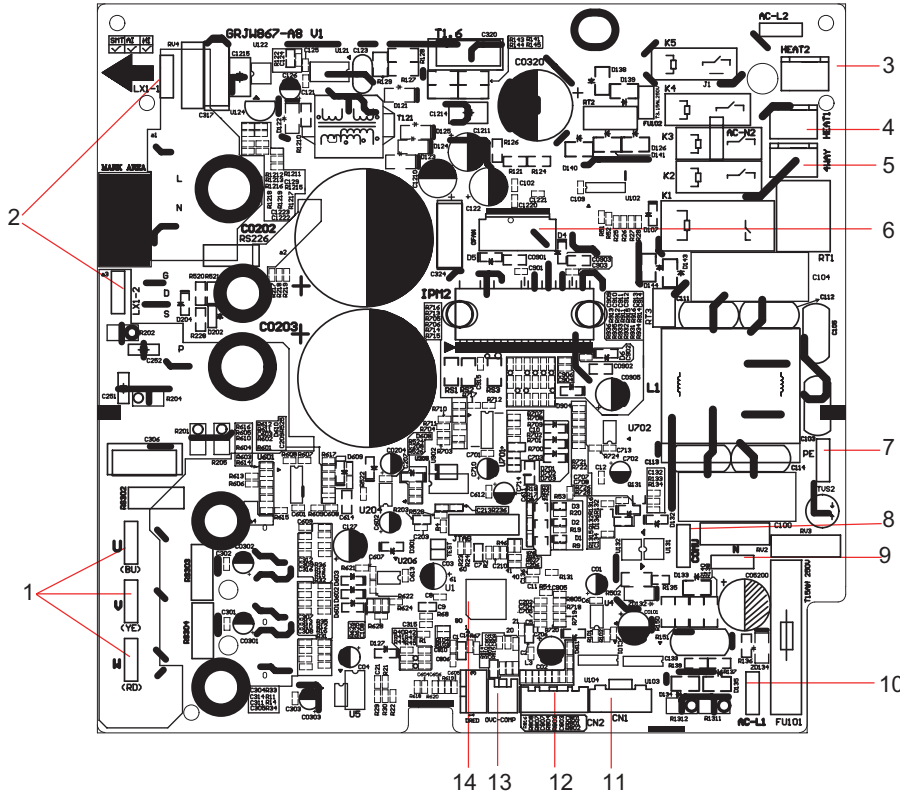

No.	Name
1	Interface of compressor wire
2	Interface of reactor
3	Terminal of chassis electric heater
4	Terminal of compressor electric heater
5	Terminal of 4-way valve
6	Interface of outdoor fan
7	Interface of earthing wire
8	Communication interface
9	Interface of netural wire
10	Interface of live wire
11	Terminal of electronic expansion valve
12	Interface of temperature sensor
13	Overload interface of compressor
14	Main chip

• Bottom view

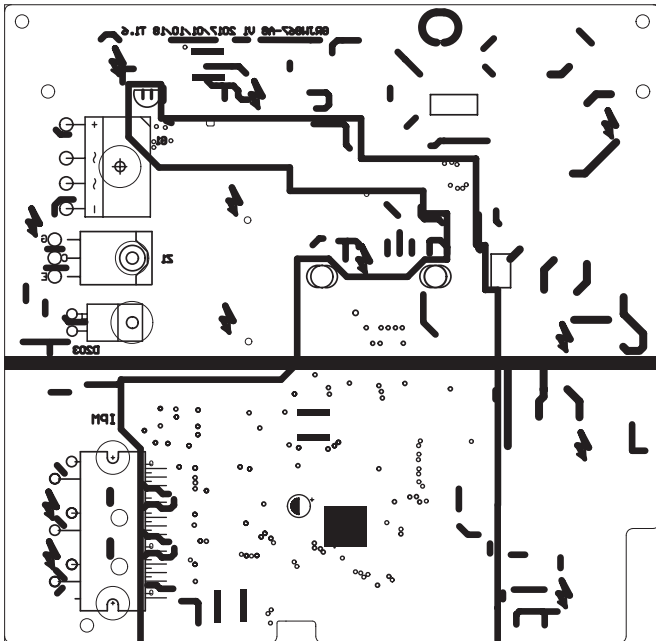

GWH12QB-K6DNB8I/O

● Top view

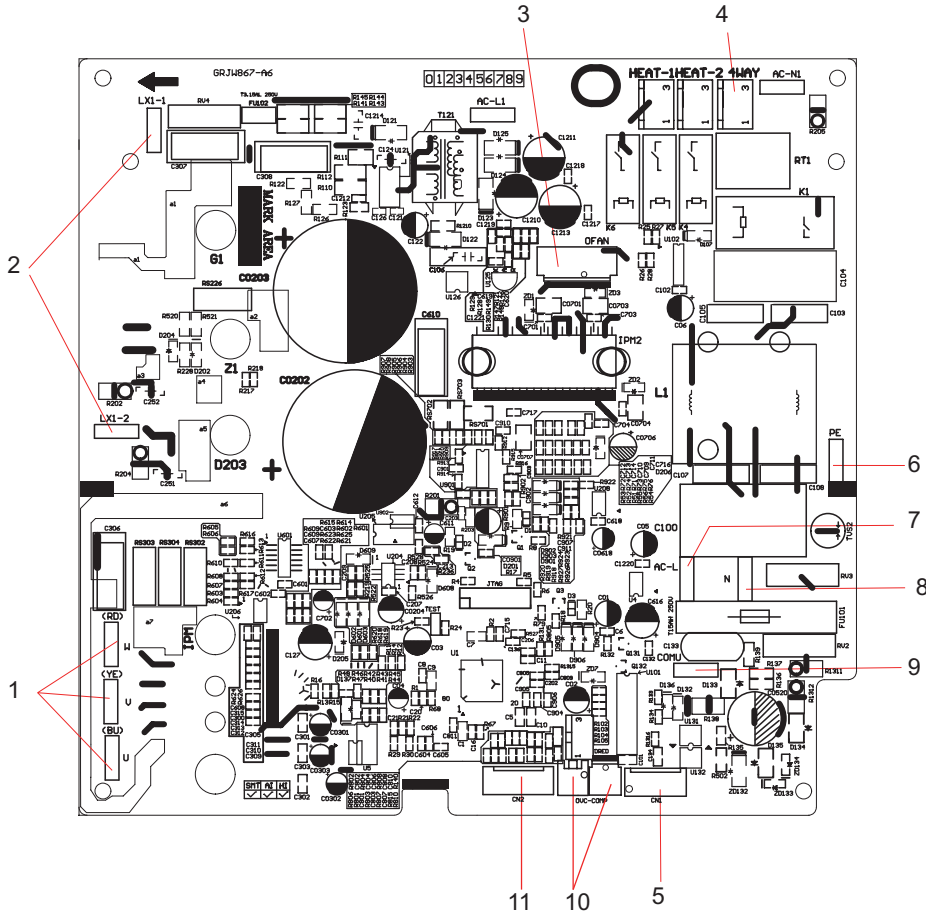

No.	Name
1	Interface of compressor wire
2	Interface of reactor
3	Terminal of outdoor fan
4	Interface of 4-way valve
5	Terminal of electronic expansion valve
6	Grounding wire
7	Live wire
8	Neutral wire
9	Communication wire
10	Overload interface of compressor
11	Interface of temperature sensor

● Bottom view

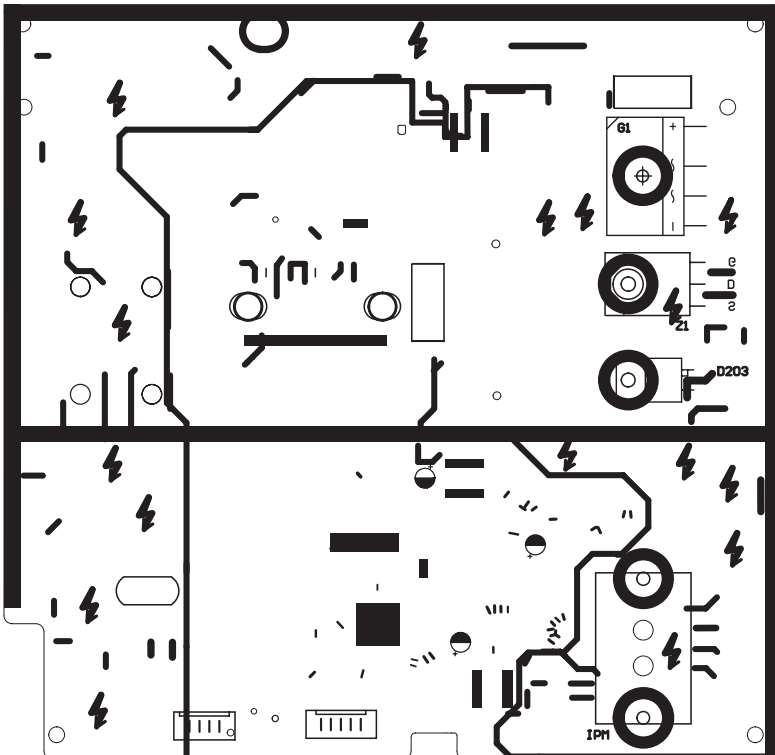

1. ON/OFF button

Press this button to turn on the unit. Press this button again to turn off the unit.

2. MODE button

Press this button to select your required operation mode.

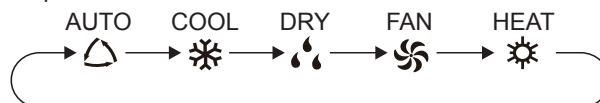

- When selecting auto mode, air conditioner will operate automatically according to ex-factory setting. Set temperature cant be adjusted and will not be displayed as well. Press "FAN" button can adjust fan speed. Press "SWING" button can adjust fan blowing angle.
- After selecting cool mode, air conditioner will operate under cool mode. Cool indicator on indoor unit is ON(This indicator is not available for some models). Press "▲" or "▼" button to adjust set temperature. Press "FAN" button to adjust fan speed. Press "SWING" button to adjust fan blowing angle.
- When selecting dry mode, the air conditioner operates at low speed under dry mode. Dry indicator "💧" on indoor unit is ON(This indicator is not available for some models). Under dry mode, fan speed cant be adjusted. Press "SWING" button to adjust fan blowing angle.
- When selecting fan mode, the air conditioner will only blow fan, no cooling and no heating. All indicators are OFF. Press "FAN" button to adjust fan speed. Press "SWING" button to adjust fan blowing angle.
- When selecting heating mode, the air conditioner operates under heat mode. Heat indicator on indoor unit is ON(This indicator is not available for some models). Press "▲" or "▼" button to adjust set temperature. Press "FAN" button to adjust fan speed. Press "SWING" button to adjust fan blowing angle. (Cooling only unit wont receive heating mode signal. If setting heat mode with remote controller, press ON/OFF button cant start up the unit).

Note:

- For preventing cold air, after starting up heating mode, indoor unit will delay 1~5 minutes to blow air (actual delay time is depend on indoor ambient temperature).
- Set temperature range from remote controller: 16~30℃ ; Fan speed: auto, low speed, medium speed, high speed.

3. FAN button

Pressing this button can set fan speed circularly as: auto (AUTO), low(▲), medium(▲▲), high(▲▲▲).

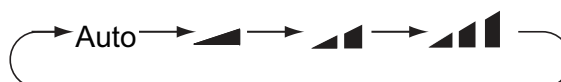

Note:

- Under AUTO speed, air conditioner will select proper fan speed automatically according to ex-factory setting.
- Fan speed under dry mode is low speed.
- X-FAN function: Hold fan speed button for 2s in COOL or DRY mode, the icon "☼" is displayed and the indoor fan will continue operation for a few minutes in order to dry the indoor unit even though you have turned off the unit. After energization, X-FAN OFF is defaulted. X-FAN is not available in AUTO, FAN or HEAT mode.

This function indicates that moisture on evaporator of indoor unit will be blown after the unit is stopped to avoid mould.

- Having set X-FAN function on: After turning off the unit by pressing ON/OFF button indoor fan will continue running for a few minutes. at low speed. In this period, Hold fan speed button for 2s to stop indoor fan directly.
- Having set X-FAN function off: After turning off the unit by pressing ON/OFF button, the complete unit will be off directly.

4. SWING button

Press this button can select up&down swing angle. Fan blow angle can be selected circularly as below:

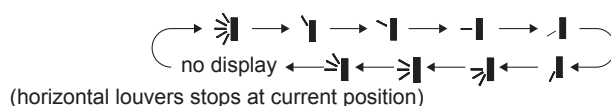

- When selecting "☼", air conditioner is blowing fan automatically. Horizontal louver will automatically swing up & down at maximum angle.
- When selecting "↑", "↓", "←", "→", "↖", "↗", air conditioner is blowing fan at fixed position. Horizontal louver will stop at the fixed position.
- When selecting "↘", "↙", "↗", "↖", air conditioner is blowing fan at fixed angle. Horizontal louver will send air at the fixed angle.

Hold "☼" button above 2s to set your required swing angle. When reaching your required angle, release the button.

Note:

- "↘", "↙", "↗", "↖" may not be available. When air conditioner receives this signal, the air conditioner will blow fan automatically.

5. TURBO button

Under COOL or HEAT mode, press this button to turn to quick COOL or quick HEAT mode. "⚡" icon is displayed on remote controller. Press this button again to exit turbo function and "⚡" icon will disappear.

6. ▲/▼ button

- Press "▲" or "▼" button once increase or decrease set temperature 1°C . Holding "▲" or "▼" button, 2s later, set temperature on remote controller will change quickly. On releasing button after setting is finished, temperature indicator on indoor unit will change accordingly. (Temperature cant be adjusted under auto mode)
- When setting TIMER ON, TIMER OFF or CLOCK, press "▲" or "▲" button to adjust time. (Refer to CLOCK, TIMER ON, TIMER OFF buttons) When setting TIMER ON, TIMER OFF or CLOCK, press "▲" or "▲" button to adjust time. (Refer to CLOCK, TIMER ON, TIMER OFF buttons)

7. SLEEP button

Under COOL, HEAT or DRY mode, press this button to start up sleep function. "☾" icon is displayed on remote controller. Press this button again to cancel sleep function and "☾" icon will disappear.

8. TEMP button

By pressing this button, you can see indoor set temperature, indoor ambient temperature or outdoor ambient temperature on indoor units display. The setting on remote controller is selected circularly as below:

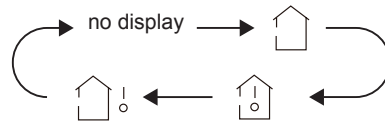

- When selecting "🏠" or no display with remote controller, temperature indicator on indoor unit displays set temperature.
- When selecting "🏠🌡️" with remote controller, temperature indicator on indoor unit displays indoor ambient temperature.
- When selecting "🏠🌡️🌡️" with remote controller, temperature indicator on indoor unit displays outdoor ambient temperature.

Note:

- Outdoor temperature display is not available for some models. At that time, indoor unit receives "🏠🌡️" signal, while it displays indoor set temperature.
- Its defaulted to display set temperature when turning on the unit. There is no display in the remote controller.
- Only for the models whose indoor unit has dual-8 display.
- When selecting displaying of indoor or outdoor ambient temperature, indoor temperature indicator displays corresponding temperature and automatically turn to display set temperature after three or five seconds.

9. WIFI button

Press "WiFi" button to turn on or turn off WiFi function. When WiFi function is turned on, the "WiFi" icon will be displayed on remote controller; Under status of remote controller off, press "MODE" and "WiFi" buttons simultaneously for 1s, WiFi module will restore to factory default setting.

10. LIGHT button

Press this button to turn off display light on indoor unit. "💡" icon on remote controller disappears. Press this button again to turn on display light. "💡" icon is displayed.

11. CLOCK button

Press this button to set clock time. "🕒" icon on remote controller will blink. Press "▲" or "▼" button within 5s to set clock time. Each pressing of "▲" or "▼" button, clock time will increase or decrease 1 minute. If hold "▲" or "▼" button, 2s later, time will change quickly. Release this button when reaching your required time. Press "CLOCK" button to confirm the time. "🕒" icon stops blinking.

Note:

- Clock time adopts 24-hour mode.
- The interval between two operation cant exceeds 5s. Otherwise, remote controller will quit setting status. Operation for TIMER ON/TIMER OFF is the same.

12. TIMER ON / TIMER OFF button

● TIMER ON button

"TIMER ON" button can set the time for timer on. After pressing this button, "🕒" icon disappears and the word "ON" on remote controller blinks. Press "▲" or "▼" button to adjust TIMER ON setting. After each pressing "▲" or "▼" button, TIMER ON setting will increase or decrease 1min. Hold "▲" or "▼" button, 2s later, the time will change quickly until reaching your required time. Press "TIMER ON" to confirm it. The word "ON" will stop blinking. "🕒" icon resumes displaying. Cancel TIMER ON: Under the condition that TIMER ON is started up, press "TIMER ON" button to cancel it.

● TIMER OFF button

"TIMER OFF" button can set the time for timer off. After pressing this button, "🕒" icon disappears and the word "OFF" on remote controller blinks. Press "▲" or "▼" button to adjust TIMER OFF setting. After each pressing "▲" or "▼" button, TIMER OFF setting will increase or decrease 1min. Hold "▲" or "▼" button, 2s later, the time will change quickly until reaching your required time. Press "TIMER OFF" word "OFF" will stop blinking. "🕒" icon resumes displaying. Cancel TIMER OFF. Under the condition that TIMER OFF is started up, press "TIMER OFF" button to cancel it.

Note:

- Under on and off status, you can set TIMER OFF or TIMER ON simultaneously.
- Before setting TIMER ON or TIMER OFF, please adjust the clock time.
- After starting up TIMER ON or TIMER OFF, set the constant circulating valid. After that, air conditioner will be turned on or turned off according to setting time. ON/OFF button has no effect on setting. If you don't need this function, please use remote controller to cancel it.

Health function

Health function will be set during operation of indoor fan.

Turn off the unit will also turn off health function.

This function is only available for some models.

Function introduction for combination buttons**1. Energy-saving function**

Under cooling mode, press "TEMP" and "CLOCK" buttons simultaneously to start up or turn off energy-saving function. When energy-saving function is started up, "SE" will be shown on remote controller, and air conditioner will adjust the set temperature automatically according to ex-factory setting to reach to the best energy-saving effect. Press "TEMP" and "CLOCK" buttons simultaneously again to exit energy-saving function.

Note:

- Under energy-saving function, fan speed is defaulted at auto speed and it can't be adjusted.
- Under energy-saving function, set temperature can't be adjusted. Press "TURBO" button and the remote controller won't send signal.
- Sleep function and energy-saving function can't operate at the same time. If energy-saving function has been set under cooling mode, press sleep button will cancel energy-saving function. If sleep function has been set under cooling mode, start up the energy-saving function will cancel sleep function.

2. 8 °C heating function

Under heating mode, press "TEMP" and "CLOCK" buttons simultaneously to start up or turn off 8 °C heating function. When this function is started up, "8°C" and "8°C" will be shown on remote controller, and the air conditioner keep the heating status at 8 °C. Press "TEMP" and "CLOCK" buttons simultaneously again to exit 8 °C heating function.

Note:

- Under 8 °C heating function, fan speed is defaulted at auto speed and it can't be adjusted.
- Under 8 °C heating function, set temperature can't be adjusted. Press "TURBO" button and the remote controller won't send signal.
- Sleep function and 8 °C heating function can't operate at the same time. If 8 °C heating function has been set under cooling mode, press sleep button will cancel 8 °C heating function. If sleep function has been set under cooling mode, start up the 8 °C heating function will cancel sleep function.
- Under °F temperature display, the remote controller will display 46 °F heating.

3. Child lock function

Press "▲" and "▼" simultaneously to turn on or turn off child lock function. When child lock function is on, "🔒" icon is displayed on remote controller. If you operate the remote controller, the "🔒" icon will blink three times without sending signal to the unit.

4. Temperature display switchover function

Under OFF status, press "▼" and "MODE" buttons simultaneously to switch temperature display between °C and °F.

5. I FEEL Function

Press "▲" and "MODE" buttons simultaneously to start I FEEL function and "I FEEL" will be displayed on the remote controller. After this function is set, the remote controller will send the detected ambient temperature to the controller and the unit will automatically adjust the indoor temperature according to the detected temperature. Press these two buttons simultaneously again to close I FEEL function and "I FEEL" will disappear.

- Please put the remote controller near user when this function is set. Do not put the remote controller near the object of high temperature or low temperature in order to avoid detecting inaccurate ambient temperature. When I FEEL function is turned on, the remote controller should be put within the area where indoor unit can receive the signal sent by the remote controller.

Operation guide

1. After putting through the power, press "ON/OFF" button on remote controller to turn on the air conditioner.
2. Press "MODE" button to select your required mode: AUTO, COOL, DRY, FAN, HEAT.
3. Press "▲" or "▼" button to set your required temperature. (Temperature can't be adjusted under auto mode).
4. Press "FAN" button to set your required fan speed: auto, low, medium and high speed.
5. Press "SWING" button to select fan blowing angle.

Replacement of batteries in remote controller

1. Press the back side of remote controller marked with "  ", as shown in the fig, and then push out the cover of battery box along the arrow direction.
2. Replace two 7# (AAA 1.5V) dry batteries, and make sure the position of "+" polar and "-" polar are correct.
3. Reinstall the cover of battery box.

Note:

- During operation, point the remote control signal sender at the receiving window on indoor unit.
- The distance between signal sender and receiving window should be no more than 8m, and there should be no obstacles between them.
- Signal may be interfered easily in the room where there is fluorescent lamp or wireless telephone; remote controller should be close to indoor unit during operation.
- Replace new batteries of the same model when replacement is required.
- When you dont use remote controller for a long time, please take out the batteries.
- If the display on remote controller is fuzzy or theres no display, please replace batteries.

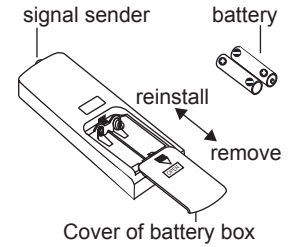

6.2 GREE+ App Operation Manual

Control Flow Chart

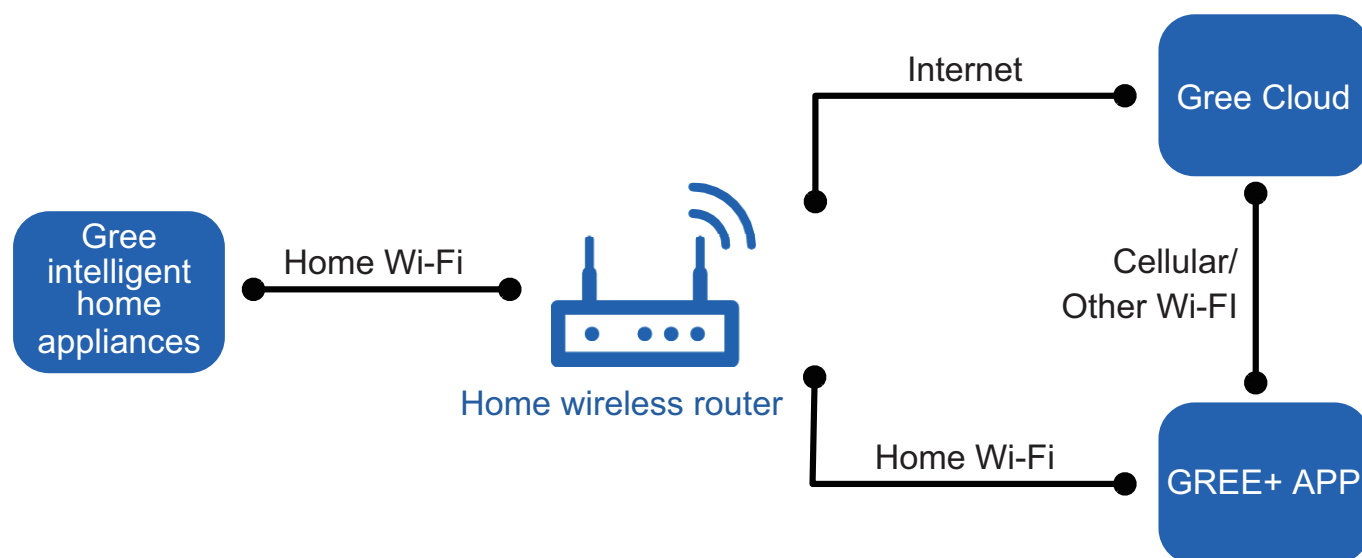

Operating Systems

Requirement for User's smart phone:



iOS system
Support iOS7.0 and
above version



Android system
Support Android 4.4 and
above version

Download and installation



GREE+ App Download Linkage

Scan the QR code or search "GREE+" in the application market to download and install it. When "GREE+" App is installed, register the account and add the device to achieve long-distance control and LAN control of Gree smart home appliances.

For more information, please refer to "Help" in App.

6.3 Ewpe Smart App Operation Manual

Control Flow Chart

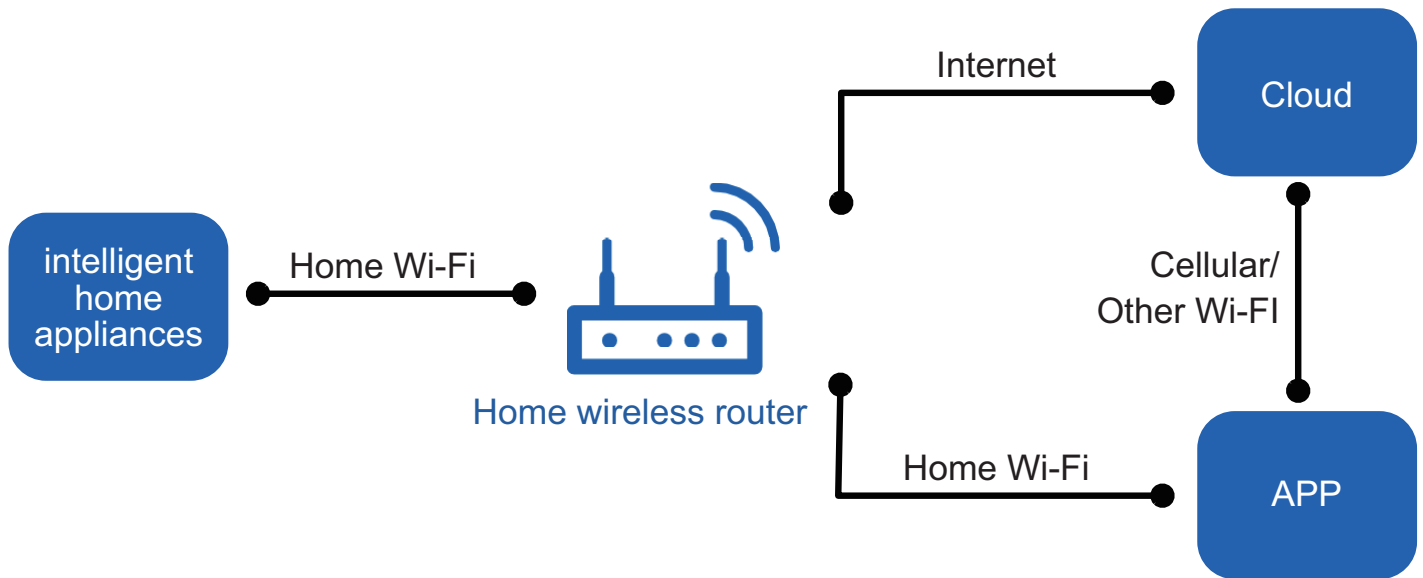

Operating Systems

Requirement for User's smart phone:



iOS system
Support iOS7.0 and above version



Android system
Support Android 4.4 and above version

Download and installation



App Download Linkage

Scan the QR code or search "Ewpe Smart" in the application market to download and install it. When "Ewpe Smart" App is installed, register the account and add the device to achieve long-distance control and LAN control of smart home appliances. For more information, please refer to "Help" in App.

6.4 Brief Description of Modes and Functions

● Indoor Unit

1. Basic function of system

(1) Cooling mode

- (1) Under this mode, fan and swing operates at setting status. Temperature setting range is 16~30°C.
- (2) During malfunction of outdoor unit or the unit is stopped because of protection, indoor unit keeps original operation status.

(2) Drying mode

- (1) Under this mode, fan operates at low speed and swing operates at setting status. Temperature setting range is 16~30°C.
- (2) During malfunction of outdoor unit or the unit is stopped because of protection, indoor unit keeps original operation status.
- (3) Protection status is same as that under cooling mode.
- (4) Sleep function is not available for drying mode.

(3) Heating mode

- (1) Under this mode, Temperature setting range is 16~30°C.
- (2) Working condition and process for heating mode:
When turn on the unit under heating mode, indoor unit enters into cold air prevention status. When the unit is stopped or at OFF status, and indoor unit has been started up just now, the unit enters into residual heat-blowing status.

(4) Working method for AUTO mode:

1. Working condition and process for AUTO mode:
 - a. Under auto mode set temperature can be adjusted. The unit switch mode automatically according to ambient temperature.
2. Protection function
 - a. During cooling operation, protection function is same as that under cooling mode.
 - b. During heating operation, protection function is same as that under heating mode.
3. Display: Set temperature is the set value under each condition. Ambient temperature is (Tamb.-Tcompensation) for heat pump unit and Tamb. for cooling only unit.
4. If theres I feel function, Tcompensation is 0. Others are same as above.

(5) Fan mode

Under this mode, indoor fan operates at set fan speed. Compressor, outdoor fan, 4-way valve and electric heating tube stop operation. Indoor fan can select to operate at high, medium, low or auto fan speed. Temperature setting range is 16~30°C.

2. Other control

(1) Buzzer

Upon energization or availably operating the unit or remote controller, the buzzer will give out a beep.

(2) Auto button

If press this auto button when turning off the unit, the complete unit will operate at auto mode. Indoor fan operates at auto fan speed and swing function is turned on. Press this auto button at ON status to turn off the unit.

(3) Auto fan

Heating mode: During auto heating mode or normal heating ode, auto fan speed will adjust the fan speed automatically according to ambient temperature and set temperature.

(4) Sleep

After setting sleep function for a period of time, system will adjust set temperature automatically.

(5) Timer function:

General timer and clock timer functions are compatible by equipping remote controller with different functions.

(6) Memory function

memorize compensation temperature, off-peak energization value.

Memory content: mode, up&down swing, light, set temperature, set fan speed, general timer (clock timer cant be memorized).

After power recovery, the unit will be turned on automatically according to memory content.

(7) Health function

During operation of indoor fan, set health function by remote controller. Turn off the unit will also turn off health function.

Turn on the unit by pressing auto button, and the health is defaulted ON.

(8)I feel control mode

After controller received I feel control signal and ambient temperature sent by remote controller, controller will work according to the ambient temperature sent by remote controller.

(9)Entry condition for compulsory defrosting function

When turn on the unit under heating mode and set temperature is 16°C (or 16.5°C by remote controller), press “+, -, +, -, +, -” button successively within 5s and then indoor unit will enter into compulsory defrosting setting status:

(1) If there's only indoor units controller, it enters into indoor normal defrosting mode.

(2) If there's indoor units controller and outdoor units controller, indoor unit will send compulsory defrosting mode signal to outdoor unit and then outdoor unit will operate under normal defrosting mode. After indoor unit received the signal that outdoor unit has entered into defrosting status, indoor unit will cancel to send compulsory mode to outdoor unit. If outdoor unit hasn't received feedback signal from outdoor unit after 3min, indoor unit will also cancel to send compulsory defrosting signal.

(10)Refrigerant recovery function:

Enter into Freon recovery mode actively: Within 5min after energization, turn on the unit at 16°C under cooling mode, and press light button for 3 times within 3s to enter into Freon recovery mode. Fo is displayed and Freon recovery mode will be sent to outdoor unit.

(11)Ambient temperature display control mode

1. When user set the remote controller to display set temperature (corresponding remote control code: 01), current set temperature will be displayed.

2. Only when remote control signal is switched to indoor ambient temperature display status (corresponding remote control code: 10) from other display status (corresponding remote control code: 00, 01,11),controller will display indoor ambient temperature for 3s and then turn back to display set temperature.

Under this mode, indoor fan operates at set fan speed. Compressor, outdoor fan, 4-way valve and electric heating tube stop operation. Indoor fan can select to operate at high, medium, low or auto fan speed. Temperature setting range is 16~30°C.

(12)Off-peak energization function:

Adjust compressors minimum stop time. The original minimum stop time is 180s and then we change to:

The time interval between two start-ups of compressor can't be less than $180+T_s(0\leq T\leq 15)$. T is the variable of controller. That's to say the minimum stop time of compressor is 180s~195s. Read-in T into memory chip when refurbish the memory chip each time. After power recovery, compressor can only be started up after $180+T$ s at least.

(13) SE control mode

The unit operates at SE status.

(14) X-fan mode

When X-fan function is turned on, after turn off the unit, indoor fan will still operate at low speed for 2min and then the complete unit will be turned off. When x-fan function is turned off, after turn off the unit, the complete unit will be turned off directly.

(15) 8°C heating function

Under heating mode, you can set 8°C heating function by remote controller. The system will operate at 8°C set temperature.

(16)Turbo function

Turbo function can be set under cooling and heating modes. Press Fan Speed button to cancel turbo setting. Turbo function is not available under auto, drying and fan modes.

● Outdoor Unit

1. Cooling mode:

Working condition and process of cooling mode:

- ① When Tindoor ambient temperature $\geq T_{\text{preset}}$, unit enters into cooling mode. Indoor fan, outdoor fan and compressor start operation. Indoor fan operates according to set fan speed.
- ② When Tindoor ambient temperature $\leq T_{\text{preset}} - 2^{\circ}\text{C}$, compressor stops operation and outdoor fan will stop 30s later. Indoor fan operates according to set fan speed.
- ③ When $T_{\text{preset}} - 2^{\circ}\text{C} < \text{Tindoor ambient temperature} < T_{\text{preset}}$, unit operates according to the previous status.

Under cooling mode, 4-way valve is not energized. Temperature setting range is 16~30°C. If compressor stops because of malfunction in cooling mode, indoor fan and swing motor will work according to the original status.

2. Drying mode

(1) Working condition and process of drying mode

- ① When Tindoor ambient temperature $> T_{\text{preset}}$, unit will be in drying mode. Outdoor fan and compressor start operation while indoor fan will operate at low fan speed.
- ② When $T_{\text{preset}} - 2^{\circ}\text{C} \leq \text{Tindoor ambient temperature} \leq T_{\text{preset}}$, unit operates according to the previous status.
- ③ When Tindoor ambient temperature $< T_{\text{preset}} - 2^{\circ}\text{C}$, compressor stops operation and outdoor fan will stop 30s later.

(2) Under drying mode, 4-way valve is not energized. Temperature setting range is 16~30°C.

(3) Protection function: same as in cooling mode.

3. Fan mode

(1) Under this mode, indoor fan can select different fan speed (except Turbo) or auto fan speed. Compressor, outdoor fan and 4-way valve all stop operation.

(2) In fan mode, temperature setting range is 16~30°C.

4. Heating mode

Working condition and process of heating mode:

- ① When $T_{\text{preset}} - (\text{Tindoor ambient temperature} - T_{\text{compensation}}) \geq 1^{\circ}\text{C}$, unit enters into heating mode. Compressor, outdoor fan and 4-way valve start operation.
- ② When $-2^{\circ}\text{C} < T_{\text{preset}} - (\text{Tindoor ambient temperature} - T_{\text{compensation}}) < 1^{\circ}\text{C}$, unit operates according to the previous status.
- ③ When $T_{\text{preset}} - (\text{Tindoor ambient temperature} - T_{\text{compensation}}) \leq -2^{\circ}\text{C}$, compressor stops operation and outdoor fan will stop 30s later. Indoor fan will be in residual-heat blowing status.
- ④ When unit is turned off under heating mode or changed to other modes from heating mode, 4-way valve will be power-off 2min after compressor stops working (compressor is in operation status under heating mode).
- ⑤ When Tindoor ambient temperature $> 30^{\circ}\text{C}$, compressor stops operation immediately. Outdoor fan will stop 30s later.
- ⑥ Under the condition that compressor is turned on, when unit is changed to heating mode from cooling or drying mode, 4-way valve will be energized in 2~3mins delay.

Note: Tcompensation is determined by IDU and ODU. If IDU controls the compensation temperature, then Tcompensation is determined according to the value sent by IDU to ODU; If IDU does not control the compensation temperature, then Tcompensation will default to 3°C by the ODU.

5. Freon recovery mode

After the Freon recovery signal from IDU is received, cooling at rated frequency will be forcibly turned on to recover Freon.

Indoor unit will display Fo. If any signal from remote controller is received, unit will exit from Freon recovery mode and indoor unit stops displaying Fo.

6. Compulsory defrosting

If unit is turned on under heating mode and set temperature is 16°C (by remote controller), press "+, -, +, -, +, -" within 5s, unit will enter into compulsory defrosting mode and send the signal to ODU. When the compulsory defrosting signal from ODU is received, IDU will exit from the compulsory defrosting mode and stop sending the signal to ODU.

After ODU receives the compulsory defrosting code, it will start compulsory defrosting. Defrosting frequency and opening angle will be the same as in normal defrosting mode. When compulsory defrosting is finished, the complete unit resumes original status.

7. Auto mode

Auto mode is determined by controller of IDU. See IDU logic for details.

8. 8°C heating

Set temperature is 8°C. Display board of IDU displays 8°C. Under this mode, “Cold air prevention” function is shielded.

If compressor is operating under this mode, fan speed will adjust according to auto fan speed; if compressor stops operation under this mode, indoor fan will be in residual-heat blowing status.

When power on, communication light will be blinking in a normal way (after receiving a group of correct signals, blinking stops for 0.2s~0.3s). If there's no communication, communication light will be always on. If other ODU has malfunction, communication light will be on for 1s and off for 1s in a circular way.

Part II : Installation and Maintenance

7. Notes for Installation and Maintenance

Safety Precautions: Important!

Please read the safety precautions carefully before installation and maintenance.

The following contents are very important for installation and maintenance.

Please follow the instructions below.

- The installation or maintenance must accord with the instructions.
- Comply with all national electrical codes and local electrical codes.
- Pay attention to the warnings and cautions in this manual.
- All installation and maintenance shall be performed by distributor or qualified person.
- All electric work must be performed by a licensed technician according to local regulations and the instructions given in this manual.
- Be caution during installation and maintenance. Prohibit incorrect operation to prevent electric shock, casualty and other accidents.



Warnings

Electrical Safety Precautions:

1. Cut off the power supply of air conditioner before checking and maintenance.
2. The air condition must apply specialized circuit and prohibit share the same circuit with other appliances.
3. The air conditioner should be installed in suitable location and ensure the power plug is touchable.
4. Make sure each wiring terminal is connected firmly during installation and maintenance.
5. Have the unit adequately grounded. The grounding wire cant be used for other purposes.
6. Must apply protective accessories such as protective boards, cable-cross loop and wire clip.
7. The live wire, neutral wire and grounding wire of power supply must be corresponding to the live wire, neutral wire and grounding wire of the air conditioner.
8. The power cord and power connection wires cant be pressed by hard objects.
9. If power cord or connection wire is broken, it must be replaced by a qualified person.

10. If the power cord or connection wire is not long enough, please get the specialized power cord or connection wire from the manufacture or distributor. Prohibit prolong the wire by yourself.

11. For the air conditioner without plug, an air switch must be installed in the circuit. The air switch should be all-pole parting and the contact parting distance should be more than 3mm.

12. Make sure all wires and pipes are connected properly and the valves are opened before energizing.

13. Check if there is electric leakage on the unit body. If yes, please eliminate the electric leakage.

14. Replace the fuse with a new one of the same specification if it is burnt down; dont replace it with a cooper wire or conducting wire.

15. If the unit is to be installed in a humid place, the circuit breaker must be installed.

Installation Safety Precautions:

1. Select the installation location according to the requirement of this manual.(See the requirements in installation part)
2. Handle unit transportation with care; the unit should not be carried by only one person if it is more than 20kg.
3. When installing the indoor unit and outdoor unit, a sufficient fixing bolt must be installed; make sure the installation support is firm.
4. Ware safety belt if the height of working is above 2m.
5. Use equipped components or appointed components during installation.
6. Make sure no foreign objects are left in the unit after finishing installation.

Improper installation may lead to fire hazard, explosion, electric shock or injury.

Safety Precautions for Installing and Relocating the Unit:

To ensure safety, please be mindful of the following precautions.



Warnings

1. When installing or relocating the unit, be sure to keep the refrigerant circuit free from air or substances other than the specified refrigerant.

Any presence of air or other foreign substance in the refrigerant circuit will cause system pressure rise or compressor rupture, resulting in injury.

2. When installing or moving this unit, do not charge the refrigerant which is not comply with that on the nameplate or unqualified refrigerant.

Otherwise, it may cause abnormal operation, wrong action, mechanical malfunction or even series safety accident.

3. When refrigerant needs to be recovered during relocating or repairing the unit, be sure that the unit is running in cooling mode. Then, fully close the valve at high pressure side (liquid valve). About 30-40 seconds later, fully close the valve at low pressure side (gas valve), immediately stop the unit and disconnect power. Please note that the time for refrigerant recovery should not exceed 1 minute.

If refrigerant recovery takes too much time, air may be sucked in and cause pressure rise or compressor rupture, resulting in injury.

4. During refrigerant recovery, make sure that liquid valve and gas valve are fully closed and power is disconnected before detaching the connection pipe.

If compressor starts running when stop valve is open and connection pipe is not yet connected, air will be sucked in and cause pressure rise or compressor rupture, resulting in injury.

5. When installing the unit, make sure that connection pipe is securely connected before the compressor starts running.

If compressor starts running when stop valve is open and connection pipe is not yet connected, air will be sucked in and cause pressure rise or compressor rupture, resulting in injury.

6. Prohibit installing the unit at the place where there may be leaked corrosive gas or flammable gas.

If there leaked gas around the unit, it may cause explosion and other accidents.

7. Do not use extension cords for electrical connections. If the electric wire is not long enough, please contact a local service center authorized and ask for a proper electric wire.

Poor connections may lead to electric shock or fire.

8. Use the specified types of wires for electrical connections between the indoor and outdoor units. Firmly clamp the wires so that their terminals receive no external stresses.

Electric wires with insufficient capacity, wrong wire connections and insecure wire terminals may cause electric shock or fire.

Safety Precautions for Refrigerant

● To realize the function of the air conditioner unit, a special refrigerant circulates in the system. The used refrigerant is the fluoride R32, which is specially cleaned. The refrigerant is flammable and inodorous. Furthermore, it can lead to explosion under certain conditions. But the flammability of the refrigerant is very low. It can be ignited only by fire.

● Compared to common refrigerants, R32 is a nonpolluting refrigerant with no harm to the ozoneosphere. The influence upon the greenhouse effect is also lower. R32 has got very good thermodynamic features which lead to a really high energy efficiency. The units therefore need a less filling.

WARNING:

● Do not use means to accelerate the defrosting process or to clean, other than those recommended by the manufacture.

Should repair be necessary, contact your nearest authorized Service Centre. Any repairs carried out by unqualified personnel may be dangerous. The appliance shall be stored in a room without continuously operating ignition sources. (for example: open flames, an operating gas appliance or an operating electric heater.)

● Do not pierce or burn.

● Appliance shall be installed, operated and stored in a room with a floor area larger than "X" m² (see table a). (only applies to appliances that are not fixed appliances).

● Appliance filled with flammable gas R32. For repairs, strictly follow manufacturers instructions only. Be aware that refrigerants not contain odour.

● Read specialists manual.

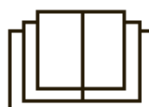

Safety Operation of Flammable Refrigerant

Qualification requirement for installation and maintenance man

- All the work men who are engaging in the refrigeration system should bear the valid certification awarded by the authoritative organization and the qualification for dealing with the refrigeration system recognized by this industry. If it needs other technician to maintain and repair the appliance, they should be supervised by the person who bears the qualification for using the flammable refrigerant.
- It can only be repaired by the method suggested by the equipments manufacturer.

Installation notes

- The air conditioner is not allowed to use in a room that has running fire (such as fire source, working coal gas ware, operating heater).
- It is not allowed to drill hole or burn the connection pipe.
- The air conditioner must be installed in a room that is larger than the minimum room area. The minimum room area is shown on the nameplate or following table a.
- Leak test is a must after installation.

table a - Minimum room area(m²)

Minimum room area(m ²)	Charge amount (kg)	≤1.2	1.3	1.4	1.5	1.6	1.7	1.8	1.9	2	2.1	2.2	2.3	2.4	2.5
	floor location	4	14.5	16.8	19.3	22	24.8	27.8	31	34.3	37.8	41.5	45.4	49.4	53.6
window mounted	4	5.2	6.1	7	7.9	8.9	10	11.2	12.4	13.6	15	16.3	17.8	19.3	
wall mounted	4	4	4	4	4	4	4	4	4	4	4.2	4.6	5	5.5	6
ceiling mounted	4	4	4	4	4	4	4	4	4	4	4	4	4	4	4

Maintenance notes

- Check whether the maintenance area or the room area meet the requirement of the nameplate.
 - Its only allowed to be operated in the rooms that meet the requirement of the nameplate.
- Check whether the maintenance area is well-ventilated.
 - The continuous ventilation status should be kept during the operation process.
- Check whether there is fire source or potential fire source in the maintenance area.
 - The naked flame is prohibited in the maintenance area; and the “no smoking” warning board should be hanged.
- Check whether the appliance mark is in good condition.
 - Replace the vague or damaged warning mark.

Welding

- If you should cut or weld the refrigerant system pipes in the process of maintaining, please follow the steps as below:
 - a. Shut down the unit and cut power supply
 - b. Eliminate the refrigerant
 - c. Vacuuming
 - d. Clean it with N2 gas
 - e. Cutting or welding
 - f. Carry back to the service spot for welding
- Make sure that there isnt any naked flame near the outlet of the vacuum pump and its well-ventilated.
- The refrigerant should be recycled into the specialized storage tank.

Filling the refrigerant

- Use the refrigerant filling appliances specialized for R32. Make sure that different kinds of refrigerant wont contaminate with each other.
- The refrigerant tank should be kept upright at the time of filling refrigerant.
- Stick the label on the system after filling is finished (or havent finished).
- Dont overfilling.
- After filling is finished, please do the leakage detection before test running; another time of leak detection should be done when its removed.

Safety instructions for transportation and storage

- Please use the flammable gas detector to check before unload and open the container.
- No fire source and smoking.
- According to the local rules and laws.

Main Tools for Installation and Maintenance

<p>1. Level meter, measuring tape</p> 	<p>2. Screw driver</p> 	<p>3. Impact drill, drill head, electric drill</p> 
<p>4. Electroprobe</p> 	<p>5. Universal meter</p> 	<p>6. Torque wrench, open-end wrench, inner hexagon spanner</p> 
<p>7. Electronic leakage detector</p> 	<p>8. Vacuum pump</p> 	<p>9. Pressure meter</p> 
<p>10. Pipe pliers, pipe cutter</p> 	<p>11. Pipe expander, pipe bender</p> 	<p>12. Soldering appliance, refrigerant container</p> 

8. Installation

8.1 Installation Dimension Diagram

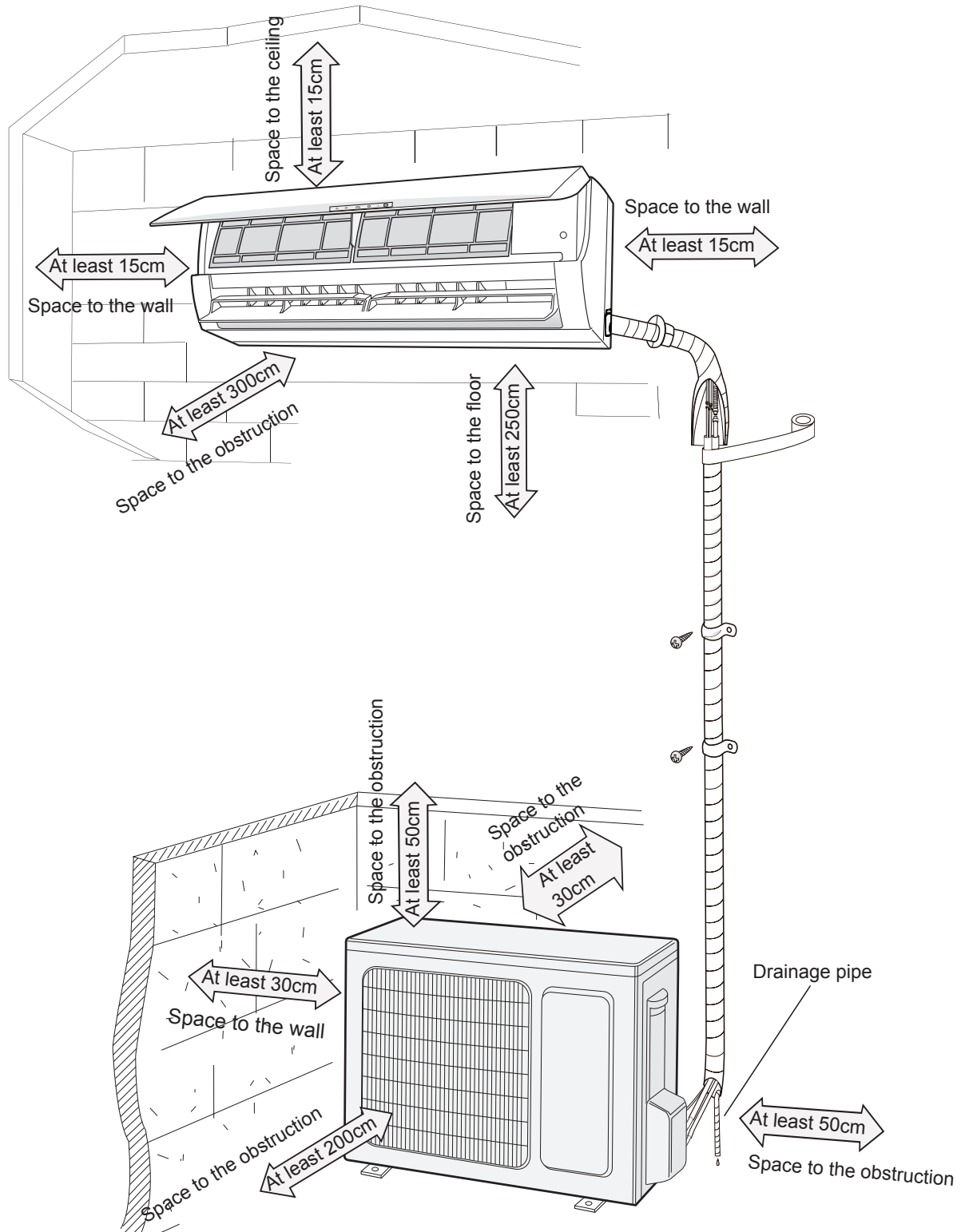

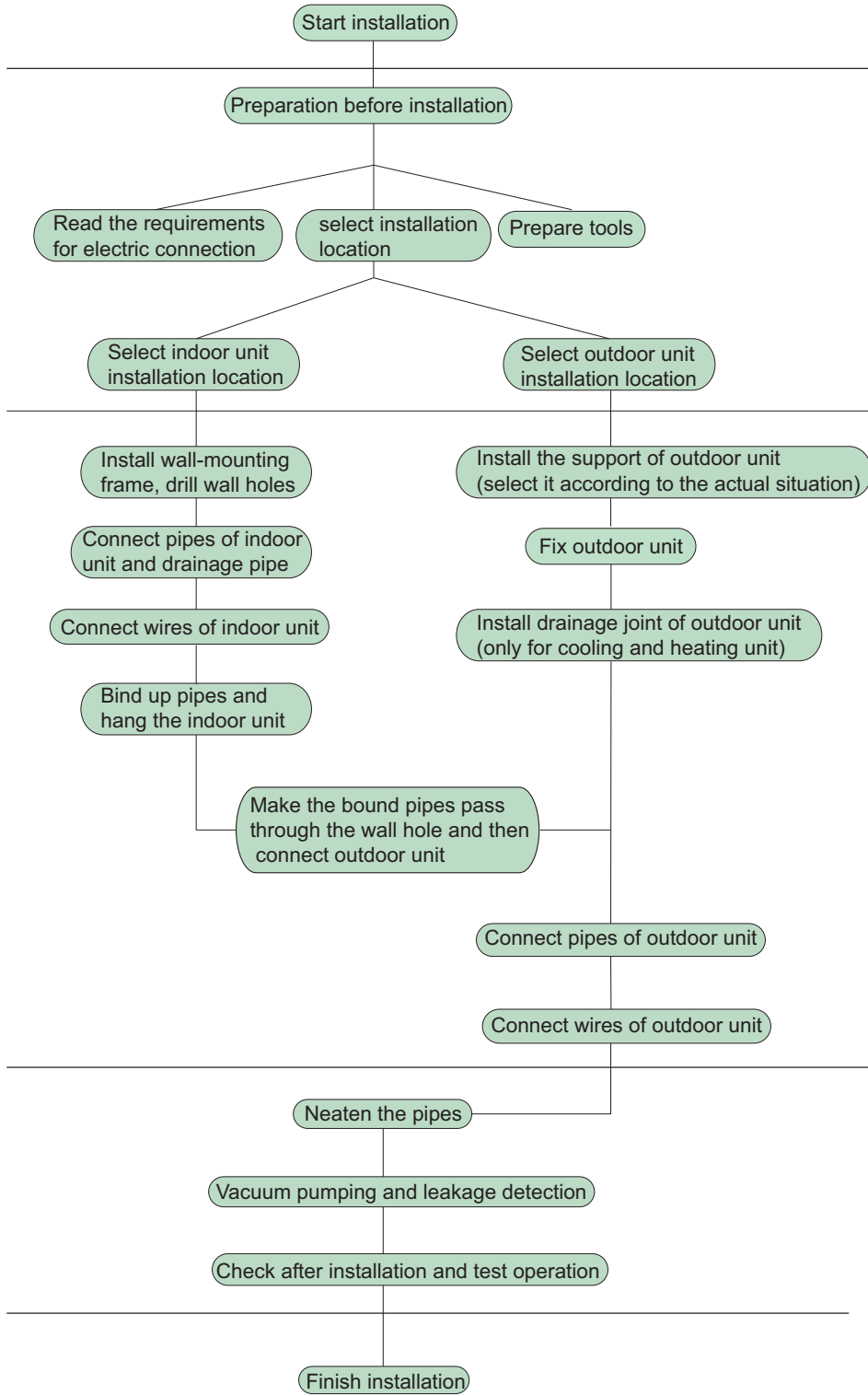

Note: this flow is only for reference; please find the more detailed installation steps in this section.

8.2 Installation Parts-checking

No.	Name	No.	Name
1	Indoor unit	8	Sealing gum
2	Outdoor unit	9	Wrapping tape
3	Connection pipe	10	Support of outdoor unit
4	Drainage pipe	11	Fixing screw
5	Wall-mounting frame	12	Drainage plug(cooling and heating unit)
6	Connecting cable(power cord)	13	Owners manual, remote controller
7	Wall pipe		

⚠ Note:

1. Please contact the local agent for installation.
2. Don't use unqualified power cord.

8.3 Selection of Installation Location

1. Basic Requirement:

Installing the unit in the following places may cause malfunction. If it is unavoidable, please consult the local dealer:

- (1) The place with strong heat sources, vapors, flammable or explosive gas, or volatile objects spread in the air.
- (2) The place with high-frequency devices (such as welding machine, medical equipment).
- (3) The place near coast area.
- (4) The place with oil or fumes in the air.
- (5) The place with sulfured gas.
- (6) Other places with special circumstances.
- (7) The appliance shall not be installed in the laundry.

2. Indoor Unit:

- (1) There should be no obstruction near air inlet and air outlet.
- (2) Select a location where the condensation water can be dispersed easily and won't affect other people.
- (3) Select a location which is convenient to connect the outdoor unit and near the power socket.
- (4) Select a location which is out of reach for children.
- (5) The location should be able to withstand the weight of indoor unit and won't increase noise and vibration.
- (6) The appliance must be installed 2.5m above floor.
- (7) Don't install the indoor unit right above the electric appliance.
- (8) Please try your best to keep away from fluorescent lamp.

3. Outdoor Unit:

- (1) Select a location where the noise and outflow air emitted by the outdoor unit will not affect neighborhood.
- (2) The location should be well ventilated and dry, in which the outdoor unit won't be exposed directly to sunlight or strong wind.
- (3) The location should be able to withstand the weight of outdoor unit.
- (4) Make sure that the installation follows the requirement of installation dimension diagram.
- (5) Select a location which is out of reach for children and far away from animals or plants. If it is unavoidable, please add fence for safety purpose.

8.4 Requirements for electric connection

1. Safety Precaution

- (1) Must follow the electric safety regulations when installing the unit.
- (2) According to the local safety regulations, use qualified power supply circuit and air switch.
- (3) Make sure the power supply matches with the requirement of air conditioner. Unstable power supply or incorrect wiring may result in electric shock, fire hazard or malfunction. Please install proper power supply cables before using the air conditioner.

Air-conditioner	Air switch capacity
09K	9A
12K GWH18QD-K6DNB4B	13A
18K	16A

- (4) Properly connect the live wire, neutral wire and grounding wire of power socket.
- (5) Be sure to cut off the power supply before proceeding any work related to electricity and safety.
- (6) Do not put through the power before finishing installation.
- (7) If the supply cord is damaged, it must be replaced by the manufacturer, its service agent or similarly qualified persons in order to avoid a hazard.
- (8) The temperature of refrigerant circuit will be high, please keep the interconnection cable away from the copper tube.
- (9) The appliance shall be installed in accordance with national wiring regulations.
- (10) Appliance shall be installed, operated and stored in a room with a floor area larger than "X"m (see table a).



Please notice that the unit is filled with flammable gas R32. Inappropriate treatment of the unit involves the risk of severe damages of people and material. Details to this refrigerant are found in chapter "refrigerant".

2. Grounding Requirement:

- (1) The air conditioner is first class electric appliance. It must be properly grounded with specialized grounding device by a professional. Please make sure it is always grounded effectively, otherwise it may cause electric shock.
- (2) The yellow-green wire in air conditioner is grounding wire, which can't be used for other purposes.
- (3) The grounding resistance should comply with national electric safety regulations.
- (4) The appliance must be positioned so that the plug is accessible.
- (5) An all-pole disconnection switch having a contact separation of at least 3mm in all poles should be connected in fixed wiring.
- (6) Including an air switch with suitable capacity, please note the following table. Air switch should be included magnet buckle and heating buckle function, it can protect the circuit-short and overload. (Caution: please do not use the fuse only for protect the circuit)

8.5 Installation of Indoor Unit

1. Choosing Installation location

Recommend the installation location to the client and then confirm it with the client.

2. Install Wall-mounting Frame

(1) Hang the wall-mounting frame on the wall; adjust it in horizontal position with the level meter and then point out the screw fixing holes on the wall.

(2) Drill the screw fixing holes on the wall with impact drill (the specification of drill head should be the same as the plastic expansion particle) and then fill the plastic expansion particles in the holes.

(3) Fix the wall-mounting frame on the wall with tapping screws (ST4.2X25TA) and then check if the frame is firmly installed by pulling the frame. If the plastic expansion particle is loose, please drill another fixing hole nearby.

3. Install Wall-mounting Frame

(1) Choose the position of piping hole according to the direction of outlet pipe. The position of piping hole should be a little lower than the wall-mounted frame. (As show in Fig.1)

09K:

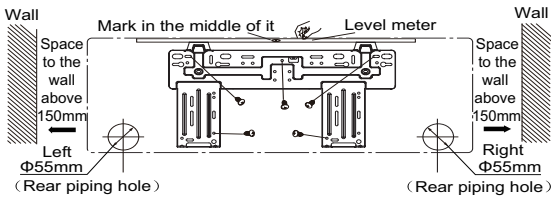

12K:

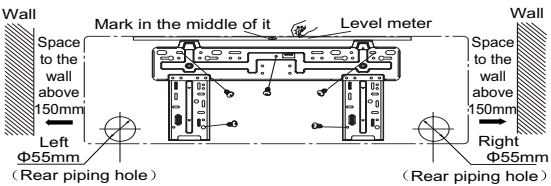

18K:

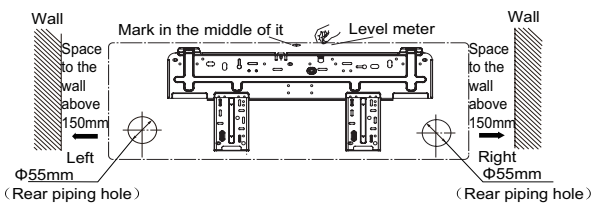

Fig.1

(2) Open a piping hole with the diameter of Φ55mm on the selected outlet pipe position. In order to drain smoothly, slant the piping hole on the wall slightly downward to the outdoor side with the gradient of 5-10°. (As show in Fig.2)

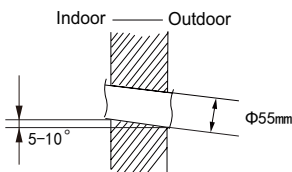

Fig.2

⚠ Note:

- (1) Pay attention to dust prevention and take relevant safety measures when opening the hole.
- (2) The plastic expansion particles are not provided and should be bought locally.

4. Outlet pipe

(1) The pipe can be led out in the direction of right, rear right, left or rear left. (As show in Fig.3)

(2) When selecting leading out the pipe from left or right, please cut off the corresponding hole on the bottom case. (As show in Fig.4)

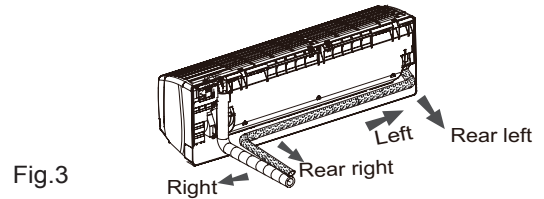

Fig.3

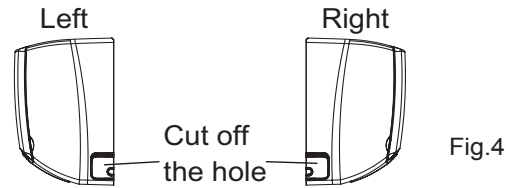

Fig.4

5. Connect the Pipe of Indoor Unit

(1) Aim the pipe joint at the corresponding bellmouth. (As show in Fig.5)

(2) Pretightening the union nut with hand.

(3) Adjust the torque force by referring to the following sheet. Place the open-end wrench on the pipe joint and place the torque wrench on the union nut. Tighten the union nut with torque wrench. (As show in Fig.6)

(4) Wrap the indoor pipe and joint of connection pipe with insulating pipe, and then wrap it with tape. (As show in Fig.7)

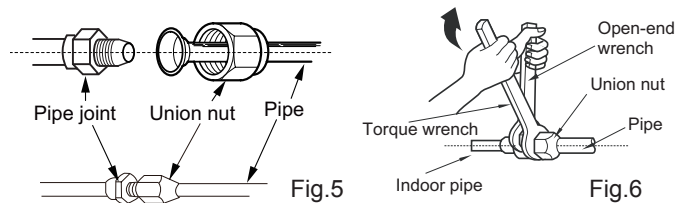

Fig.5

Fig.6

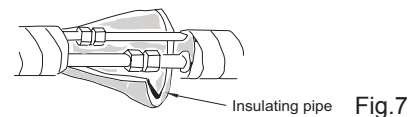

Fig.7

Refer to the following table for wrench moment of force:

Hex nut diameter(mm)	Tightening torque(N·m)
Φ6	15~20
Φ9.52	30~40
Φ12	45~55
Φ16	60~65
Φ19	70~75

6. Install Drain Hose

(1) Connect the drain hose to the outlet pipe of indoor unit. (As show in Fig.8)

(2) Bind the joint with tape. (As show in Fig.9)

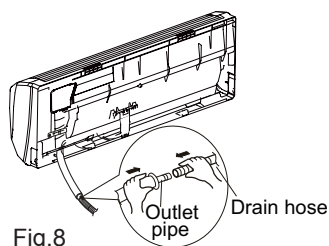

Fig.8

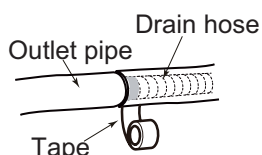

Fig.9

Note:

- (1) Add insulating pipe in the indoor drain hose in order to prevent condensation.
- (2) The plastic expansion particles are not provided. (As show in Fig.10)

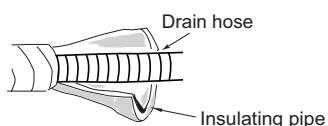

Fig.10

7. Connect Wire of Indoor Unit

- (1) Open the panel, remove the screw on the wiring cover and then take down the cover.(As show in Fig.11)

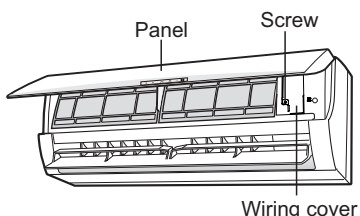

Fig.11

- (2) Make the power connection wire go through the cable-cross hole at the back of indoor unit and then pull it out from the front side.(As show in Fig.12)

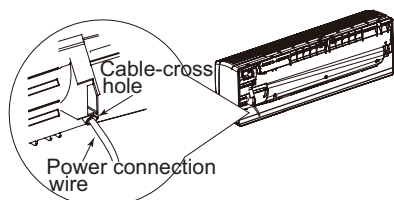
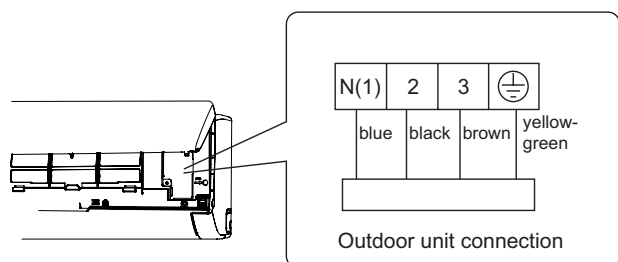

Fig.12

- (3) Remove the wire clip; connect the power connection wire to the wiring terminal according to the color; tighten the screw and then fix the power connection wire with wire clip.(As show in Fig.13)



Note: the wiring board is for reference only, please refer to the actual one.

Fig.13

- (4) Put wiring cover back and then tighten the screw.
- (5) Close the panel.

Note:

- (1) All wires of indoor unit and outdoor unit should be connected by a professional.
- (2) If the length of power connection wire is insufficient, please contact the supplier for a new one. Avoid extending the wire by yourself.
- (3) For the air conditioner with plug, the plug should be reachable after finishing installation.
- (4) For the air conditioner without plug, an air switch must be installed in the line. The air switch should be all-pole parting and the contact parting distance should be more than 3mm.

8. Bind up Pipe

- (1) Bind up the connection pipe, power cord and drain hose with the band.(As show in Fig.14)
- (2) Reserve a certain length of drain hose and power cord for installation when binding them. When binding to a certain degree, separate the indoor power and then separate the drain hose.(As show in Fig.15)
- (3) Bind them evenly.
- (4) The liquid pipe and gas pipe should be bound separately at the end.

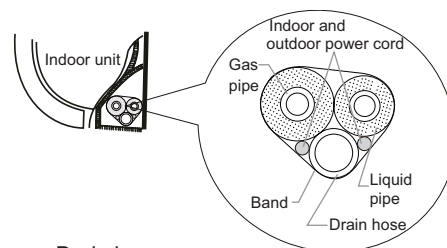

Fig.14

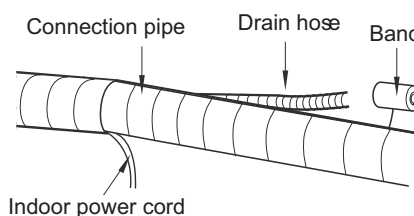

Fig.15

Note:

- (1) The power cord and control wire cant be crossed or winding.
- (2) The drain hose should be bound at the bottom.

9. Hang the Indoor Unit

- (1) Put the bound pipes in the wall pipe and then make them pass through the wall hole.
- (2) Hang the indoor unit on the wall-mounting frame.
- (3) Stuff the gap between pipes and wall hole with sealing gum.
- (4) Fix the wall pipe.(As show in Fig.16)
- (5) Check if the indoor unit is installed firmly and closed to the wall.(As show in Fig.17)

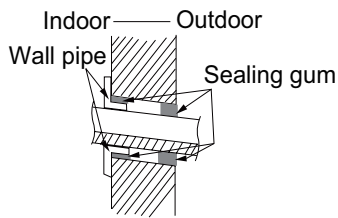

Fig.16

⚠ Note:

Do not bend the drain hose too excessively in order to prevent blocking.

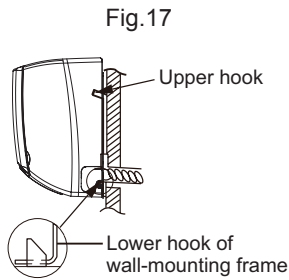

Fig.17

8.6 Installation of Outdoor Unit

1. Fix the Support of Outdoor Unit(Select it according to the actual installation situation)

- (1) Select installation location according to the house structure.
- (2) Fix the support of outdoor unit on the selected location with expansion screws.

⚠ Note:

- (1) Take sufficient protective measures when installing the outdoor unit.
- (2) Make sure the support can withstand at least four times the unit weight.
- (3) The outdoor unit should be installed at least 3cm above the floor in order to install drain joint.(As show in Fig.18)
- (4) For the unit with cooling capacity of 2300W~5000W, 6 expansion screws are needed; for the unit with cooling capacity of 6000W~8000W, 8 expansion screws are needed; for the unit with cooling capacity of 10000W~16000W, 10 expansion screws are needed.

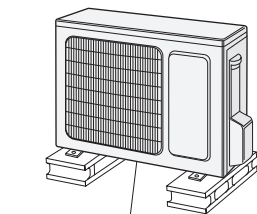

Fig.18

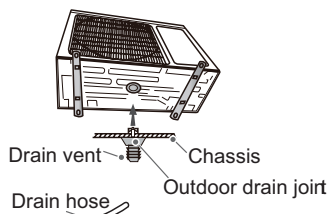

Fig.19

2. Install Drain Joint(Only for cooling and heating unit)

- (1) Connect the outdoor drain joint into the hole on the chassis.
 - (2) Connect the drain hose into the drain vent.
- (As show in Fig.19)

3. Fix Outdoor Unit

- (1) Place the outdoor unit on the support.
 - (2) Fix the foot holes of outdoor unit with bolts.
- (As show in Fig.20)

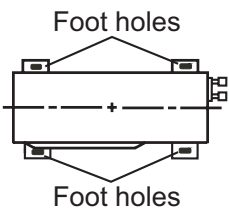

Fig.20

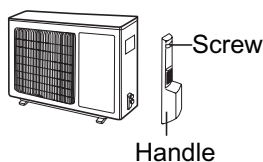

Fig.21

4. Connect Indoor and Outdoor Pipes

- (1) Remove the screw on the right handle of outdoor unit and then remove the handle.(As show in Fig.21)
- (2) Remove the screw cap of valve and aim the pipe joint at the bellmouth of pipe.(As show in Fig.22)

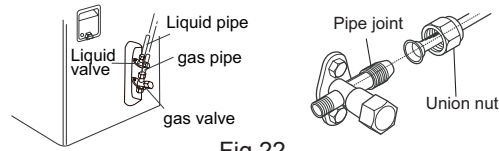

Fig.22

- (3) Pretightening the union nut with hand.
- (4) Tighten the union nut with torque wrench .

Refer to the following table for wrench moment of force:

Hex nut diameter(mm)	Tightening torque(N·m)
Φ6	15~20
Φ9.52	30~40
Φ12	45~55
Φ16	60~65
Φ19	70~75

5. Connect Outdoor Electric Wire

- (1) Remove the wire clip; connect the power connection wire and signal control wire (only for cooling and heating unit) to the wiring terminal according to the color; fix them with screws.(As show in Fig.23)

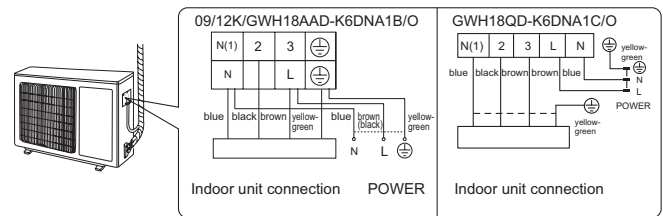

Note: the wiring board is for reference only, please refer to the actual one.

Fig.23

- (2) Fix the power connection wire and signal control wire with wire clip (only for cooling and heating unit).

⚠ Note:

- (1) After tightening the screw, pull the power cord slightly to check if it is firm.
- (2) Never cut the power connection wire to prolong or shorten the distance.

6. Neaten the Pipes

- (1) The pipes should be placed along the wall, bent reasonably and hidden possibly. Min. semidiameter of bending the pipe is 10cm.
- (2) If the outdoor unit is higher than the wall hole, you must set a U-shaped curve in the pipe before pipe goes into the room, in order to prevent rain from getting into the room.(As show in Fig.24)

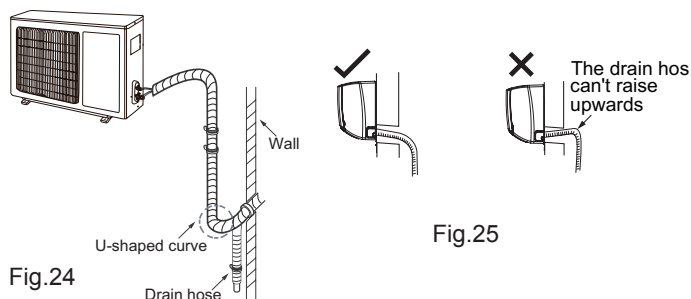

Fig.25

⚠ Note:

- (1) The through-wall height of drain hose shouldnt be higher than the outlet pipe hole of indoor unit.(As show in Fig.25)
- (2) Slant the drain hose slightly downwards. The drain hose cant be curved, raised and fluctuant, etc.(As show in Fig.26)
- (3) The water outlet cant be placed in water in order to drain smoothly.(As show in Fig.27)

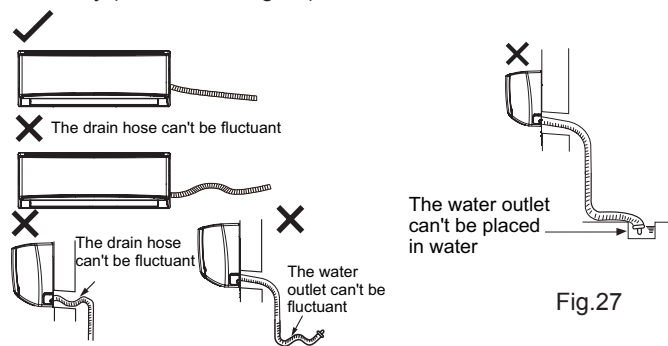

Fig.26

8.7 Vacuum Pumping and Leak Detection

1. Use Vacuum Pump

- (1) Remove the valve caps on the liquid valve and gas valve and the nut of refrigerant charging vent.
- (2) Connect the charging hose of piezometer to the refrigerant charging vent of gas valve and then connect the other charging hose to the vacuum pump.
- (3) Open the piezometer completely and operate for 10-15min to check if the pressure of piezometer remains in -0.1MPa.
- (4) Close the vacuum pump and maintain this status for 1-2min to check if the pressure of piezometer remains in -0.1MPa. If the pressure decreases, there may be leakage.
- (5) Remove the piezometer, open the valve core of liquid valve and gas valve completely with inner hexagon spanner.
- (6) Tighten the screw caps of valves and refrigerant charging vent.(As show in Fig.28)

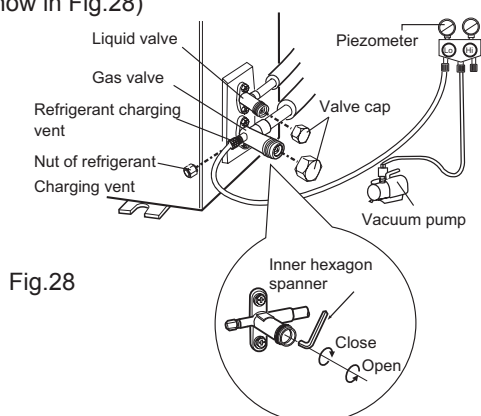

Fig.28

2. Leakage Detection

- (1) With leakage detector: Check if there is leakage with leakage detector.
- (2) With soap water: If leakage detector is not available, please use soap water for leakage detection. Apply soap water at the suspected position and keep the soap water for more than 3min. If there are air bubbles coming out of this position, theres a leakage.

8.8 Check after Installation and Test Operation

1. Check after Installation

Check according to the following requirement after finishing installation.

NO.	Items to be checked	Possible malfunction
1	Has the unit been installed firmly?	The unit may drop, shake or emit noise.
2	Have you done the refrigerant leakage test?	It may cause insufficient cooling (heating) capacity.
3	Is heat insulation of pipeline sufficient?	It may cause condensation and water dripping.
4	Is water drained well?	It may cause condensation and water dripping.
5	Is the voltage of power supply according to the voltage marked on the nameplate?	It may cause malfunction or damage the parts.
6	Is electric wiring and pipeline installed correctly?	It may cause malfunction or damage the parts.
7	Is the unit grounded securely?	It may cause electric leakage.
8	Does the power cord follow the specification?	It may cause malfunction or damage the parts.
9	Is there any obstruction in air inlet and air outlet?	It may cause insufficient cooling (heating) capacity.
10	The dust and sundries caused during installation are removed?	It may cause malfunction or damaging the parts.
11	The gas valve and liquid valve of connection pipe are open completely?	It may cause insufficient cooling (heating) capacity.
12	Is the inlet and outlet of piping hole been covered?	It may cause insufficient cooling (heating) capacity or waster eletricity.

2. Test Operation

- (1) Preparation of test operation
 - The client approves the air conditioner installation.
 - Specify the important notes for air conditioner to the client.
- (2) Method of test operation
 - Put through the power, press ON/OFF button on the remote controller to start operation.
 - Press MODE button to select AUTO, COOL, DRY, FAN and HEAT to check whether the operation is normal or not.
 - If the ambient temperature is lower than 16°C , the air conditioner cant start cooling.

9. Maintenance

9.1 Error Code List

Note: All models except 18K

NO.	Malfunction Name	Display Method of Indoor Unit			A/C status	Possible Causes	
		Dual-8 Code Display	Indicator Display (during blinking, ON 0.5s and OFF 0.5s)				
			Operation Indicator	Cool Indicator			Heating Indicator
1	High pressure protection of system	E1				During cooling and drying operation, except indoor fan operates, all loads stop operation. During heating operation, the complete unit stops.	Possible reasons: 1. Refrigerant was superabundant; 2. Poor heat exchange (including filth blockage of heat exchanger and bad radiating environment); Ambient temperature is too high.
2	Antifreezing protection	E2				During cooling and drying operation, compressor and outdoor fan stop while indoor fan operates.	1. Poor air-return in indoor unit; 2. Fan speed is abnormal; 3. Evaporator is dirty.
3	In defect of refrigerant	F0				The Dual-8 Code Display will show F0 and the complete unit stops.	1. In defect of refrigerant; 2. Indoor evaporator temperature sensor works abnormally; 3. The unit has been plugged up somewhere.
4	High discharge temperature protection of compressor	E4				During cooling and drying operation, compressor and outdoor fan stop while indoor fan operates. During heating operation, all loads stop.	Please refer to the malfunction analysis (discharge protection, overload).
5	Overcurrent protection	E5				During cooling and drying operation, compressor and outdoor fan stop while indoor fan operates. During heating operation, all loads stop.	1. Supply voltage is unstable; 2. Supply voltage is too low and load is too high; 3. Evaporator is dirty.
6	Communication Malfunction	E6				During cooling operation, compressor stops while indoor fan motor operates. During heating operation, the complete unit stops.	Refer to the corresponding malfunction analysis.
7	High temperature resistant protection	E8				During cooling operation: compressor will stop while indoor fan will operate. During heating operation, the complete unit stops.	Refer to the malfunction analysis (overload, high temperature resistant).
8	EEPROM malfunction	EE				During cooling and drying operation, compressor will stop while indoor fan will operate; During heating operation, the complete unit will stop	Replace outdoor control panel AP1
9	Limit/decrease frequency due to high temperature of module	EU				All loads operate normally, while operation frequency for compressor is decreased	Discharging after the complete unit is de-energized for 20mins, check whether the thermal grease on IPM Module of outdoor control panel AP1 is sufficient and whether the radiator is inserted tightly. If its no use, please replace control panel AP1.
10	Malfunction protection of jumper cap	C5				Wireless remote receiver and button are effective, but can not dispose the related command	1. No jumper cap insert on mainboard. 2. Incorrect insert of jumper cap. 3. Jumper cap damaged. 4. Abnormal detecting circuit of mainboard.

NO.	Malfunction Name	Display Method of Indoor Unit			A/C status	Possible Causes	
		Dual-8 Code Display	Indicator Display (during blinking, ON 0.5s and OFF 0.5s)	Operation Indicator			Cool Indicator
11	Gathering refrigerant	F0				When the outdoor unit receive signal of Gathering refrigerant ,the system will be forced to run under cooling mode for gathering refrigerant	Nominal cooling mode
12	Indoor ambient temperature sensor is open/short circuited	F1				During cooling and drying operation, indoor unit operates while other loads will stop; during heating operation, the complete unit will stop operation.	<ol style="list-style-type: none"> 1. Loosening or bad contact of indoor ambient temp. sensor and mainboard terminal. 2. Components in mainboard fell down leads short circuit. 3. Indoor ambient temp. sensor damaged.(check with sensor resistance value chart) 4. Mainboard damaged.
13	Indoor evaporator temperature sensor is open/short circuited	F2				AC stops operation once reaches the setting temperature. Cooling, drying: internal fan motor stops operation while other loads stop operation; heating: AC stop operation	<ol style="list-style-type: none"> 1. Loosening or bad contact of Indoor evaporator temp. sensor and mainboard terminal. 2. Components on the mainboard fall down leads short circuit. 3. Indoor evaporator temp. sensor damaged.(check temp. sensor value chart for testing) 4. Mainboard damaged.
14	Outdoor ambient temperature sensor is open/short circuited	F3				During cooling and drying operating, compressor stops while indoor fan operates; During heating operation, the complete unit will stop operation	Outdoor temperature sensor hasnt been connected well or is damaged. Please check it by referring to the resistance table for temperature sensor)
15	Outdoor condenser temperature sensor is open/short circuited	F4				During cooling and drying operation, compressor stops while indoor fan will operate; During heating operation, the complete unit will stop operation.	Outdoor temperature sensor hasnt been connected well or is damaged. Please check it by referring to the resistance table for temperature sensor)
16	Outdoor discharge temperature sensor is open/short circuited	F5				During cooling and drying operation, compressor will sop after operating for about 3 mins, while indoor fan will operate; During heating operation, the complete unit will stop after operating for about 3 mins.	<ol style="list-style-type: none"> 1.Outdoor temperature sensor hasnt been connected well or is damaged. Please check it by referring to the resistance table for temperature sensor) 2.The head of temperature sensor hasnt been inserted into the copper tube
17	Limit/ decrease frequency due to overload	F6				All loads operate normally, while operation frequency for compressor is decreased	Refer to the malfunction analysis (overload, high temperature resistant)
18	Decrease frequency due to overcurrent	F8				All loads operate normally, while operation frequency for compressor is decreased	The input supply voltage is too low; System pressure is too high and overload

NO.	Malfunction Name	Display Method of Indoor Unit				A/C status	Possible Causes
		Dual-8 Code Display	Indicator Display (during blinking, ON 0.5s and OFF 0.5s)				
			Operation Indicator	Cool Indicator	Heating Indicator		
19	Decrease frequency due to high air discharge	F9				All loads operate normally, while operation frequency for compressor is decreased	Overload or temperature is too high; Refrigerant is insufficient; Malfunction of electric expansion valve (EKV)
20	Limit/decrease frequency due to antifreezing	FH				All loads operate normally, while operation frequency for compressor is decreased	Poor air-return in indoor unit or fan speed is too low
21	Voltage for DC bus-bar is too high	PH				During cooling and drying operation, compressor will stop while indoor fan will operate; During heating operation, the complete unit will stop operation.	1. Measure the voltage of position L and N on wiring board (XT), if the voltage is higher than 265VAC, turn on the unit after the supply voltage is increased to the normal range. 2.If the AC input is normal, measure the voltage of electrolytic capacitor C on control panel (AP1), if its normal, theres malfunction for the circuit, please replace the control panel (AP1)
22	Voltage of DC bus-bar is too low	PL				During cooling and drying operation, compressor will stop while indoor fan will operate; During heating operation, the complete unit will stop	1. Measure the voltage of position L and N on wiring board (XT), if the voltage is higher than 150VAC, turn on the unit after the supply voltage is increased to the normal range. 2.If the AC input is normal, measure the voltage of electrolytic capacitor C on control panel (AP1), if its normal, theres malfunction for the circuit, please replace the control panel (AP1)
23	Compressor Min frequency in test state	P0					Showing during min. cooling or min. heating test
24	Compressor rated frequency in test state	P1					Showing during nominal cooling or nominal heating test
25	Compressor maximum frequency in test state	P2					Showing during max. cooling or max. heating test

NO.	Malfunction Name	Display Method of Indoor Unit			A/C status	Possible Causes	
		Dual-8 Code Display	Indicator Display (during blinking, ON 0.5s and OFF 0.5s)				
			Operation Indicator	Cool Indicator			Heating Indicator
26	Compressor intermediate frequency in test state	P3				Showing during middle cooling or middle heating test	
27	Overcurrent protection of phase current for compressor	P5				During cooling and drying operation, compressor will stop while indoor fan will operate; During heating operation, the complete unit will stop operation. Refer to the malfunction analysis (IPM protection, loss of synchronism protection and overcurrent protection of phase current for compressor.	
28	Charging malfunction of capacitor	PU				During cooling and drying operation, compressor will stop while indoor fan will operate; During heating operation, the complete unit will stop Refer to the part three—charging malfunction analysis of capacitor	
29	Malfunction of module temperature sensor circuit	P7				During cooling and drying operation, compressor will stop while indoor fan will operate; During heating operation, the complete unit will stop Replace outdoor control panel AP1	
30	Module high temperature protection	P8				During cooling operation, compressor will stop while indoor fan will operate; During heating operation, the complete unit will stop After the complete unit is de-energized for 20mins, check whether the thermal grease on IPM Module of outdoor control panel AP1 is sufficient and whether the radiator is inserted tightly. If its no use, please replace control panel AP1.	
31	Overload protection for compressor	H3				During cooling and drying operation, compressor will stop while indoor fan will operate; During heating operation, the complete unit will stop operation. 1. Wiring terminal OVC-COMP is loosened. In normal state, the resistance for this terminal should be less than 1ohm. 2.Refer to the malfunction analysis (discharge protection, overload)	
32	IPM protection	H5				During cooling and drying operation, compressor will stop while indoor fan will operate; During heating operation, the complete unit will stop operation. Refer to the malfunction analysis (IPM protection, loss of synchronism protection and overcurrent protection of phase current for compressor.	
33	Malfunction of zero-cross detection circuit	U8				The complete unit stops 1.Power supply is abnormal; 2.Detection circuit of indoor control mainboard is abnormal.	

NO.	Malfunction Name	Display Method of Indoor Unit			A/C status	Possible Causes	
		Dual-8 Code Display	Indicator Display (during blinking, ON 0.5s and OFF 0.5s)				
			Operation Indicator	Cool Indicator	Heating Indicator		
34	Internal motor (fan motor) do not operate	H6				Internal fan motor, external fan motor, compressor and electric heater stop operation,guide louver stops at present location.	1. Bad contact of DC motor feedback terminal. 2. Bad contact of DC motor control end. 3. Fan motor is stalling. 4. Motor malfunction. 5. Malfunction of mainboard rev detecting circuit.
35	Desynchronizing of compressor	H7				During cooling and drying operation, compressor will stop while indoor fan will operate; During heating operation, the complete unit will stop operation.	Refer to the malfunction analysis (IPM protection, loss of synchronism protection and overcurrent protection of phase current for compressor.
36	Outdoor DC fan motor malfunction	L3				Outdoor DC fan motor malfunction lead to compressor stop operation,	DC fan motor malfunction or system blocked or the connector loosed
37	power protection	L9				compressor stop operation and Outdoor fan motor will stop 30s latter , 3 minutes latter fan motor and compressor will restart	To protect the electronical components when detect high power
38	Indoor unit and outdoor unit doesnt match	LP				compressor and Outdoor fan motor cant work	Indoor unit and outdoor unit doesnt match
39	Failure start-up	LC				During cooling and drying operation, compressor will stop while indoor fan will operate; During heating operation, the complete unit will stop operation.	Refer to the malfunction analysis
40	Normal communication						
41	Defrosting				OFF 3S and blink once (during blinking, ON 10s and OFF 0.5s)	Defrosting will occur in heating mode. Compressor will operate while indoor fan will stop operation.	Its the normal state
42	Malfunction of phase current detection circuit for compressor	U1				During cooling and drying operation, compressor will stop while indoor fan will operate; During heating operation, the complete unit will stop	Replace outdoor control panel AP1
43	Malfunction of voltage dropping for DC bus-bar	U3				During cooling and drying operation, compressor will stop while indoor fan will operate; During heating operation, the complete unit will stop	Supply voltage is unstable

NO.	Malfunction Name	Display Method of Indoor Unit			A/C status	Possible Causes	
		Dual-8 Code Display	Indicator Display (during blinking, ON 0.5s and OFF 0.5s)				
			Operation Indicator	Cool Indicator	Heating Indicator		
44	Malfunction of complete units current detection	U5				During cooling and drying operation, the compressor will stop while indoor fan will operate; During heating operating, the complete unit will stop operation.	Theres circuit malfunction on outdoor units control panel AP1, please replace the outdoor units control panel AP1.
45	The four-way valve is abnormal	U7				If this malfunction occurs during heating operation, the complete unit will stop operation.	1. Supply voltage is lower than AC175V; 2. Wiring terminal 4V is loosened or broken; 3. 4V is damaged, please replace 4V.
46	Frequency limiting (power)						
47	Compressor is open-circuited						
48	The temperature for turning on the unit is reached						
49	Frequency limiting (module temperature)						
50	Malfunction of detecting plate(WIFI)	JF					
51	PFC protection	HC				During cooling and drying operation, compressor will stop while indoor fan will operate; During heating operation, the complete unit will stop operation	Replace outdoor control panel AP1 or Reactor
52	In defect of refrigerant	F0				The Dual-8 Code Display will show F0 and the complete unit stops.	1. In defect of refrigerant; 2. Indoor evaporator temperature sensor works abnormally; 3. The unit has been plugged up somewhere.

If malfunction occurs, corresponding code will display and the unit will resume normal until protection or malfunction disappears.

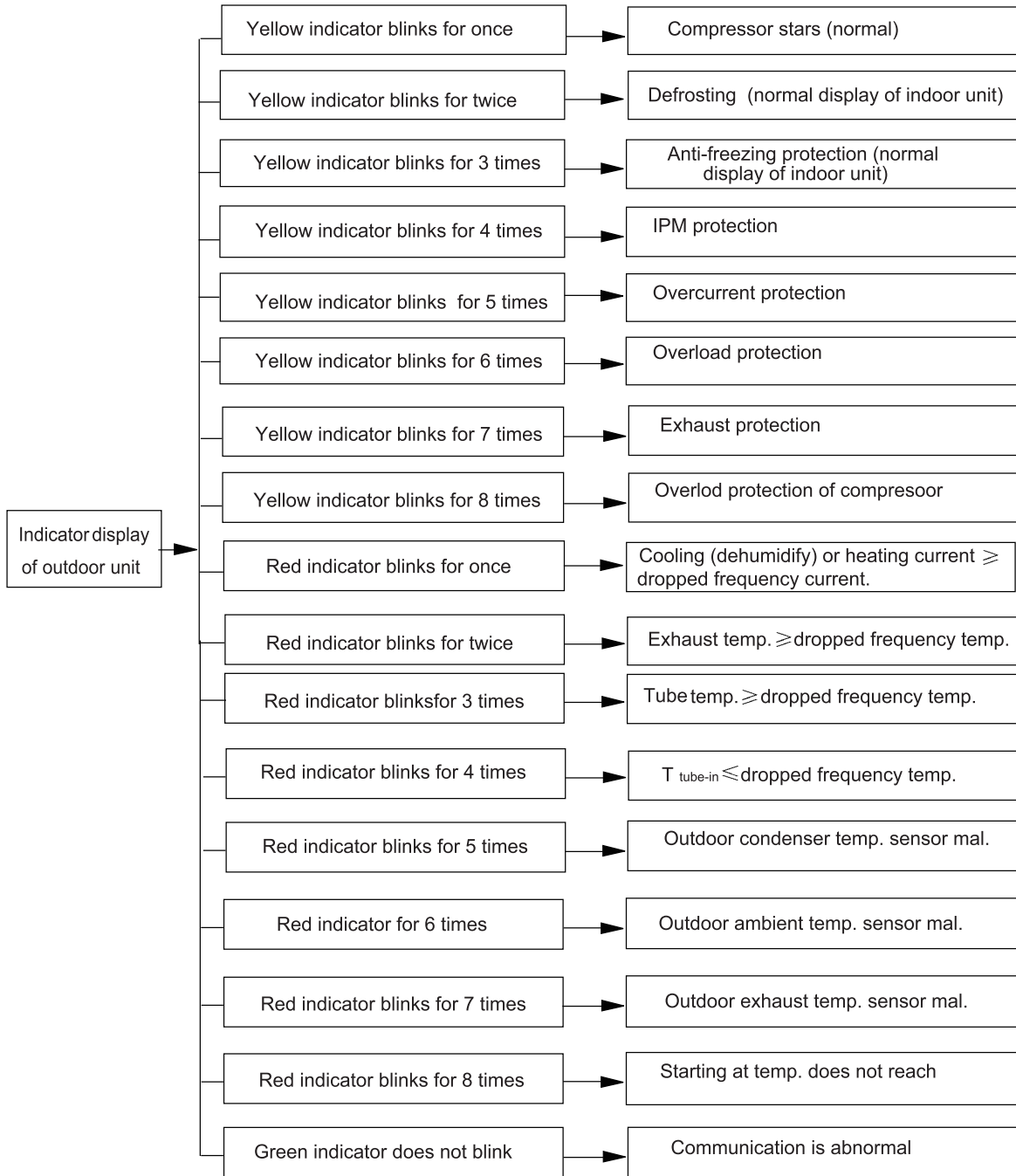

Analysis or processing of some of the malfunction display:

1. Compressor discharge protection

Possible causes: shortage of refrigerant; blockage of air filter; poor ventilation or air flow short pass for condenser; the system has noncondensing gas (such as air, water etc.); blockage of capillary assy (including filter); leakage inside four-way valve causes incorrect operation; malfunction of compressor; malfunction of protection relay; malfunction of discharge sensor; outdoor temperature too high.

Processing method: refer to the malfunction analysis in the above section.

2. Low voltage overcurrent protection

Possible cause: Sudden drop of supply voltage.

3.

Processing method: Check if communication signal cable is connected reliably.

4. Sensor open or short circuit

Processing method: Check whether sensor is normal, connected with the corresponding position on the controller and if damage of lead wire is found.

5. Compressor over load protection

Possible causes: insufficient or too much refrigerant; blockage of capillary and increase of suction temp.; improper running of compressor, burning in or stuck of bearing, damage of discharge valve; malfunction of protector.

Processing method: adjust refrigerant amount; replace the capillary; replace the compressor; use universal meter to check if the contactor of compressor is fine when it is not overheated, if not replace the protector.

6. System malfunction

i.e. overload protection. When tube temperature (Check the temperature of outdoor heat exchanger when cooling and check the temperature of indoor heat exchanger when heating) is too high, protection will be activated.

Possible causes: Outdoor temperature is too high when cooling; insufficient outdoor air circulation; refrigerant flow malfunction.

please refer to the malfunction analysis in the previous section for handling method.

7. IPM module protection

Processing method: Once the module malfunction happens, if it persists for a long time and can not be self-canceled, cut off the power and turn off the unit, and then re-energize the unit again after about 10 min. After repeating the procedure for several times, if the malfunction still exists, replace the module.

9.2 Procedure of Troubleshooting

Indoor unit

(1) Malfunction of Temperature Sensor F1, F2

Main detection points:

- Is the wiring terminal between the temperature sensor and the controller loosened or poorly contacted?
- Is there short circuit due to trip-over of the parts?
- Is the temperature sensor broken?
- Is mainboard broken?

Malfunction diagnosis process:

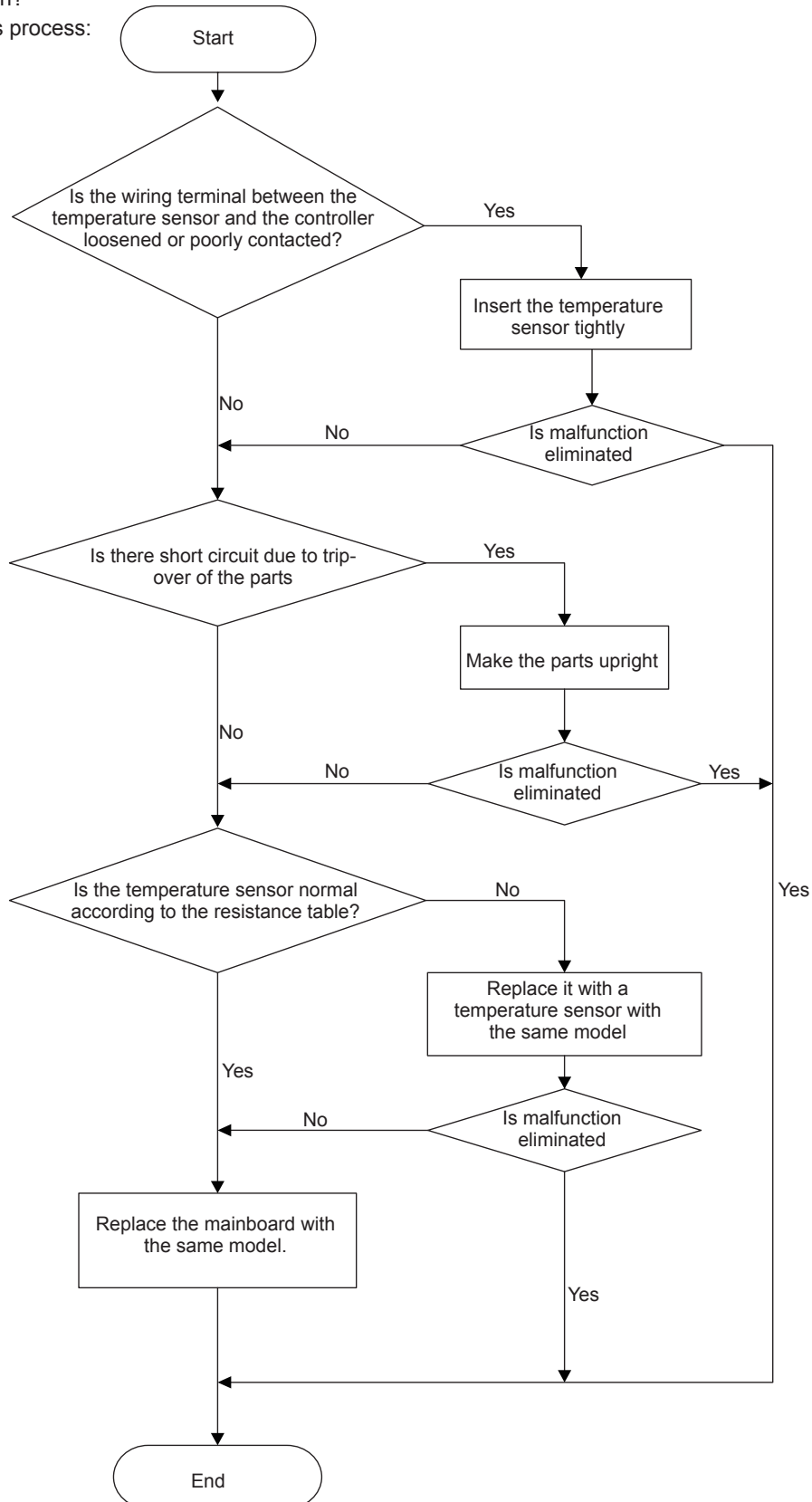

(2) Malfunction of Blocked Protection of IDU Fan Motor H6

Main detection points:

- Smoothly the control terminal of PG motor connected tightly?
- Smoothly the feedback interface of PG motor connected tightly?
- The fan motor cant operate?
- The motor is broken?
- Detection circuit of the mainboard is defined abnormal?

Malfunction diagnosis process:

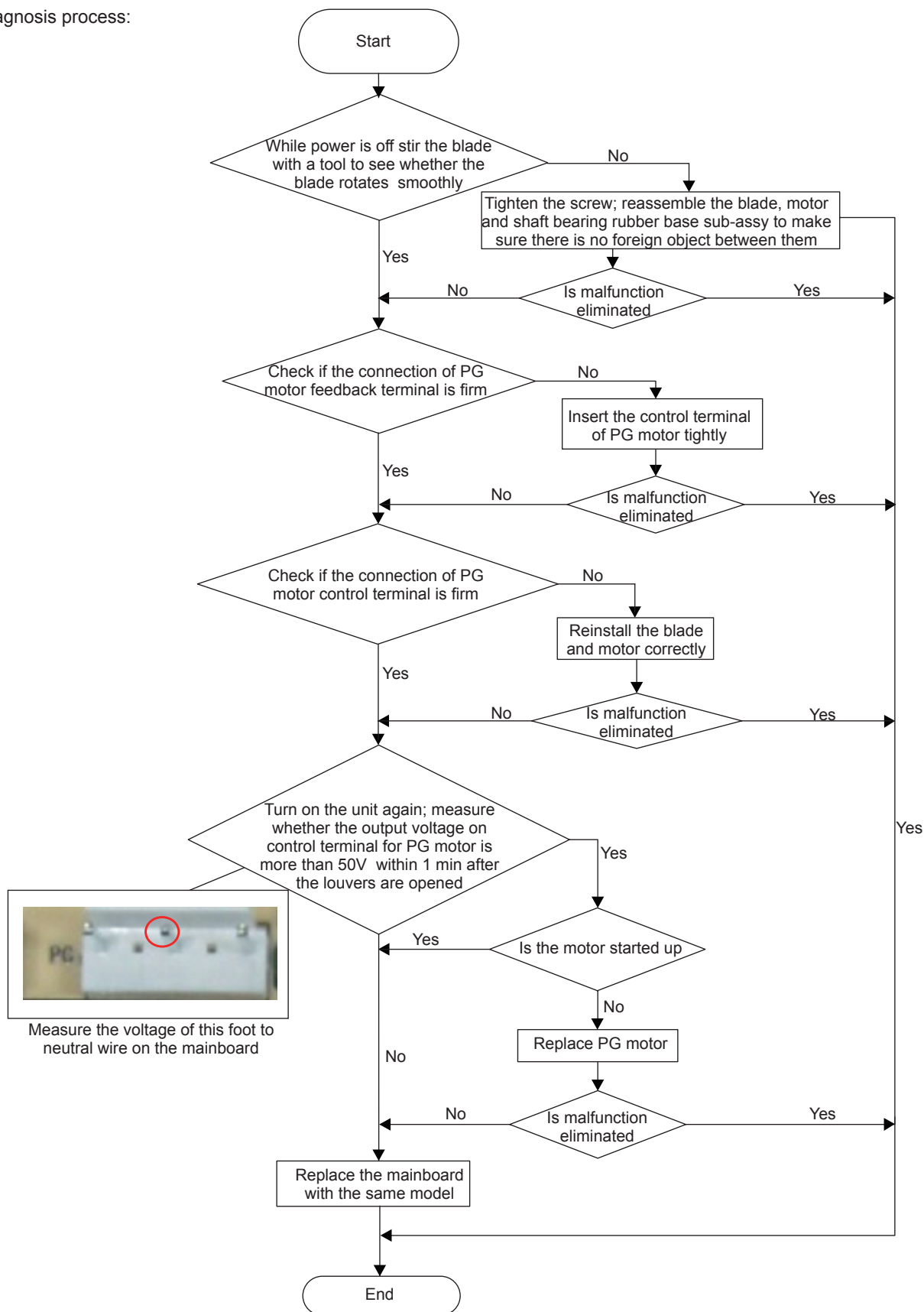

(3) Malfunction of Protection of Jumper Cap C5

Main detection points:

- Is there jumper cap on the mainboard?
- Is the jumper cap inserted correctly and tightly?
- The jumper is broken?
- The motor is broken?
- Detection circuit of the mainboard is defined abnormal?

Malfunction diagnosis process:

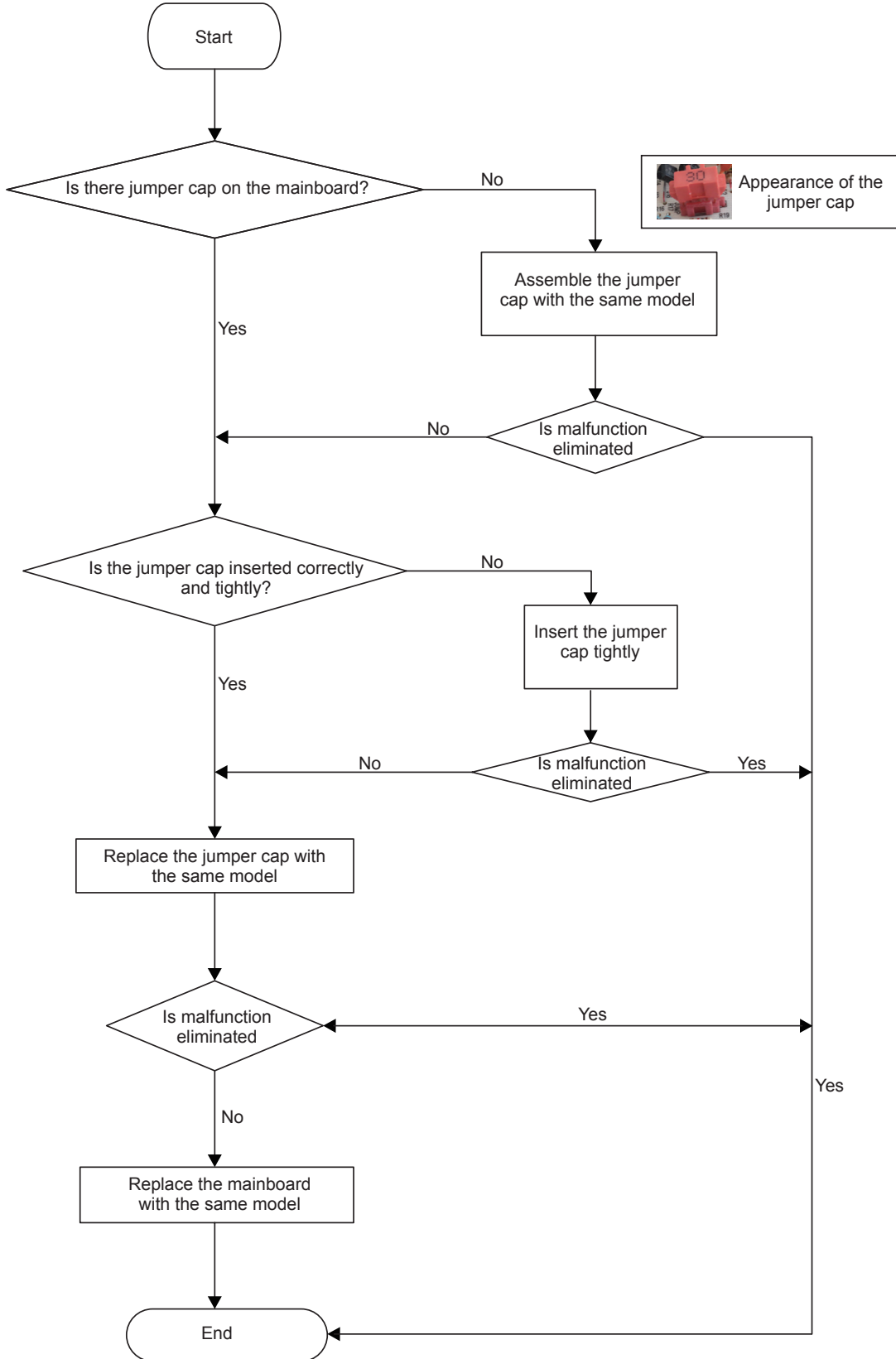

Appearance of the jumper cap

(4) Malfunction of Zero-crossing Inspection Circuit Malfunction of the IDU Fan Motor U8

Main detection points:

- Instant energization after de-energization while the capacitor discharges slowly?
- The zero-cross detection circuit of the mainboard is defined abnormal?

Malfunction diagnosis process:

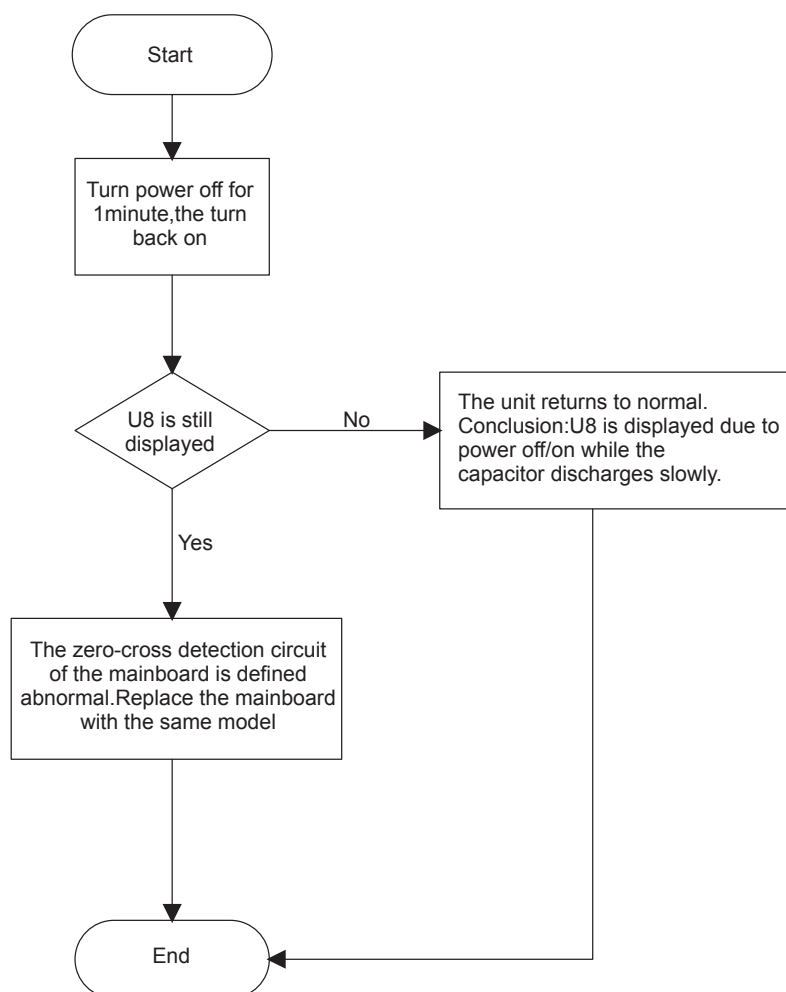

Outdoor unit:

(1) Capacitor charge fault (Fault with outdoor unit) (AP1 below refers to the outdoor control panel)

Main Check Points:

- Use AC voltmeter to check if the voltage between terminal L and N on the wiring board is within 210VAC~240VAC.
- Is the reactor (L) correctly connected? Is the connection loose or fallen? Is the reactor (L) damaged?

Fault diagnosis process:

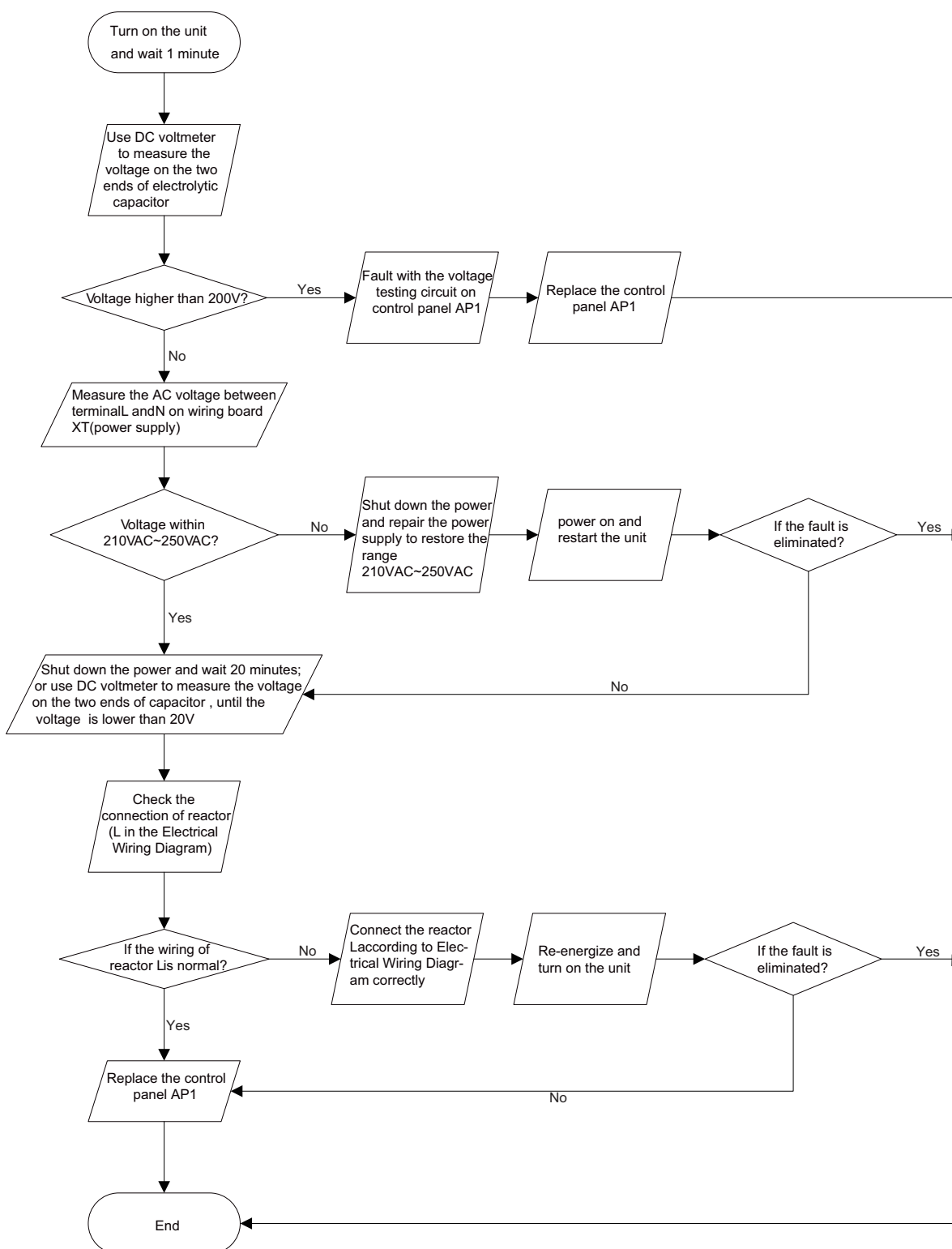

(2) IPM protection, phase current overcurrent (the control board as below indicates the control board of outdoor unit) H5/P5

Mainly detect:

- (1) Compressor COMP terminal (2) voltage of power supply (3) compressor
- (4) Refrigerant-charging volume (5) air outlet and air inlet of outdoor/indoor unit

Troubleshooting:

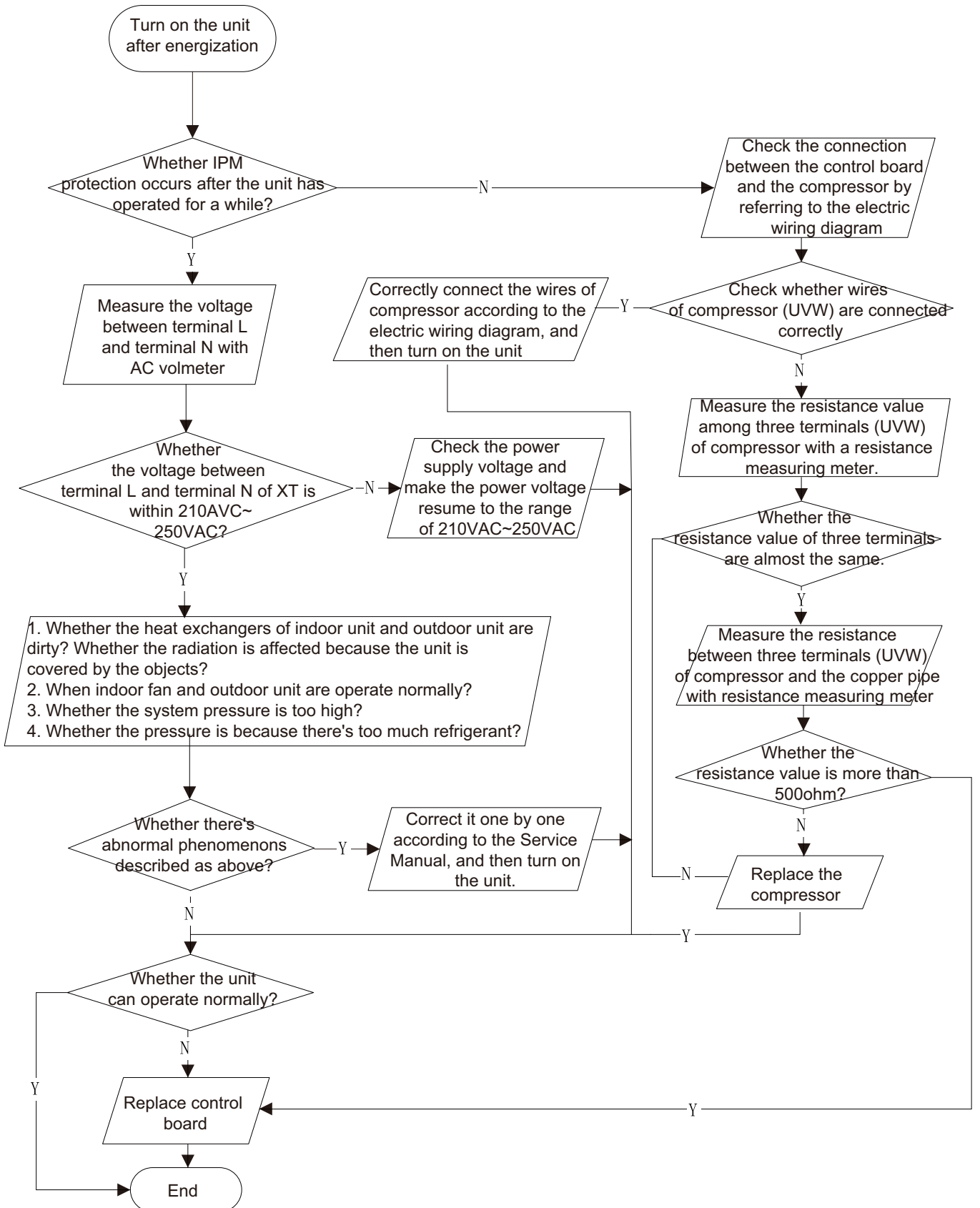

(3) High temperature and overload protection diagnosis (AP1 hereinafter refers to the control board of the outdoor unit)

Mainly detect:

- Is outdoor ambient temperature in normal range?
- Are the outdoor and indoor fans operating normally?
- Is the heat dissipation environment inside and outside the unit good?

Fault diagnosis process:

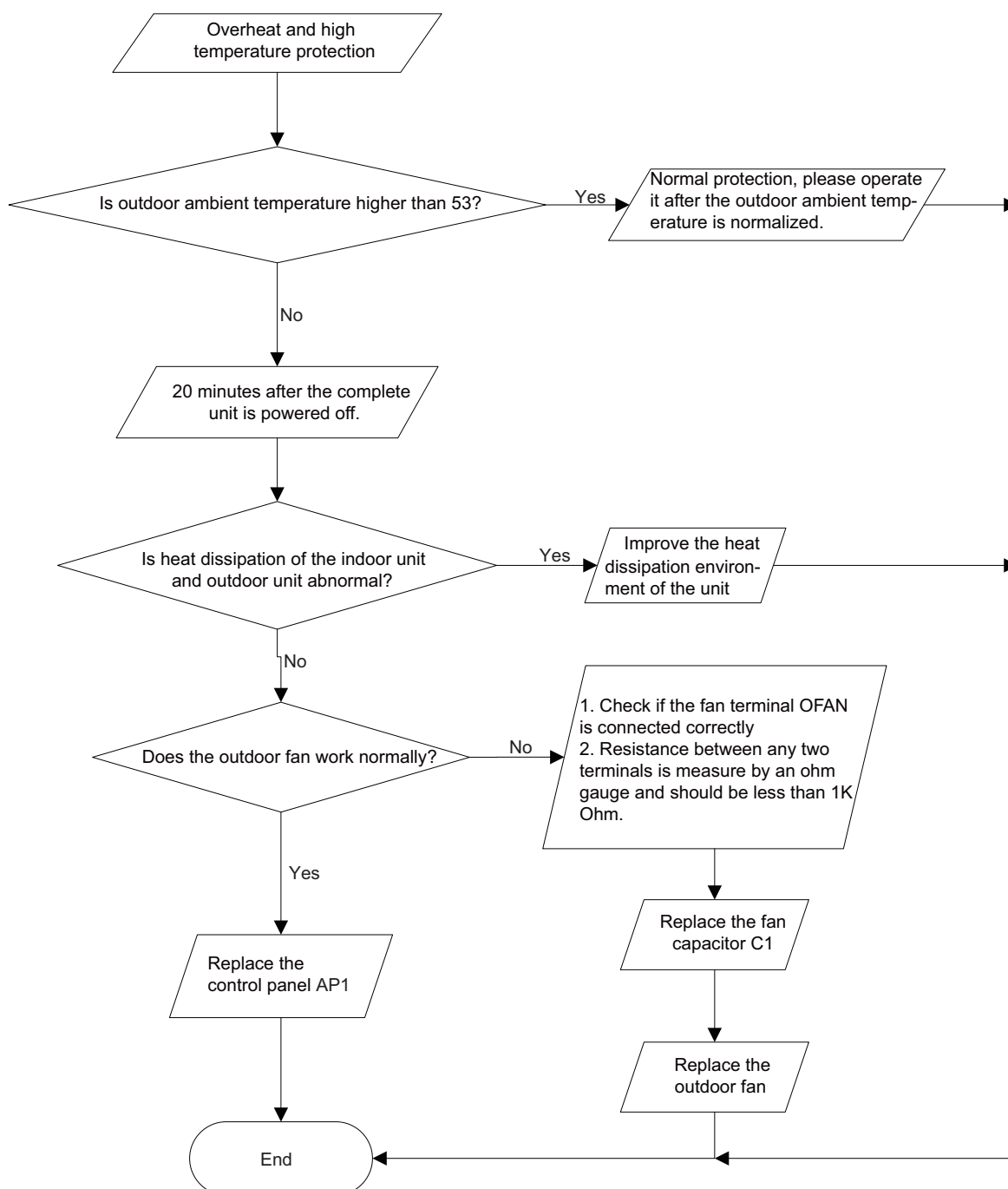

(4) Start-up failure (following AP1 for outdoor unit control board)

Mainly detect:

- Whether the compressor wiring is connected correct?
- Is compressor broken?
- Is time for compressor stopping enough?

Fault diagnosis process:

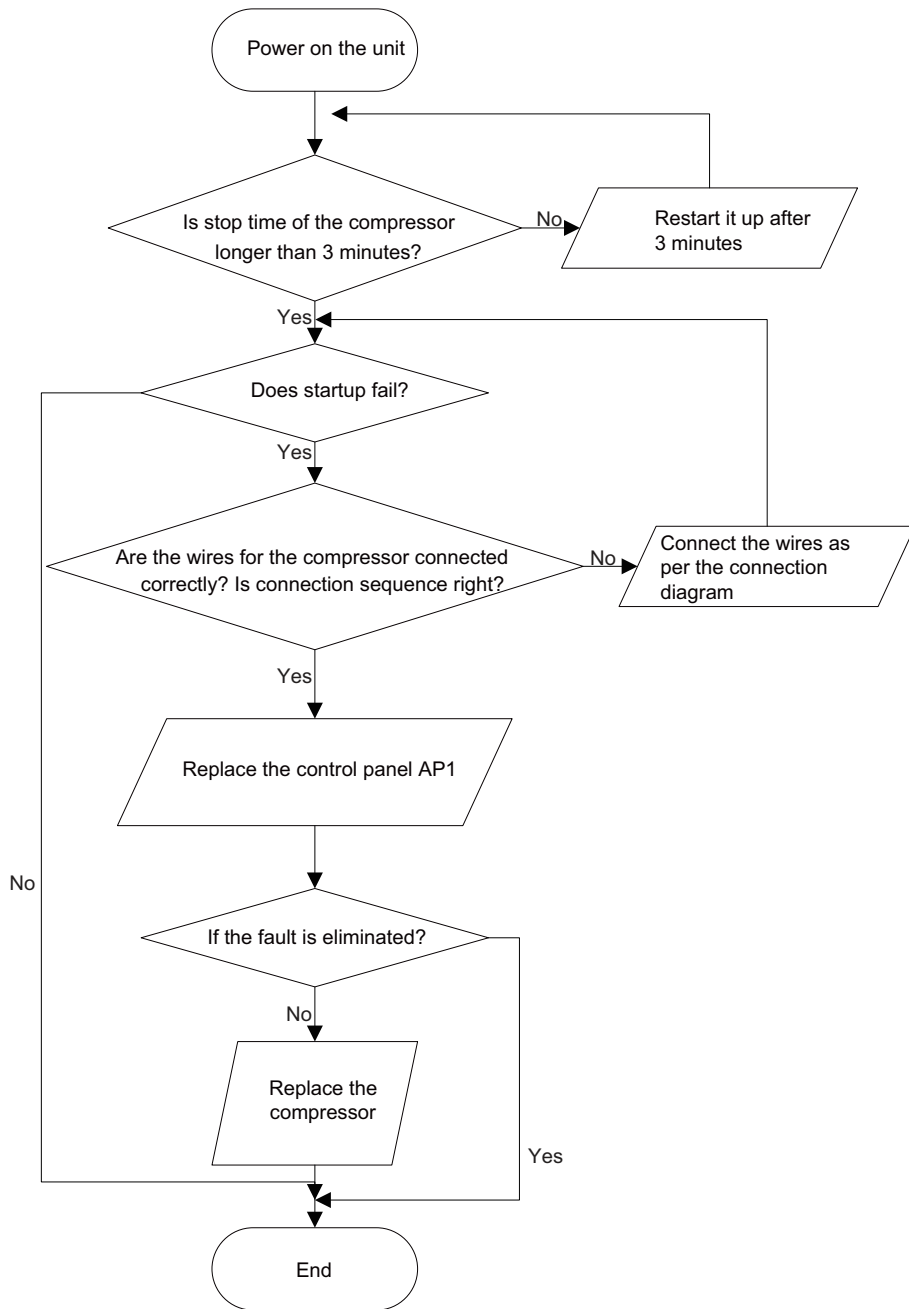

(5) Out of step diagnosis for the compressor (AP1 hereinafter refers to the control board of the outdoor unit)

Mainly detect:

- Is the system pressure too high?
- Is the input voltage too low?

Fault diagnosis process:

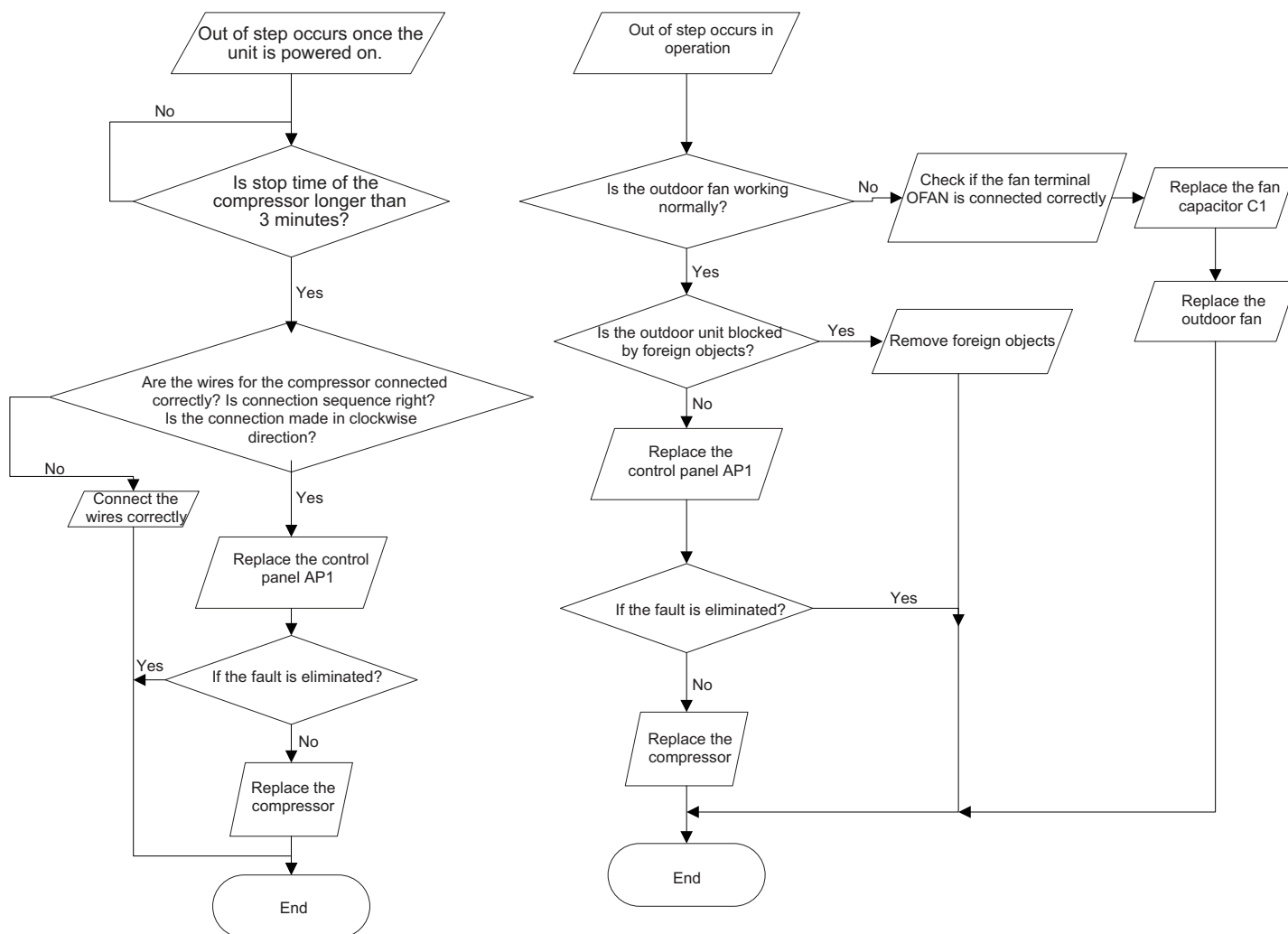

(7) Power factor correct or (PFC) fault (a fault of outdoor unit) (AP1 hereinafter refers to the control board of the outdoor unit)

Mainly detect:

- Check if the reactor (L) of the outdoor unit and the PFC capacitor are broken

Fault diagnosis process:

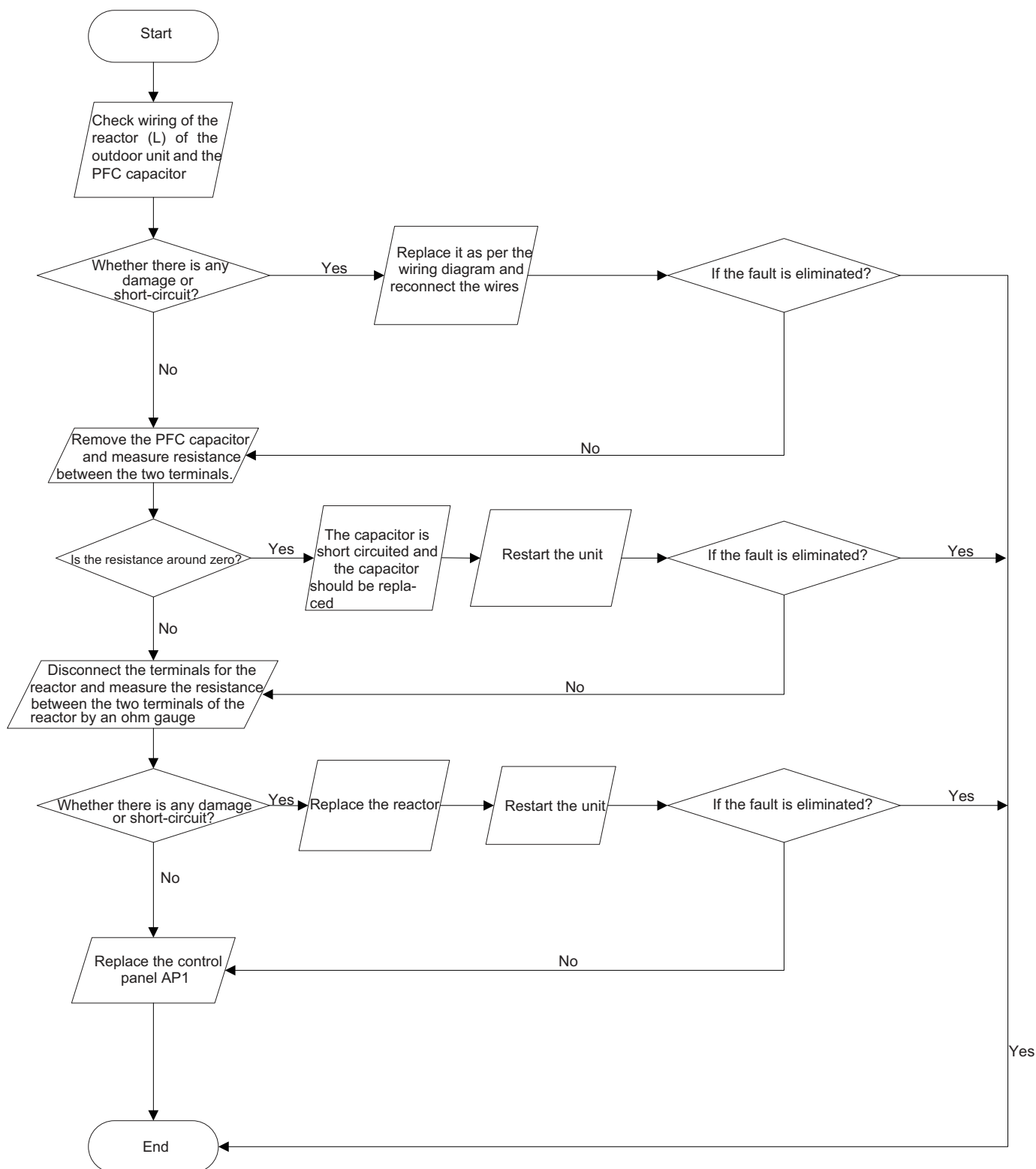

(8) Communication malfunction: (following AP1 for outdoor unit control board)

Mainly detect:

- Is there any damage for the indoor unit mainboard communication circuit? Is communication circuit damaged?
- Detect the indoor and outdoor units connection wire and indoor and outdoor units inside wiring is connect well or not, if is there any damage?

Fault diagnosis process:

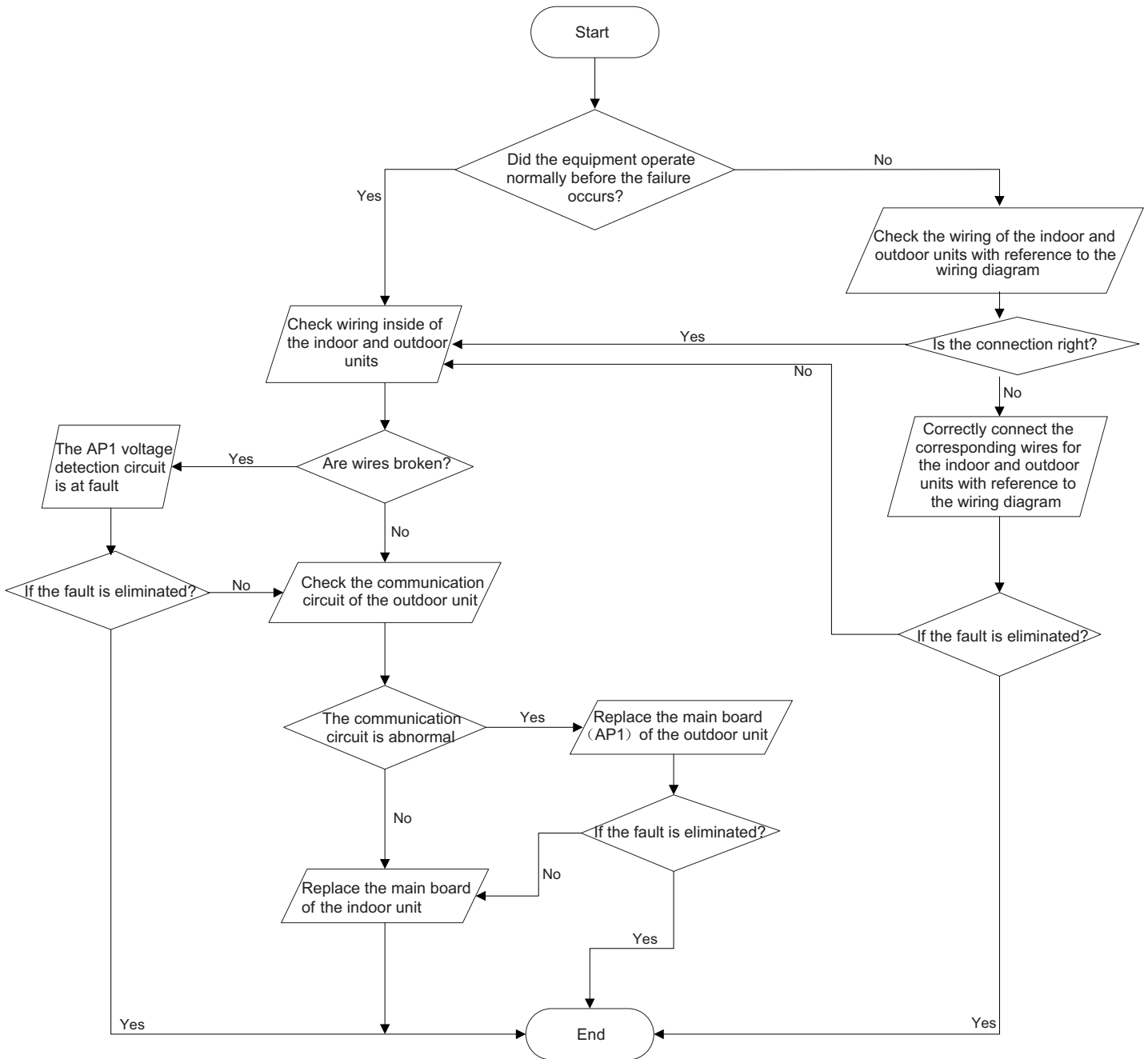

(9) Malfunction of Overcurrent Protection

Main detection points:

- Is the supply voltage unstable with big fluctuation?
- Is the supply voltage too low with overload?
- Hardware trouble?

Malfunction diagnosis process:

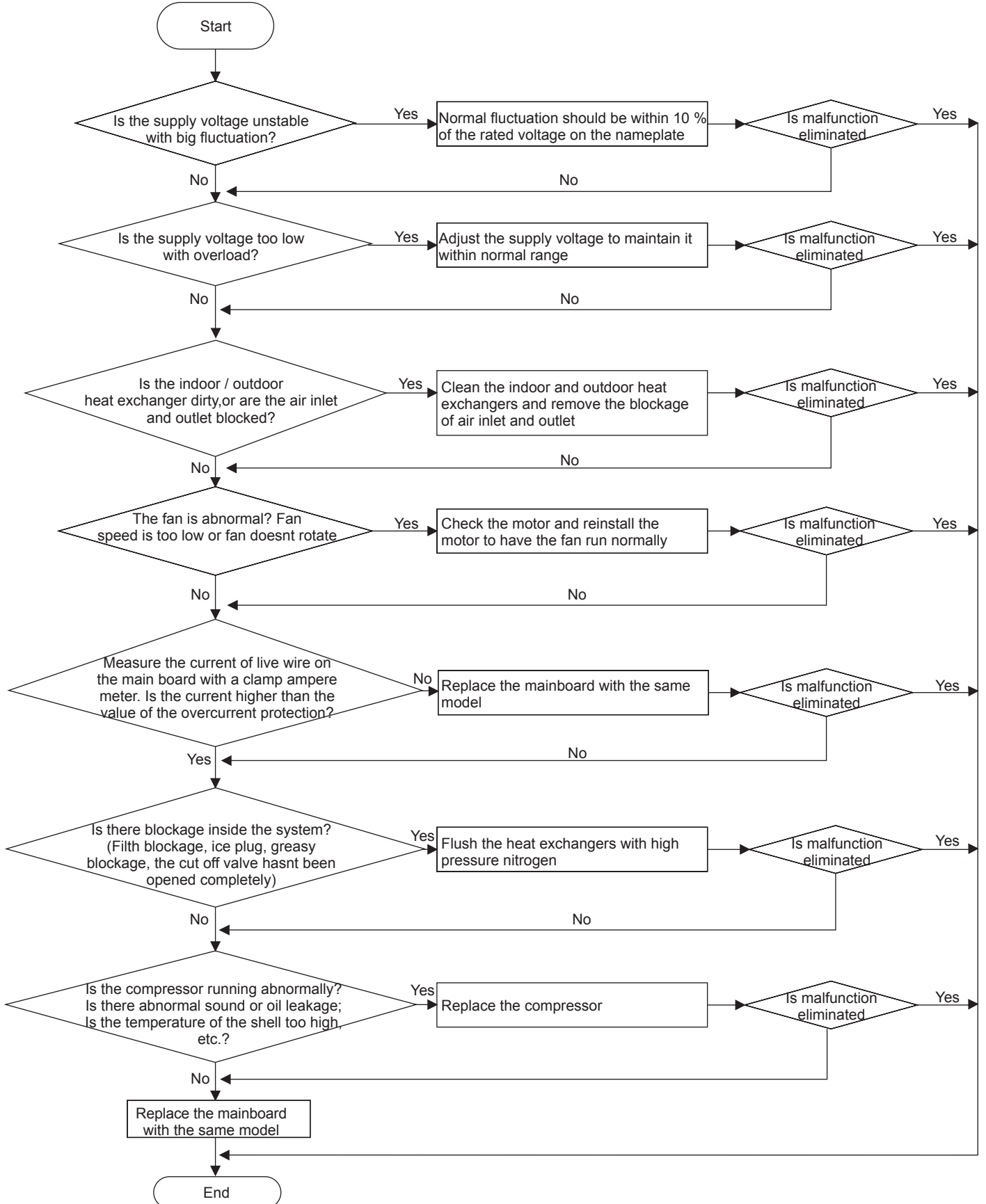

9.3 Troubleshooting for Normal Malfunction

1. Air Conditioner Cant be Started Up

Possible Causes	Discriminating Method (Air conditioner Status)	Troubleshooting
No power supply, or poor connection for power plug	After energization, operation indicator isnt bright and the buzzer cant give out sound	Confirm whether its due to power failure. If yes, wait for power recovery. If not, check power supply circuit and make sure the power plug is connected well.
Wrong wire connection between indoor unit and outdoor unit, or poor connection for wiring terminals	Under normal power supply circumstances, operation indicator isnt bright after energization	Check the circuit according to circuit diagram and connect wires correctly. Make sure all wiring terminals are connected firmly
Electric leakage for air conditioner	After energization, room circuit breaker trips off at once	Make sure the air conditioner is grounded reliably Make sure wires of air conditioner is connected correctly Check the wiring inside air conditioner. Check whether the insulation layer of power cord is damaged; if yes, place the power cord.
Model selection for air switch is improper	After energization, air switch trips off	Select proper air switch
Malfunction of remote controller	After energization, operation indicator is bright, while no display on remote controller or buttons have no action.	Replace batteries for remote controller Repair or replace remote controller

2. Poor Cooling (Heating) for Air Conditioner

Possible Causes	Discriminating Method (Air conditioner Status)	Troubleshooting
Set temperature is improper	Observe the set temperature on remote controller	Adjust the set temperature
Rotation speed of the IDU fan motor is set too low	Small wind blow	Set the fan speed at high or medium
Filter of indoor unit is blocked	Check the filter to see its blocked	Clean the filter
Installation position for indoor unit and outdoor unit is improper	Check whether the installation postion is proper according to installation requirement for air conditioner	Adjust the installation position, and install the rainproof and sunproof for outdoor unit
Refrigerant is leaking	Discharged air temperature during cooling is higher than normal discharged wind temperature; Discharged air temperature during heating is lower than normal discharged wind temperature; Units pressure is much lower than regulated range	Find out the leakage causes and deal with it. Add refrigerant.
Malfunction of 4-way valve	Blow cold wind during heating	Replace the 4-way valve
Malfunction of capillary	Discharged air temperature during cooling is higher than normal discharged wind temperature; Discharged air temperature during heating is lower than normal discharged wind temperature; Unitt pressure is much lower than regulated range. If refrigerant isnt leaking, part of capillary is blocked	Replace the capillary
Flow volume of valve is insufficient	The pressure of valves is much lower than that stated in the specification	Open the valve completely
Malfunction of horizontal louver	Horizontal louver cant swing	Refer to point 3 of maintenance method for details
Malfunction of the IDU fan motor	The IDU fan motor cant operate	Refer to troubleshooting for H6 for maintenance method in details
Malfunction of the ODU fan motor	The ODU fan motor cant operate	Refer to point 4 of maintenance method for details
Malfunction of compressor	Compressor cant operate	Refer to point 5 of maintenance method for details

3. Horizontal Louver Cant Swing

Possible Causes	Discriminating Method (Air conditioner Status)	Troubleshooting
Wrong wire connection, or poor connection	Check the wiring status according to circuit diagram	Connect wires according to wiring diagram to make sure all wiring terminals are connected firmly
Stepping motor is damaged	Stepping motor cant operate	Repair or replace stepping motor
Main board is damaged	Others are all normal, while horizontal louver cant operate	Replace the main board with the same model

4. ODU Fan Motor Cant Operate

Possible causes	Discriminating method (air conditioner status)	Troubleshooting
Wrong wire connection, or poor connection	Check the wiring status according to circuit diagram	Connect wires according to wiring diagram to make sure all wiring terminals are connected firmly
Capacity of the ODU fan motor is damaged	Measure the capacity of fan capacitor with an universal meter and find that the capacity is out of the deviation range indicated on the nameplate of fan capacitor.	Replace the capacity of fan
Power voltage is a little low or high	Use universal meter to measure the power supply voltage. The voltage is a little high or low	Suggest to equip with voltage regulator
Motor of outdoor unit is damaged	When unit is on, cooling/heating performance is bad and ODU compressor generates a lot of noise and heat.	Change compressor oil and refrigerant. If no better, replace the compressor with a new one

5. Compressor Cant Operate

Possible causes	Discriminating method (air conditioner status)	Troubleshooting
Wrong wire connection, or poor connection	Check the wiring status according to circuit diagram	Connect wires according to wiring diagram to make sure all wiring terminals are connected firmly
Capacity of compressor is damaged	Measure the capacity of fan capacitor with an universal meter and find that the capacity is out of the deviation range indicated on the nameplate of fan capacitor.	Replace the compressor capacitor
Power voltage is a little low or high	Use universal meter to measure the power supply voltage. The voltage is a little high or low	Suggest to equip with voltage regulator
Coil of compressor is burnt out	Use universal meter to measure the resistance between compressor terminals and its 0	Repair or replace compressor
Cylinder of compressor is blocked	Compressor cant operate	Repair or replace compressor

6. Air Conditioner is Leaking

Possible causes	Discriminating method (air conditioner status)	Troubleshooting
Drain pipe is blocked	Water leaking from indoor unit	Eliminate the foreign objects inside the drain pipe
Drain pipe is broken	Water leaking from drain pipe	Replace drain pipe
Wrapping is not tight	Water leaking from the pipe connection place of indoor unit	Wrap it again and bundle it tightly

7. Abnormal Sound and Vibration

Possible causes	Discriminating method (air conditioner status)	Troubleshooting
When turn on or turn off the unit, the panel and other parts will expand and theres abnormal sound	Theres the sound of "PAPA"	Normal phenomenon. Abnormal sound will disappear after a few minutes.
When turn on or turn off the unit, theres abnormal sound due to flow of refrigerant inside air conditioner	Water-running sound can be heard	Normal phenomenon. Abnormal sound will disappear after a few minutes.
Foreign objects inside the indoor unit or therere parts touching together inside the indoor unit	Theres abnormal sound fro indoor unit	Remove foreign objects. Adjust all parts position of indoor unit, tighten screws and stick damping plaster between connected parts
Foreign objects inside the outdoor unit or therere parts touching together inside the outdoor unit	Theres abnormal sound fro outdoor unit	Remove foreign objects. Adjust all parts position of outdoor unit, tighten screws and stick damping plaster between connected parts
Short circuit inside the magnetic coil	During heating, the way valve has abnormal electromagnetic sound	Replace magnetic coil
Abnormal shake of compressor	Outdoor unit gives out abnormal sound	Adjust the support foot mat of compressor, tighten the bolts
Abnormal sound inside the compressor	Abnormal sound inside the compressor	If add too much refrigerant during maintenance, please reduce refrigerant properly. Replace compressor for other circumstances.

NO.	Description	Part Code			Qty
		GWH09QB-K6DNA1C/I	GWH09QB-K6DNB6C/I	GWH12QC-K6DNA1C/I	
	Product Code	CB419N11900	CB435N07500	CB419N12300	
1	Front Panel	20022479S	20000300050T	20022475S	1
2	Display Board	30565231	30565281	30565231	1
3	Front Case Assy	20022495	00000200040	20022489	1
4	Helicoid Tongue	26112508	26112508	26112436	1
5	Left Axile Bush	10512037	10512037	10512037	1
6	Rear Case assy	20162010	20162010	00000100093	1
7	Drainage Hose	0523001408	0523001408	05230014	1
8	Ring of Bearing	26152022	26152022	26152022	1
9	Evaporator Support	24212180	24212180	24212179	1
10	Cold Plasma Generator	1114001603	1114001603	1114001603	1
11	Evaporator Assy	0100200004406	0100200004406	01100100245	1
12	Wall Mounting Frame	01252043	01252043	01252484	1
13	Cross Flow Fan	10352059	10352059	10352056	1
14	Fan Motor	150120874	150120874	15012146	1
15	Connecting pipe clamp	2611216401	2611216401	2611216401	1
16	Rubber Plug (Water Tray)	76712012	76712012	76712012	1
17	Stepping Motor	1521212901	1521212901	1521210701	1
18	Crank	73012005	73012005	73012005	1
19	Electric Box Assy	100002001192	100002003076	100002001118	1
20	Axile Bush	10542036	10542036	10542036	1
21	Terminal Board	42011233	42011233	42011233	1
22	Jumper	4202021901	4202021904	4202021905	1
23	Main Board	300002000288	300002000288	300002000291	1
24	Electric Box Cover Sub-Assy	0140206501	0140206501	0140206501	1
25	Shield Cover of Electric Box Cover	01592150	01592150	01592150	1
26	Electric Box Cover	20112207	20112207	2011220701	1
27	Power Cord	/	/	/	/
28	Connecting Cable	4002052317	4002052317	4002052317	0
29	Remote Controller	30510474	305001000087	30510474	1
30	Capacitor CBB61	33010079	33010747	3301074712	1
31	Detecting Plate	30110144	30110154	30110144	1

Above data is subject to change without notice.

NO.	Description	Part Code			Qty
		GWH09QB-K6DNA3C/I	GWH12QC-K6DNA3C/I	GWH12QC-K6DNB6C/I	
	Product Code	CB424N04900	CB424N05200	CB435N07300	
1	Front Panel	2002269701S	2002269301S	20000300049T	1
2	Display Board	30565263	30565263	30565281	1
3	Front Case Assy	00000200119	00000200109	00000200045	1
4	Helicoid Tongue	26112508	26112436	26112436	1
5	Left Axile Bush	10512037	10512037	10512037	1
6	Rear Case assy	20162010	00000100093	00000100093	1
7	Drainage Hose	0523001408	05230014	05230014	1
8	Ring of Bearing	26152022	26152022	26152022	1
9	Evaporator Support	24212180	24212179	24212179	1
10	Cold Plasma Generator	1114001603	1114001603	1114001603	1
11	Evaporator Assy	0100200004406	01100100245	01100100245	1
12	Wall Mounting Frame	01252043	01252484	01252484	1
13	Cross Flow Fan	10352059	10352056	10352056	1
14	Fan Motor	150120874	15012146	15012146	1
15	Connecting pipe clamp	2611216401	2611216401	2611216401	1
16	Rubber Plug (Water Tray)	76712012	76712012	76712012	1
17	Stepping Motor	1521212901	1521210710	1521210710	1
18	Crank	73012005	73012005	73012005	1
19	Electric Box Assy	100002002275	100002002274	100002002841	1
20	Axile Bush	10542036	10542036	10542036	1
21	Terminal Board	42011233	42011233	42011233	1
22	Jumper	4202021905	4202021905	4202021914	1
23	Main Board	300002000288	300002000291	300002000291	1
24	Electric Box Cover Sub-Assy	0140206501	0140206501	0140206501	1
25	Shield Cover of Electric Box Cover	01592150	01592150	01592150	1
26	Electric Box Cover	20112207	2011220701	2011220701	1
27	Power Cord	/	/	/	/
28	Connecting Cable	4002052317	4002052317	4002052317	0
29	Remote Controller	30510474	30510474	305001000087	1
30	Capacitor CBB61	33010747	3301074712	3301074712	1
31	Detecting Plate	30110154	30110144	30110144	1

Above data is subject to change without notice.

NO.	Description	Part Code			Qty
		GWH09QB-K6DND4C/I	GWH09QB-K6DNE6C/I	GWH09QB-K6DNB8I/I	
	Product Code	CB464N00300	CB465N00600	CB438N07400	
1	Front Panel	200003000075T	200003000044S	200003000073T	1
2	Display Board	300001000081	300001000035	30565260	1
3	Front Case Assy	00000200040	00000200040	00000200040	1
4	Helicoid Tongue	26112508	26112508	26112508	1
5	Left Axile Bush	10512037	10512037	10512037	1
6	Rear Case assy	20162010	20162010	20162010	1
7	Drainage Hose	0523001408	0523001408	0523001408	1
8	Ring of Bearing	26152022	26152022	26152022	1
9	Evaporator Support	24212180	24212180	24212180	1
10	Cold Plasma Generator	1114001603	1114001603	1114001603	1
11	Evaporator Assy	0100200004406	0100200004406	0100200004406	1
12	Wall Mounting Frame	01252043	01252043	01252043	1
13	Cross Flow Fan	10352059	10352059	10352059	1
14	Fan Motor	150120874	150120874	150120874	1
15	Connecting pipe clamp	2611216401	2611216401	2611216401	1
16	Rubber Plug (Water Tray)	76712012	76712012	76712012	1
17	Stepping Motor	1521212901	1521212901	1521212901	1
18	Crank	73012005	73012005	73012005	1
19	Electric Box Assy	100002002491	100002002490	100002003790	1
20	Axile Bush	10542036	10542036	10542036	1
21	Terminal Board	42011233	42011233	42011233	1
22	Jumper	4202021904	4202021904	4202021904	1
23	Main Board	300002000288	300002000288	300002000288	1
24	Electric Box Cover Sub-Assy	0140206501	0140206501	0140206501	1
25	Shield Cover of Electric Box Cover	01592150	01592150	01592150	1
26	Electric Box Cover	20112207	20112207	20112207	1
27	Power Cord	/	/	/	/
28	Connecting Cable	4002052317	4002052317	4002052317	0
29	Remote Controller	30510474	30510474	305001000087	1
30	Capacitor CBB61	33010747	33010747	33010747	1
31	Detecting Plate	30110154	30110154	30110154	1

Above data is subject to change without notice.

NO.	Description	Part Code			Qty
		GWH12QC-K6DNE6C/I	GWH12QC-K6DND4C/I	GWH12QC-K6DND6C/I	
	Product Code	CB465N00500	CB464N00200	CB460N03500	
1	Front Panel	20000300068S	20000300069T	200003000029S	1
2	Display Board	300001000035	300001000081	300001000041	1
3	Front Case Assy	00000200045	00000200045	00000200045	1
4	Helicoid Tongue	26112436	26112436	26112436	1
5	Left Axile Bush	10512037	10512037	10512037	1
6	Rear Case assy	00000100093	00000100093	00000100093	1
7	Drainage Hose	05230014	05230014	05230014	1
8	Ring of Bearing	26152022	26152022	26152022	1
9	Evaporator Support	24212179	24212179	24212179	1
10	Cold Plasma Generator	1114001603	1114001603	1114001603	1
11	Evaporator Assy	01100100245	01100100245	01100100245	1
12	Wall Mounting Frame	01252484	01252484	01252484	1
13	Cross Flow Fan	10352056	10352056	10352056	1
14	Fan Motor	15012146	15012146	15012146	1
15	Connecting pipe clamp	2611216401	2611216401	2611216401	1
16	Rubber Plug (Water Tray)	76712012	76712012	76712012	1
17	Stepping Motor	1521210710	1521210710	1521210710	1
18	Crank	73012005	73012005	73012005	1
19	Electric Box Assy	100002002495	100002002501	100002003201	1
20	Axile Bush	10542036	10542036	10542036	1
21	Terminal Board	42011233	42011233	42011233	1
22	Jumper	4202021914	4202021914	4202021914	1
23	Main Board	300002000291	300002000291	300002000291	1
24	Electric Box Cover Sub-Assy	0140206501	0140206501	0140206501	1
25	Shield Cover of Electric Box Cover	01592150	01592150	01592150	1
26	Electric Box Cover	2011220701	2011220701	2011220701	1
27	Power Cord	/	/	/	/
28	Connecting Cable	4002052317	4002052317	4002052317	0
29	Remote Controller	30510474	30510474	30510474	1
30	Capacitor CBB61	3301074712	3301074712	3301074712	1
31	Detecting Plate	30110144	30110144	30110144	1

Above data is subject to change without notice.

NO.	Description	Part Code			Qty
		GWH09QB-K6DND6C/I	GWH09QB-K6DNC2C/I	GWH09QB-K6DNB4I/I	
	Product Code	CB460N03000	CB439N09200	CB434N11500	
1	Front Panel	20000300068S	200003000044	20000300026	1
2	Display Board	300001000041	300001000035	30565260	1
3	Front Case Assy	00000200040	00000200040	00000200040	1
4	Helicoid Tongue	26112508	26112508	26112508	1
5	Left Axile Bush	10512037	10512037	10512037	1
6	Rear Case assy	20162010	20162010	20162010	1
7	Drainage Hose	0523001408	0523001408	0523001408	1
8	Ring of Bearing	26152022	26152022	26152022	1
9	Evaporator Support	24212180	24212180	24212180	1
10	Cold Plasma Generator	1114001603	1114001603	1114001603	1
11	Evaporator Assy	0100200004406	0100200004406	0100200004406	1
12	Wall Mounting Frame	01252043	01252043	01252043	1
13	Cross Flow Fan	10352059	10352059	10352059	1
14	Fan Motor	150120874	150120874	150120874	1
15	Connecting pipe clamp	2611216401	2611216401	2611216401	1
16	Rubber Plug (Water Tray)	76712012	76712012	76712012	1
17	Stepping Motor	1521212901	1521212901	1521212901	1
18	Crank	73012005	73012005	73012005	1
19	Electric Box Assy	100002002891	100002002490	100002003790	1
20	Axile Bush	10542036	10542036	10542036	1
21	Terminal Board	42011233	42011233	42011233	1
22	Jumper	4202021904	4202021904	4202021904	1
23	Main Board	300002000288	300002000288	300002000288	1
24	Electric Box Cover Sub-Assy	0140206501	0140206501	0140206501	1
25	Shield Cover of Electric Box Cover	01592150	01592150	01592150	1
26	Electric Box Cover	20112207	20112207	20112207	1
27	Power Cord	/	/	/	/
28	Connecting Cable	4002052317	4002052317	4002052317	0
29	Remote Controller	305001000087	30510474	305001000087	1
30	Capacitor CBB61	33010747	33010747	33010747	1
31	Detecting Plate	30110154	30110154	30110154	1

Above data is subject to change without notice.

NO.	Description	Part Code			Qty
		GWH09QB-K6DNC8C/I	GWH12QC-K6DNC8C/I	GWH12QC-K6DNB4C/I	
	Product Code	CB456N03500	CB456N03200	CB434N12000	
1	Front Panel	20000300155T	20000300154T	20000300027T	1
2	Display Board	30565281	30565281	30565260	1
3	Front Case Assy	00000200040	00000200045	00000200045	1
4	Helicoid Tongue	26112508	26112436	26112436	1
5	Left Axile Bush	10512037	10512037	10512037	1
6	Rear Case assy	20162010	00000100093	00000100093	1
7	Drainage Hose	0523001408	05230014	05230014	1
8	Ring of Bearing	26152022	26152022	26152022	1
9	Evaporator Support	24212180	24212179	24212179	1
10	Cold Plasma Generator	1114001603	1114001603	1114001603	1
11	Evaporator Assy	0100200004406	01100100245	0100297601	1
12	Wall Mounting Frame	01252043	01252484	01252484	1
13	Cross Flow Fan	10352059	10352056	10352056	1
14	Fan Motor	150120874	15012146	15012146	1
15	Connecting pipe clamp	2611216401	2611216401	2611216401	1
16	Rubber Plug (Water Tray)	76712012	76712012	76712012	1
17	Stepping Motor	1521212901	1521210710	1521210710	1
18	Crank	73012005	73012005	73012005	1
19	Electric Box Assy	100002003076	100002002841	100002060353	1
20	Axile Bush	10542036	10542036	10542036	1
21	Terminal Board	42011233	42011233	42011233	1
22	Jumper	4202021904	4202021914	4202021914	1
23	Main Board	300002000288	300002000291	300002000291	1
24	Electric Box Cover Sub-Assy	0140206501	0140206501	0140206501	1
25	Shield Cover of Electric Box Cover	01592150	01592150	01592150	1
26	Electric Box Cover	20112207	2011220701	2011220701	1
27	Power Cord	/	/	/	/
28	Connecting Cable	4002052317	4002052317	4002052317	0
29	Remote Controller	30510474	30510474	305001000087	1
30	Capacitor CBB61	33010747	3301074712	3301074712	1
31	Detecting Plate	30110154	30110144	30110144	1

Above data is subject to change without notice.

NO.	Description	Part Code			Qty
		GWH09QB-K6DND4C/I	GWH09QB-K6DNE6C/I	GWH12QC-K6DNB2C/I	
		Product Code			
1	Front Panel	200003000075T	200003000044S	20000300018	1
2	Display Board	300001000081	300001000035	30565260	1
3	Front Case Assy	00000200040	00000200040	00000200045	1
4	Helicoid Tongue	26112508	26112508	26112436	1
5	Left Axile Bush	10512037	10512037	10512037	1
6	Rear Case assy	20162010	20162010	00000100093	1
7	Drainage Hose	0523001408	0523001408	05230014	1
8	Ring of Bearing	26152022	26152022	26152022	1
9	Evaporator Support	24212180	24212180	24212179	1
10	Cold Plasma Generator	/	/	1114001603	1
11	Evaporator Assy	0100200004407	0100200004407	0100297601	1
12	Wall Mounting Frame	01252043	01252043	01252484	1
13	Cross Flow Fan	10352059	10352059	10352056	1
14	Fan Motor	150120874	150120874	15012146	1
15	Connecting pipe clamp	2611216401	2611216401	2611216401	1
16	Rubber Plug (Water Tray)	76712012	76712012	76712012	1
17	Stepping Motor	1521212901	1521212901	1521210710	1
18	Crank	73012005	73012005	73012005	1
19	Electric Box Assy	100002003286	100002003284	100002060353	1
20	Axile Bush	10542036	10542036	10542036	1
21	Terminal Board	42011233	42011233	42011233	1
22	Jumper	4202021904	4202021904	4202021914	1
23	Main Board	300002000286	300002000286	300002000291	1
24	Electric Box Cover Sub-Assy	0140206501	0140206501	0140206501	1
25	Shield Cover of Electric Box Cover	01592150	01592150	01592150	1
26	Electric Box Cover	20112207	20112207	2011220701	1
27	Power Cord	/	/	/	/
28	Connecting Cable	4002052317	4002052317	4002052317	0
29	Remote Controller	30510474	30510474	305001000087	1
30	Capacitor CBB61	33010747	33010747	3301074712	1
31	Detecting Plate	30110154	30110154	30110144	1

Above data is subject to change without notice.

NO.	Description	Part Code			Qty
		GWH12QC-K6DNE4C/I	GWH09QB-K6DNB2C/I	GWH09QB-K6DNC4C/I	
	Product Code	CB470N02100	CB432N12500	CB444N09200	
1	Front Panel	200003000067T	20000300019S	20000300105S	1
2	Display Board	300001000081	30565260	30565260	1
3	Front Case Assy	00000200045	00000200040	00000200040	1
4	Helicoid Tongue	26112436	26112508	26112508	1
5	Left Axile Bush	10512037	10512037	10512037	1
6	Rear Case assy	00000100093	20162010	20162010	1
7	Drainage Hose	05230014	0523001408	0523001408	1
8	Ring of Bearing	26152022	26152022	26152022	1
9	Evaporator Support	24212179	24212180	24212180	1
10	Cold Plasma Generator	1114001603	1114001603	1114001603	1
11	Evaporator Assy	0100297601	010020004406	010020004406	1
12	Wall Mounting Frame	01252484	01252043	01252043	1
13	Cross Flow Fan	10352056	10352059	10352059	1
14	Fan Motor	15012146	150120874	150120874	1
15	Connecting pipe clamp	2611216401	2611216401	2611216401	1
16	Rubber Plug (Water Tray)	76712012	76712012	76712012	1
17	Stepping Motor	1521210710	1521212901	1521212901	1
18	Crank	73012005	73012005	73012005	1
19	Electric Box Assy	100002002501	100002003790	100002003790	1
20	Axile Bush	10542036	10542036	10542036	1
21	Terminal Board	42011233	42011233	42011233	1
22	Jumper	4202021914	4202021904	4202021904	1
23	Main Board	300002000291	300002000288	300002000288	1
24	Electric Box Cover Sub-Assy	0140206501	0140206501	0140206501	1
25	Shield Cover of Electric Box Cover	01592150	01592150	01592150	1
26	Electric Box Cover	2011220701	20112207	20112207	1
27	Power Cord	/	/	/	/
28	Connecting Cable	4002052317	4002052317	4002052317	0
29	Remote Controller	30510474	30510474	305001000087	1
30	Capacitor CBB61	3301074712	33010747	33010747	1
31	Detecting Plate	30110144	30110154	30110154	1

Above data is subject to change without notice.

NO.	Description	Part Code			Qty
		GWH09QB-K6DNE4C/I	GWH09QB-K6DNB4C/I	GWH09QB-K6DND6I/I	
	Product Code	CB470N02000	CB434N11300	CB460N05600	
1	Front Panel	200003000065S	20000300026T	200003000028S	1
2	Display Board	300001000081	30565260	300001000041	1
3	Front Case Assy	00000200040	00000200040	00000200040	1
4	Helicoid Tongue	26112508	26112508	26112508	1
5	Left Axile Bush	10512037	10512037	10512037	1
6	Rear Case assy	20162010	20162010	20162010	1
7	Drainage Hose	0523001408	0523001408	0523001408	1
8	Ring of Bearing	26152022	26152022	26152022	1
9	Evaporator Support	24212180	24212180	24212180	1
10	Cold Plasma Generator	1114001603	1114001603	1114001603	1
11	Evaporator Assy	0100200004406	0100200004406	0100200004406	1
12	Wall Mounting Frame	01252043	01252043	01252043	1
13	Cross Flow Fan	10352059	10352059	10352059	1
14	Fan Motor	150120874	150120874	150120874	1
15	Connecting pipe clamp	2611216401	2611216401	2611216401	1
16	Rubber Plug (Water Tray)	76712012	76712012	76712012	1
17	Stepping Motor	1521212901	1521212901	1521212901	1
18	Crank	73012005	73012005	73012005	1
19	Electric Box Assy	100002002491	100002003790	100002002891	1
20	Axile Bush	10542036	10542036	10542036	1
21	Terminal Board	42011233	42011233	42011233	1
22	Jumper	4202021904	4202021904	4202021904	1
23	Main Board	300002000288	300002000288	300002000288	1
24	Electric Box Cover Sub-Assy	0140206501	0140206501	0140206501	1
25	Shield Cover of Electric Box Cover	01592150	01592150	01592150	1
26	Electric Box Cover	20112207	20112207	20112207	1
27	Power Cord	/	/	/	/
28	Connecting Cable	4002052317	4002052317	4002052317	0
29	Remote Controller	30510474	30510474	305001000087	1
30	Capacitor CBB61	33010747	33010747	33010747	1
31	Detecting Plate	30110154	30110154	30110154	1

Above data is subject to change without notice.

NO.	Description	Part Code			Qty
		GWH09QB-K6DNC4I/I	GWH09QB-K6DNE4I/I	GWH09QB-K6DNA5I/I	
	Product Code	CB444N07400	CB470N02200	CB425N11700	
1	Front Panel	20000300105S	200003000065T	00000300036	1
2	Display Board	30565260	300001000081	30565260	1
3	Front Case Assy	00000200040	00000200040	2002249501	1
4	Helicoid Tongue	26112508	26112508	26112508	1
5	Left Axile Bush	10512037	10512037	10512037	1
6	Rear Case assy	20162010	20162010	20162010	1
7	Drainage Hose	0523001408	0523001408	0523001408	1
8	Ring of Bearing	26152022	26152022	26152022	1
9	Evaporator Support	24212180	24212180	24212180	1
10	Cold Plasma Generator	1114001603	1114001603	1114001603	1
11	Evaporator Assy	0100200004406	0100200004406	0100200004406	1
12	Wall Mounting Frame	01252043	01252043	01252043	1
13	Cross Flow Fan	10352059	10352059	10352059	1
14	Fan Motor	150120874	150120874	150120874	1
15	Connecting pipe clamp	2611216401	2611216401	2611216401	1
16	Rubber Plug (Water Tray)	76712012	76712012	76712012	1
17	Stepping Motor	1521212901	1521212901	1521212901	1
18	Crank	73012005	73012005	73012005	1
19	Electric Box Assy	100002003790	100002002491	100002061596	1
20	Axile Bush	10542036	10542036	10542036	1
21	Terminal Board	42011233	42011233	42011233	1
22	Jumper	4202021904	4202021904	4202021901	1
23	Main Board	300002000288	300002000288	300002000288	1
24	Electric Box Cover Sub-Assy	0140206501	0140206501	0140206501	1
25	Shield Cover of Electric Box Cover	01592150	01592150	01592150	1
26	Electric Box Cover	20112207	20112207	20112207	1
27	Power Cord	/	/	/	/
28	Connecting Cable	4002052317	4002052317	4002052317	0
29	Remote Controller	305001000087	305001000087	305001000087	1
30	Capacitor CBB61	33010747	33010747	33010747	1
31	Detecting Plate	30110154	30110154	30110154	1

Above data is subject to change without notice.

NO.	Description	Part Code			Qty
		GWH12QB-K6DNC4I/I	GWH12QB-K6DNE4I/I	GWH12QC-K6DNC4C/I	
	Product Code	CB444N07500	CB470N02300	CB444N09300	
1	Front Panel	20000300105S	200003000065T	20000300098S	1
2	Display Board	30565260	300001000081	30565260	1
3	Front Case Assy	00000200040	00000200040	00000200045	1
4	Helicoid Tongue	26112508	26112508	26112436	1
5	Left Axile Bush	10512037	10512037	10512037	1
6	Rear Case assy	20162010	20162010	00000100093	1
7	Drainage Hose	0523001408	0523001408	05230014	1
8	Ring of Bearing	26152022	26152022	26152022	1
9	Evaporator Support	24212180	24212180	24212179	1
10	Cold Plasma Generator	1114001603	1114001603	1114001603	1
11	Evaporator Assy	0110010009507	0110010009507	0100297601	1
12	Wall Mounting Frame	01252043	01252043	01252484	1
13	Cross Flow Fan	10352059	10352059	10352056	1
14	Fan Motor	150120874	150120874	15012146	1
15	Connecting pipe clamp	2611216401	2611216401	2611216401	1
16	Rubber Plug (Water Tray)	76712012	76712012	76712012	1
17	Stepping Motor	1521212901	1521212901	1521210710	1
18	Crank	73012005	73012005	73012005	1
19	Electric Box Assy	100002002895	100002002712	100002060353	1
20	Axile Bush	10542036	10542036	10542036	1
21	Terminal Board	42011233	42011233	42011233	1
22	Jumper	4202021911	4202021911	4202021914	1
23	Main Board	30145096	30145096	300002000291	1
24	Electric Box Cover Sub-Assy	0140206501	0140206501	0140206501	1
25	Shield Cover of Electric Box Cover	01592150	01592150	01592150	1
26	Electric Box Cover	20112207	20112207	2011220701	1
27	Power Cord	/	/	/	/
28	Connecting Cable	4002052317	4002052317	4002052317	0
29	Remote Controller	305001000087	305001000087	305001000087	1
30	Capacitor CBB61	33010747	33010747	33010747	1
31	Detecting Plate	30110154	30110154	30110144	1

Above data is subject to change without notice.

NO.	Description	Part Code			Qty
		GWH09QB-K6DND6C/I	GWH09QB-K6DNA1I/I	GWH12QC-K6DNB6C/I	
	Product Code	CB460N03002	CB419N15100	CB435N07300	
1	Front Panel	200003000028S	20022479S	20000300049T	1
2	Display Board	300001000041	30565263	30565281	1
3	Front Case Assy	00000200040	00000200128	00000200045	1
4	Helicoid Tongue	26112508	26112508	26112436	1
5	Left Axile Bush	10512037	10512037	10512037	1
6	Rear Case assy	20162010	20162010	00000100093	1
7	Drainage Hose	0523001408	0523001408	05230014	1
8	Ring of Bearing	26152022	26152022	26152022	1
9	Evaporator Support	24212180	24212180	24212179	1
10	Cold Plasma Generator	/	1114001603	1114001603	1
11	Evaporator Assy	0100200004402	0100200004406	01100100245	1
12	Wall Mounting Frame	01252043	01252043	01252484	1
13	Cross Flow Fan	10352059	10352059	10352056	1
14	Fan Motor	150120874	150120874	15012146	1
15	Connecting pipe clamp	2611216401	2611216401	2611216401	1
16	Rubber Plug (Water Tray)	76712012	76712012	76712012	1
17	Stepping Motor	1521212901	1521212901	1521210710	1
18	Crank	73012005	73012005	73012005	1
19	Electric Box Assy	100002060403	100002002275	100002002841	1
20	Axile Bush	10542036	10542036	10542036	1
21	Terminal Board	42011233	42011233	42011233	1
22	Jumper	4202021904	4202021901	4202021914	1
23	Main Board	300002000286	300002000288	300002000291	1
24	Electric Box Cover Sub-Assy	0140206501	0140206501	0140206501	1
25	Shield Cover of Electric Box Cover	01592150	01592150	01592150	1
26	Electric Box Cover	20112207	20112207	2011220701	1
27	Power Cord	/	/	/	/
28	Connecting Cable	4002052317	4002052317	4002052317	0
29	Remote Controller	305001000087	305001000087	30510474	1
30	Capacitor CBB61	33010747	33010747	3301074712	1
31	Detecting Plate	30110154	30110154	30110144	1

Above data is subject to change without notice.

NO.	Description	Part Code			Qty
		GWH09QB-K6DNB2C/I	GWH12QC-K6DNB2C/I	GWH09QB-K6DNA3I/I	
	Product Code	CB432N12501	CB432N14801	CB424N06800	
1	Front Panel	20000300019S	20000300018	2002269701S	1
2	Display Board	30565260	30565260	300001060081	1
3	Front Case Assy	00000200040	00000200045	2002278101	1
4	Helicoid Tongue	26112508	26112436	2611250801	1
5	Left Axile Bush	10512037	10512037	1051203702	1
6	Rear Case assy	20162010	00000100093	2016201001	1
7	Drainage Hose	0523001408	05230014	0523001408	1
8	Ring of Bearing	26152022	26152022	26152022	1
9	Evaporator Support	24212180	24212179	24212180	1
10	Cold Plasma Generator	/	/	1114001603	1
11	Evaporator Assy	0100200004410	0100297602	0100200004406	1
12	Wall Mounting Frame	01252043	01252484	01252043	1
13	Cross Flow Fan	10352059	10352056	10352059	1
14	Fan Motor	150120874	15012146	150120874	1
15	Connecting pipe clamp	2611216401	2611216401	2611216403	1
16	Rubber Plug (Water Tray)	76712012	76712012	76712012	1
17	Stepping Motor	1521212901	1521210710	1521212901	1
18	Crank	73012005	73012005	7301200502	1
19	Electric Box Assy	100002061266	100002061267	100002002275	1
20	Axile Bush	10542036	10542036	1054203601	1
21	Terminal Board	42011233	42011233	42011233	1
22	Jumper	4202021904	4202021914	4202021901	1
23	Main Board	300002000286	300002000292	300002000288	1
24	Electric Box Cover Sub-Assy	0140206501	0140206501	0140206501	1
25	Shield Cover of Electric Box Cover	01592150	01592150	01592150	1
26	Electric Box Cover	20112207	2011220701	20112207	1
27	Power Cord	/	/	/	/
28	Connecting Cable	4002052317	4002052317	4002052317	0
29	Remote Controller	305001000087	305001000087	305001000087	1
30	Capacitor CBB61	33010747	3301074712	33010747	1
31	Detecting Plate	30110154	30110144	30110154	1

Above data is subject to change without notice.

NO.	Description	Part Code			Qty
		GWH09QB-K6DNB8I/I	GWH09QB-K6DND6I/I	GWH09QB-K6DNE4I/I	
	Product Code	CB438N07401	CB460N05601	CB470N02201	
1	Front Panel	20000300073T	200003000028S	200003000065T	1
2	Display Board	30565260	300001000041	300001000081	1
3	Front Case Assy	00000200040	00000200040	00000200040	1
4	Helicoid Tongue	26112508	26112508	26112508	1
5	Left Axile Bush	10512037	10512037	10512037	1
6	Rear Case assy	20162010	20162010	20162010	1
7	Drainage Hose	0523001408	0523001408	0523001408	1
8	Ring of Bearing	26152022	26152022	26152022	1
9	Evaporator Support	24212180	24212180	24212180	1
10	Cold Plasma Generator	/	/	/	/
11	Evaporator Assy	0100200004407	0100200004407	0100200004407	1
12	Wall Mounting Frame	01252043	01252043	01252043	1
13	Cross Flow Fan	10352059	10352059	10352059	1
14	Fan Motor	150120874	150120874	150120874	1
15	Connecting pipe clamp	2611216401	2611216401	2611216401	1
16	Rubber Plug (Water Tray)	76712012	76712012	76712012	1
17	Stepping Motor	1521212901	1521212901	1521212901	1
18	Crank	73012005	73012005	73012005	1
19	Electric Box Assy	100002061266	100002060403	100002003286	1
20	Axile Bush	10542036	10542036	10542036	1
21	Terminal Board	42011233	42011233	42011233	1
22	Jumper	4202021904	4202021904	4202021904	1
23	Main Board	300002000286	300002000286	300002000286	1
24	Electric Box Cover Sub-Assy	0140206501	0140206501	0140206501	1
25	Shield Cover of Electric Box Cover	01592150	01592150	01592150	1
26	Electric Box Cover	20112207	20112207	20112207	1
27	Power Cord	/	/	/	/
28	Connecting Cable	4002052317	4002052317	4002052317	0
29	Remote Controller	305001000087	305001000087	305001000087	1
30	Capacitor CBB61	33010747	33010747	33010747	1
31	Detecting Plate	30110154	30110154	30110154	1

Above data is subject to change without notice.

NO.	Description	Part Code			Qty
		GWH09QB-K6DNC2C/I	GWH12QB-K6DNE4/I	GWH12QC-K6DNC2C/I	
	Product Code	CB439N09201	CB470N02301	CB439N09403	
1	Front Panel	20000300068S	200003000065T	20000300069S	1
2	Display Board	30565281	300001000081	30565281	1
3	Front Case Assy	00000200040	00000200040	00000200045	1
4	Helicoid Tongue	26112508	26112508	26112436	1
5	Left Axile Bush	10512037	10512037	10512037	1
6	Rear Case assy	20162010	20162010	00000100093	1
7	Drainage Hose	0523001408	0523001408	05230014	1
8	Ring of Bearing	26152022	26152022	26152022	1
9	Evaporator Support	24212180	24212180	24212179	1
10	Cold Plasma Generator	/	/	/	/
11	Evaporator Assy	0100200004407	0110010009508	0100297601	1
12	Wall Mounting Frame	01252043	01252043	01252484	1
13	Cross Flow Fan	10352059	10352059	10352056	1
14	Fan Motor	150120874	150120874	15012146	1
15	Connecting pipe clamp	2611216401	2611216401	2611216401	1
16	Rubber Plug (Water Tray)	76712012	76712012	76712012	1
17	Stepping Motor	1521212901	1521212901	1521210710	1
18	Crank	73012005	73012005	73012005	1
19	Electric Box Assy	100002061997	100002062059	100002061876	1
20	Axile Bush	10542036	10542036	10542036	1
21	Terminal Board	42011233	42011233	42011233	1
22	Jumper	4202021904	4202021911	4202021914	1
23	Main Board	300002000286	30145095	300002000292	1
24	Electric Box Cover Sub-Assy	0140206501	0140206501	0140206501	1
25	Shield Cover of Electric Box Cover	01592150	01592150	01592150	1
26	Electric Box Cover	20112207	20112207	2011220701	1
27	Power Cord	/	/	/	/
28	Connecting Cable	4002052317	4002052317	4002052317	0
29	Remote Controller	305001000087	305001000087	305001000087	1
30	Capacitor CBB61	33010747	33010747	3301074712	1
31	Detecting Plate	30110154	30110154	30110144	1

Above data is subject to change without notice.

NO.	Description	Part Code			Qty
		GWH09QB-K6DNC6I/I	GWH12QB-K6DNC2I/I	GWH12QB-K6DNC2I/I	
	Product Code	CB443N05200	CB439N12700	CB439N12701	
1	Front Panel	20000300101T	20000300068S	20000300068S	1
2	Display Board	30565260	30565281	30565281	1
3	Front Case Assy	00000200040	00000200040	00000200040	1
4	Helicoid Tongue	26112508	26112508	26112508	1
5	Left Axile Bush	10512037	10512037	10512037	1
6	Rear Case assy	20162010	20162010	20162010	1
7	Drainage Hose	0523001408	0523001408	0523001408	1
8	Ring of Bearing	26152022	26152022	26152022	1
9	Evaporator Support	24212180	24212180	24212180	1
10	Cold Plasma Generator	1114001603	1114001603	/	1
11	Evaporator Assy	0100200004406	0110010009507	0110010009508	1
12	Wall Mounting Frame	01252043	01252043	01252043	1
13	Cross Flow Fan	10352059	10352059	10352059	1
14	Fan Motor	150120874	150120874	150120874	1
15	Connecting pipe clamp	2611216401	2611216401	2611216401	1
16	Rubber Plug (Water Tray)	76712012	76712012	76712012	1
17	Stepping Motor	1521212901	1521212901	1521212901	1
18	Crank	73012005	73012005	73012005	1
19	Electric Box Assy	100002003790	100002001536	100002001551	1
20	Axile Bush	10542036	10542036	10542036	1
21	Terminal Board	42011233	42011233	42011233	1
22	Jumper	4202021904	4202021911	4202021911	1
23	Main Board	300002000288	30145096	30145095	1
24	Electric Box Cover Sub-Assy	0140206501	0140206501	0140206501	1
25	Shield Cover of Electric Box Cover	01592150	01592150	01592150	1
26	Electric Box Cover	20112207	20112207	20112207	1
27	Power Cord	/	/	/	/
28	Connecting Cable	4002052317	4002052317	4002052317	0
29	Remote Controller	305001000087	305001000087	305001000087	1
30	Capacitor CBB61	33010747	33010747	33010747	1
31	Detecting Plate	30110154	30110154	30110154	1

Above data is subject to change without notice.

NO.	Description	Part Code			Qty
		GWH09QB-K6DNC2/I	GWH09QB-K6DNC8/I	GWH09QB-K6DNB4/I	
	Product Code	CB439N12600	CB456N06100	CB434N11501	
1	Front Panel	20000300068S	20000300155T	20000300026T	1
2	Display Board	30565281	30565281	30565260	1
3	Front Case Assy	00000200040	00000200040	00000200040	1
4	Helicoid Tongue	26112508	26112508	26112508	1
5	Left Axile Bush	10512037	10512037	10512037	1
6	Rear Case assy	20162010	20162010	20162010	1
7	Drainage Hose	0523001408	0523001408	0523001408	1
8	Ring of Bearing	26152022	26152022	26152022	1
9	Evaporator Support	24212180	24212180	24212180	1
10	Cold Plasma Generator	1114001603	1114001603	/	1
11	Evaporator Assy	0100200004406	0100200004406	0100200004407	1
12	Wall Mounting Frame	01252043	01252043	01252043	1
13	Cross Flow Fan	10352059	10352059	10352059	1
14	Fan Motor	150120874	150120874	150120874	1
15	Connecting pipe clamp	2611216401	2611216401	2611216401	1
16	Rubber Plug (Water Tray)	76712012	76712012	76712012	1
17	Stepping Motor	1521212901	1521212901	1521212901	1
18	Crank	73012005	73012005	73012005	1
19	Electric Box Assy	100002003076	100002003076	100002061266	1
20	Axile Bush	10542036	10542036	10542036	1
21	Terminal Board	42011233	42011233	42011233	1
22	Jumper	4202021904	4202021904	4202021904	1
23	Main Board	300002000288	300002000288	300002000286	1
24	Electric Box Cover Sub-Assy	0140206501	0140206501	0140206501	1
25	Shield Cover of Electric Box Cover	01592150	01592150	01592150	1
26	Electric Box Cover	20112207	20112207	20112207	1
27	Power Cord	/	/	/	/
28	Connecting Cable	4002052317	4002052317	4002052317	0
29	Remote Controller	305001000087	305001000087	305001000087	1
30	Capacitor CBB61	33010747	33010747	33010747	1
31	Detecting Plate	30110154	30110154	30110154	1

Above data is subject to change without notice.

NO.	Description	Part Code			Qty
		GWH09QB-K6DNB4C/I	GWH12QC-K6DNB4C/I	GWH09QB-K6DNC2I/I	
	Product Code	CB434N11301	CB434N12001	CB439N12601	
1	Front Panel	20000300026T	20000300027T	20000300068S	1
2	Display Board	30565260	30565260	30565281	1
3	Front Case Assy	00000200040	00000200045	00000200040	1
4	Helicoid Tongue	26112508	26112436	26112508	1
5	Left Axile Bush	10512037	10512037	10512037	1
6	Rear Case assy	20162010	00000100093	20162010	1
7	Drainage Hose	0523001408	05230014	0523001408	1
8	Ring of Bearing	26152022	26152022	26152022	1
9	Evaporator Support	24212180	24212179	24212180	1
10	Cold Plasma Generator	/	/	/	/
11	Evaporator Assy	0100200004407	0100297601	0100200004407	1
12	Wall Mounting Frame	01252043	01252484	01252043	1
13	Cross Flow Fan	10352059	10352056	10352059	1
14	Fan Motor	150120874	15012146	150120874	1
15	Connecting pipe clamp	2611216401	2611216401	2611216401	1
16	Rubber Plug (Water Tray)	76712012	76712012	76712012	1
17	Stepping Motor	1521212901	1521210710	1521212901	1
18	Crank	73012005	73012005	73012005	1
19	Electric Box Assy	100002061266	100002061267	100002061997	1
20	Axile Bush	10542036	10542036	10542036	1
21	Terminal Board	42011233	42011233	42011233	1
22	Jumper	4202021904	4202021914	4202021904	1
23	Main Board	300002000286	300002000292	300002000286	1
24	Electric Box Cover Sub-Assy	0140206501	0140206501	0140206501	1
25	Shield Cover of Electric Box Cover	01592150	01592150	01592150	1
26	Electric Box Cover	20112207	2011220701	20112207	1
27	Power Cord	/	/	/	/
28	Connecting Cable	4002052317	4002052317	4002052317	0
29	Remote Controller	305001000087	305001000087	305001000087	1
30	Capacitor CBB61	33010747	3301074712	33010747	1
31	Detecting Plate	30110154	30110144	30110154	1

Above data is subject to change without notice.

NO.	Description	Part Code			Qty
		GWH09QB-K6DNA2I/I	GWH09QB-K6DNA6I/I	GWH12QB-K6DNA6I/I	
Product Code		CB426N06600	CB427N10200	CB427N10300	
1	Front Panel	20022719	2002269601S	2002269601S	1
2	Display Board	300001060082	300001060082	300001060082	1
3	Front Case Assy	2002273001	2002273001	2002273001	1
4	Helicoid Tongue	26112508	26112508	26112508	1
5	Left Axile Bush	10512037	10512037	10512037	1
6	Rear Case assy	20162010	20162010	20162010	1
7	Drainage Hose	0523001408	0523001408	0523001408	1
8	Ring of Bearing	26152022	26152022	26152022	1
9	Evaporator Support	24212180	24212180	24212180	1
10	Cold Plasma Generator	1114001603	1114001603	1114001603	1
11	Evaporator Assy	0100200004406	0100200004406	0110010009507	1
12	Wall Mounting Frame	01252043	01252043	01252043	1
13	Cross Flow Fan	10352059	10352059	10352059	1
14	Fan Motor	150120874	150120874	150120874	1
15	Connecting pipe clamp	2611216401	2611216401	2611216401	1
16	Rubber Plug (Water Tray)	76712012	76712012	76712012	1
17	Stepping Motor	1521212901	1521212901	1521212901	1
18	Crank	73012005	73012005	73012005	1
19	Electric Box Assy	100002062497	100002062497	100002000251	1
20	Axile Bush	10542036	10542036	10542036	1
21	Terminal Board	42011233	42011233	42011233	1
22	Jumper	4202021904	4202021904	4202021911	1
23	Main Board	300002000288	300002000288	30145096	1
24	Electric Box Cover Sub-Assy	0140206501	0140206501	0140206501	1
25	Shield Cover of Electric Box Cover	01592150	01592150	01592150	1
26	Electric Box Cover	20112207	20112207	20112207	1
27	Power Cord	/	/	/	/
28	Connecting Cable	4002052317	4002052317	4002052317	0
29	Remote Controller	305001000087	305001000087	305001000087	1
30	Capacitor CBB61	33010747	33010747	33010747	1
31	Detecting Plate	30110154	30110154	30110154	1

Above data is subject to change without notice.

NO.	Description	Part Code			Qty
		GWH09QB-K6DNA2I/I	GWH09QB-K6DNA6I/I	GWH12QB-K6DNA6I/I	
	Product Code	CB426N06600	CB427N10200	CB427N10300	
1	Front Panel	20022719	2002269601S	2002269601S	1
2	Display Board	300001060082	300001060082	300001060082	1
3	Front Case Assy	2002273001	2002273001	2002273001	1
4	Helicoid Tongue	26112508	26112508	26112508	1
5	Left Axile Bush	10512037	10512037	10512037	1
6	Rear Case assy	20162010	20162010	20162010	1
7	Drainage Hose	0523001408	0523001408	0523001408	1
8	Ring of Bearing	26152022	26152022	26152022	1
9	Evaporator Support	24212180	24212180	24212180	1
10	Cold Plasma Generator	1114001603	1114001603	1114001603	1
11	Evaporator Assy	0100200004406	0100200004406	0110010009507	1
12	Wall Mounting Frame	01252043	01252043	01252043	1
13	Cross Flow Fan	10352059	10352059	10352059	1
14	Fan Motor	150120874	150120874	150120874	1
15	Connecting pipe clamp	2611216401	2611216401	2611216401	1
16	Rubber Plug (Water Tray)	76712012	76712012	76712012	1
17	Stepping Motor	1521212901	1521212901	1521212901	1
18	Crank	73012005	73012005	73012005	1
19	Electric Box Assy	100002062497	100002062497	100002000251	1
20	Axile Bush	10542036	10542036	10542036	1
21	Terminal Board	42011233	42011233	42011233	1
22	Jumper	4202021904	4202021904	4202021911	1
23	Main Board	300002000288	300002000288	30145096	1
24	Electric Box Cover Sub-Assy	0140206501	0140206501	0140206501	1
25	Shield Cover of Electric Box Cover	01592150	01592150	01592150	1
26	Electric Box Cover	20112207	20112207	20112207	1
27	Power Cord	/	/	/	/
28	Connecting Cable	4002052317	4002052317	4002052317	0
29	Remote Controller	305001000087	305001000087	305001000087	1
30	Capacitor CBB61	33010747	33010747	33010747	1
31	Detecting Plate	30110154	30110154	30110154	1

Above data is subject to change without notice.

NO.	Description	Part Code	Qty
		GWH09QB-K6DND8I/I	
Product Code		CB459N05000	
1	Front Panel	200003000010S	1
2	Display Board	300001000035	1
3	Front Case Assy	00000200040	1
4	Helicoid Tongue	26112508	1
5	Left Axile Bush	10512037	1
6	Rear Case assy	20162010	1
7	Drainage Hose	0523001408	1
8	Ring of Bearing	26152022	1
9	Evaporator Support	24212180	1
10	Cold Plasma Generator	1114001603	1
11	Evaporator Assy	0100200004406	1
12	Wall Mounting Frame	01252043	1
13	Cross Flow Fan	10352059	1
14	Fan Motor	150120874	1
15	Connecting pipe clamp	2611216401	1
16	Rubber Plug (Water Tray)	76712012	1
17	Stepping Motor	1521212901	1
18	Crank	73012005	1
19	Electric Box Assy	100002002490	1
20	Axile Bush	10542036	1
21	Terminal Board	42011233	1
22	Jumper	4202021904	1
23	Main Board	300002000288	1
24	Electric Box Cover Sub-Assy	0140206501	1
25	Shield Cover of Electric Box Cover	01592150	1
26	Electric Box Cover	20112207	1
27	Power Cord	/	/
28	Connecting Cable	4002052317	0
29	Remote Controller	305001000087	1
30	Capacitor CBB61	33010747	1
31	Detecting Plate	30110154	1

Above data is subject to change without notice.

18K

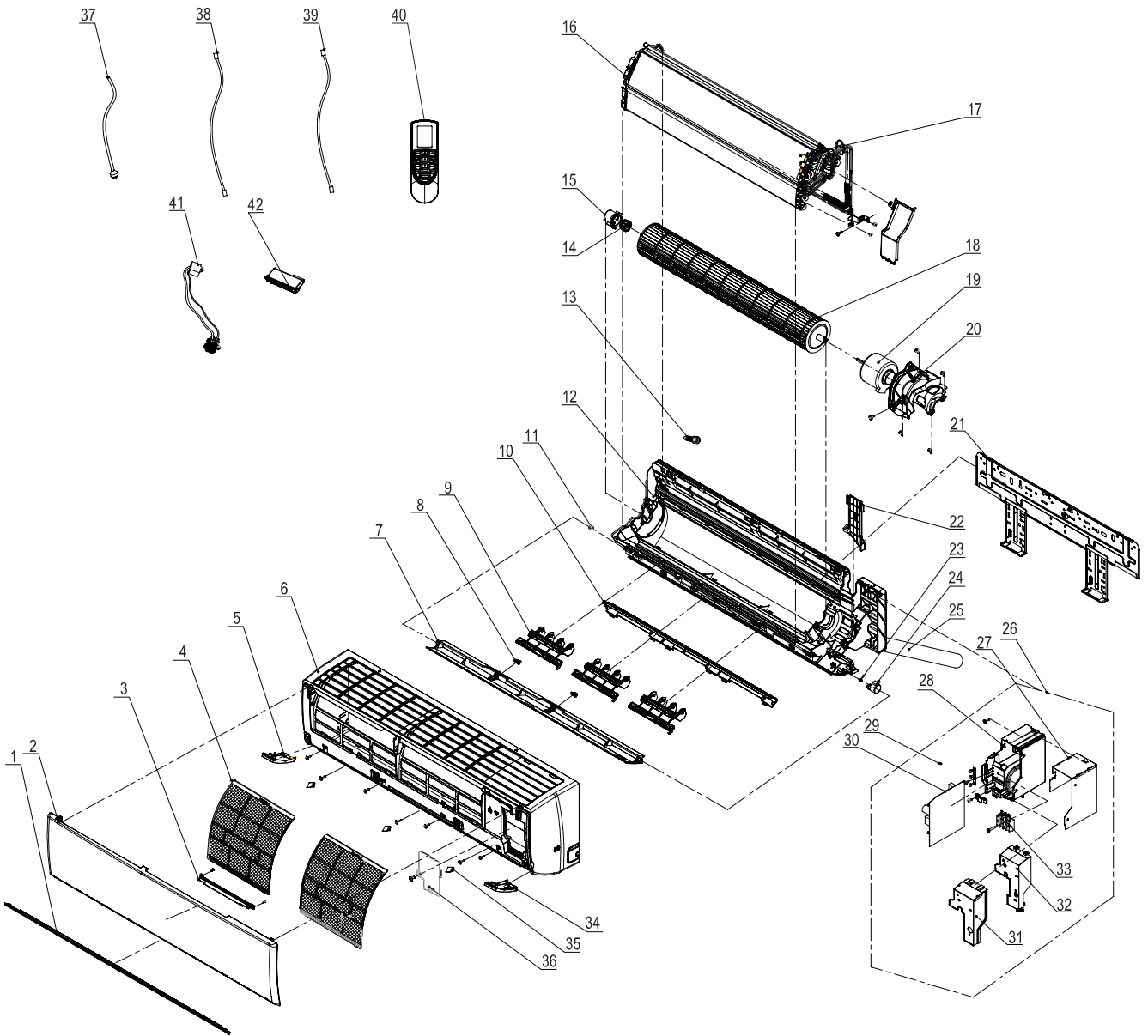

The component picture is only for reference; please refer to the actual product.



NO.	Description	Part Code			Qty
		GWH18QD-K6DNC8C/I	GWH18QD-K6DNB4B/I	GWH18QD-K6DND8B/I	
		Product Code			
1	Decorative Strip	/	/	23000500002401P	1
2	Front Panel	20000300153T	20000300028	200003000015S	1
3	Display Board	30565278	30565260	300001000036	1
4	Filter Sub-Assy	11122089	11122089	1112208906	2
5	Decorative Board (Left)	20192662	20192662	20192662	1
6	Front Case	2002248401	2002248401	2002248401	1
7	Guide Louver	1051276501	1051276501	1051276501	1
8	Axile Bush	10542036	10542036	10542036	2
9	Air Louver	1051276501	1051276501	1051276501	1
10	Helicoid tongue	26112512	26112512	26112512	1
11	Left Axile Bush	10512037	10512037	10512037	1
12	Rear Case assy	22202571	22202571	22202571	1
13	Rubber Plug (Water Tray)	76712012	76712012	76712012	1
14	O-Gasket sub-assy of Bearing	7651205102	7651205102	76512051	1
15	Ring of Bearing	26152025	26152025	26152025	1
16	Evaporator Support	24212177	24212177	24212177	1
17	Evaporator Assy	011001000207	01100100020401	01100100020401	1
18	Cross Flow Fan	10352060	10352060	10352060	1
19	Fan Motor	1501214502	1501214502	1501214502	1
20	Motor Press Plate	26112511	26112511	26112511	1
21	Wall Mounting Frame	01362026	01362026	01362026	1
22	Connecting pipe clamp	2611218801	2611218801	2611218801	1
23	Crank	73012005	73012005	73012005	1
24	Stepping Motor	1521240212	1521240212	1521240212	1
25	Drainage hose	05230014	05230014	05230014	1
26	Electric Box Assy	100002003061	100002003619	100002062477	1
27	Lower Shield of Electric Box	01592139	01592139	01592139	1
28	Electric Box	20112211	20112211	20112211	1
29	Jumper	4202021921	4202021921	4202021921	1
30	Main Board	300002000296	300002000397	300002000397	1
31	Shield Cover of Electric Box	01592176	01592176	01592176	1
32	Electric Box Cover	20112209	20112209	20112209	1
33	Terminal Board	42011233	42011233	42011233	1
34	Decorative Board (Right)	20192662	20192662	20192662	1
35	Screw Cover	2425201726	2425201726	2425201726	3
36	Electric Box Cover2	20112210	20112210	20112210	1
37	Power Cord	/	/	/	/
38	Connecting Cable	4002052317	4002052317	4002052317	0
39	Connecting Cable	/	/	/	/
40	Remote Controller	30510474	30510474	305001000087	1
41	Cold Plasma Generator	1114001602	1114001602	1114001602	1
42	Detecting Plate	30110144	30110144	30110144	1

Above data is subject to change without notice.

NO.	Description	Part Code		Qty
		GWH18QD-K6DNA1B/I	GWH18QD-K6DND6B/I	
		Product Code		
		CB419N15200	CB460N05301	
1	Decorative Strip	20192613	/	1
2	Front Panel	20022481S	200003000027S	1
3	Display Board	30565262	300001000042	1
4	Filter Sub-Assy	11122089	1112208906	2
5	Decorative Board (Left)	2019269303	20192662	1
6	Front Case	20022484	2002248401	1
7	Guide Louver	10512734	1051276501	1
8	Axile Bush	10542036	10542036	2
9	Air Louver	10512734	1051276501	1
10	Helicoid tongue	26112512	26112512	1
11	Left Axile Bush	10512037	10512037	1
12	Rear Case assy	22202571	22202571	1
13	Rubber Plug (Water Tray)	76712012	76712012	1
14	O-Gasket sub-assy of Bearing	7651205102	7651205102	1
15	Ring of Bearing	26152025	26152025	1
16	Evaporator Support	24212177	24212177	1
17	Evaporator Assy	01100100020401	01100100020401	1
18	Cross Flow Fan	10352060	10352060	1
19	Fan Motor	1501214502	1501214502	1
20	Motor Press Plate	26112511	26112511	1
21	Wall Mounting Frame	01362026	01362026	1
22	Connecting pipe clamp	2611218801	2611218801	1
23	Crank	73012005	73012005	1
24	Stepping Motor	1521240212	1521240212	1
25	Drainage hose	05230014	05230014	1
26	Electric Box Assy	100002060842	100002061612	1
27	Lower Shield of Electric Box	01592139	01592139	1
28	Electric Box	20112211	20112211	1
29	Jumper	4202021912	4202021921	1
30	Main Board	300002000397	300002000397	1
31	Shield Cover of Electric Box	01592176	01592176	1
32	Electric Box Cover	20112209	20112209	1
33	Terminal Board	42011233	42011233	1
34	Decorative Board (Right)	2019269303	20192662	1
35	Screw Cover	242520179	2425201726	3
36	Electric Box Cover2	20112210	20112210	1
37	Power Cord	/	/	/
38	Connecting Cable	4002052317	4002052317	0
39	Connecting Cable	/	/	/
40	Remote Controller	305001000087	305001000087	1
41	Cold Plasma Generator	1114001602	1114001602	1
42	Detecting Plate	30110144	30110144	1

Above data is subject to change without notice.

NO.	Description	Part Code		Qty
		GWH18QD-K6DNA5B/I	GWH18QD-K6DNB4B/I	
		Product Code		
		CB425N11900	CB434N11201	
1	Decorative Strip	/	/	/
2	Front Panel	2002266901S01	20000300028T	1
3	Display Board	30565260	30565260	1
4	Filter Sub-Assy	1112208906	1112208906	2
5	Decorative Board (Left)	2019261201	20192662	1
6	Front Case	2002248401	2002248401	1
7	Guide Louver	1051273402	1051276501	1
8	Axile Bush	10542036	10542036	2
9	Air Louver	1051273402	1051276501	1
10	Helicoid tongue	26112512	26112512	1
11	Left Axile Bush	10512037	10512037	1
12	Rear Case assy	22202571	22202571	1
13	Rubber Plug (Water Tray)	76712012	76712012	1
14	O-Gasket sub-assy of Bearing	7651205102	7651205102	1
15	Ring of Bearing	26152025	26152025	1
16	Evaporator Support	24212177	24212177	1
17	Evaporator Assy	01100100020401	01100100020401	1
18	Cross Flow Fan	10352060	10352060	1
19	Fan Motor	1501214502	1501214502	1
20	Motor Press Plate	26112511	26112511	1
21	Wall Mounting Frame	01362026	01362026	1
22	Connecting pipe clamp	2611218801	2611218801	1
23	Crank	73012005	73012005	1
24	Stepping Motor	1521240212	1521240212	1
25	Drainage hose	05230014	05230014	1
26	Electric Box Assy	100002062109	100002062057	1
27	Lower Shield of Electric Box	01592139	01592139	1
28	Electric Box	20112211	20112211	1
29	Jumper	4202021912	4202021921	1
30	Main Board	300002000397	300002000398	1
31	Shield Cover of Electric Box	01592176	01592176	1
32	Electric Box Cover	20112209	20112209	1
33	Terminal Board	42011233	42011233	1
34	Decorative Board (Right)	2019261101	20192662	1
35	Screw Cover	2425201726	2425201726	3
36	Electric Box Cover2	20112210	20112210	1
37	Power Cord	/	/	/
38	Connecting Cable	4002052317	4002052317	0
39	Connecting Cable	/	/	/
40	Remote Controller	305001000087	305001000087	1
41	Cold Plasma Generator	1114001602	/	1
42	Detecting Plate	30110144	30110144	1

Above data is subject to change without notice.

10.2 Outdoor Unit

GWH09QB-K6DNA1C/O

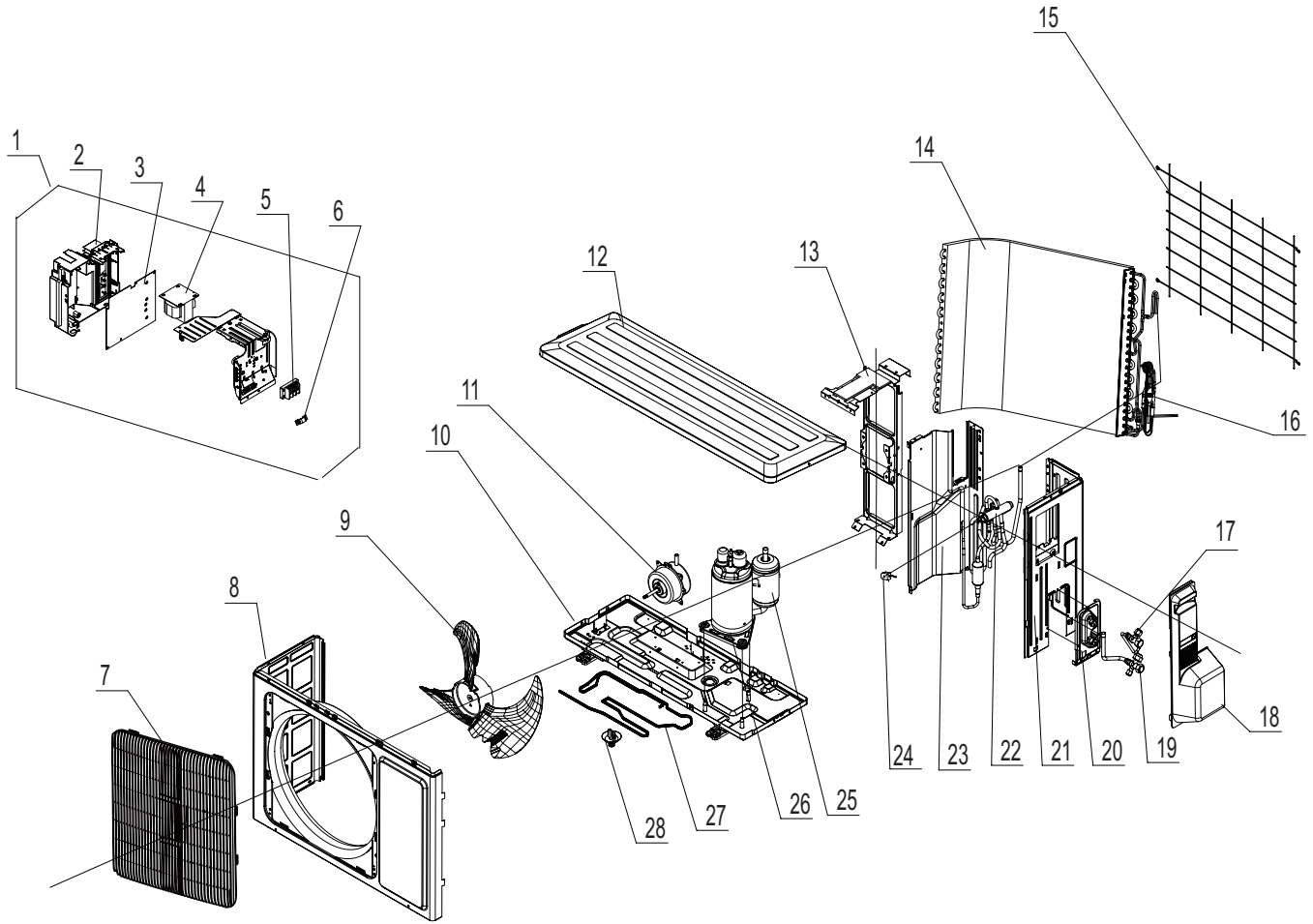

The component picture is only for reference; please refer to the actual product.

NO.	Description	Part Code		Qty
		GWH09QB-K6DNA1C/O		
		Product Code		
		CB419W11900	CB419W11901	
1	Electric Box Assy	100002001193	100002001207	1
2	Electric Box	20113034	20113034	1
3	Main Board	300027000249	300027000250	1
4	Reactor	43130184	43130184	1
5	Terminal Board	42010313	42010313	1
6	Wire Clamp	71010103	71010103	2
7	Front Grill	22413043	22413043	1
8	Front Panel	01533034P	01533034P	1
9	Axial Flow Fan	10333428	10333428	1
10	Chassis Sub-assy	017000000134P	017000000133P	1
11	Brushless DC Motor	1501308511	1501308511	1
12	Top Cover Sub-Assy	01253073	01253073	1
13	Motor Support	01703104	01703104	1
14	Condenser Assy	011002000372	011002000372	1
15	Rear Grill	01473009	01473009	1
16	Capillary Sub-assy	030006000337	030006000337	1
17	Cut off Valve	071302391	071302391	1
18	Big Handle	262334332	262334332	1
19	Cut off Valve	07130239	07130239	1
20	Valve Support	0171314201P	0171314201P	1
21	Right Side Plate Sub-Assy	0130317801	0130317801	1
22	4-Way Valve Assy	030152000171	030152000171	1
23	Clapboard Sub-Assy	0123338502	0123338502	1
24	Magnet Coil	4300040050	4300040050	1
25	Compressor and Fittings	00103925G	00103925G	1
26	Electrical Heater	/	7651300403	1
27	Electrical Heater (Chassis)	/	7651000414	1
28	Drainage Connector	06123401	06123401	1

Above data is subject to change without notice.

GWH09QB-K6DNB8I/O GWH09QB-K6DNA1C/O

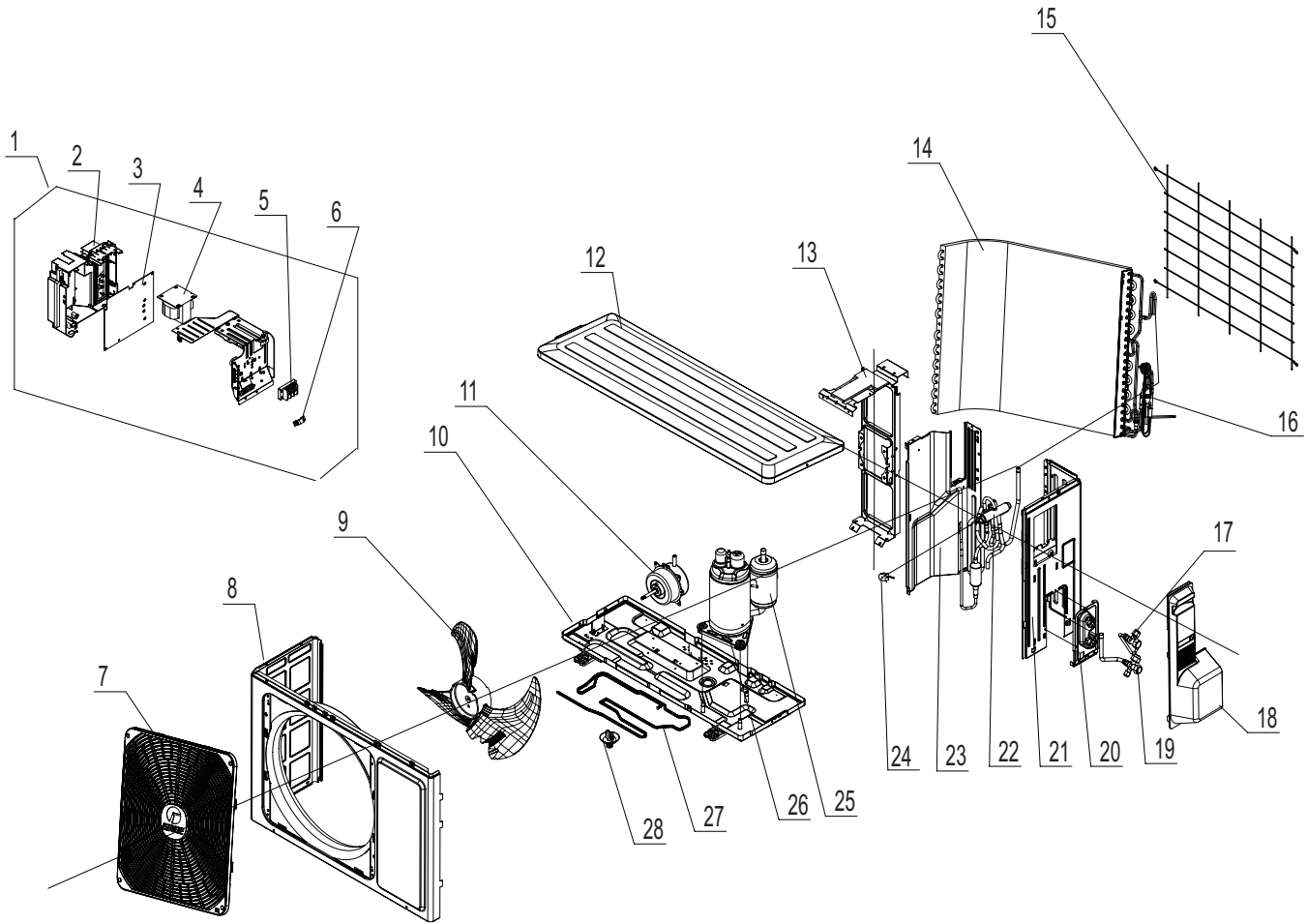

The component picture is only for reference; please refer to the actual product.

NO.	Description	Part Code		Qty
		GWH09QB-K6DNB8I/O	GWH09QB-K6DNA1C/O	
		Product Code		
1	Electric Box Assy	100002001193	100002002657	1
2	Electric Box	20113034	20113034	1
3	Main Board	300027000249	300027000249	1
4	Reactor	43130184	43130184	1
5	Terminal Board	42010313	42010313	1
6	Wire Clamp	71010103	71010103	2
7	Front Grill	22413049	22413049	1
8	Front Panel	01533034P	01533034P	1
9	Axial Flow Fan	10333004	10333004	1
10	Chassis Sub-assy	017000000134P	017000000134P	1
11	Brushless DC Motor	1501308507	1501308507	1
12	Top Cover Sub-Assy	01253073	01253073	1
13	Motor Support	01703104	01703104	1
14	Condenser Assy	011002000372	011002000372	1
15	Rear Grill	01473009	01473009	1
16	Capillary Sub-assy	030006000337	030006000337	1
17	Cut off Valve	071302391	071302391	1
18	Big Handle	262334332	2623343106	1
19	Cut off Valve	07130239	07130239	1
20	Valve Support	0171314201P	01713142P	1
21	Right Side Plate Sub-Assy	0130317801	01303178	1
22	4-Way Valve Assy	030152000171	030152000171	1
23	Clapboard Sub-Assy	0123338502	0123338502	1
24	Magnet Coil	4300040050	4300040050	1
25	Compressor and Fittings	00103925G	00103925G	1
26	Electrical Heater	/	/	/
27	Electrical Heater (Chassis)	/	/	/
28	Drainage Connector	06123401	06123401	1

Above data is subject to change without notice.

GWH12QC-K6DNA1C/O GWH12QB-K6DNB8I/O GWH18AAD-K6DNA1B/O

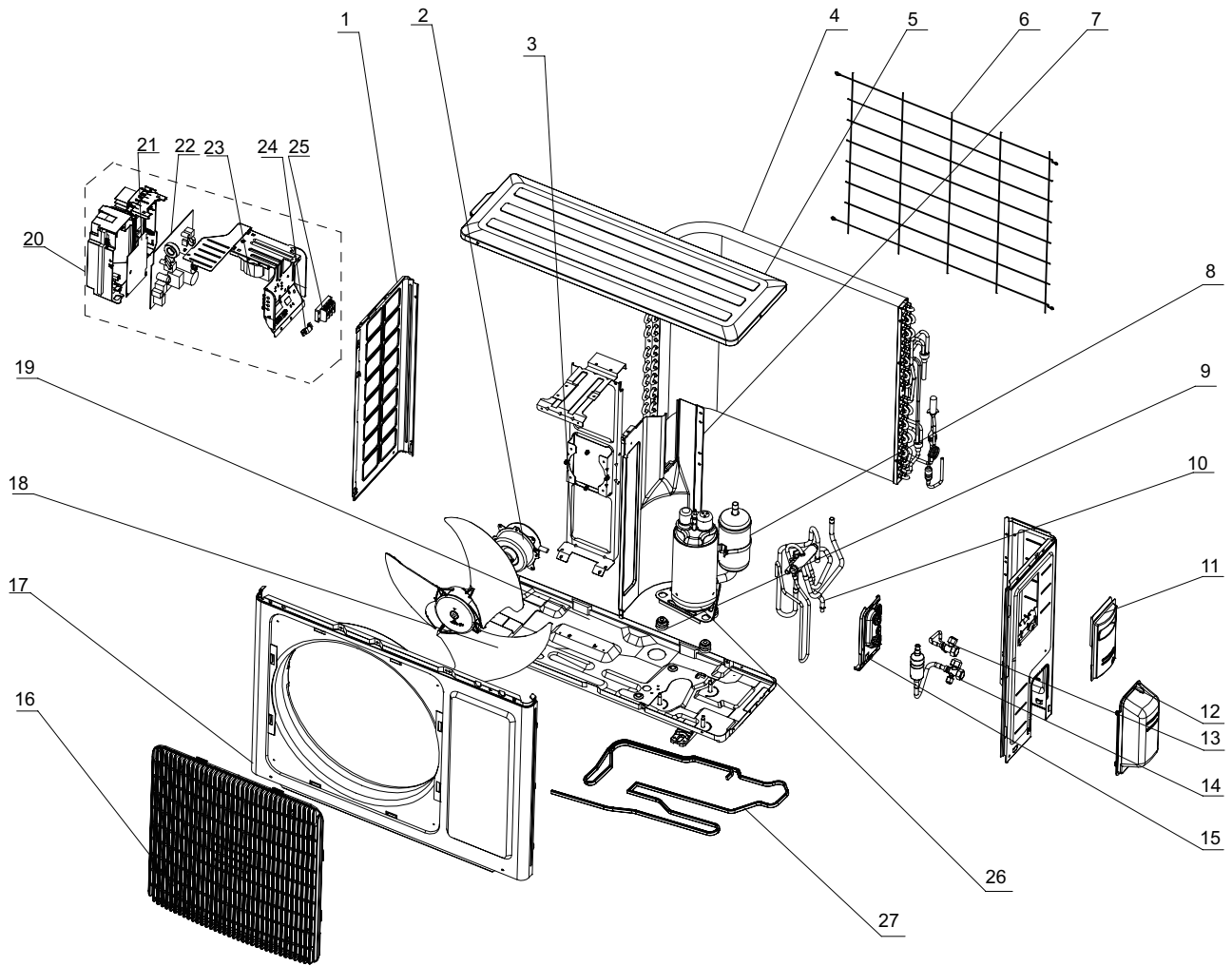

The component picture is only for reference; please refer to the actual product.

NO.	Description	Part Code			Qty
		GWH12QC-K6DNA1C/O		GWH18AAD-K6DNA1B/O	
		Product Code	CB419W12300	CB419W12301	
1	Left Side Plate	01303200P	01303200P	01303200P	1
2	Fan Motor	1501308507	1501308507	1501308507	1
3	Motor Support	01703136	01703136	01703136	1
4	Condenser Assy	011002000359	011002000359	011002000529	1
5	Top Cover Sub-Assy	01253081	01253081	01253081	1
6	Rear Grill	01475014	01475014	01475014	1
7	Clapboard Sub-Assy	01233180	01233180	01233180	1
8	Compressor and Fittings	00103925G	00103925G	00103925G	1
9	Compressor Gasket	76710287	76710287	76710287	3
10	4-Way Valve Assy	030152000016	030152000016	030152000158	1
11	Big Handle	2623343106	2623343106	2623343106	1
12	Valve Cover	22243006	22243006	22243006	1
13	Cut off Valve	071302391	071302391	071302391	1
14	Cut off Valve	07130239	07130239	07130239	1
15	Valve Support	0171314201P	0171314201P	0171314201P	1
16	Front Grill	22413044	22413044	22413044	1
17	Cabinet	01433033P	01433033P	01433033P	1
18	Axial Flow Fan	10333011	10333011	10333011	1
19	Chassis Sub-assy	017000000091P	017000000199P	02803213P	1
20	Electric Box Assy	100002001110	100002001117	100002001857	1
21	Electric Box	20113032	20113032	20113034	1
22	Main Board	300027000261	300027000262	300027000337	1
23	Reactor	43130184	43130184	43130184	1
24	Wire Clamp	71010103	71010103	71010103	2
25	Terminal Board	42010313	42010313	42010313	1
26	Electrical Heater	/	7651300403	/	1
27	Electrical Heater (Chassis)	/	7651000414	/	1

Above data is subject to change without notice.

NO.	Description	Part Code	Qty
		GWH12QB-K6DNB8I/O	
	Product Code	CB438W06800	
1	Left Side Plate	01303200P	1
2	Fan Motor	1501308507	1
3	Motor Support	01703136	1
4	Condenser Assy	011002000588	1
5	Top Cover Sub-Assy	000051060003	1
6	Rear Grill	01475014	1
7	Clapboard Sub-Assy	01233180	1
8	Compressor and Fittings	009001000175	1
9	Compressor Gasket	76710287	3
10	4-Way Valve Assy	030152000016	1
11	Big Handle	2623343106	1
12	Valve Cover	22243006	1
13	Cut off Valve	071302391	1
14	Cut off Valve	07130239	1
15	Valve Support	0171314201P	1
16	Front Grill	22413044	1
17	Cabinet	01433033P	1
18	Axial Flow Fan	10333011	1
19	Chassis Sub-assy	017000000091P	1
20	Electric Box Assy	100002002902	1
21	Electric Box	20113034	1
22	Main Board	300027000482	1
23	Reactor	43130184	1
24	Wire Clamp	71010103	2
25	Terminal Board	42010313	1
26	Electrical Heater	/	/
27	Electrical Heater (Chassis)	/	/

Above data is subject to change without notice.

GWH18QD-K6DNA1C/O

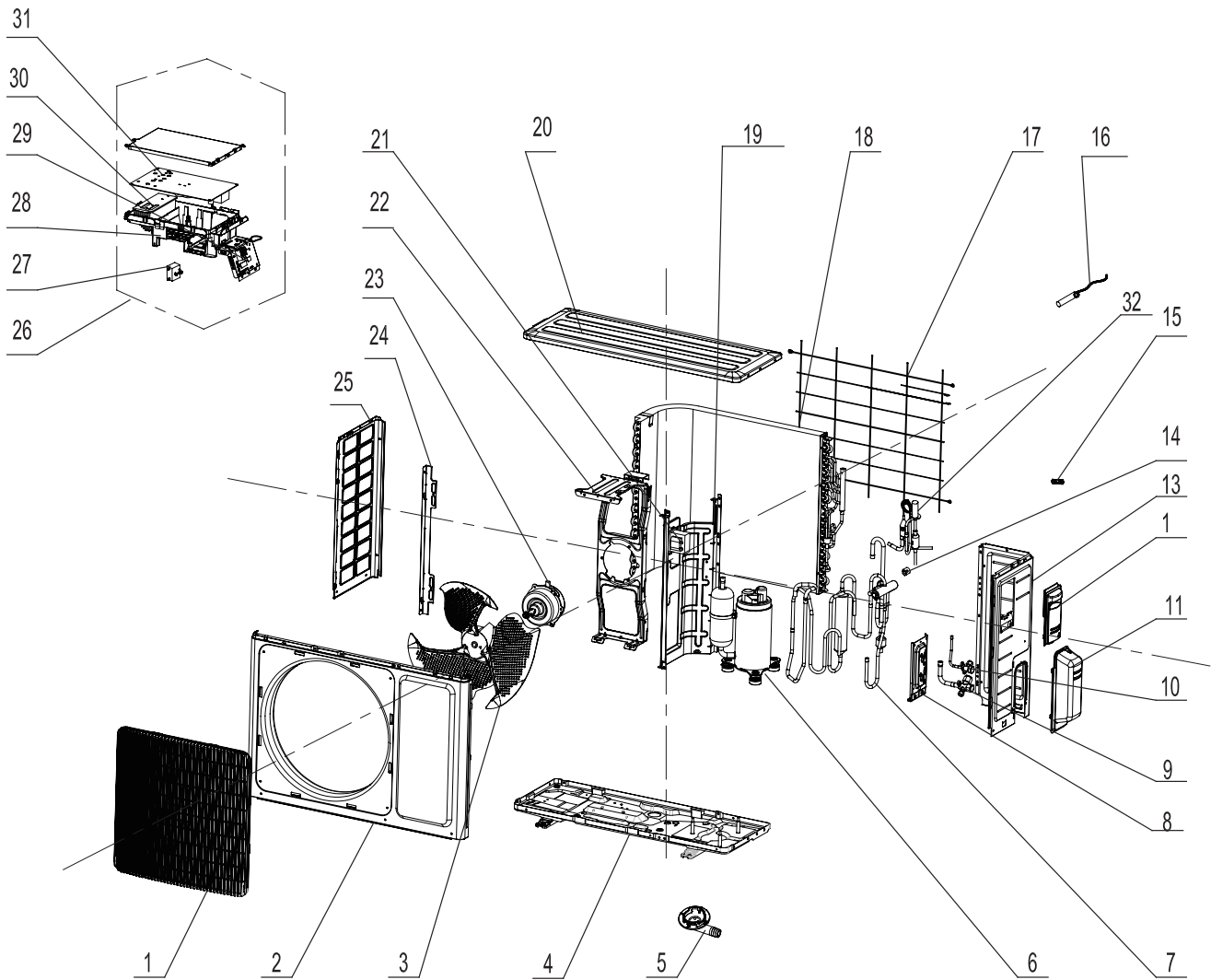

The component picture is only for reference; please refer to the actual product.

No.	Description	Part Code	Qty
		GWH18QD-K6DNA1C/O	
		Product Code	
		CB419W12500	
1	Front Grill	22413046	1
2	Cabinet	01433034P	1
3	Axial Flow Fan	10333014	1
4	Chassis Sub-assy	01205176P	1
5	Drainage Joint	26113009	1
6	Compressor and Fittings	00103919G	1
7	4-Way Valve Assy	030152000146	1
8	Valve Support Sub-Assy	01713115P	1
9	Cut off Valve Sub-Assy	030057000072	1
10	Cut off Valve Assy	07133774	1
11	Valve Cover	22243005	1
12	Big Handle	2623343106	1
13	Right Side Plate	0130324403P	1
14	4 Way Valve Coil	4300040087	1
15	Wire Clamp	71010103	1
16	Temperature Sensor	3900030902	1
17	Rear Grill	01473060	1
18	Condenser Assy	011002000417	1
19	Clapboard Sub-Assy	01233168	1
20	Coping	01253034P	1
21	Reactor	/	/
22	Motor Support Sub-Assy	0170339802	1
23	Fan Motor	1501371701	1
24	Condenser Support Plate	01795028	1
25	Left Side Plate	01303169P	1
26	Electric Box Assy	100002001268	1
27	Capacitor CBB61	/	/
28	Electric Box	20113027	1
29	Terminal Board	420101943	1
30	Radiator	49013060	1
31	Main Board	300027000175	1
32	Electric Expansion Valve Sub-Assy	030026000166	1

Above data is subject to change without notice.

11. Removal Procedure

09/12K

⚠ Caution: discharge the refrigerant completely before removal.

11.1 Removal Procedure of Indoor Unit

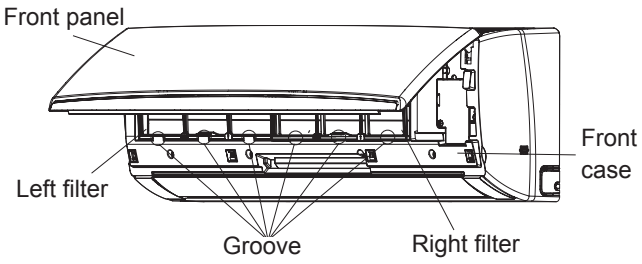
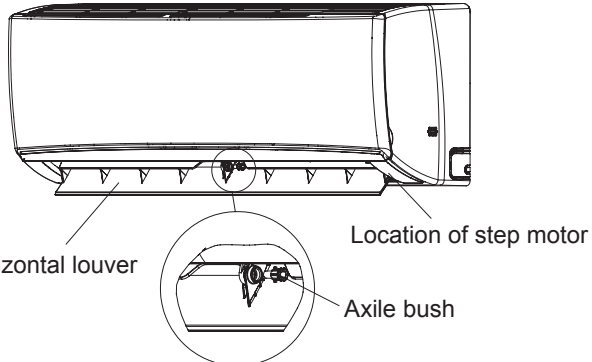
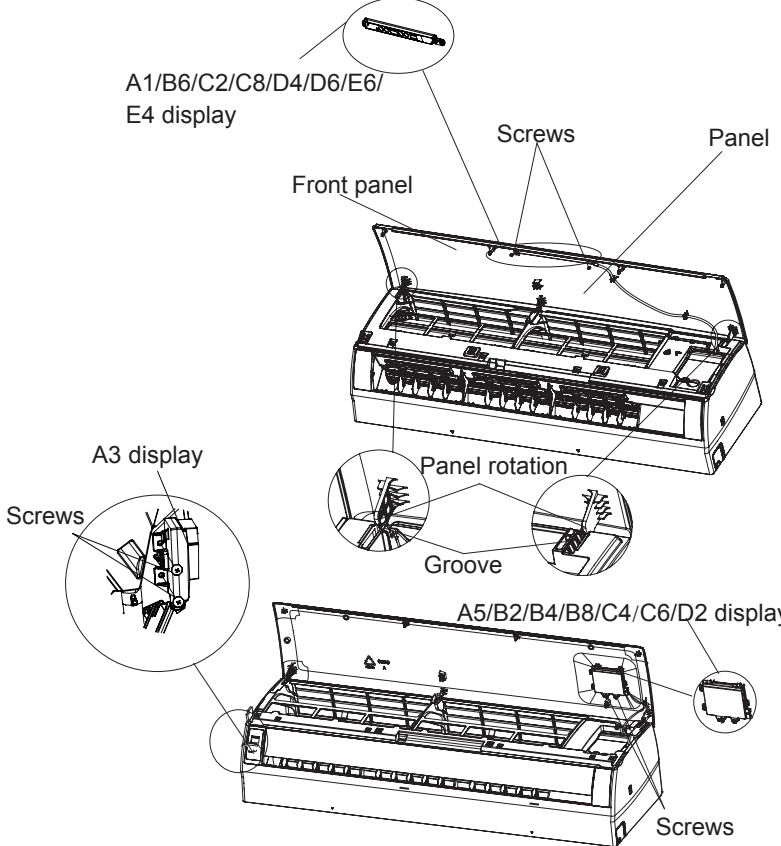
Step	Procedure
1. Remove filter assembly	<p>Open the front panel. Push the left filter and right filter until they are separate from the groove on the front panel. Remove the left filter and right filter respectively.</p> 
2. Remove horizontal louver	<p>Push out the axle bush on horizontal louver. Bend the horizontal louver with hand and then separate the horizontal louver from the crankshaft of step motor to remove it.</p> 
3. Remove panel	<p>a</p> <p>① A1/B6/C2/C4 display: Screw off the 2 screws that are locking the display board. Separate the display board from the front panel.</p> <p>② A2/A3 display: Screw off the 2 screws that are locking the display board. This display can be disassembled only after removing the front case (refer to step 5 of disassembly).</p> <p>③ A5/B2/B4/B8/C6/D2 display: Screw off the 2 screws that are locking the display board.</p> <p>b</p> <p>Separate the panel rotation shaft from the groove fixing the front panel and then removes the front panel.</p> 

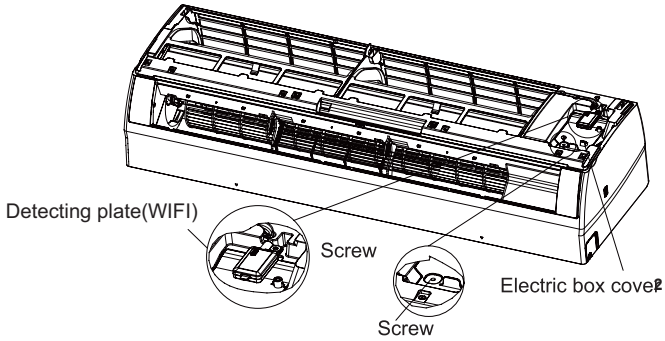
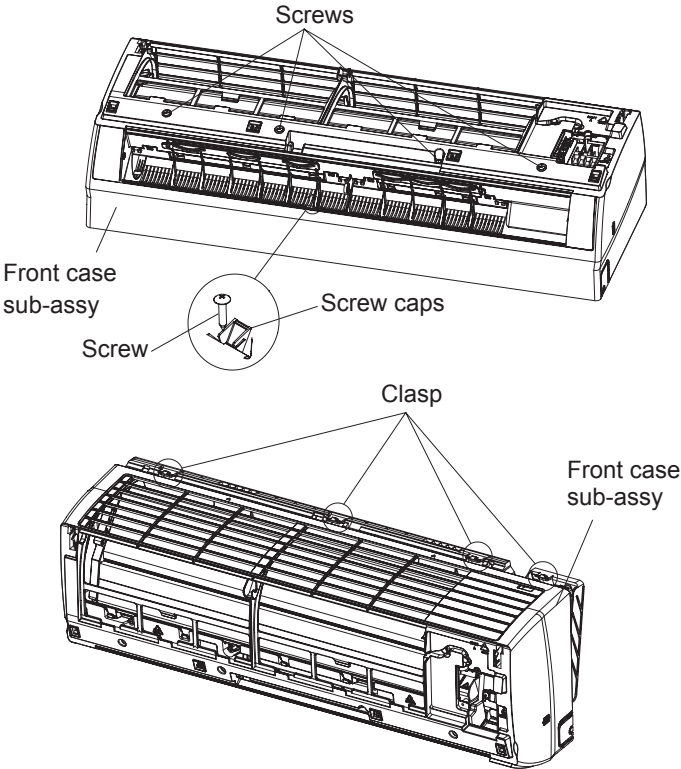
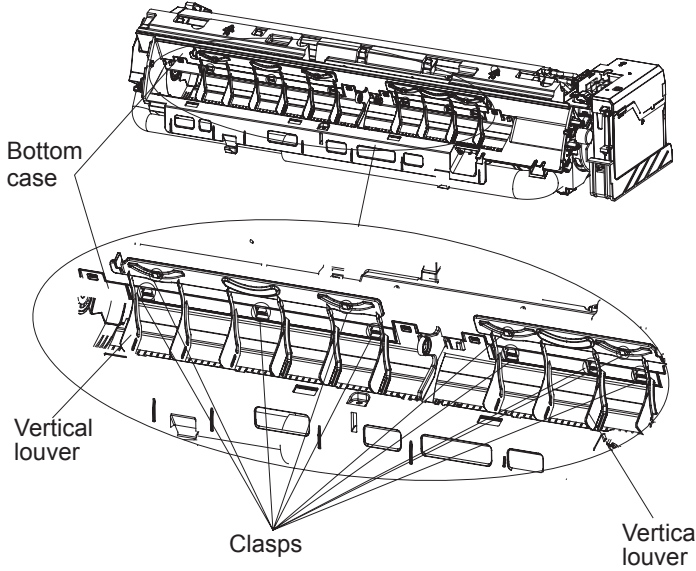
Step	Procedure	Diagram
4. Remove detecting plate(wifi) and electric box cover2	<p>Remove the screws fixing detecting plate and remove detecting plate(wifi).</p> <p>Remove the screws fixing electric box cover2 and remove electric box2.</p>	
5. Remove front case sub-assy	<p>a Remove the screws fixing front case.</p> <p>Note: 1.Open the screw caps before removing the screws around the air outlet. 2.The quantity of screws fixing the front case sub-assy is different for different models.</p> <p>b Loosen the connection clasps between front case sub-assy and bottom case. Lift up the front case sub-assy and take it out.</p>	
6. Remove vertical louver	<p>Loosen the connection clasps between vertical louver and bottom case to remove vertical louver.</p>	

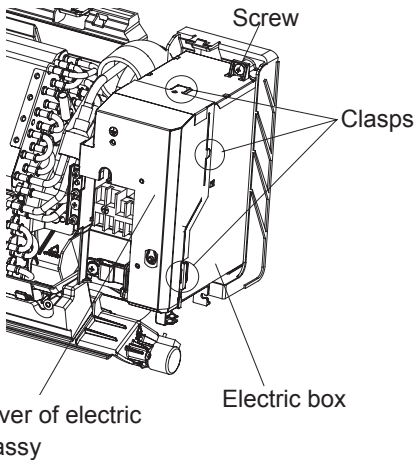
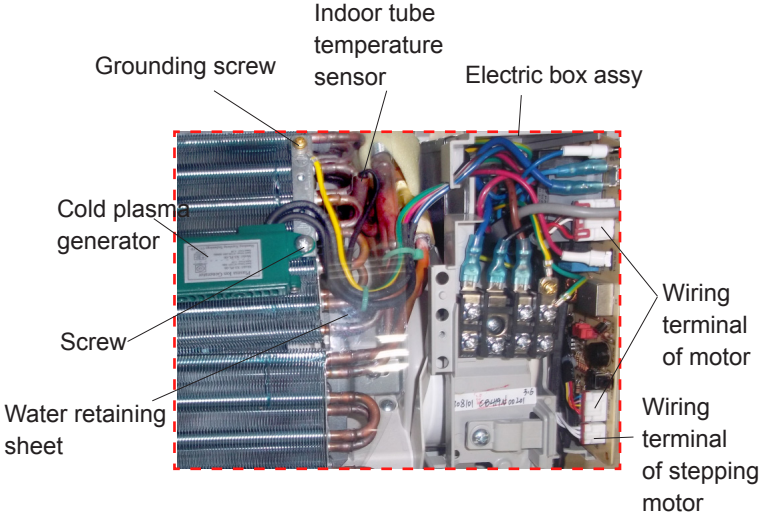
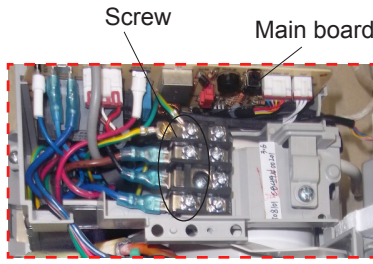
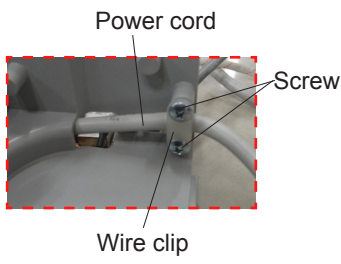
Step	Procedure
7. Remove electric box assy	
a	<p>Loosen the connection clasps between shield cover of electric box sub-assy and electric box, and then remove the shield cover of electric box sub-assy. Remove the screw fixing electric box assy .</p> 
b	<p>① Take off the water retaining sheet. Remove the cold plasma generator by screwing off the locking screw on the generator. ② Take off the indoor tube temperature sensor. ③ Screw off 1 grounding screw. ④ Remove the wiring terminals of motor and stepping motor. ⑤ Remove the electric box assy.</p> 
c	<p>Twist off the screws that are locking each lead wire and rotate the electric box assy. Twist off the screws that are locking the wire clip. Loosen the power cord and remove its wiring terminal. Lift up the main board and take it off.</p>  

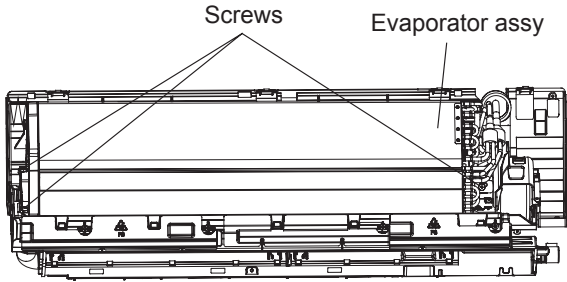
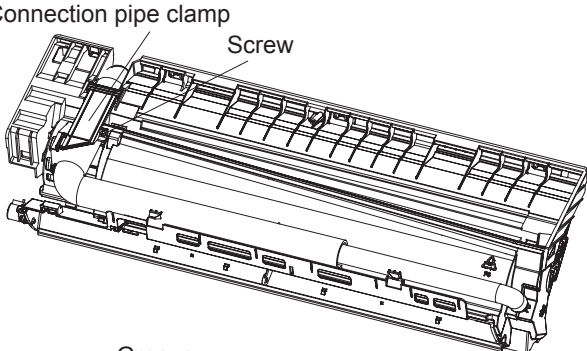
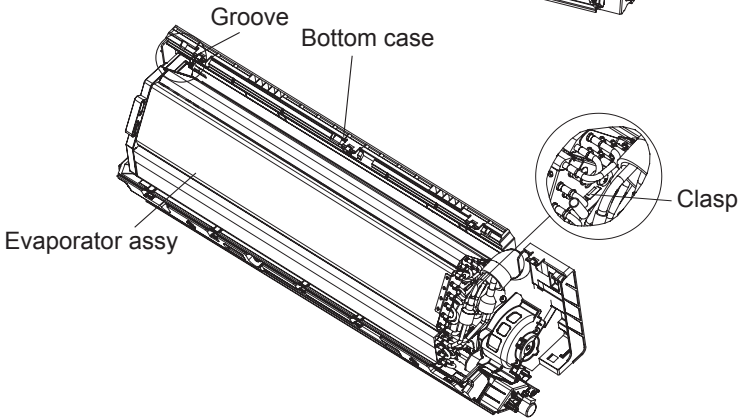
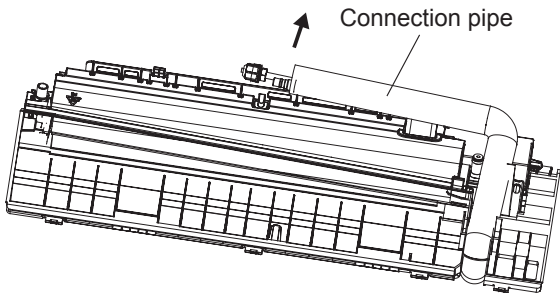
Step	Procedure	
	<p>Instruction: Some wiring terminal of this product is with lock catch and other devices. The pulling method is as below:</p> <p>1.Remove the soft sheath for some terminals at first, hold the circlip and then pull out the terminals.</p> <p>2.Pull out the holder for some terminals at first (holder is not available for some wiring terminal), hold the connector and then pull the terminal.</p>	 <p>Labels: circlip, soft sheath, holder, connector</p>
8. Remove evaporator assy		
a	Remove 3 screws fixing evaporator assy.	 <p>Labels: Screws, Evaporator assy</p>
b	At the back of the unit, remove the screw fixing connection pipe clamp and then remove the connection pipe clamp.	 <p>Labels: Connection pipe clamp, Screw</p>
c	First remove the left side of the evaporator from the groove of bottom case and then remove the right side from the clasp on the bottom case.	 <p>Labels: Groove, Bottom case, Evaporator assy, Clasp</p>
d	Adjust the position of connection pipe on evaporator slightly and then lift the evaporator upwards to remove it.	 <p>Labels: Connection pipe</p>

Step	Procedure
9. Remove motor and cross flow blade	
a	<p>Remove the screws fixing motor clamp and then remove the motor clamp.</p>
b	<p>Remove the screws at the connection place of cross flow blade and motor; lift the motor and cross flow blade upwards to remove them. Remove the bearing holder sub-assy. Remove the screw fixing step motor and then remove the step motor.</p>

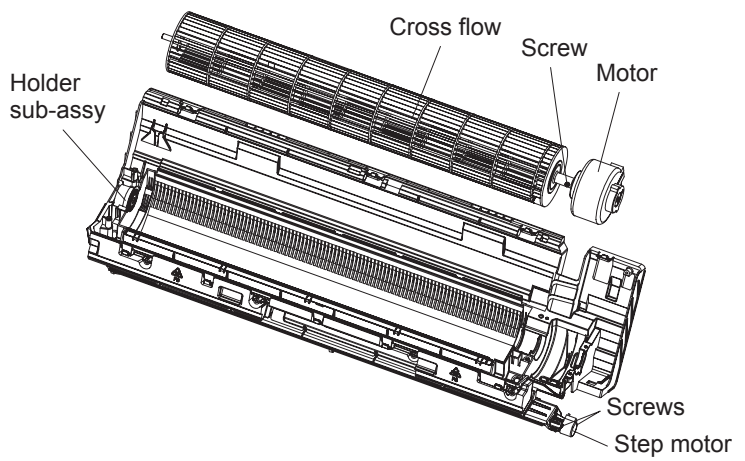
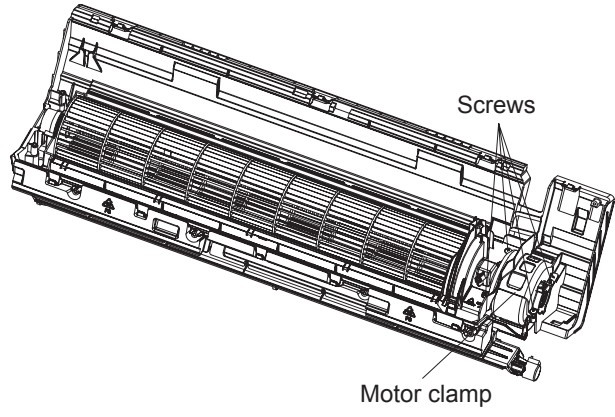

18K

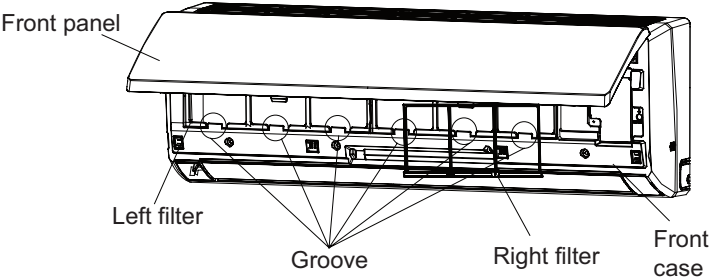
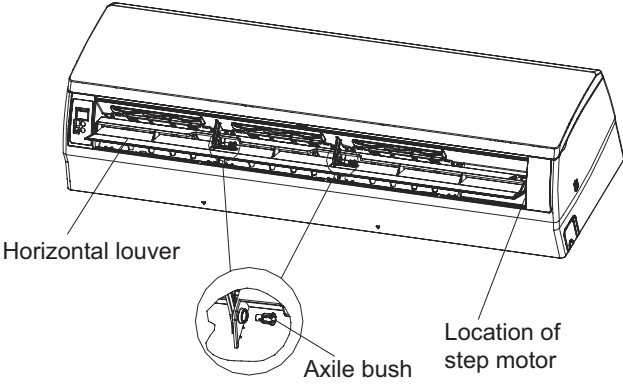
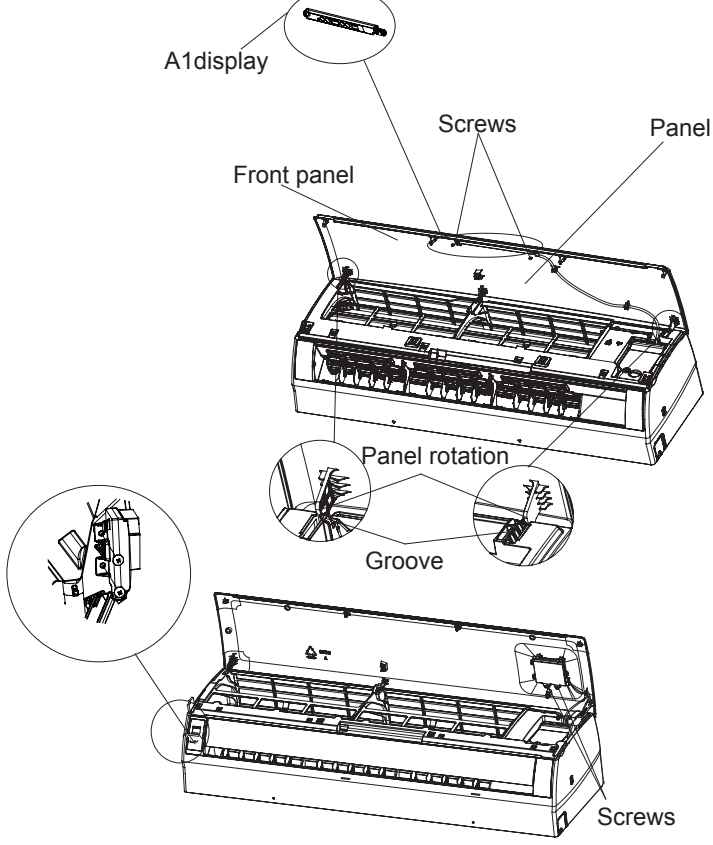
Step	Procedure	Procedure
1.Remove fifter assy	<p>Open the front panel. Push the left and right filters to make them break away from the groove on the front case. Then remove the left and right filters one by one.</p>	 <p>Labels: Front panel, Left filter, Groove, Right filter, Front case</p>
2.Remove horizontal louver	<p>Push out the axle bush on horizontal louver, Bend the horizontal louver with hand and then separate the horizontal louver from the crank shaft of step motor to remove it.</p>	 <p>Labels: Horizontal louver, Axile bush, Location of step motor</p>
3.Remove panel and display	<p>Separate the panel rotation shaft from the groove fixing the front panel and then removes the front panel.</p> <p>Screw off the 2 screws that are locking the display board.</p>	 <p>Labels: A1 display, Screws, Panel, Front panel, Panel rotation, Groove, Screws</p>

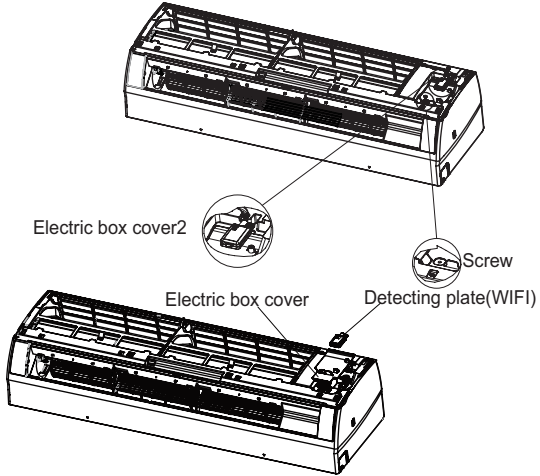
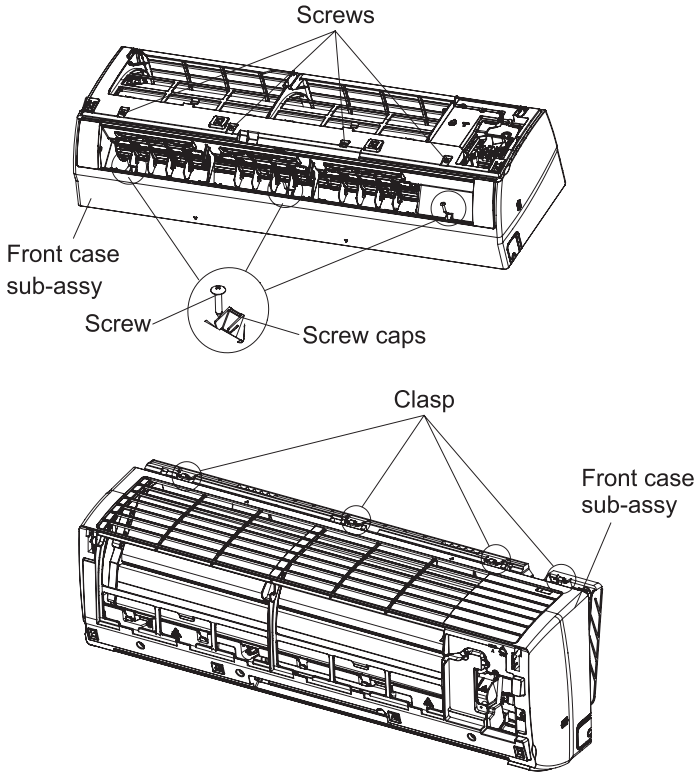
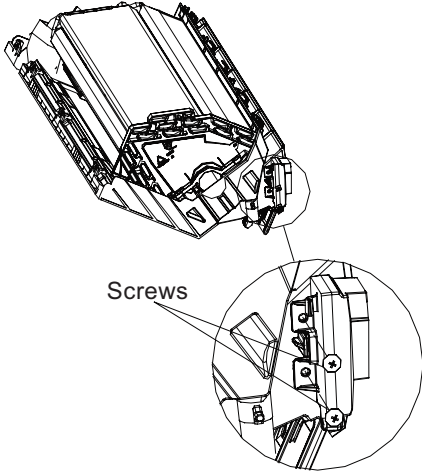
Step	Procedure	Diagram
3.Remove electric box cover 2 and detecting plate WIFI	<p>Remove the screws on the electric box cover 2 and detecting plate(WIFI), then remove the electric box cover 2 and detecting plate(WIFI).</p> <p>Note:The position of detection board(WIFI) may be different for different models.</p>	
5.Remove front case sub-assy	<p>Remove the screws fixing front case.</p> <p>Note:</p> <p>① Open the screw caps before removing the screws around the air outlet.</p> <p>② The quantity of screws fixing the front case sub-assy is different for different models.</p> <p>b Loosen the connection clasps between front case sub-assy and bottom case. Lift up the front case sub-assy and take it out.</p>	
6.Remove display	<p>Screw off the 2 screws that are locking the display board.</p>	

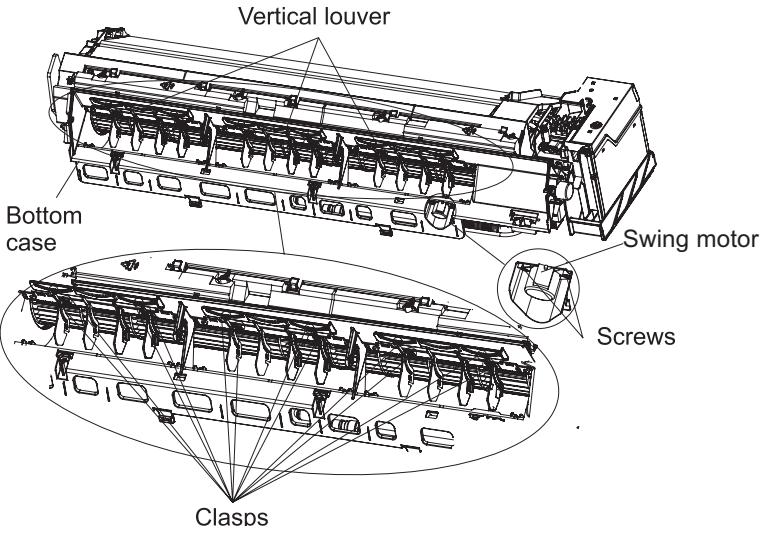
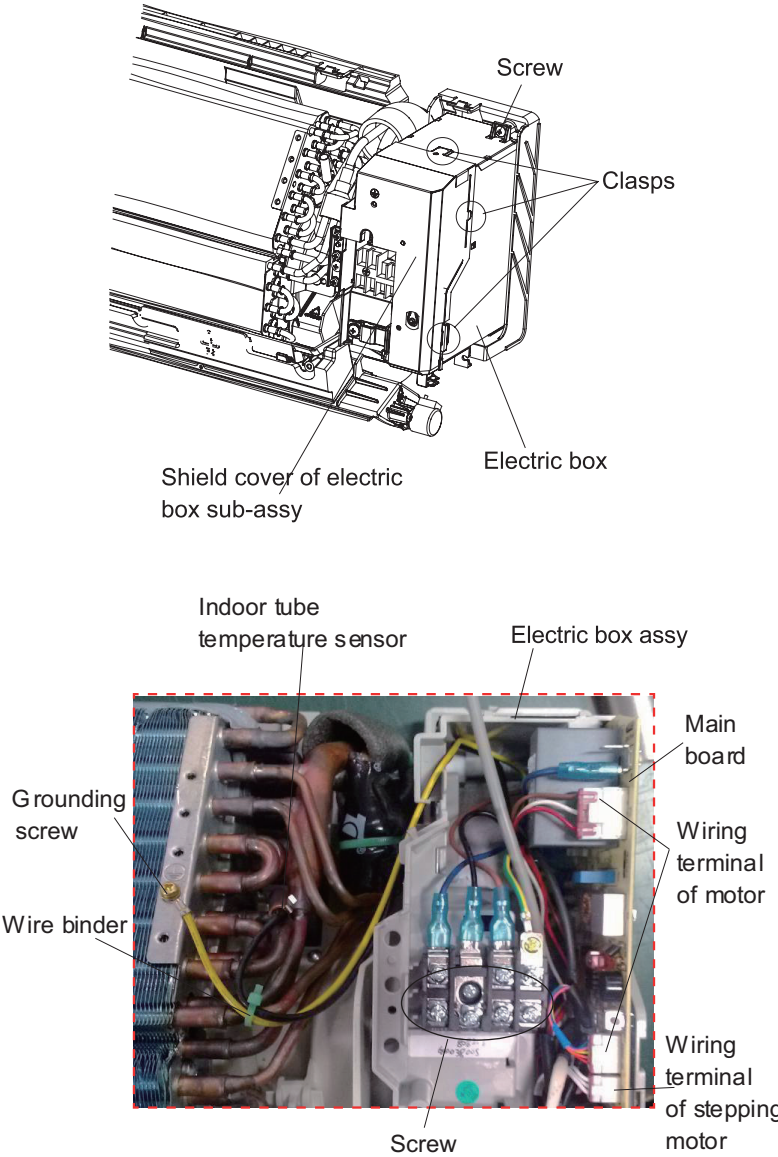
Step	Procedure
<p>7.Remove vertical louver</p> <p>a Loosen the connection clasps between vertical louver and bottom case to remove vertical louver.</p> <p>b Screw off the screws that are locking the swing motor and take the motor off.</p>	
<p>8.Remove electric box assy</p> <p>a Loosen the connection clasps between shield cover of electric box sub-assy and electric box, and then remove the shield cover of electric box sub-assy. Remove the screw fixing electric box assy.</p> <p>b</p> <ol style="list-style-type: none"> ① Cut off the wire binder and pull out the indoor tube temperature sensor. ② Screw off one grounding screw. ③ Remove the wiring terminals of motor and stepping motor. ④ Remove the electric box assy. ⑤ Screw off the screws that are locking each lead wire. 	

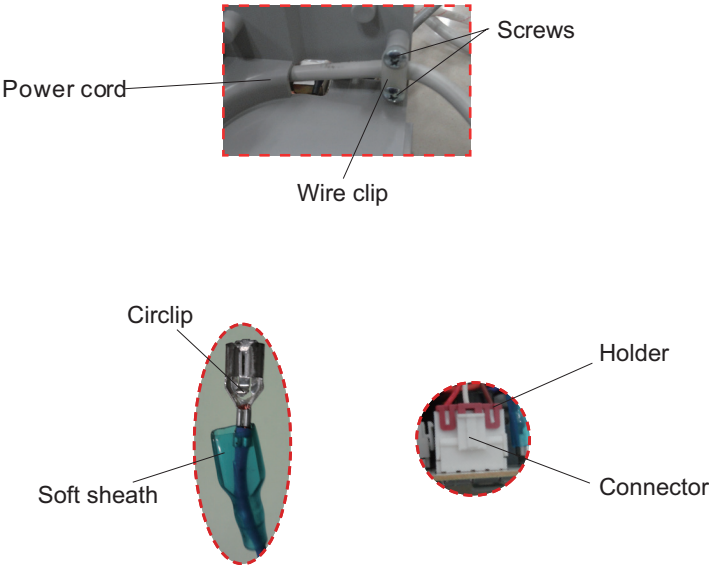
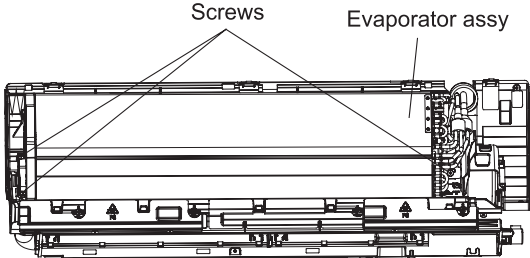
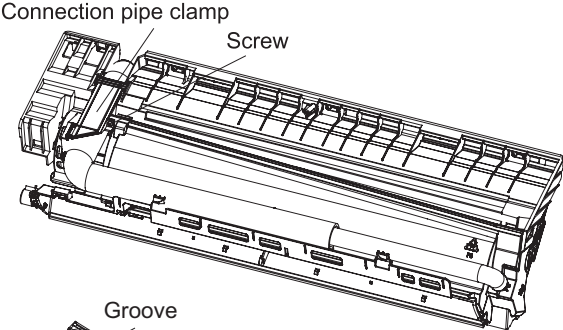
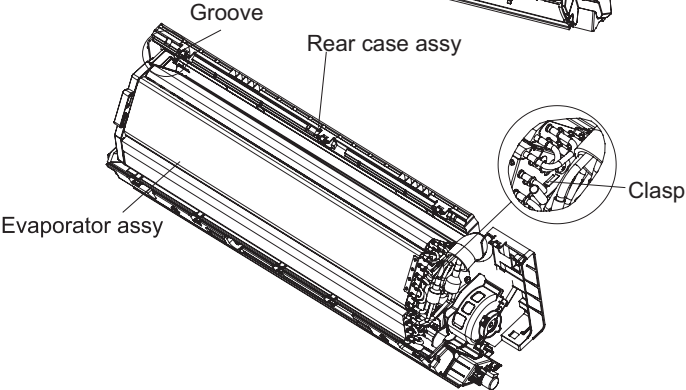
Step	Procedure	
c	<p>Rotate the electric box assy. Twist off the screws that are locking the wire clip and loosen the power cord. Remove the wiring terminal of power cord. Lift up the main board and take it off.</p> <p>Instruction: Some wiring terminal of this products is with lock catch and other devices. The pulling method is as below:</p> <p>① Remove the soft sheath for some terminals at first, hold the circlip and then pull out the terminals,</p> <p>② Pull out the holder for some terminals at first (holder is not available for some wiring terminal). hold the connector and then pull the terminal.</p>	 <p>Power cord</p> <p>Screws</p> <p>Wire clip</p> <p>Circlip</p> <p>Soft sheath</p> <p>Holder</p> <p>Connector</p>
9. Remove evaporator assy		
a	Remove 3 screws fixing evaporator assy.	 <p>Screws</p> <p>Evaporator assy</p>
b	At the back of the unit, remove the screw fixing connection pipe clamp and then remove the connection pipe clamp.	 <p>Connection pipe clamp</p> <p>Screw</p>
c	First remove the left side of evaporator from the groove on the rear case assy. Then remove the right side from the clasp on the rear case assy.	 <p>Groove</p> <p>Rear case assy</p> <p>Evaporator assy</p> <p>Clasp</p>

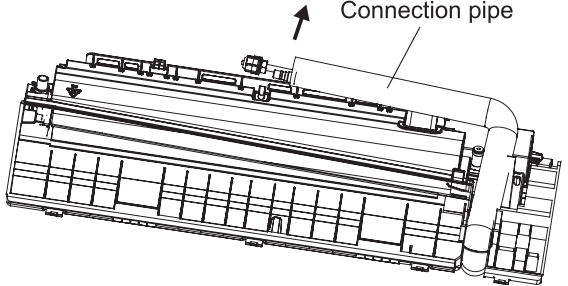
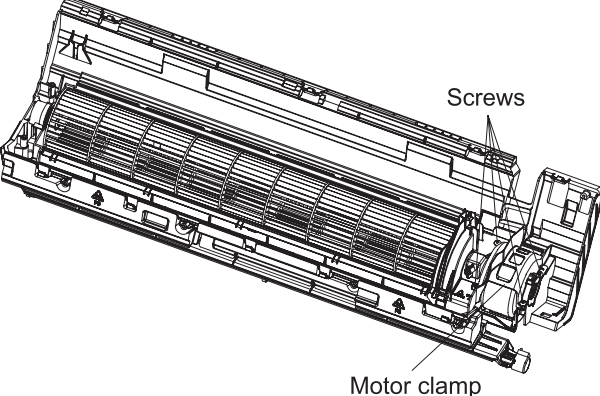
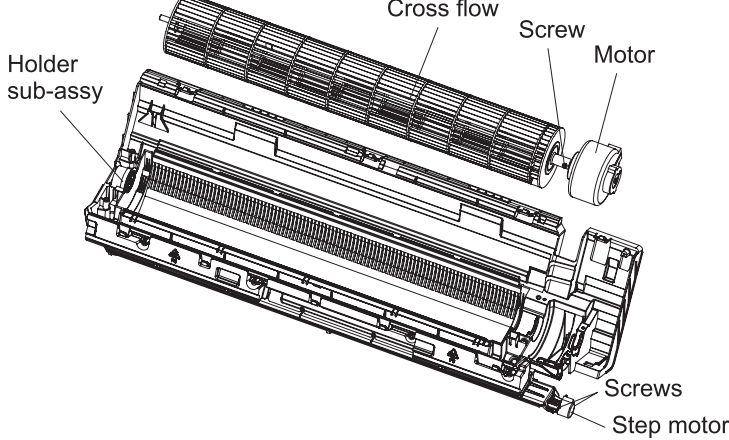
Step	Procedure	
d	Adjust the position of connction pipe on evaporator up wards to remove it.	 <p>Diagram illustrating the adjustment of the connection pipe on the evaporator. The pipe is shown being moved upwards, as indicated by the arrow and the label 'Connection pipe'.</p>
10.Remove motor and cross flow blade		
a	Remove the screws fixing motor clamp and then remove the motor clamp.	 <p>Diagram illustrating the removal of the motor clamp. The clamp is shown being detached from the motor, with labels for 'Screws' and 'Motor clamp'.</p>
b	<p>① Remove the screws at the connection place of cross flow blade and motor; lift the motor and cross flow blade upwards to remove them.</p> <p>② Remove the bearing holder sub-assy.</p> <p>③ Remove the screw fixing step motor and then remove the step motor.</p>	 <p>Diagram illustrating the removal of the cross flow blade, motor, and step motor. The components are shown being lifted upwards from the holder sub-assy, with labels for 'Holder sub-assy', 'Cross flow', 'Screw', 'Motor', 'Screws', and 'Step motor'.</p>

11.2 Removal Procedure of Outdoor Unit

GWH09QB-K6DNA1C/O

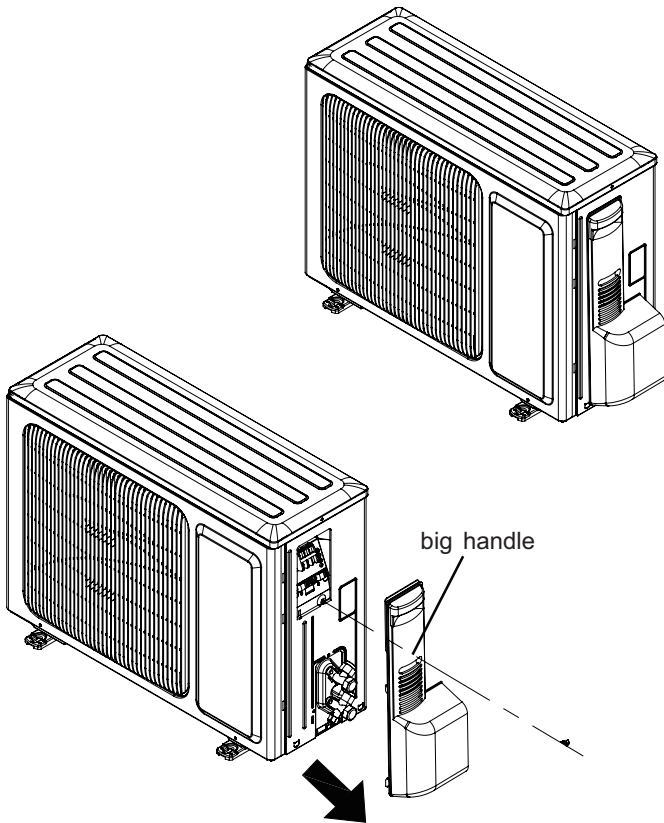
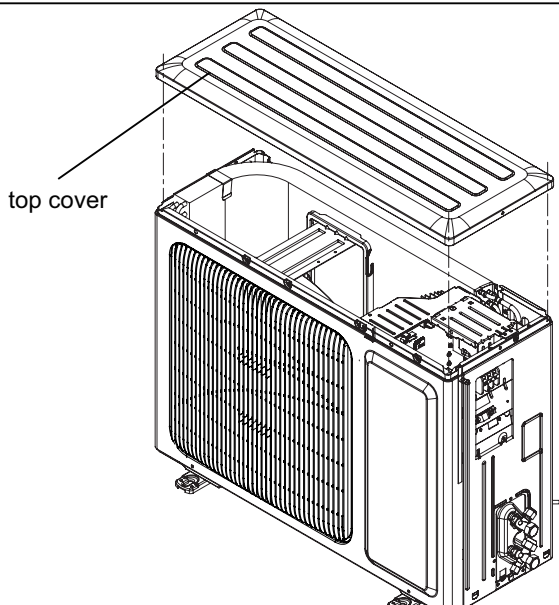
Step	Procedure
<p>1.Remove big handle</p>	<p>Before disassamble.</p> <p>Remove 1 connection screw fixing big handle and then remove the big handle.</p> 
<p>2. Remove top cover</p>	<p>Remove 3 connection screws among top cover plate, front panel and right sideplate. Then remove top cover plate.</p> 

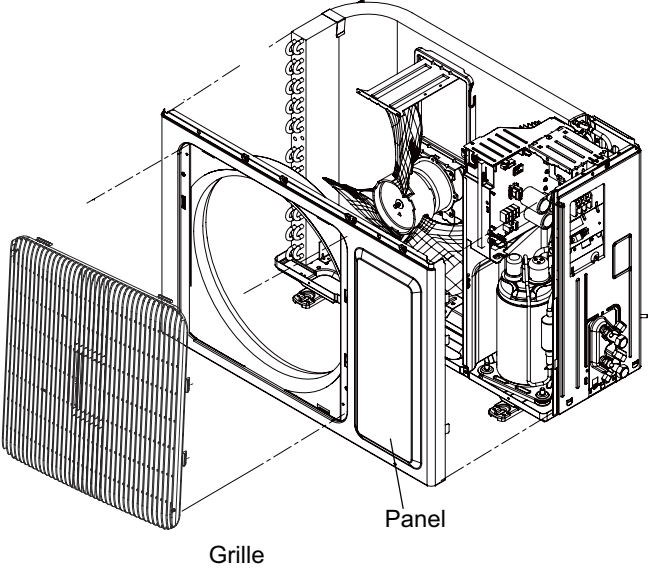
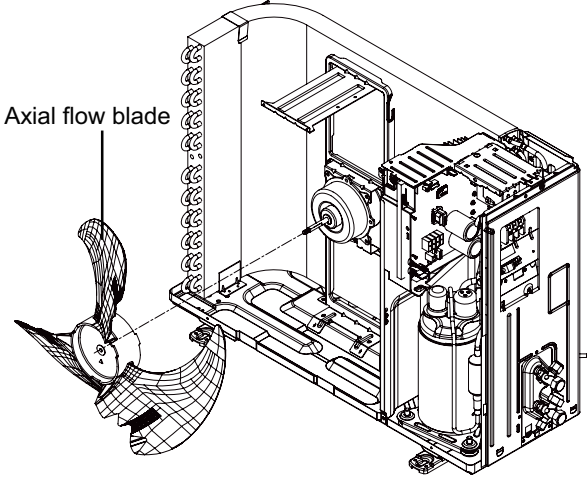
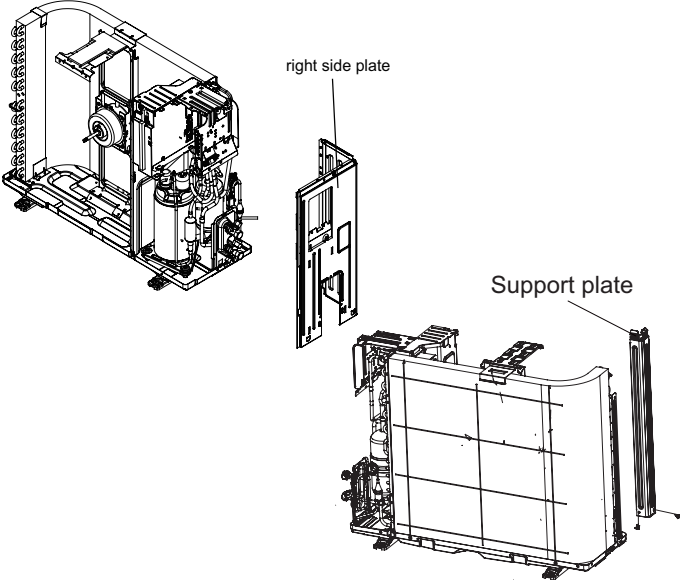
Step	Procedure
<p>3.Remove grille and front panel</p>	<p>Remove connection screws between the front grille and the front panel. Then remove the front grille. Remove connection screws connecting the front panel with the chassis and the motor support, and then remove the front panel.</p> 
<p>4.Remove axial flow blade</p>	<p>Remove the nut fixing the blade and then remove the axial flow blade.</p> 
<p>5. Remove right side plate and support plate</p>	<p>Remove connection screws connecting the right side plate with the valve support and the electric box. Then remove the right side plate.</p> <p>Remove the two screws fixing the support plate and chassis, and then remove the support plate.</p> 

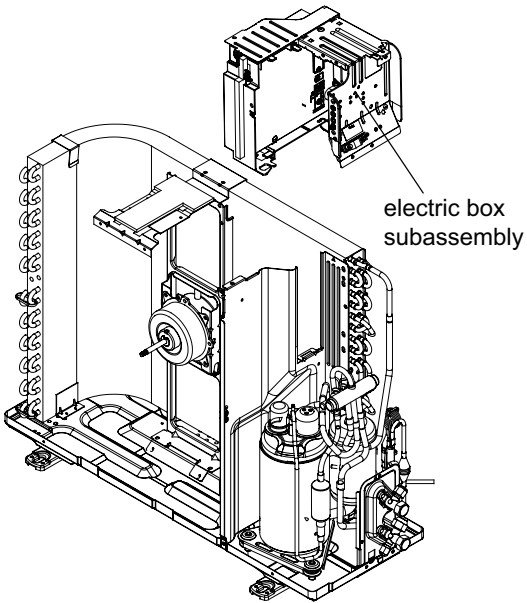
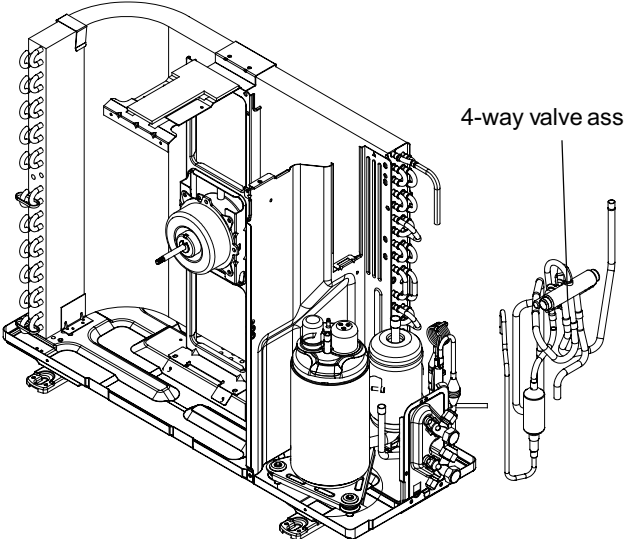
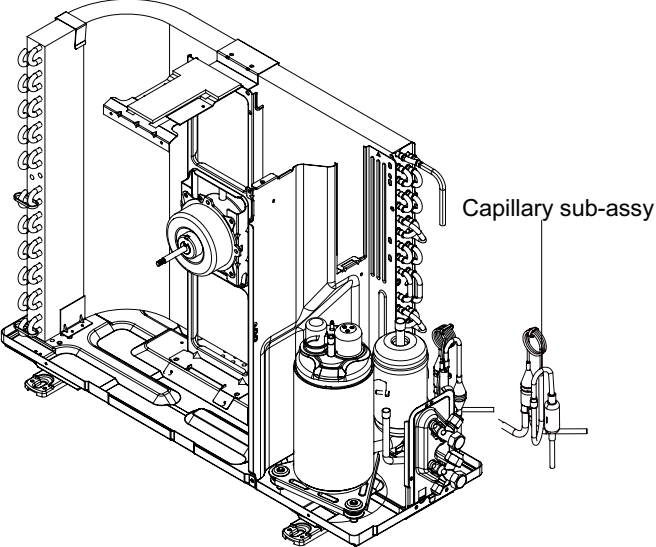
Step	Procedure
<p>6.Remove electric box assy</p>	<p>Remove the 2 screws fixing the cover of electric box. Lift to remove the cover. Loosen the wire and disconnect the terminal. Lift to remove the electric box assy.</p>  <p>electric box subassembly</p>
<p>7.Remove 4-way valve assy</p>	<p>Unscrew the fastening nut of the 4-way Valve Assy coil and remove the coil. Wrap the 4-way Valve Assy with wet cotton and unsolder the 4 weld spots connecting the 4-way Valve Assy to take it out.(Note: Refrigerant should be discharged firstly.) Welding process should be as quickly as possible and keep wrapping cotton wet all the time. Be sure not to burn out the lead-out wire of compressor.</p>  <p>4-way valve assy</p>
<p>8.Remove capillary sub-assy</p>	<p>Unsolder weld point of capillary Sub-assy, valve and outlet pipe of condensator. Then remove the capillary Sub-assy. Do not block the capillary when unsoldering it. (Note: before unsoldering, discharge refrigerants completely)</p>  <p>Capillary sub-assy</p>

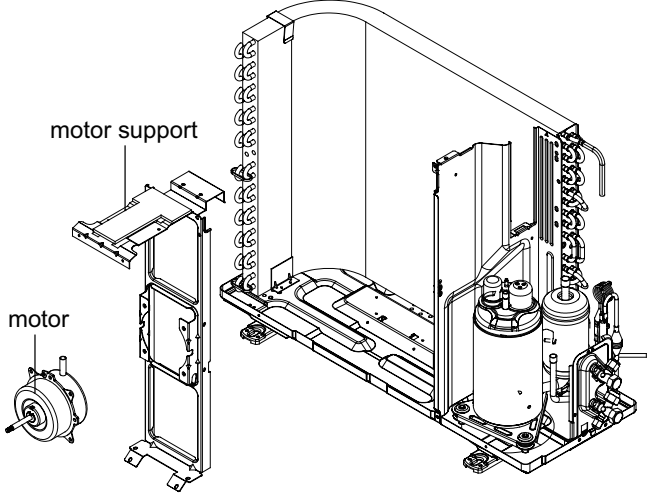
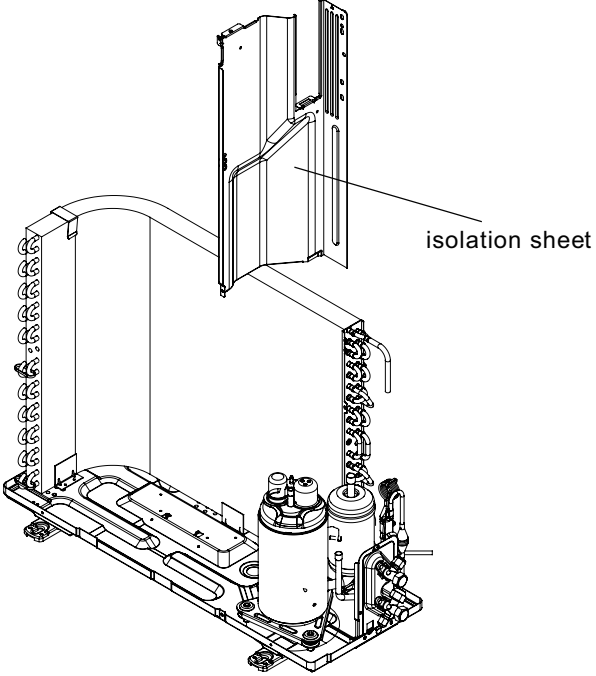
Step	Procedure
<p>9.Remove motor and motor support</p>	<p>Remove the 4 tapping screws fixing the motor. Pull out the lead-out wire and remove the motor. Remove the 2 tapping screws fixing the motor support. Lift motor support to remove it.</p> 
<p>10.Remove clapboard sub-assy</p>	<p>Loosen the screws of the Clapboard Sub-Assy . The Clapboard Sub-Assy has a hook on the lower side. Lift and pull the Clapboard Sub-Assy to remove.</p> 

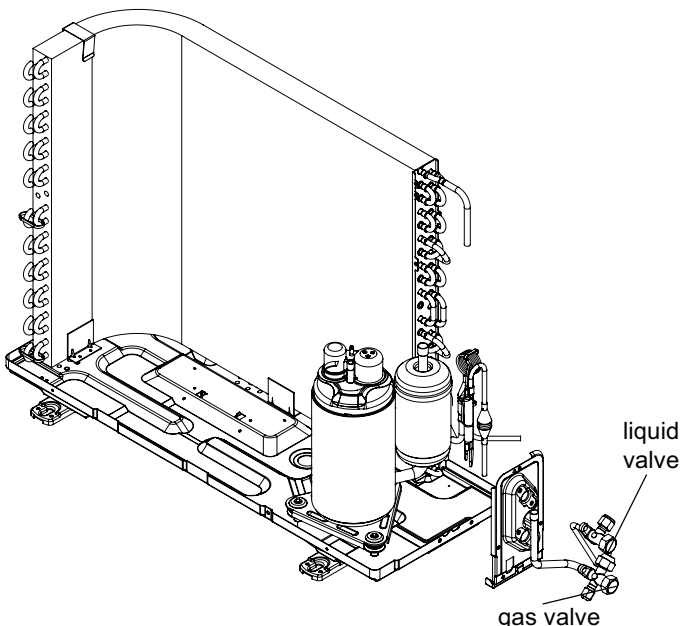
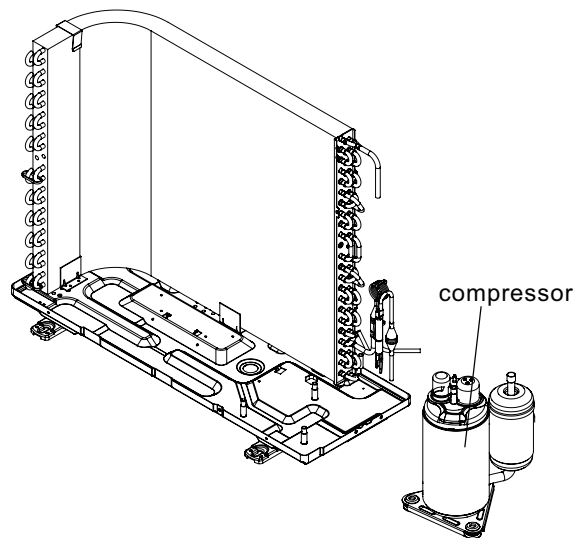
Step	Procedure	
11.Remove Compressor		
a	<p>Remove the 2 screws fixing the gas valve. Unsolder the welding spot connecting gas valve and air return pipe and remove the gas valve. (Note: it is necessary to warp the gas valve when unsoldering the welding spot.) Remove the 2 screws fixing liquid valve. Unsolder the welding spot connecting liquid valve and remove the liquid valve.</p>	
b	<p>Remove the 3 footing screws of the compressor and remove the compressor.</p>	

GWH09QB-K6DNB8I/O

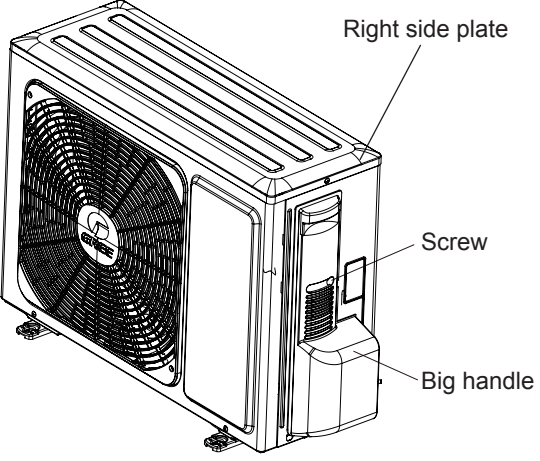
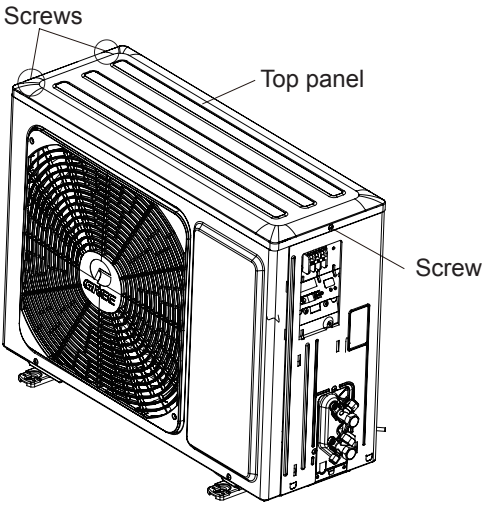
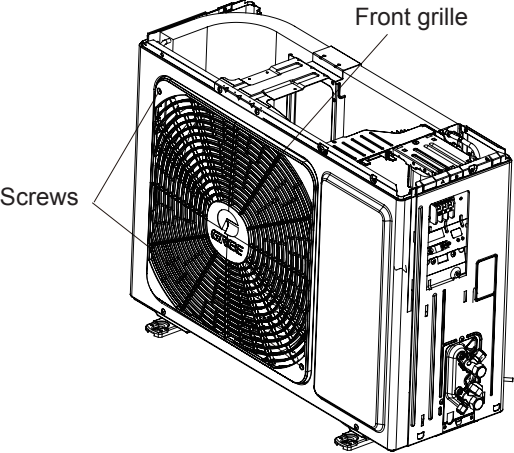
Step	Procedure	
1. Remove big handle	Remove the screw fixing big handle; slide out the big handle upwards to make the clasp of big handle separate from the groove of right side plate, and then remove the big handle.	
2. Remove top panel	Remove the screws fixing top panel and then remove the top panel.	
3. Remove front grille	Remove connection screws between the front grille and the front panel. Then remove the front grille.	

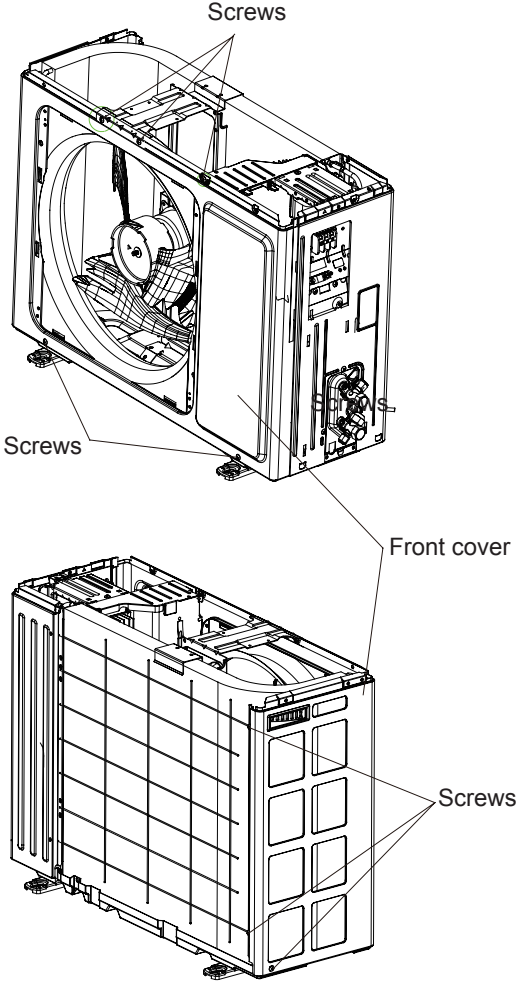
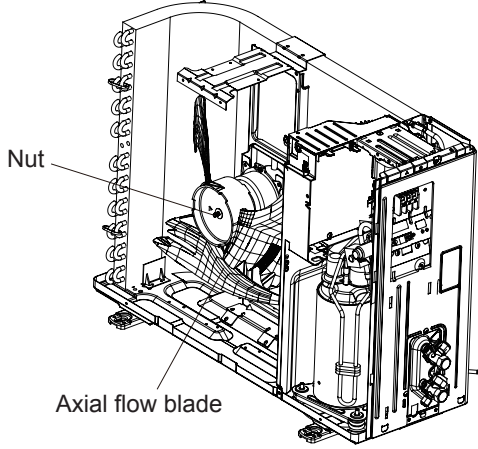
Step	Procedure
<p>4. Remove the front cover</p>	<p>Screw off the screws that are locking the front cover. Then take it off.</p> 
<p>5. Remove axial flow blade</p>	<p>Remove the nut fixing axial flow blade and then remove the axial flow blade.</p> 

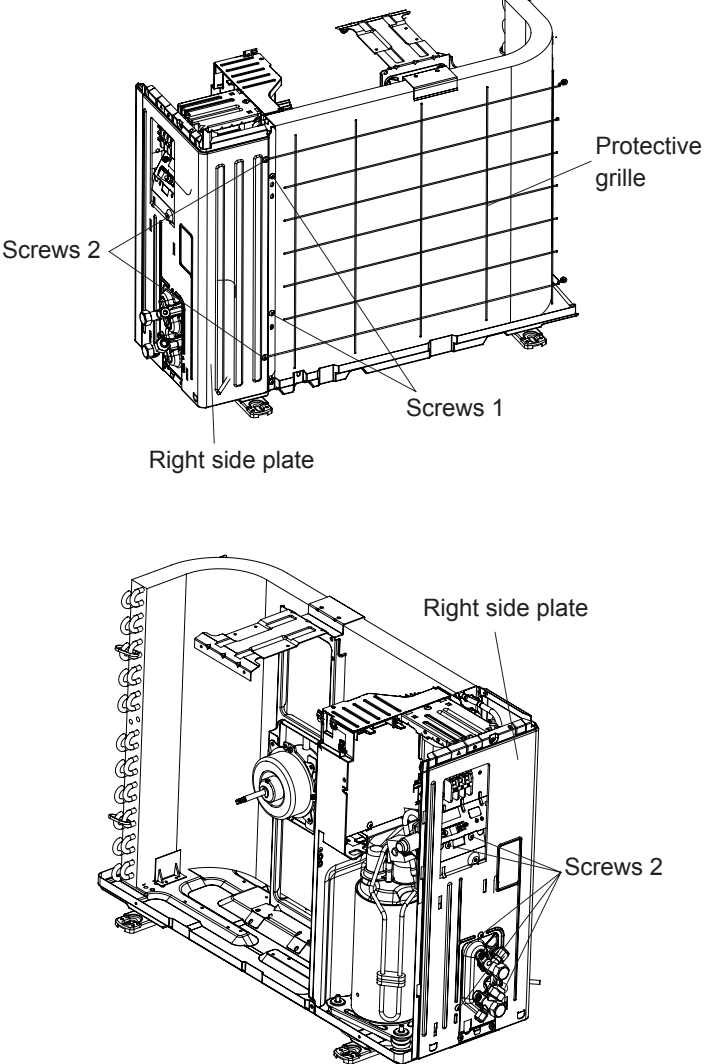
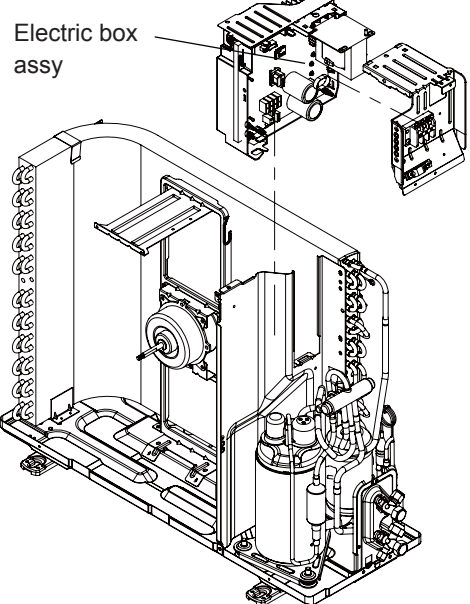
Step	Procedure
<p data-bbox="134 235 634 264">6. Remove protective grille and right side plate</p> <p data-bbox="240 395 695 482">Remove the screws 1 fixing protective grille and then remove the protective grille.</p> <p data-bbox="240 919 695 978">Remove the screws 2 fixing right side plate and then remove the right side plate.</p>	 <p data-bbox="792 497 889 526">Screws 2</p> <p data-bbox="1385 395 1498 454">Protective grille</p> <p data-bbox="1198 657 1295 685">Screws 1</p> <p data-bbox="938 705 1109 733">Right side plate</p> <p data-bbox="1214 853 1385 882">Right side plate</p> <p data-bbox="1360 1109 1458 1137">Screws 2</p>
<p data-bbox="134 1371 440 1399">7. Remove electric box assy</p> <p data-bbox="240 1487 695 1574">Remove the screws fixing electric box assy ; pull out each wiring terminal; lift the electric box assy upwards to remove it.</p> <p data-bbox="240 1618 695 1738">Note: When pulling out the wiring terminal, pay attention to loose the clasp and dont pull it so hard.</p>	 <p data-bbox="881 1437 1003 1496">Electric box assy</p>

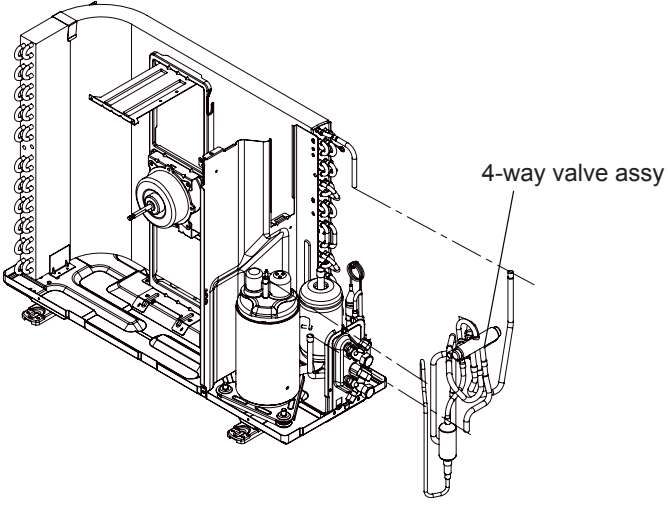
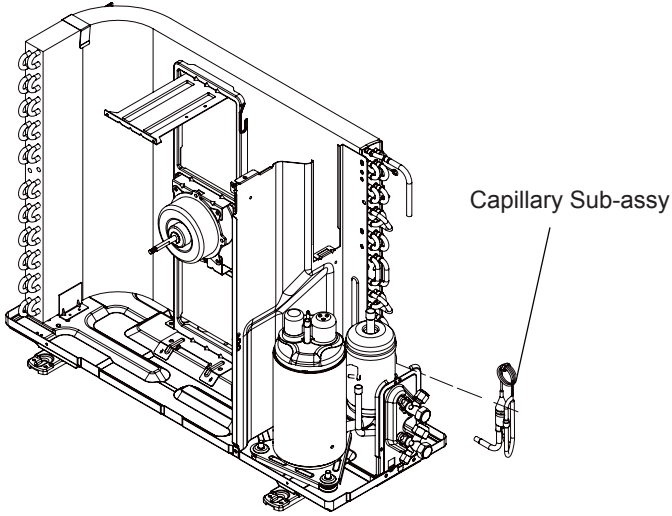
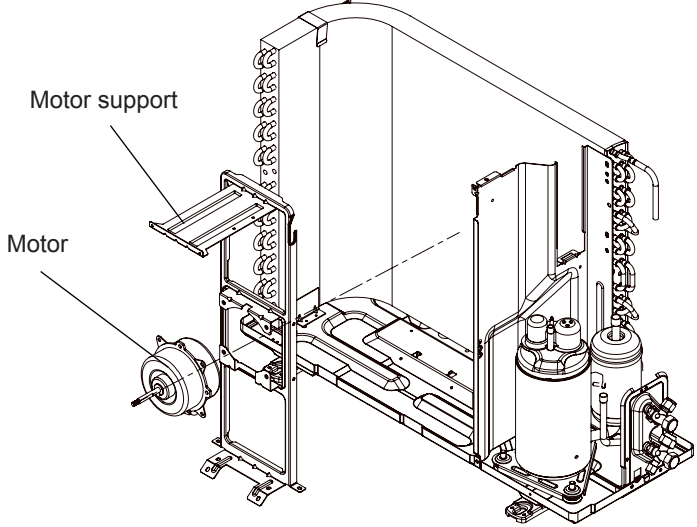
Step	Procedure
8. Remove 4-way valve assy	<p>Unsolder the spot weld of 4-way valve assy, compressor and condenser, and then remove the 4-way valve assy .</p> <p>Note: When unsoldering the spot weld, wrap the 4-way valve with wet cloth completely to avoid damaging the valve due to high temperature.</p>  <p style="text-align: right;">4-way valve assy</p>
9. Remove capillary sub-assy	<p>Unsolder weld point of capillary Sub-assy, valve and outlet pipe of condensator. Then remove the capillary Sub-assy. Do not block the capillary when unsoldering it. (Note: before unsoldering, discharge refrigerants completely)</p>  <p style="text-align: right;">Capillary Sub-assy</p>
10. Remove motor and motor support	<p>Remove the 4 tapping screws fixing the motor. Pull out the lead-out wire and remove the motor. Remove the 2 tapping screws fixing the motor support. Lift motor support to re-move it.</p>  <p style="text-align: right;">Motor support</p> <p style="text-align: right;">Motor</p>

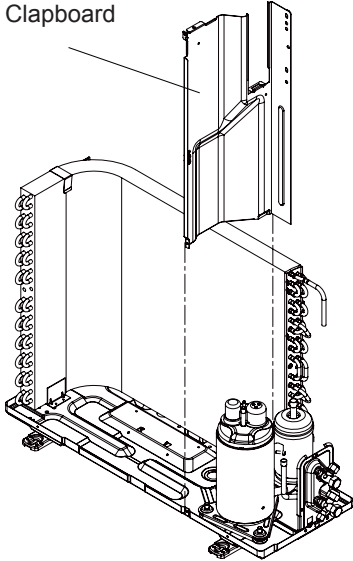
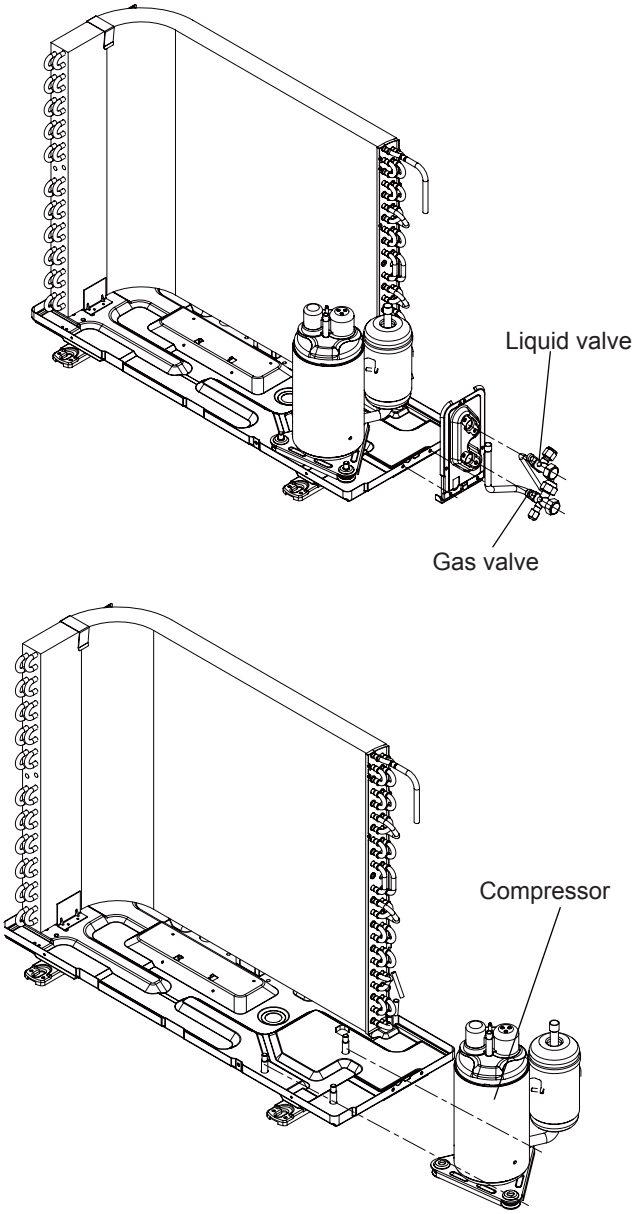
Step	Procedure
<p>11. Remove clapboard sub-assy</p>	<p>Loosen the screws of the Clapboard Sub-Assy . The Clapboard Sub-Assy has a hook on the lower side. Lift and pull the Clapboard Sub-Assy to remove.</p> 
<p>12. Remove Compressor</p>	<p>Remove the 2 screws fixing the gas valve. Unsolder the welding spot connecting gas valve and air return pipe and remove the gas valve. (Note: it is necessary to warp the gas valve when unsoldering the welding spot.) Remove the 2 screws fixing liquid valve. Unsolder the welding spot connecting liquid valve and remove the liquid valve.</p> <p>Remove the 3 footing screws of the compressor and remove the compressor.</p> 

GWH12QC-K6DNA1C/O GWH12QB-K6DNB8I/O GWH18AAD-K6DNA1B/O

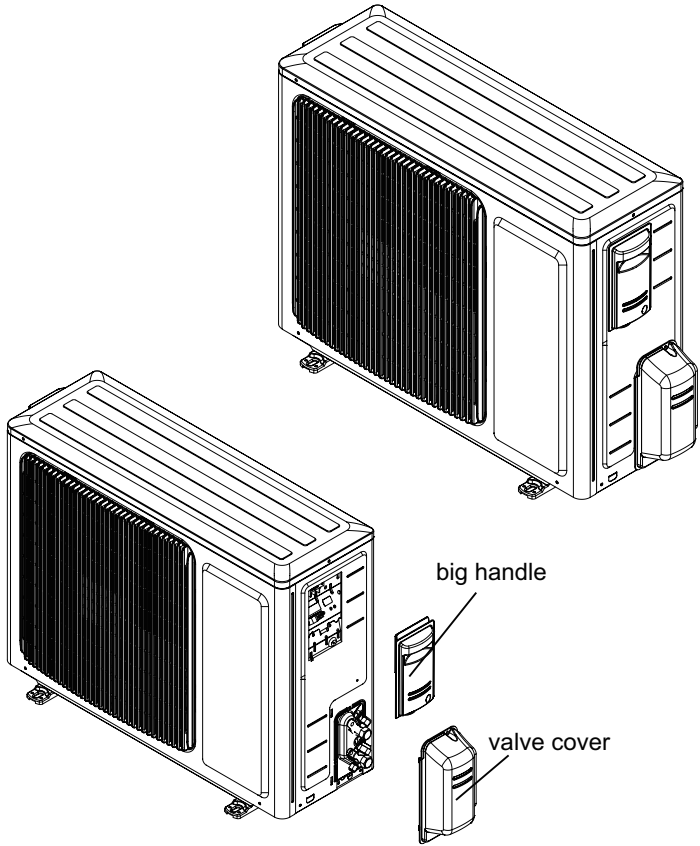
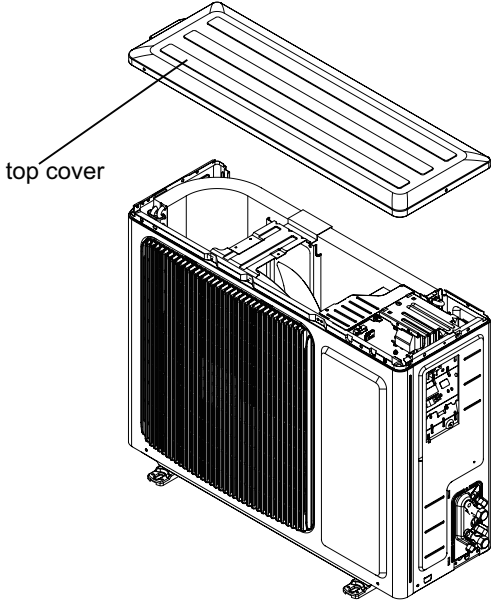
Steps	Procedure
<p>1.Remove big handle</p> <p>Before disassamble.</p> <p>Remove the screws fixing big handle、 valve cover and then remove them.</p>	
<p>2. Remove top cover</p> <p>Remove the screws fixing top panel and then remove the top panel.</p>	

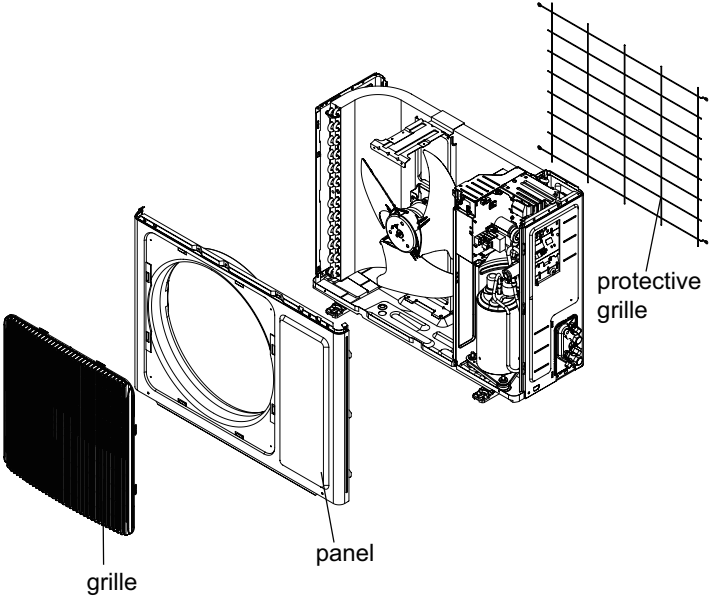
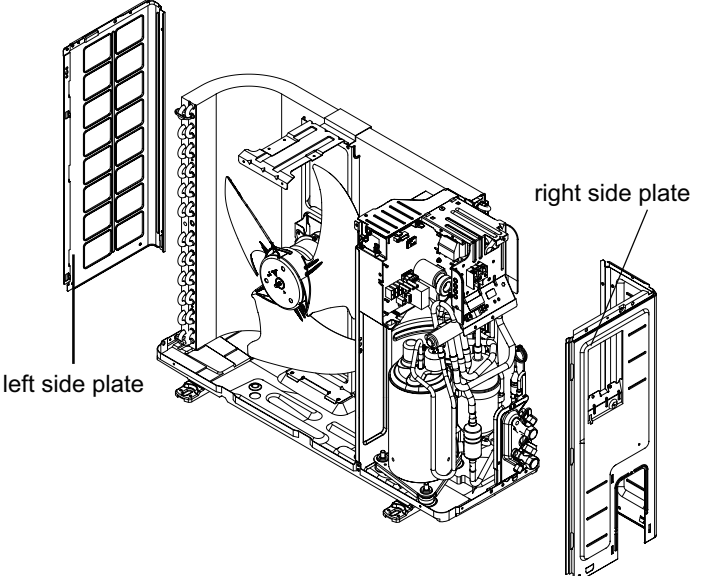
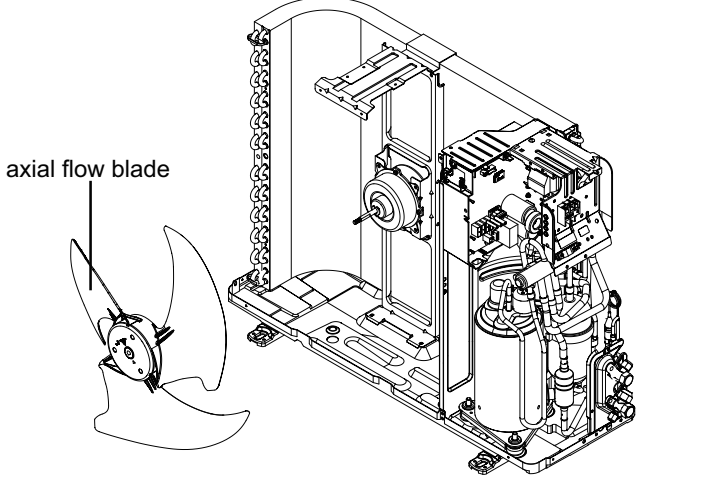
Step	Procedure
<p>3.Remove grille 、 protective grille and front panel</p>	<p>Remove connection screws between the front grille and the front panel. Then remove the front grille. Remove connection screws connecting the front panel with the chassis and the motor support, and then remove the front panel. Remove the screws fixing protective grille and then remove the protective grille.</p>  <p>The diagram illustrates the disassembly process for step 3. It shows a perspective view of the unit's internal components, including the motor, fan, and various support structures. A separate view shows the front panel and grille being removed. Labels include 'grille', 'panel', and 'protective grille'.</p>
<p>4.Remove right side plate、 left side plate</p>	<p>Remove the screws fixing right side plate、 left side plate and then remove them.</p>  <p>The diagram illustrates the disassembly process for step 4. It shows a perspective view of the unit's internal components. Two separate views show the left side plate and right side plate being removed from the chassis. Labels include 'left side plate' and 'right side plate'.</p>
<p>5.Remove axial flow blade</p>	<p>Remove the nut fixing the blade and then remove the axial flow blade.</p>  <p>The diagram illustrates the disassembly process for step 5. It shows a perspective view of the unit's internal components. A separate view shows the axial flow blade being removed from the motor assembly. Label includes 'axial flow blade'.</p>

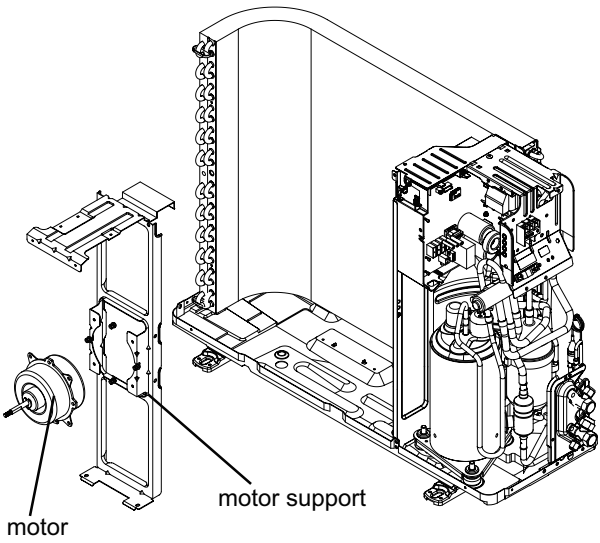
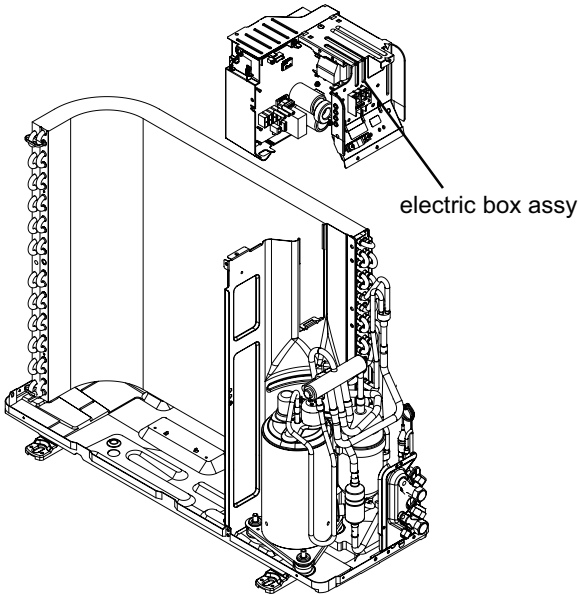
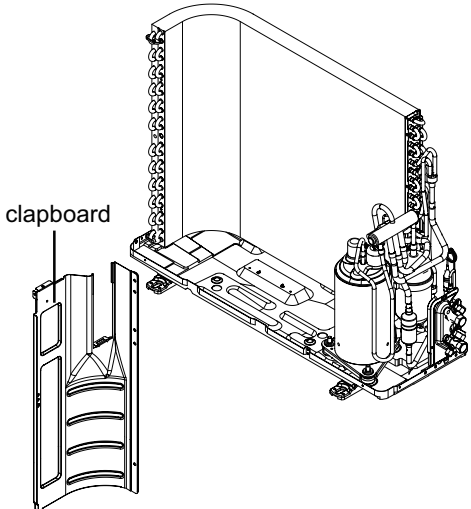
Step	Procedure
<p>6.Remove motor and motor support</p>	<p>Remove the screws fixing motor and then remove the motor. Remove the screws fixing motor support and then remove the motor support.</p> 
<p>7.Remove electric box assy</p>	<p>Remove the screws fixing electric box assy; cut off the tieline; pull out each wiring terminal; lift the electric box assy upwards to remove it. Note: When pulling out the wiring terminal, pay attention to loose the clasp and don't pull it so hard.</p> 
<p>8.Remove clapboard</p>	<p>Remove the screws fixing clapboard and then remove the clapboard.</p> 

Step	Procedure
<p>9.Remove 4-way valve assy and capillary sub-assy</p>	<p>Unsolder the welding joints connecting the 4-way valve assy with capillary sub-assy, compressor and condenser; remove the 4-way valve.</p> <p>Note: Before unsoldering the welding joint, wrap the 4-way valve with a wet cloth completely to avoid damage to the valve caused by high temperature.</p> <p>Unsolder weld point of capillary Sub-assy, valve and outlet pipe of condensator. Then remove the capillary Sub-assy. Do not block the capillary when unsoldering it. (Note: before unsoldering, discharge refrigerants completely)</p>
<p>10.Remove liquid valve and gas valve</p>	<p>Unsolder the welding joint connecting the valve with capillary and condenser; unsolder the welding joint connecting the gas valve and air-return pipe; remove the 2 screws fixing the gas valve to remove the gas valve.</p> <p>Unsolder the welding joint connecting the liquid valve and Y-shaped pipe; remove the 2 screws fixing the liquid valve to remove the liquid valve.</p> <p>Note: Before unsoldering the welding joint, wrap the gas valve with a wet cloth completely to avoid damage to the valve caused by high temperature.</p>
<p>11.Remove compressor</p>	<p>Remove the 3 footing screws of the compressor and remove the compressor.</p> <p>Remove the screws fixing valve support and then remove the valve support.</p>

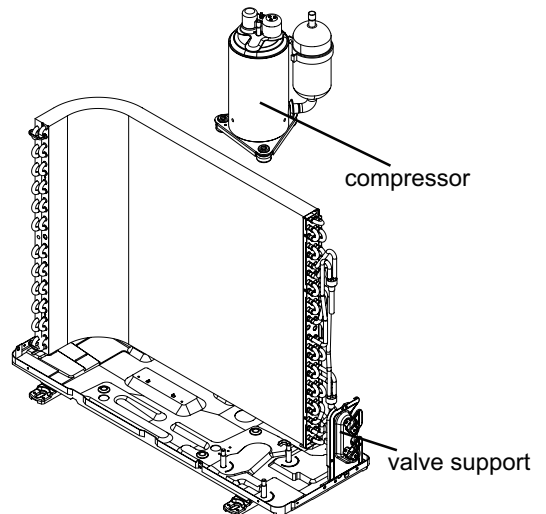
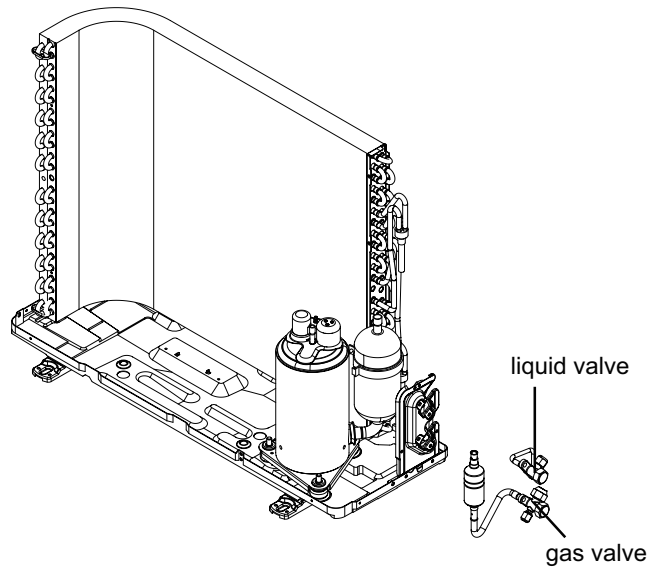
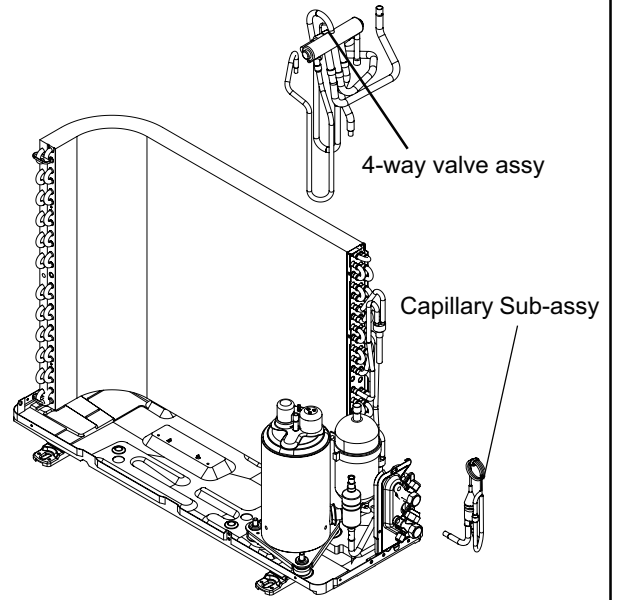

Warning: Be sure to wait for a minimum of 20 minutes after turning off all power supplies and discharge the refrigerant completely before removal.

GWH18QD-K6DNA1C/O

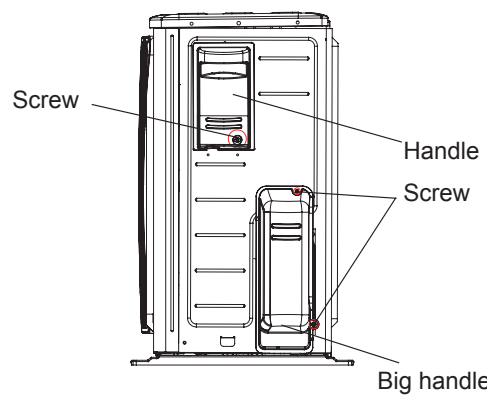
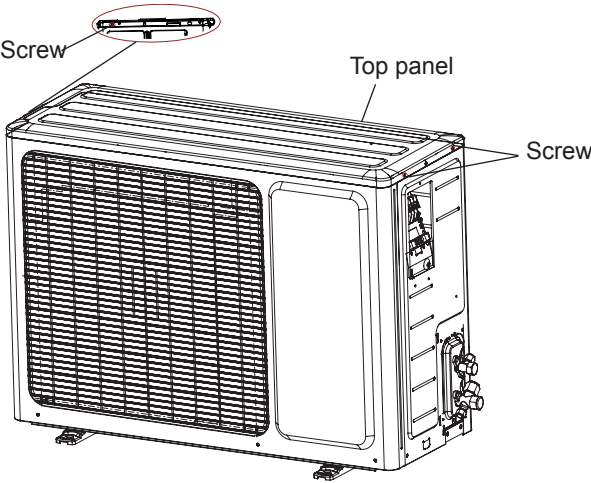
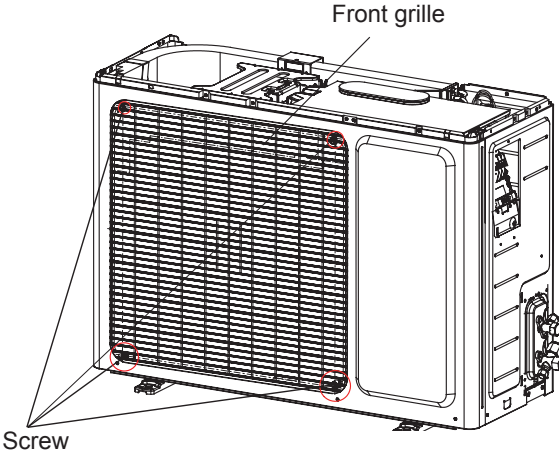
Step	Procedure
<p>1. Remove big handle</p>	<p>Remove the screw fixing big handle; slide out the big handle down wards to make the clasp of big handle separate from the groove of right side plate, and then remove the big handle.</p> 
<p>2. Remove top panel</p>	<p>Remove the screws fixing top panel and then remove the top panel.</p> 
<p>3. Remove front grille</p>	<p>Remove connection screws between the front grille and the front panel. Then remove the front grille.</p> 

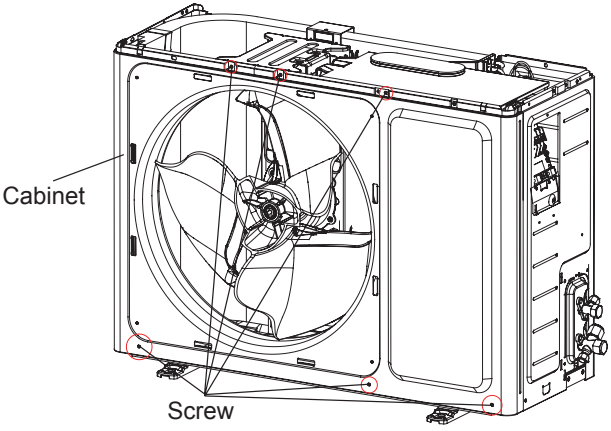
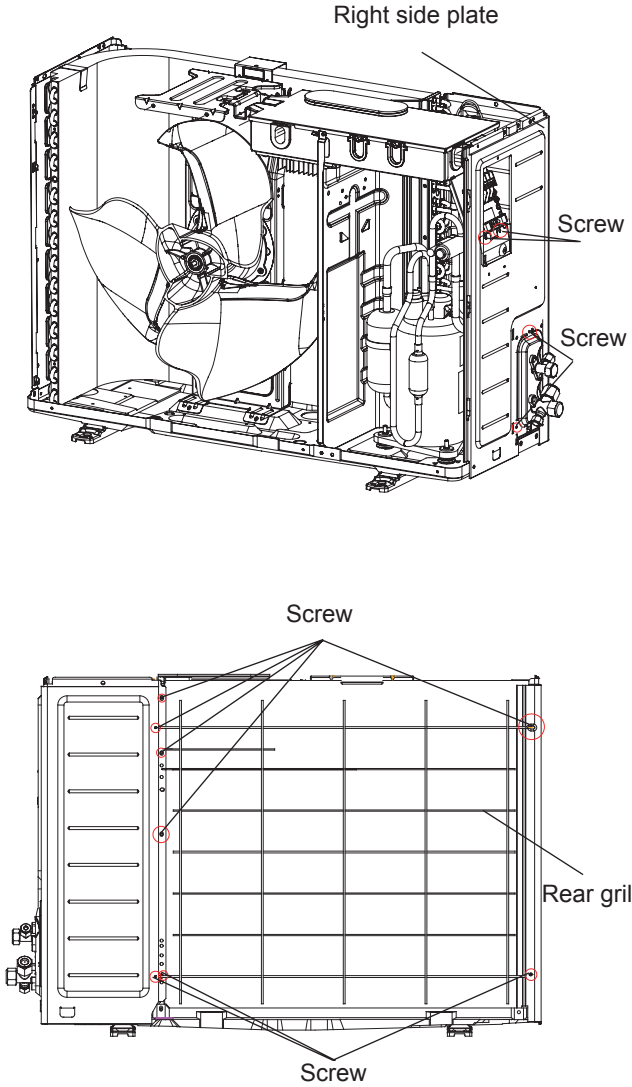
Step	Procedure	
4. Remove cabinet	<p data-bbox="235 307 699 362">Remove the screws fixing cabinet and then remove the cabinet.</p> 	
5. Remove right side plate and rear grill	<p data-bbox="235 843 678 904">Remove the screws fixing right side plate and then remove the right side plate.</p> <p data-bbox="235 1362 678 1423">Remove the screws and then remove the grille.</p> 	

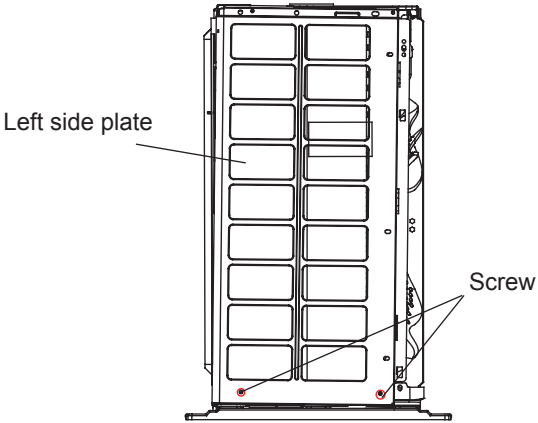
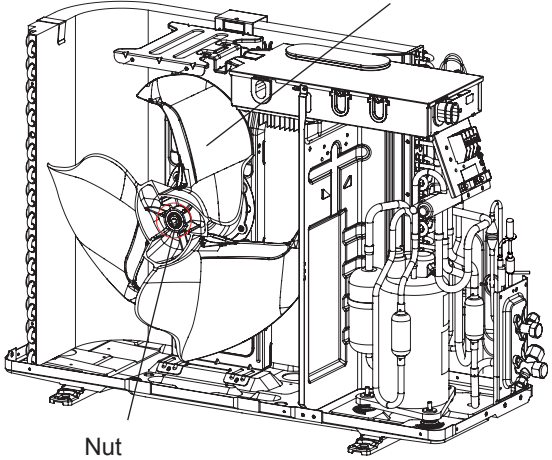
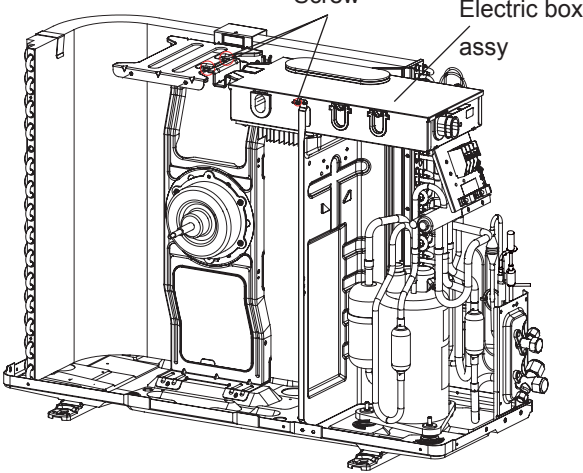
Step	Procedure	Procedure
6. Remove left side plate	Remove the screws fixing left side plate and then remove the left side plate.	 <p>The diagram shows a vertical rectangular panel with a grid of eight rectangular cutouts. A line points from the label 'Left side plate' to the panel. Another line points from the label 'Screw' to a screw on the right edge of the panel.</p>
7. Remove axial flow blade	Remove the nut fixing axial flow blade and then remove the axial flow blade.	 <p>The diagram shows a complex mechanical assembly. A large, curved blade is attached to a central hub. A line points from the label 'Axial flow blade' to the blade. Another line points from the label 'Nut' to a nut on the hub.</p>
8. Remove electric box assy	<p>Remove the screws fixing electric box assy ; pull out each wiring terminal; lift the electric box assy upwards to remove it.</p> <p>Note: When pulling out the wiring terminal, pay attention to loose the clasp and dont pull it so hard.</p>	 <p>The diagram shows the same complex mechanical assembly as in step 7, but with the top section removed. A line points from the label 'Screw' to a screw on the top edge of the remaining structure. Another line points from the label 'Electric box assy' to the removed top section.</p>

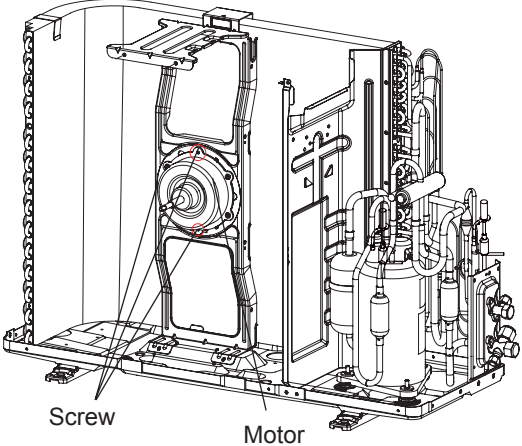
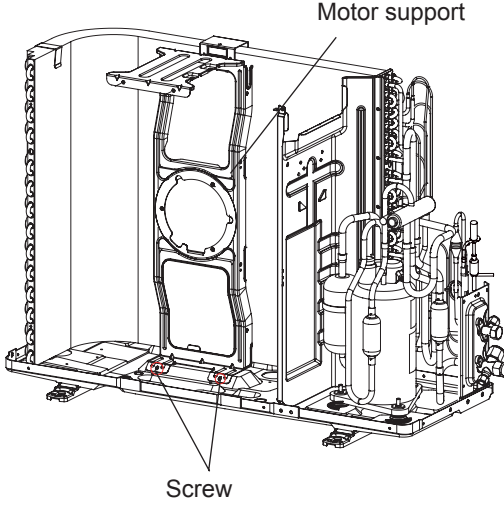
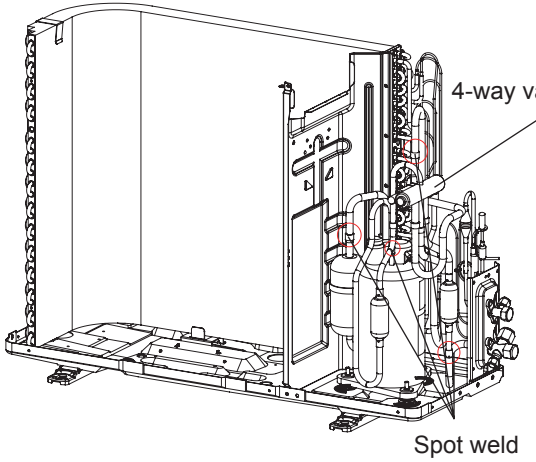
Step	Procedure
<p>9.Remove motor</p>	<p>Remove the screws fixing motor and then remove the motor.</p> 
<p>10.Remove motor support</p>	<p>Remove the screws fixing motor support and then remove the motor support.</p> 
<p>11.Remove 4-way valve assy</p>	<p>Unsolder the spot weld of 4-way valve assy, compressor and condenser, and then remove the 4-way valve assy . Note: When unsoldering the spot weld, wrap the 4-way valve with wet cloth completely to avoid damaging the valve due to high temperature.</p> 

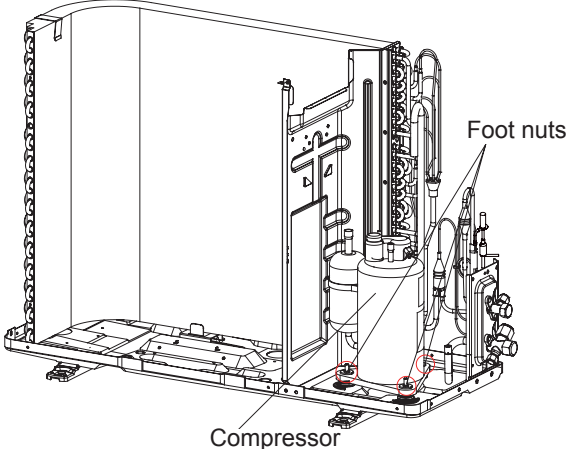
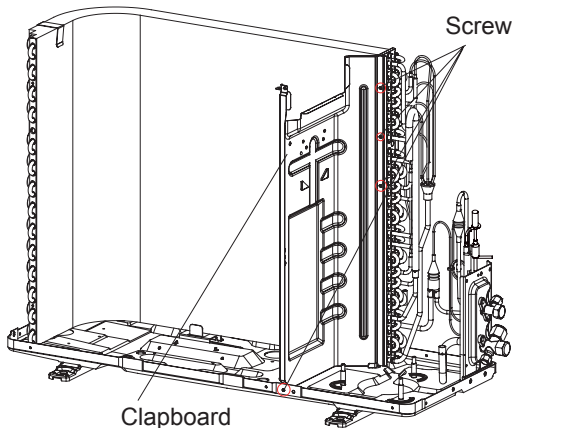
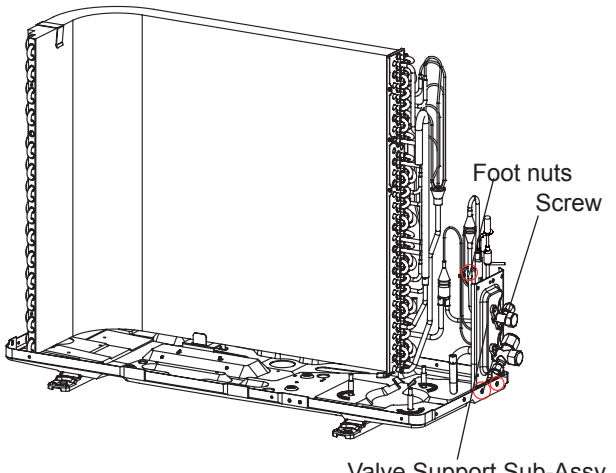
Step	Procedure	
12. Remove compressor	<p>Remove 3 foot nuts on compressor, and then remove the compressor.</p> <p>Note: Protect the ports of discharge pipe and suction pipe to avoid foreign objects to enter it.</p>	 <p>The diagram shows a side view of the compressor assembly within a cabinet. Three foot nuts are indicated by red circles and arrows, located at the base of the compressor. The compressor itself is labeled with a line pointing to its main body.</p>
13. Remove clapboard	<p>Remove the screws fixing clapboard and then remove the clapboard.</p>	 <p>The diagram shows the clapboard assembly. A screw is indicated by a red circle and arrow, located where the clapboard is secured to the frame. The clapboard itself is labeled with a line pointing to its vertical surface.</p>
14. Remove Valve support sub-assy	<p>Screw off the screws that are locking the valve support sub-assy. Then remove it.</p>	 <p>The diagram shows the valve support sub-assembly. Two foot nuts are indicated by red circles and arrows at the base. A screw is also indicated by a red circle and arrow, located on the side of the sub-assembly. The entire sub-assembly is labeled with a line pointing to its base.</p>

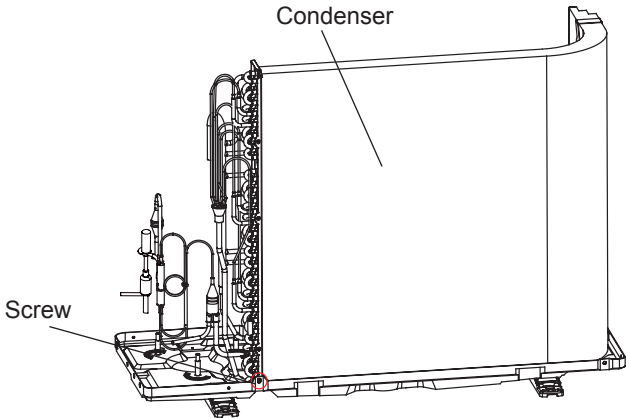
Step	Procedure
15. Remove condenser	
	<p data-bbox="191 334 630 395">Remove one screw fixing the condenser, then remove the condenser.</p> 

Appendix:

Appendix 1: Reference Sheet of Celsius and Fahrenheit

Conversion formula for Fahrenheit degree and Celsius degree: $T_f = T_c \times 1.8 + 32$

Set temperature

Fahrenheit display temperature (°F)	Fahrenheit (°F)	Celsius (°C)	Fahrenheit display temperature (°F)	Fahrenheit (°F)	Celsius (°C)	Fahrenheit display temperature (°F)	Fahrenheit (°F)	Celsius (°C)
61	60.8	16	69/70	69.8	21	78/79	78.8	26
62/63	62.6	17	71/72	71.6	22	80/81	80.6	27
64/65	64.4	18	73/74	73.4	23	82/83	82.4	28
66/67	66.2	19	75/76	75.2	24	84/85	84.2	29
68	68	20	77	77	25	86	86	30

Ambient temperature

Fahrenheit display temperature (°F)	Fahrenheit (°F)	Celsius (°C)	Fahrenheit display temperature (°F)	Fahrenheit (°F)	Celsius (°C)	Fahrenheit display temperature (°F)	Fahrenheit (°F)	Celsius (°C)
32/33	32	0	55/56	55.4	13	79/80	78.8	26
34/35	33.8	1	57/58	57.2	14	81	80.6	27
36	35.6	2	59/60	59	15	82/83	82.4	28
37/38	37.4	3	61/62	60.8	16	84/85	84.2	29
39/40	39.2	4	63	62.6	17	86/87	86	30
41/42	41	5	64/65	64.4	18	88/89	87.8	31
43/44	42.8	6	66/67	66.2	19	90	89.6	32
45	44.6	7	68/69	68	20	91/92	91.4	33
46/47	46.4	8	70/71	69.8	21	93/94	93.2	34
48/49	48.2	9	72	71.6	22	95/96	95	35
50/51	50	10	73/74	73.4	23	97/98	96.8	36
52/53	51.8	11	75/76	75.2	24	99	98.6	37
54	53.6	12	77/78	77	25			

Appendix 2: Configuration of Connection Pipe

1. Standard length of connection pipe

- 5m, 7.5m, 8m.

2. Min length of connection pipe For the unit with standard connection pipe of 5m, there is no limitation for them in length of connection pipe. For the unit with standard connection pipe of 7.5m and 8m, the min length of connection pipe is 3m.

3. Max length of connection pipe (More details please refer to the specifications)

4. The additional refrigerant oil and refrigerant charging required after prolonging connection pipe

- After the length of connection pipe is prolonged for 10m at the basis of standard length, you should add 5ml of refrigerant oil for each additional 5m of connection pipe.

- The calculation method of additional refrigerant charging amount (on the basis of liquid pipe):

- Basing on the length of standard pipe, add refrigerant according to the requirement as shown in the table. The additional refrigerant charging amount per meter is different according to the diameter of liquid pipe. See Sheet 2.

- Additional refrigerant charging amount = prolonged length of liquid pipe X additional refrigerant charging amount per meter

Additional refrigerant charging amount for R32				
Diameter of connection pipe		Indoor unit throttl	Outdoor unit throttle	
Liquid pipe	Gas pipe	Cooling only, cooling and heating(g / m)	Cooling only(g / m)	Cooling and heating(g / m)
Φ6	Φ9.5 or Φ12	16	12	16
Φ6 or Φ9.5	Φ16 or Φ19	40	12	40
Φ12	Φ19 or Φ22.2	80	24	96
Φ16	Φ25.4 or Φ31.8	136	48	96
Φ19	/	200	200	200
Φ22.2	/	280	280	280

Note: The additional refrigerant charging amount in Sheet 2 is recommended value, not compulsory.

Appendix 3: Pipe Expanding Method

⚠ Note:

Improper pipe expanding is the main cause of refrigerant leakage. Please expand the pipe according to the following steps:

A: Cut the pipe

- Confirm the pipe length according to the distance of indoor unit and outdoor unit.
- Cut the required pipe with pipe cutter.

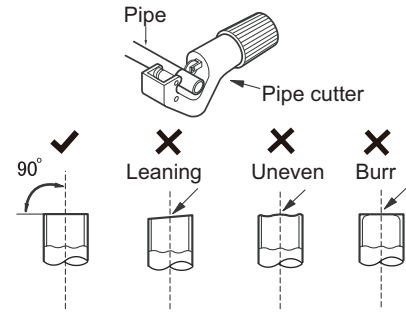

B: Remove the burrs

- Remove the burrs with shaper and prevent the burrs from getting into the pipe.

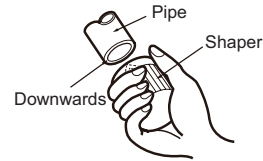

C: Put on suitable insulating pipe

D: Put on the union nut

- Remove the union nut on the indoor connection pipe and outdoor valve; install the union nut on the pipe.

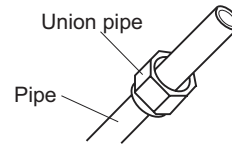

E: Expand the port

- Expand the port with expander.

⚠ Note:

- "A" is different according to the diameter, please refer to the sheet below:

Outer diameter(mm)	A(mm)	
	Max	Min
Φ6 - 6.35 (1/4")	1.3	0.7
Φ9.52 (3/8")	1.6	1.0
Φ12 - 12.70 (1/2")	1.8	1.0
Φ16 - 15.88 (5/8")	2.4	2.2

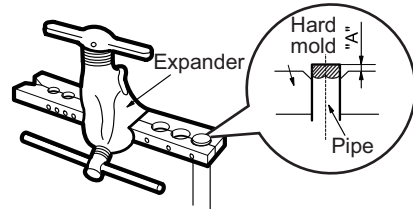

F: Inspection

- Check the quality of expanding port. If there is any blemish, expand the port again according to the steps above.

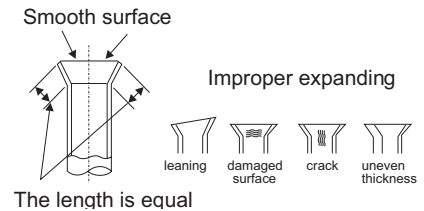

Appendix 4: List of Resistance for Temperature Sensor

Resistance Table of Ambient Temperature Sensor for Indoor and Outdoor (15K)

Temp(°C)	Resistance(kΩ)	Temp(°C)	Resistance(kΩ)	Temp(°C)	Resistance(kΩ)	Temp(°C)	Resistance(kΩ)
-19	138.1	20	18.75	59	3.848	98	1.071
-18	128.6	21	17.93	60	3.711	99	1.039
-17	121.6	22	17.14	61	3.579	100	1.009
-16	115	23	16.39	62	3.454	101	0.98
-15	108.7	24	15.68	63	3.333	102	0.952
-14	102.9	25	15	64	3.217	103	0.925
-13	97.4	26	14.36	65	3.105	104	0.898
-12	92.22	27	13.74	66	2.998	105	0.873
-11	87.35	28	13.16	67	2.896	106	0.848
-10	82.75	29	12.6	68	2.797	107	0.825
-9	78.43	30	12.07	69	2.702	108	0.802
-8	74.35	31	11.57	70	2.611	109	0.779
-7	70.5	32	11.09	71	2.523	110	0.758
-6	66.88	33	10.63	72	2.439	111	0.737
-5	63.46	34	10.2	73	2.358	112	0.717
-4	60.23	35	9.779	74	2.28	113	0.697
-3	57.18	36	9.382	75	2.206	114	0.678
-2	54.31	37	9.003	76	2.133	115	0.66
-1	51.59	38	8.642	77	2.064	116	0.642
0	49.02	39	8.297	78	1.997	117	0.625
1	46.6	40	7.967	79	1.933	118	0.608
2	44.31	41	7.653	80	1.871	119	0.592
3	42.14	42	7.352	81	1.811	120	0.577
4	40.09	43	7.065	82	1.754	121	0.561
5	38.15	44	6.791	83	1.699	122	0.547
6	36.32	45	6.529	84	1.645	123	0.532
7	34.58	46	6.278	85	1.594	124	0.519
8	32.94	47	6.038	86	1.544	125	0.505
9	31.38	48	5.809	87	1.497	126	0.492
10	29.9	49	5.589	88	1.451	127	0.48
11	28.51	50	5.379	89	1.408	128	0.467
12	27.18	51	5.197	90	1.363	129	0.456
13	25.92	52	4.986	91	1.322	130	0.444
14	24.73	53	4.802	92	1.282	131	0.433
15	23.6	54	4.625	93	1.244	132	0.422
16	22.53	55	4.456	94	1.207	133	0.412
17	21.51	56	4.294	95	1.171	134	0.401
18	20.54	57	4.139	96	1.136	135	0.391
19	19.63	58	3.99	97	1.103	136	0.382

Resistance Table of Tube Temperature Sensors for Indoor and Outdoor (20K)

Temp(°C)	Resistance(kΩ)	Temp(°C)	Resistance(kΩ)	Temp(°C)	Resistance(kΩ)	Temp(°C)	Resistance(kΩ)
-19	181.4	20	25.01	59	5.13	98	1.427
-18	171.4	21	23.9	60	4.948	99	1.386
-17	162.1	22	22.85	61	4.773	100	1.346
-16	153.3	23	21.85	62	4.605	101	1.307
-15	145	24	20.9	63	4.443	102	1.269
-14	137.2	25	20	64	4.289	103	1.233
-13	129.9	26	19.14	65	4.14	104	1.198
-12	123	27	18.13	66	3.998	105	1.164
-11	116.5	28	17.55	67	3.861	106	1.131
-10	110.3	29	16.8	68	3.729	107	1.099
-9	104.6	30	16.1	69	3.603	108	1.069
-8	99.13	31	15.43	70	3.481	109	1.039
-7	94	32	14.79	71	3.364	110	1.01
-6	89.17	33	14.18	72	3.252	111	0.983
-5	84.61	34	13.59	73	3.144	112	0.956
-4	80.31	35	13.04	74	3.04	113	0.93
-3	76.24	36	12.51	75	2.94	114	0.904
-2	72.41	37	12	76	2.844	115	0.88
-1	68.79	38	11.52	77	2.752	116	0.856
0	65.37	39	11.06	78	2.663	117	0.833
1	62.13	40	10.62	79	2.577	118	0.811
2	59.08	41	10.2	80	2.495	119	0.77
3	56.19	42	9.803	81	2.415	120	0.769
4	53.46	43	9.42	82	2.339	121	0.746
5	50.87	44	9.054	83	2.265	122	0.729
6	48.42	45	8.705	84	2.194	123	0.71
7	46.11	46	8.37	85	2.125	124	0.692
8	43.92	47	8.051	86	2.059	125	0.674
9	41.84	48	7.745	87	1.996	126	0.658
10	39.87	49	7.453	88	1.934	127	0.64
11	38.01	50	7.173	89	1.875	128	0.623
12	36.24	51	6.905	90	1.818	129	0.607
13	34.57	52	6.648	91	1.736	130	0.592
14	32.98	53	6.403	92	1.71	131	0.577
15	31.47	54	6.167	93	1.658	132	0.563
16	30.04	55	5.942	94	1.609	133	0.549
17	28.68	56	5.726	95	1.561	134	0.535
18	27.39	57	5.519	96	1.515	135	0.521
19	26.17	58	5.32	97	1.47	136	0.509

Resistance Table of Discharge Temperature Sensor for Outdoor (50K)

Temp(°C)	Resistance(kΩ)	Temp(°C)	Resistance(kΩ)	Temp(°C)	Resistance(kΩ)	Temp(°C)	Resistance(kΩ)
-29	853.5	10	98	49	18.34	88	4.75
-28	799.8	11	93.42	50	17.65	89	4.61
-27	750	12	89.07	51	16.99	90	4.47
-26	703.8	13	84.95	52	16.36	91	4.33
-25	660.8	14	81.05	53	15.75	92	4.20
-24	620.8	15	77.35	54	15.17	93	4.08
-23	580.6	16	73.83	55	14.62	94	3.96
-22	548.9	17	70.5	56	14.09	95	3.84
-21	516.6	18	67.34	57	13.58	96	3.73
-20	486.5	19	64.33	58	13.09	97	3.62
-19	458.3	20	61.48	59	12.62	98	3.51
-18	432	21	58.77	60	12.17	99	3.41
-17	407.4	22	56.19	61	11.74	100	3.32
-16	384.5	23	53.74	62	11.32	101	3.22
-15	362.9	24	51.41	63	10.93	102	3.13
-14	342.8	25	49.19	64	10.54	103	3.04
-13	323.9	26	47.08	65	10.18	104	2.96
-12	306.2	27	45.07	66	9.83	105	2.87
-11	289.6	28	43.16	67	9.49	106	2.79
-10	274	29	41.34	68	9.17	107	2.72
-9	259.3	30	39.61	69	8.85	108	2.64
-8	245.6	31	37.96	70	8.56	109	2.57
-7	232.6	32	36.38	71	8.27	110	2.50
-6	220.5	33	34.88	72	7.99	111	2.43
-5	209	34	33.45	73	7.73	112	2.37
-4	198.3	35	32.09	74	7.47	113	2.30
-3	199.1	36	30.79	75	7.22	114	2.24
-2	178.5	37	29.54	76	7.00	115	2.18
-1	169.5	38	28.36	77	6.76	116	2.12
0	161	39	27.23	78	6.54	117	2.07
1	153	40	26.15	79	6.33	118	2.02
2	145.4	41	25.11	80	6.13	119	1.96
3	138.3	42	24.13	81	5.93	120	1.91
4	131.5	43	23.19	82	5.75	121	1.86
5	125.1	44	22.29	83	5.57	122	1.82
6	119.1	45	21.43	84	5.39	123	1.77
7	113.4	46	20.6	85	5.22	124	1.73
8	108	47	19.81	86	5.06	125	1.68
9	102.8	48	19.06	87	4.90	126	1.64



JF00303091



GREE ELECTRIC APPLIANCES, INC. OF ZHUHAI

Add: West Jinji Rd, Qianshan, Zhuhai,Guangdong, China, 519070
Tel: (+86-756) 8522218
Fax: (+86-756) 8669426
E-mail: gree@gree.com.cn www.gree.com

HONG KONG GREE ELECTRIC APPLIANCES SALES LIMITED

Add: Unit 2612,26/F.,Miramar Tower 132 Nathan Road,TST,Kowloon,HK
Tel: (852) 31658898 Fax: (852) 31651029

For product improvement, specifications and appearance in this manual are subject to change without prior notice.