

Service Manual

Models: GWH15AAD-K6DNA1A
GWH18AAD-K6DNA1A
GWH24AAD-K6DNA1A
GWH24AAD-K6DNA5A
(Refrigerant R32)

Table of Contents

Part I : Technical Information	1
1. Summary	1
2. Specifications	3
2.1 Specification Sheet.....	3
2.2 Operation Characteristic Curve	7
2.2 Capacity Curve in Different Outdoor Temperature	7
2.3 Cooling and Heating Data Sheet in Rated Frequency	7
2.5 Noise Curve.....	8
3. Outline Dimension Diagram	9
3.1 Indoor Unit.....	9
3.2 Outdoor Unit.....	10
4. Refrigerant System Diagram	12
5. Electrical Part	13
5.1 Wiring Diagram.....	13
5.2 PCB Printed Diagram	15
6. Function and Control	18
6.1 Remote Controller Introduction	18
6.2 GREE+ App Operation Manual	22
6.3 Ewpe Smart App Operation Manual	23
6.4 Brief Description of Modes and Functions.....	24
Part II : Installation and Maintenance	33
7. Notes for Installation and Maintenance	33
8. Installation	37
8.1 Installation Dimension Diagram.....	37
8.2 Installation Parts-checking	39
8.3 Selection of Installation Location.....	39
8.4 Electric Connection Requirement.....	39
8.5 Installation of Indoor Unit.....	39
8.6 Installation of Outdoor unit	42
8.7 Vacuum Pumping and Leak Detection	43
8.8 Check after Installation and Test operation	43

GWH24AAD-K6DNA1A/O

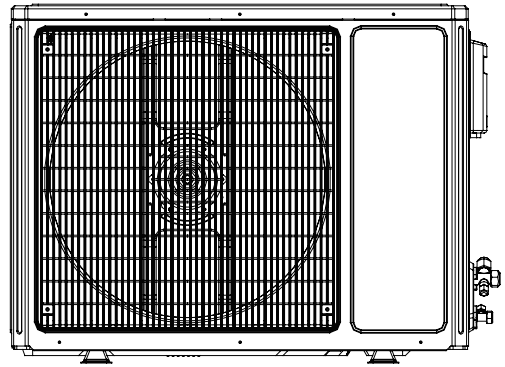

Remote Controller:

YAW1F



2. Specifications

2.1 Specification Sheet

Model			GWH18AAD-K6DNA1A	GWH24AAD-K6DNA1A GWH24AAD-K6DNA5A
Product Code			CB476000200	CB476000100 CB488000500
Power Supply	Rated Voltage	V~	220-240	220-240
	Rated Frequency	Hz	50	50
	Phases		1	1
Power Supply Mode			Outdoor	Outdoor
Cooling Capacity		W	5130	6155
Heating Capacity		W	5280	6448
Cooling Power Input		W	1600	1760
Heating Power Input		W	1450	1860
Cooling Power Current		A	7.0	7.7
Heating Power Current		A	6.3	8.1
Rated Input		W	2300	2600
Rated Current		A	10.8	10.9
Rated Heating Current		A	12	11.3
Air Flow Volume(SH/H/M/L/SL)		m ³ /h	850/720/610/520/-	850/720/610/520/-
Dehumidifying Volume		L/h	1.8	1.8
EER		W/W	3.21	3.5
COP		W/W	3.64	3.47
SEER		W/W	6.1	6.1
HSPF		W/W	/	/
Application Area		m ²	23-34	23-24
Indoor Unit	Model of Indoor Unit		GWH18AAD-K6DNA1A/I	GWH24AAD-K6DNA1A/I GWH24AAD-K6DNA5A/I
	Product Code of Indoor Unit		CB476N00200	CB476N00100 CB488N00500
	Fan Type		Cross-flow	Cross-flow
	Diameter Length(DXL)		mm	Φ106X706
	Fan Motor Cooling Speed(SH/H/M/L/SL)		r/min	1230/1130/1030/800/-
	Fan Motor Heating Speed(SH/H/M/L/SL)		r/min	1350/1200/1050/900/-
	Output of Fan Motor		W	35
	Fan Motor RLA		A	0.35
	Fan Motor Capacitor		μF	2.5
	Input of Heater		W	/
	Evaporator Form			Aluminum Fin-copper Tube
	Pipe Diameter		mm	Φ7
	Row-fin Gap		mm	2-1.4
	Coil Length (LXDXW)		mm	715X25.4X304.8
	Swing Motor Model			MP35CP
	Output of Swing Motor		W	2.5
	Fuse		A	3.15
	Sound Pressure Level (SH/H/M/L/SL)		dB (A)	48/44/39/34/-
	Sound Power Level (SH/H/M/L/SL)		dB (A)	58/54/49/44/-
	Dimension (WXHXD)		mm	970X300X225
	Dimension of Carton Box (LXWXH)		mm	1017X366X285
Dimension of Package (LXWXH)		mm	1020X369X295	
Net Weight		kg	13.5	
Gross Weight		kg	16.5	

Outdoor Unit	Model of Outdoor Unit		GWH18AAD-K6DNA1A/O	GWH24AAD-K6DNA1A/O
	Product Code of Outdoor Unit		CB476W00200	CB476W00100
	Compressor Manufacturer/Trademark		ZHUHAI LANDA COMPRESSOR CO.,LTD	ZHUHAI LANDA COMPRESSOR CO.,LTD
	Compressor Model		QXF-B141ZF030A	QXF-B141ZF030A
	Compressor Oil		68DA	68DA
	Compressor Type		Rotary	Rotary
	L.R.A.	A	25	25
	Compressor RLA	A	6.5	6.5
	Compressor Power Input	W	1410	1410
	Overload Protector		1NT11L-6233/KSD115°C/HPC 115/95	1NT11L-6233/KSD115°C/HPC 115/95
	Throttling Method		Electron expansion valve	Electron expansion valve
	Operation Temp	°C	16~30	16~30
	Ambient Temp (Cooling)	°C	-15~43	-15~43
	Ambient Temp (Heating)	°C	-15~24	-15~24
	Condenser Form		Aluminum Fin-copper Tube	Aluminum Fin-copper Tube
	Pipe Diameter	mm	Φ7.94	Φ7
	Rows-fin Gap	mm	2-1.4	2-1.4
	Coil Length (LXDXW)	mm	742X38.1X550	935X38.1X660
	Fan Motor Speed	rpm	780	780
	Output of Fan Motor	W	40	60
	Fan Motor RLA	A	0.62	0.49
	Fan Motor Capacitor	μF	/	/
	Air Flow Volume of Outdoor Unit	m ³ /h	2400	3200
	Fan Type		Axial-flow	Axial-flow
	Fan Diameter	mm	Φ445	Φ520
	Defrosting Method		/	/
	Climate Type		T1	T1
	Isolation		I	I
	Moisture Protection		IPX4	IPX4
	Permissible Excessive Operating Pressure for the Discharge Side	MPa	4.3	4.3
	Permissible Excessive Operating Pressure for the Suction Side	MPa	2.5	2.5
	Sound Pressure Level (H/M/L)	dB (A)	56/-/-	57/-/-
Sound Power Level (H/M/L)	dB (A)	66/-/-	67/-/-	
Dimension (WXHXD)	mm	899X596X378	955X700X396	
Dimension of Carton Box (LXWXH)	mm	945X417X630	1026X455X735	
Dimension of Package (LXWXH)	mm	948X420X645	1029X458X750	
Net Weight	kg	39	49	
Gross Weight	kg	42	50.5	
Refrigerant		R32	R32	
Refrigerant Charge	kg	0.9	1.3	
Connection Pipe	Length	m	5	5
	Gas Additional Charge	g/m	16	40
	Outer Diameter Liquid Pipe	mm	Φ6	Φ6
	Outer Diameter Gas Pipe	mm	Φ12	Φ16
	Max Distance Height	m	10	10
	Max Distance Length	m	25	25
Note: The connection pipe applies metric diameter.				

The above data is subject to change without notice; please refer to the nameplate of the unit.

Model			GWH15AAD-K6DNA1A	
Product Code			CB476000600	
Power Supply	Rated Voltage	V~	220-240	
	Rated Frequency	Hz	50	
	Phases		1	
Power Supply Mode			Outdoor	
Cooling Capacity		W	4600	
Heating Capacity		W	5200	
Cooling Power Input		W	1430	
Heating Power Input		W	1400	
Cooling Power Current		A	6.3	
Heating Power Current		A	6.2	
Rated Input		W	1700	
Rated Current		A	8	
Rated Heating Current		A	7.5	
Air Flow Volume(SH/H/M/L/SL)		m ³ /h	850/720/610/520/-	
Dehumidifying Volume		L/h	1.8	
EER		W/W	3.22	
COP		W/W	3.71	
SEER		W/W	6.1	
HSPF		W/W	/	
Application Area		m ²	21-31	
Indoor Unit	Model of Indoor Unit		GWH15AAD-K6DNA1A/I	
	Product Code of Indoor Unit		CB476N00600	
	Fan Type		Cross-flow	
	Diameter Length(DXL)		mm	Φ106X706
	Fan Motor Cooling Speed(SH/H/M/L/SL)		r/min	1230/1130/1030/800/-
	Fan Motor Heating Speed(SH/H/M/L/SL)		r/min	1350/1200/1050/900/-
	Output of Fan Motor		W	/
	Fan Motor RLA		A	0.35
	Fan Motor Capacitor		μF	2.5
	Input of Heater		W	/
	Evaporator Form			Aluminum Fin-copper Tube
	Pipe Diameter		mm	Φ7
	Row-fin Gap		mm	2-1.4
	Coil Length (LXDXW)		mm	715X25.4X304.8
	Swing Motor Model			MP35CP
	Output of Swing Motor		W	2.5
	Fuse		A	3.15
	Sound Pressure Level (SH/H/M/L/SL)		dB (A)	49/45/41/36/-
	Sound Power Level (SH/H/M/L/SL)		dB (A)	58/55/51/46/-
	Dimension (WXHDX)		mm	970X300X225
	Dimension of Carton Box (LXWXH)		mm	1017X366X285
Dimension of Package (LXWXH)		mm	1020X369X295	
Net Weight		kg	13.5	
Gross Weight		kg	16.5	

Outdoor Unit	Model of Outdoor Unit		GWH15AAD-K6DNA1A/O
	Product Code of Outdoor Unit		CB476W00600
	Compressor Manufacturer/Trademark		ZHUHAI LANDA COMPRESSOR CO., LTD
	Compressor Model		QXF-B096zE190A
	Compressor Oil		FW68DA
	Compressor Type		Rotary
	L.R.A.	A	20
	Compressor RLA	A	4.21
	Compressor Power Input	W	943
	Overload Protector		/
	Throttling Method		Capillary
	Operation Temp	°C	16~30
	Ambient Temp (Cooling)	°C	-15~43
	Ambient Temp (Heating)	°C	-15~24
	Condenser Form		Aluminum Fin-copper Tube
	Pipe Diameter	mm	Φ7
	Rows-fin Gap	mm	2-1.4
	Coil Length (LXD _{XW})	mm	742X38.1X550
	Fan Motor Speed	rpm	900
	Output of Fan Motor	W	30
	Fan Motor RLA	A	0.4
	Fan Motor Capacitor	μF	/
	Air Flow Volume of Outdoor Unit	m ³ /h	2200
	Fan Type		Axial-flow
	Fan Diameter	mm	Φ438
	Defrosting Method		Automatic Defrosting
	Climate Type		T1
	Isolation		I
	Moisture Protection		IPX4
	Permissible Excessive Operating Pressure for the Discharge Side	MPa	4.3
Permissible Excessive Operating Pressure for the Suction Side	MPa	2.5	
Sound Pressure Level (H/M/L)	dB (A)	54/-/-	
Sound Power Level (H/M/L)	dB (A)	64/-/-	
Dimension (WXH _{XD})	mm	848X596X320	
Dimension of Carton Box (LXWXH)	mm	878X360X630	
Dimension of Package (LXWXH)	mm	881X363X645	
Net Weight	kg	34	
Gross Weight	kg	37	
Refrigerant		R32	
Refrigerant Charge	kg	0.77	
Connection Pipe	Length	m	5
	Gas Additional Charge	g/m	16
	Outer Diameter Liquid Pipe	mm	Φ6
	Outer Diameter Gas Pipe	mm	Φ9.52
	Max Distance Height	m	10
	Max Distance Length	m	20
Note: The connection pipe applies metric diameter.			

The above data is subject to change without notice; please refer to the nameplate of the unit.

2.2 Operation Characteristic Curve

Cooling

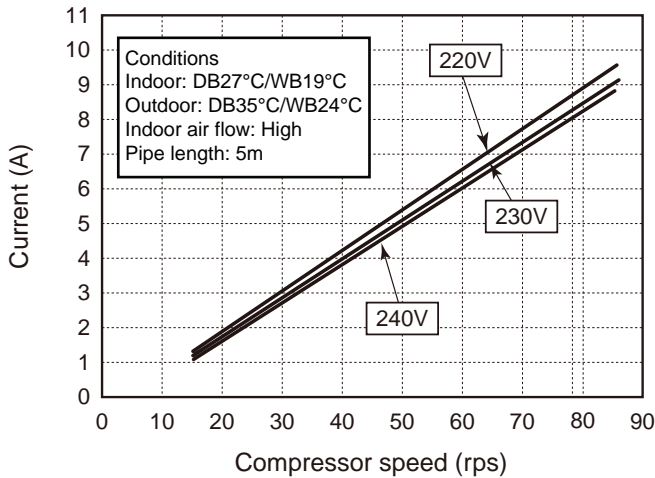

Heating

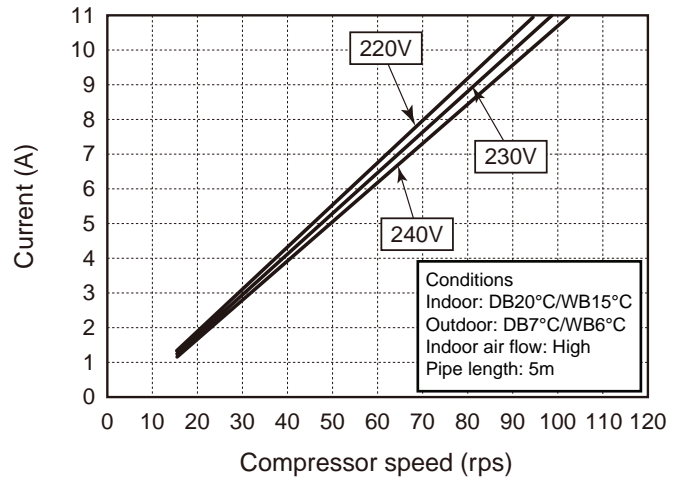

2.2 Capacity Curve in Different Outdoor Temperature

Cooling

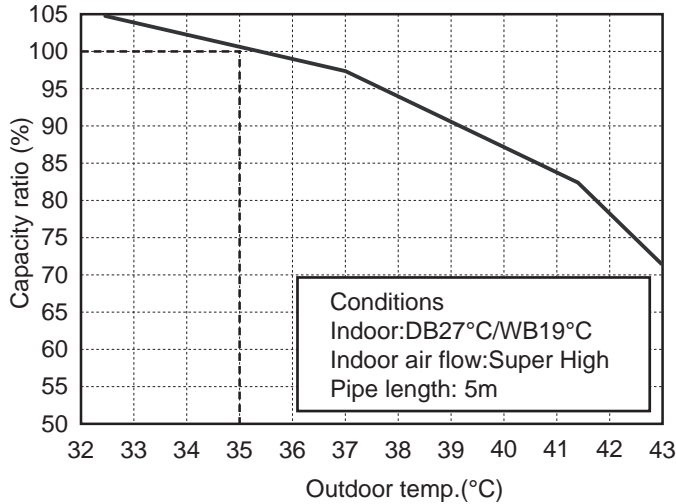

Heating

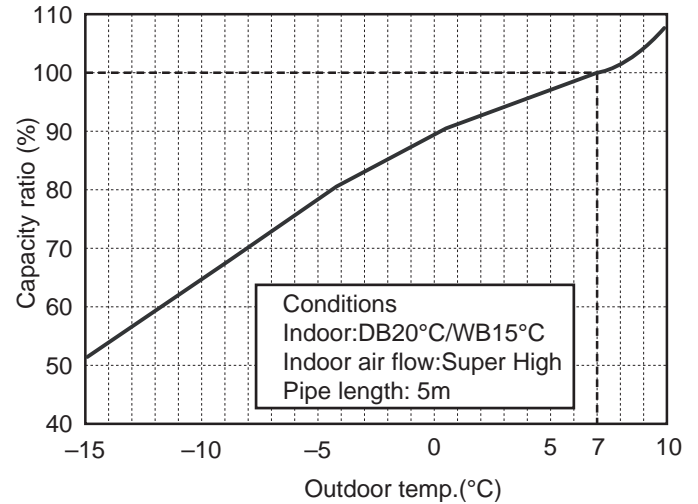

2.3 Cooling and Heating Data Sheet in Rated Frequency

Cooling

Rated cooling condition(°C) (DB/WB)		Model	Pressure of gas pipe connecting indoor and outdoor unit P (MPa)	Inlet and outlet pipe temperature of heat exchanger		Fan speed of indoor unit	Fan speed of outdoor unit
Indoor	Outdoor			T1 (°C)	T2 (°C)		
27/19	35/24	15/18/24K	0.8~1.0	in:8~11 out:11~14	in:75~85 out:37~43	Super High	High

Heating

Rated heating condition(°C) (DB/WB)		Model	Pressure of gas pipe connecting indoor and outdoor unit P (MPa)	Inlet and outlet pipe temperature of heat exchanger		Fan speed of indoor unit	Fan speed of outdoor unit
Indoor	Outdoor			T1 (°C)	T2 (°C)		
20/-	7/6	15/18/24K	3.5~3.8	in:75~85 out:37~43	in:1~3 out:2~5	Super High	High

Instruction:

T1: Inlet and outlet pipe temperature of evaporator

T2: Inlet and outlet pipe temperature of condenser

P: Pressure at the side of big valve

Connection pipe length: 5m.

2.5 Noise Curve

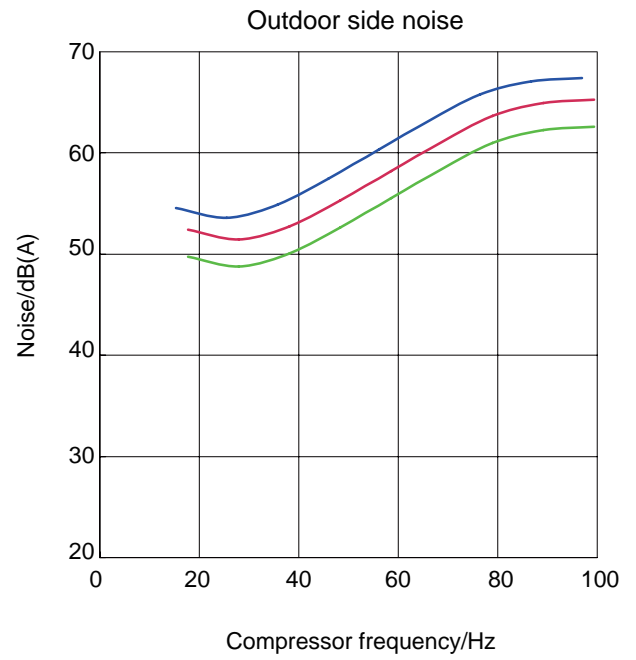
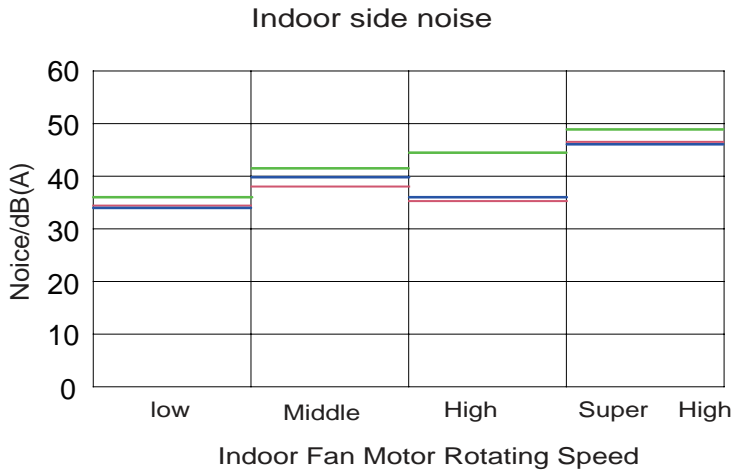

— 15K — 24K — 18K

3. Outline Dimension Diagram

3.1 Indoor Unit

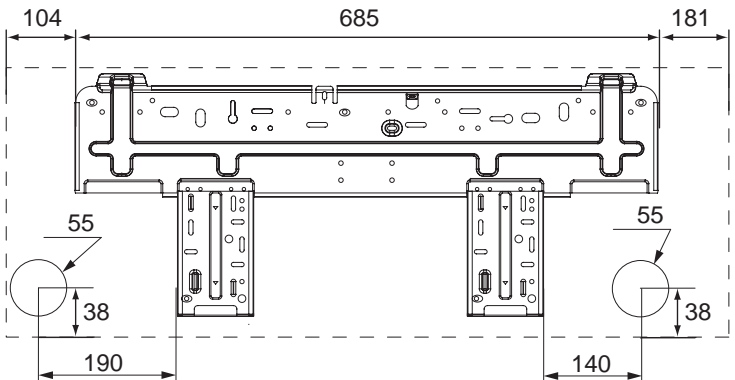
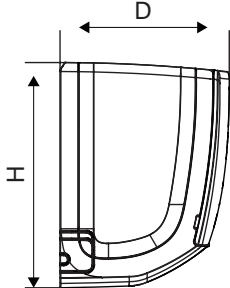
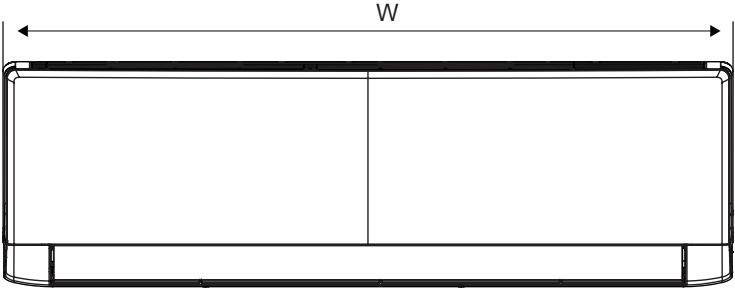

Unit:mm

Model	W	H	D
15/18/24K	970	300	225

3.2 Outdoor Unit

18K

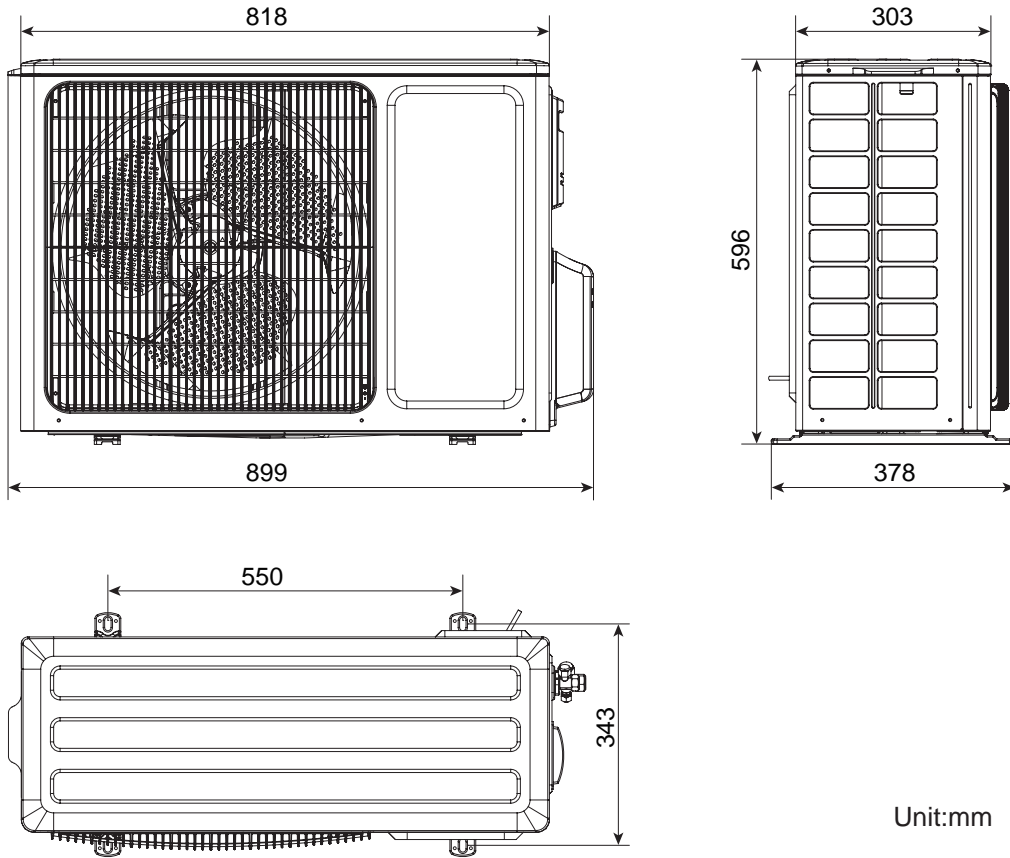

24K

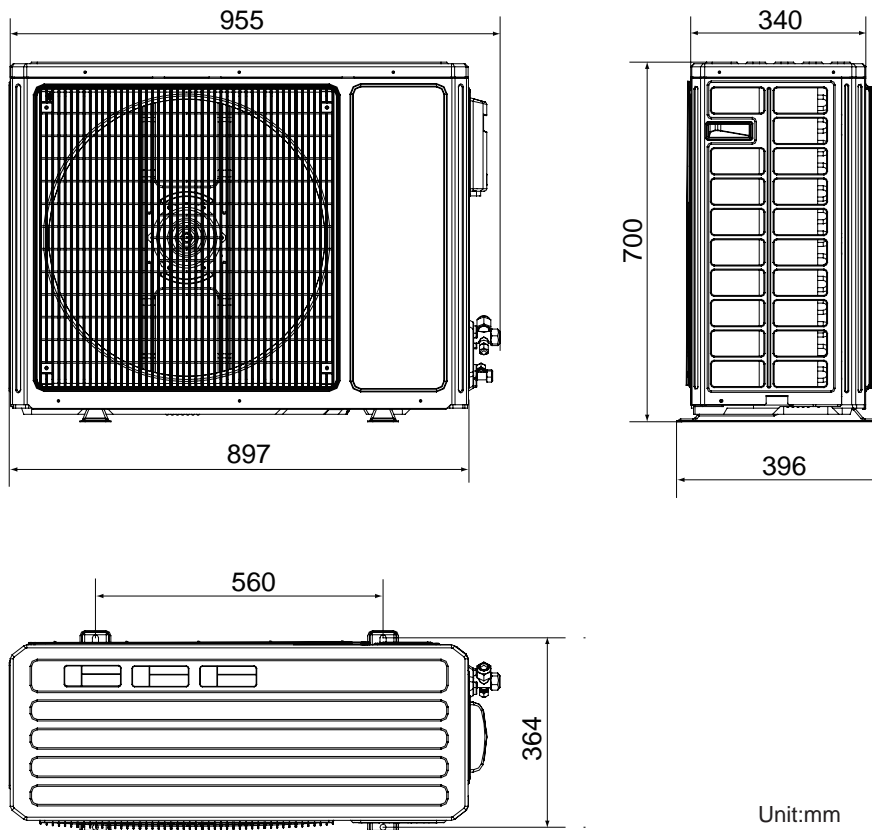

4. Refrigerant System Diagram

18/24K

Cooling and heating model
Indoor unit

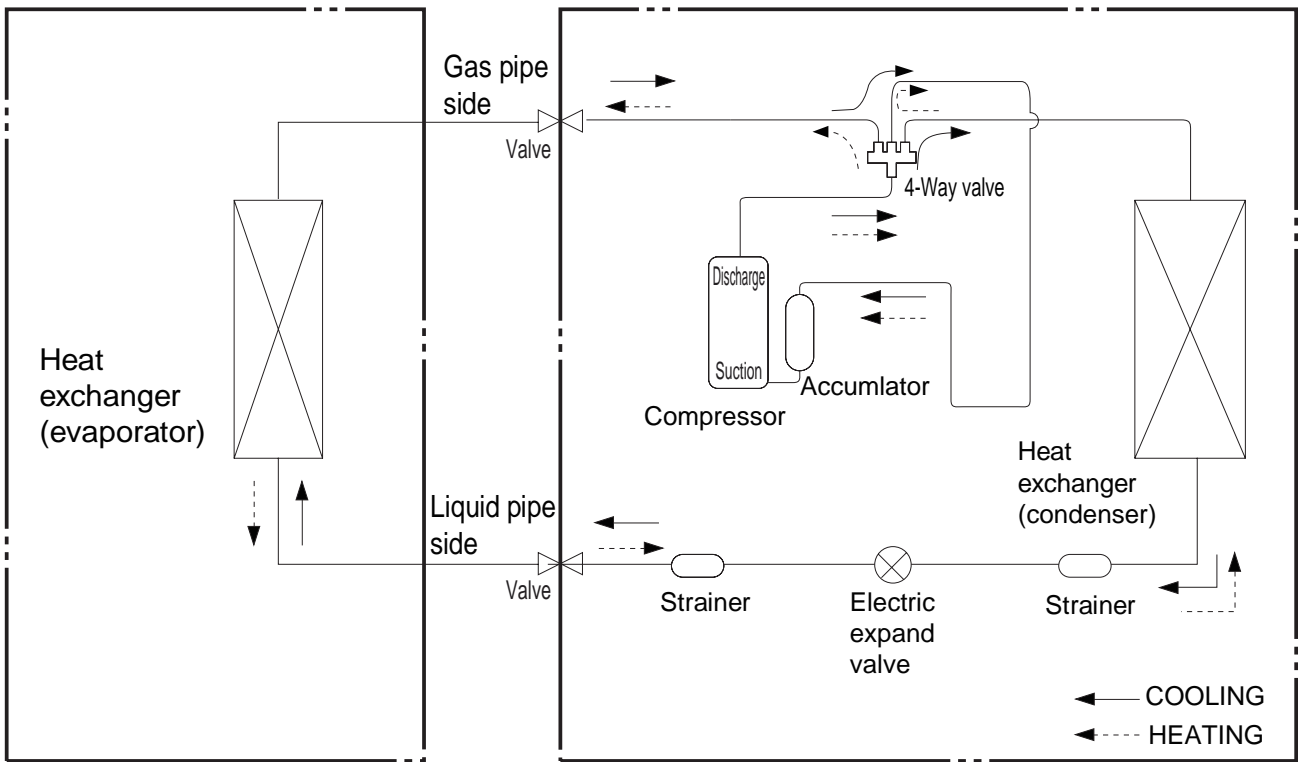

15K

Cooling and heating model
Indoor unit

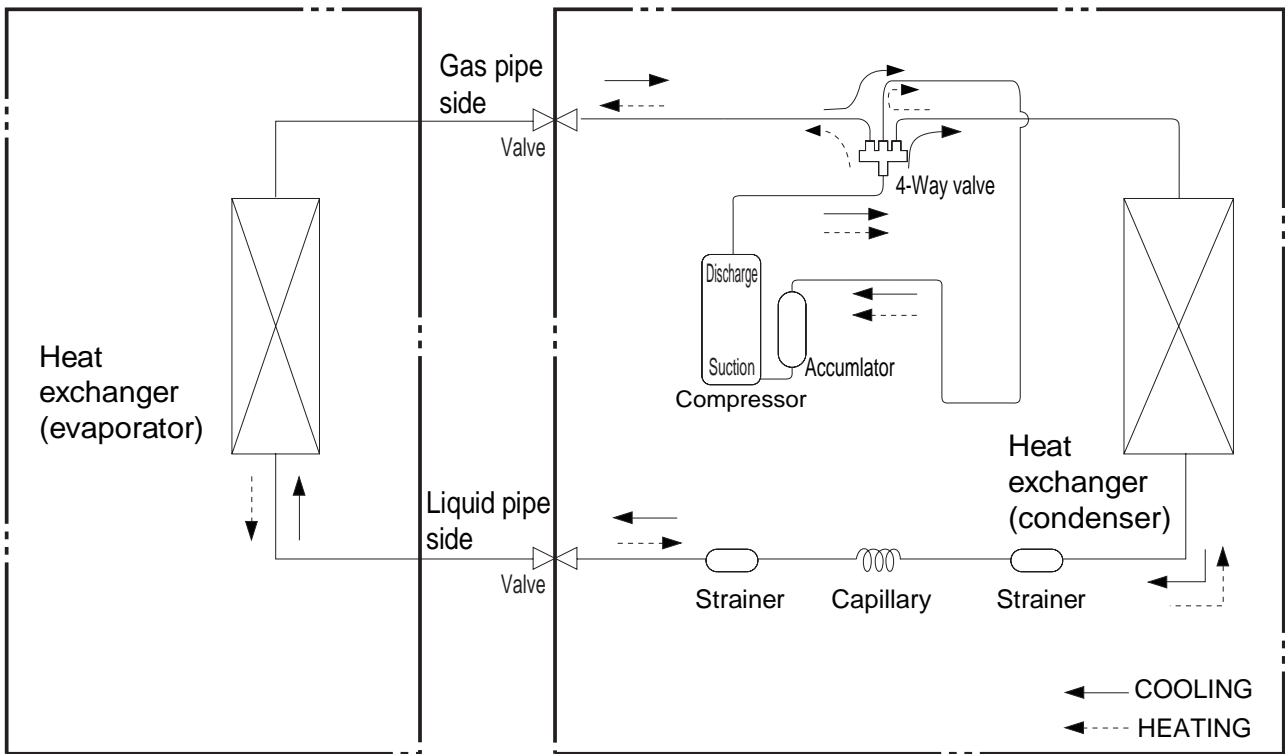

Connection pipe specification:

Liquid pipe: 1/4" (6mm)

Gas pipe: 3/8" (9.52mm) 15K

Gas pipe: 1/2" (12mm) 18K Gas pipe: 5/8" (16mm) 24K

5. Electrical Part

5.1 Wiring Diagram

● Instruction

Symbol	Symbol Color	Symbol	Symbol Color	Symbol	Name
WH	White	GN	Green	CAP	Jumper cap
YE	Yellow	BN	Brown	COMP	Compressor
RD	Red	BU	Blue	⊕	Grounding wire
YEGN	Yellow/Green	BK	Black	/	/
VT	Violet	OG	Orange	/	/

Note: Jumper cap is used to determine fan speed and the swing angle of horizontal lover for this model.

● Indoor Unit

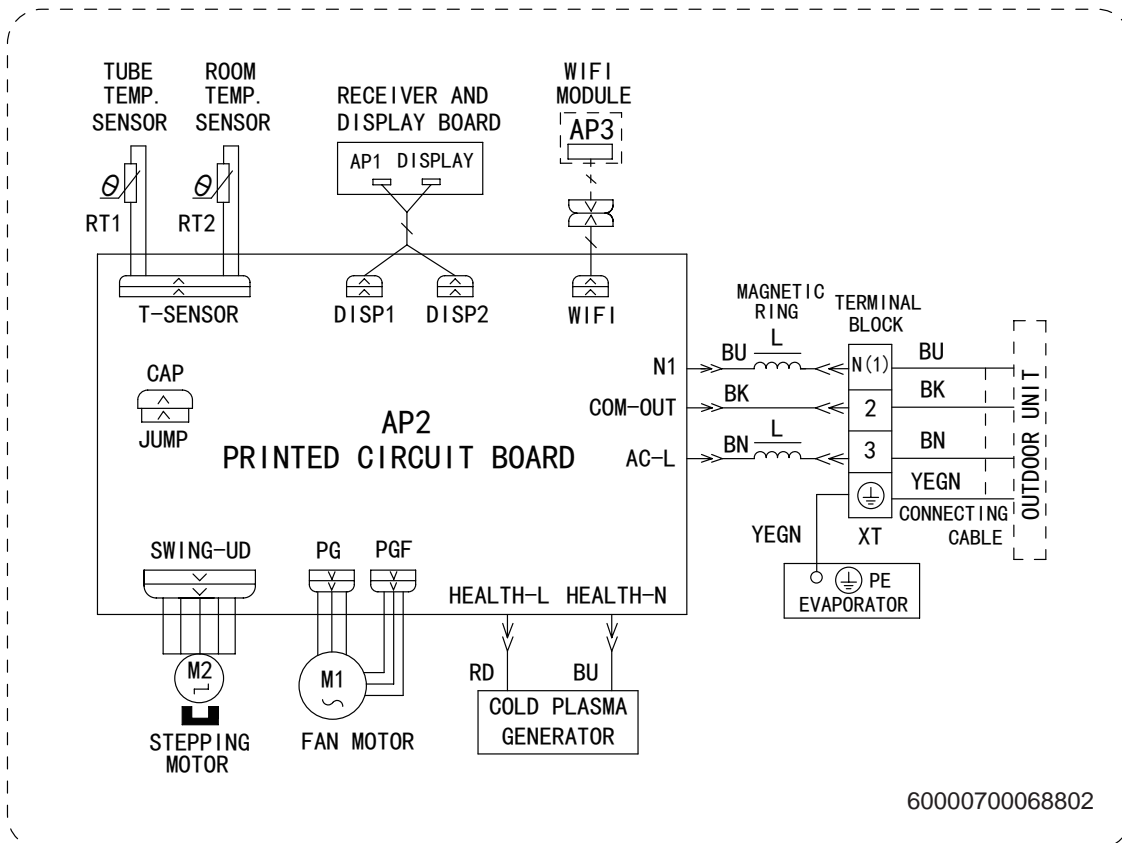

• Outdoor Unit

GWH18AAD-K6DNA1A/O GWH24AAD-K6DNA1A/O

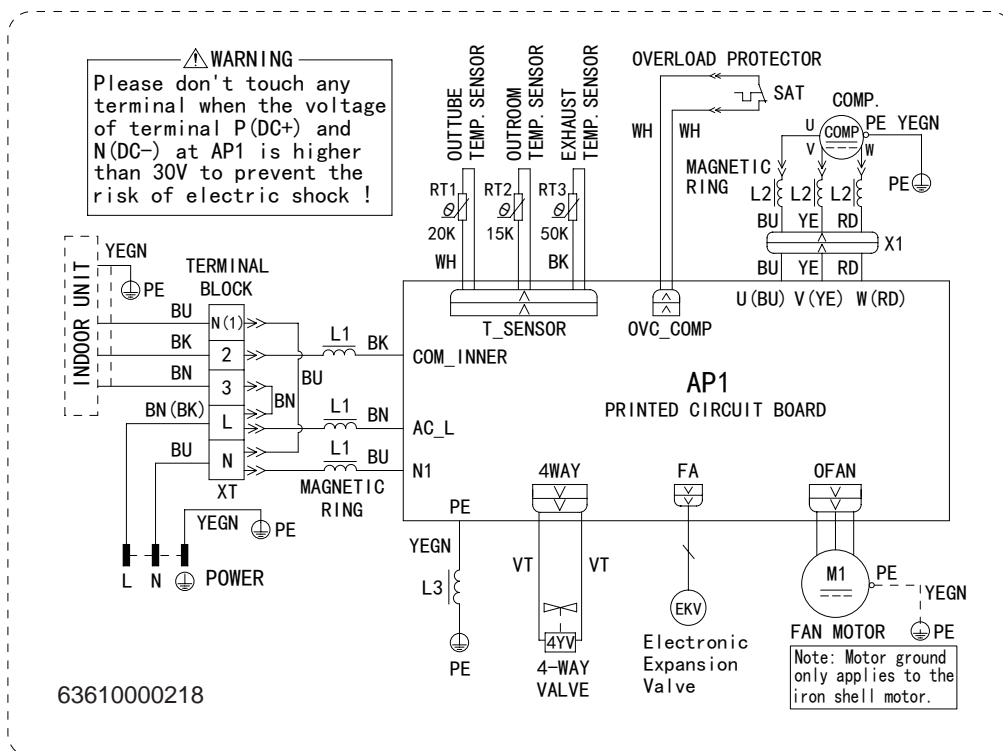

GWH15AAD-K6DNA1A/O

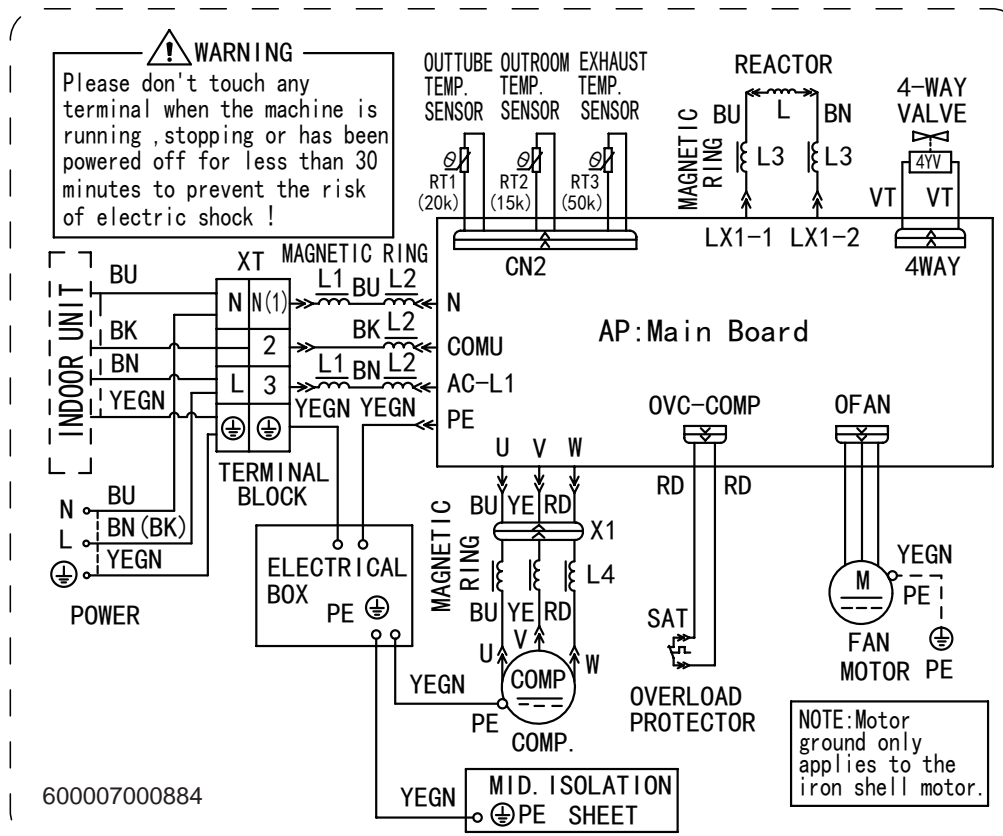

These wiring diagrams are subject to change without notice; please refer to the one supplied with the unit.

5.2 PCB Printed Diagram

Indoor Unit

• Top view

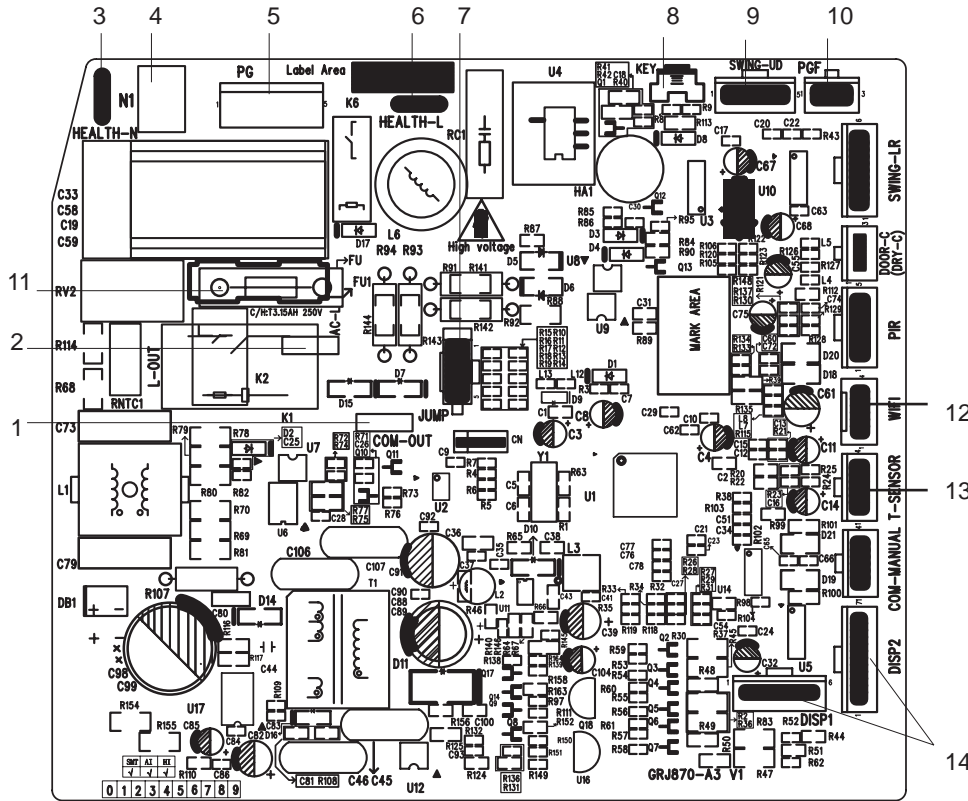

No	Name
1	Interface of communication wire for indoor unit and outdoor unit
2	Interface of live wire
3	Interface of health function neutral wire
4	Interface of neutral wire
5	Interface of fan
6	Interface of health function live wire
7	Jumper cap
8	Auto button
9	Up&down swing interface
10	Feedback interface of indoor unit
11	Fuse
12	Interface of wifi
13	Needle stand for tube temperature sensor
14	Display interface

• Bottom view

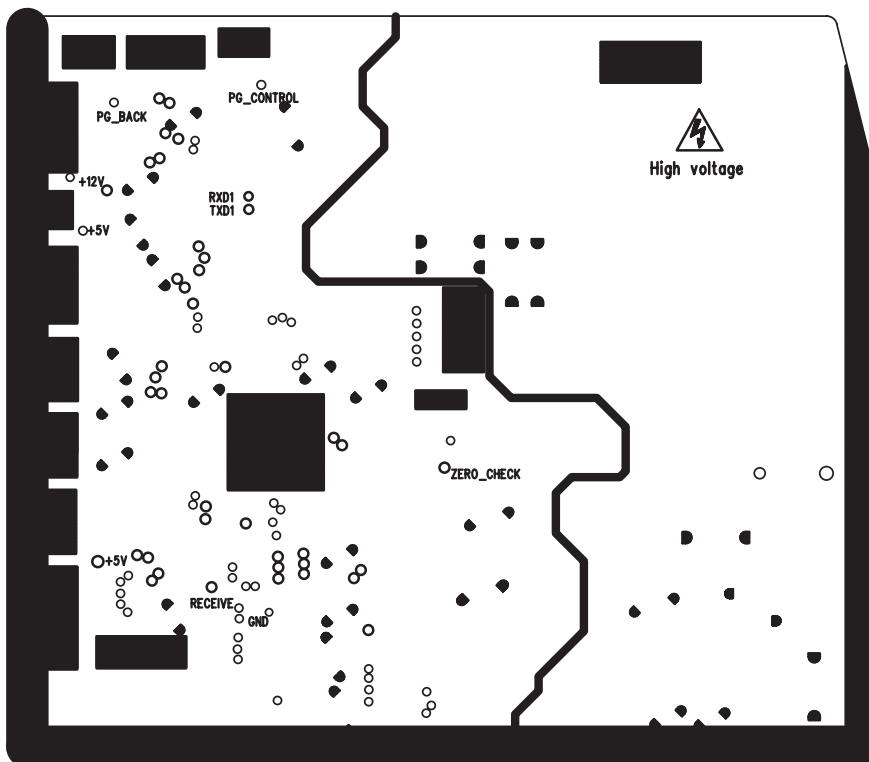

Outdoor Unit

18/24K

• Top view

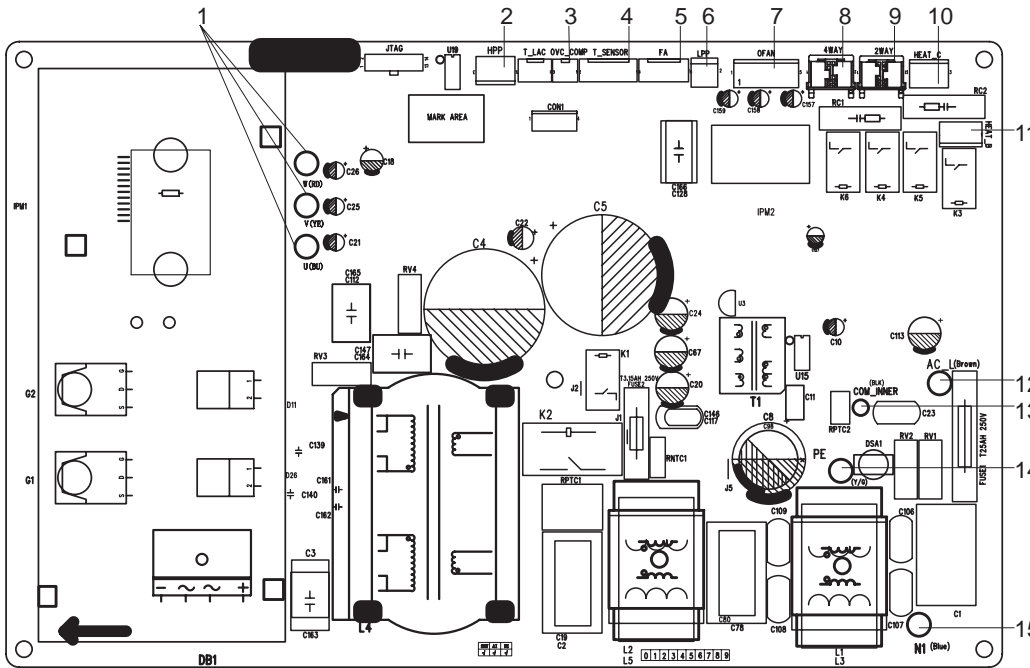

No.	Name
1	Compressor three phase input interface
2	Terminal of system high pressure protection
3	Compressor overload protection terminal
4	Interface of temperature sensor
5	Terminal of electronic expansion valve
6	Terminal for low pressure protection
7	Interface of fan
8	4-way valve terminal
9	2-way valve terminal
10	Terminal of compressor electric heater
11	Terminal of chassis electric heater
12	Live wire
13	Communication wire
14	Grounding wire
15	Neutral wire

• Bottom view

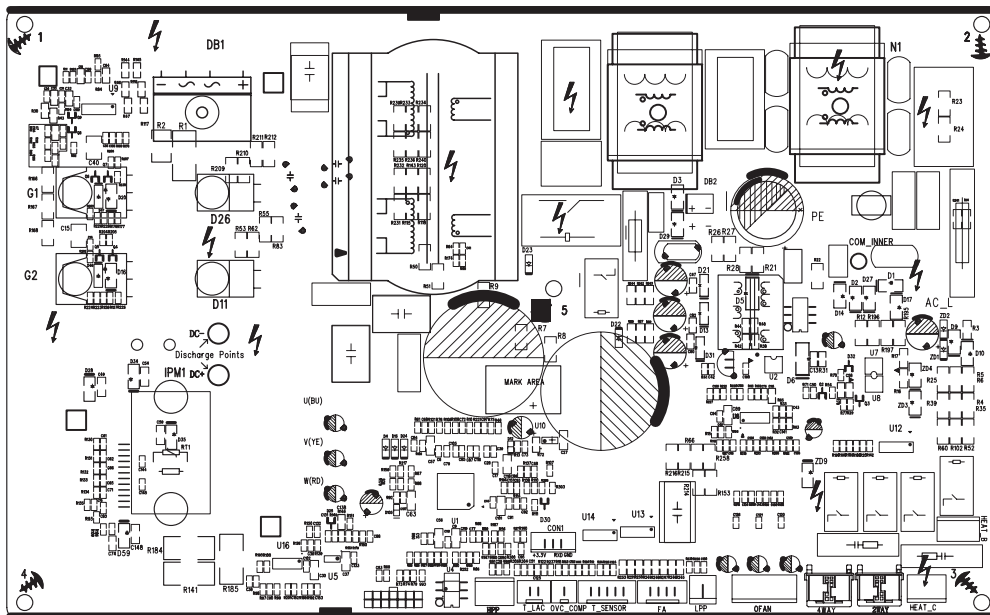

6. Function and Control

6.1 Remote Controller Introduction

Buttons on Remote Controller

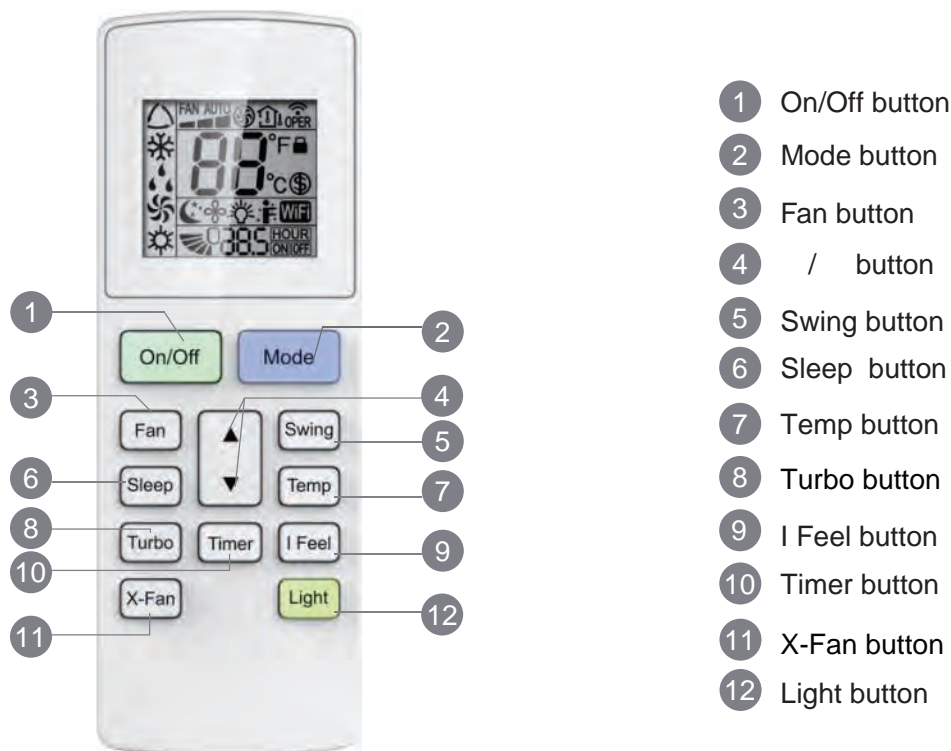

- 1 On/Off button
- 2 Mode button
- 3 Fan button
- 4 / button
- 5 Swing button
- 6 Sleep button
- 7 Temp button
- 8 Turbo button
- 9 I Feel button
- 10 Timer button
- 11 X-Fan button
- 12 Light button

Icon Display on Remote Controller

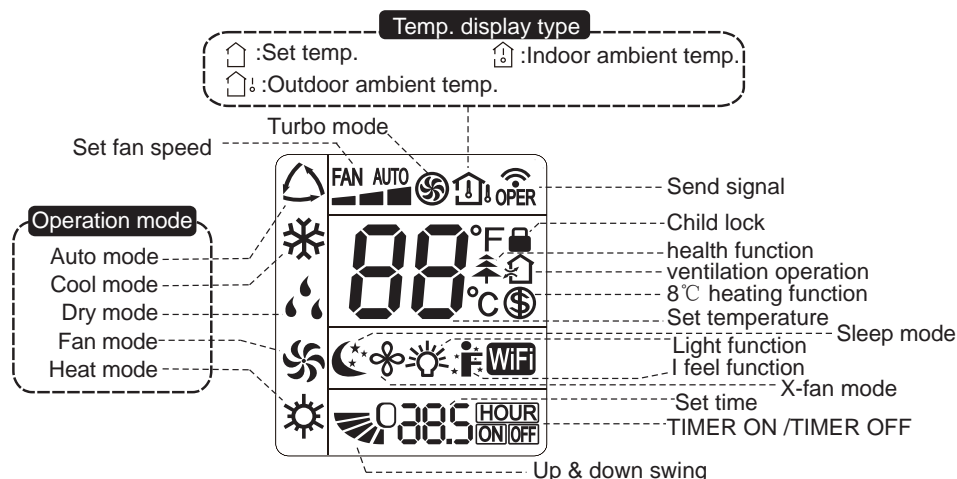

NOTICE: "WIFI" This is a general remote controller. Some models have this function while some do not. Please refer to the actual models.

Operation introduction of remote controller

This is a general use remote controller, it could be used for the air conditioners with multifunction; For some function, which the model doesn't have, if press the corresponding button on the remote controller that the unit will keep the original running status. After putting through the power, the air conditioner will give out a sound. Operation indicator "U" is ON (red indicator). After that, you can operate the air conditioner by using remote controller.

Under on status, pressing the button on the remote controller, the signal icon "W" on the display of remote controller will blink once and the air conditioner will give out a "de" sound, which means the signal has been sent to the air conditioner.

Under off status, set temperature and clock icon will be displayed on the display of remote controller (If timer on, timer off and light functions are set, the corresponding icons will be displayed on the display of remote controller at the same time); Under on status, the display will show the corresponding set function icons.

1. ON/OFF button

Press this button to turn on the unit. Press this button again to turn off the unit.

2. MODE button

Each time you press this button, a mode is selected in a sequence that goes from AUTO, COOL, DRY, FAN, and HEAT *, as the following:

* Note: Only for models with heating function.



- When selecting auto mode, air conditioner will operate automatically according to exfactory setting. Set temperature can't be adjusted and will not be displayed as well. Press "Fan" button can adjust fan speed. Press "Swing" button can adjust fan blowing angle.
- When selecting cool mode, air conditioner will operate under cool mode. Cool indicator "❄" on indoor unit is ON. Press " " or " " button to adjust set temperature. Press "Fan" button to adjust fan speed. Press "Swing" button to adjust fan blowing angle.
- When selecting dry mode, the air conditioner operates at low speed under dry mode. Dry indicator "☀" on indoor unit is ON. Under dry mode, fan speed can't be adjusted. Press "Swing" button to adjust fan blowing angle.
- When selecting fan mode, the air conditioner will only blow fan, no cooling and no heating. All mode indicators on indoor display are off. Press "Fan" button to adjust fan speed. Press "Swing" button to adjust fan blowing angle.
- When selecting heating mode, the air conditioner operates under heat mode. Heat indicator "🔥" on indoor unit is ON. Press " " or " " button to adjust set temperature. Press "Fan" button to adjust fan speed. Press "Swing" button to adjust fan blowing angle. (Cooling only unit won't receive heating mode signal. If setting heat mode with remote controller, press ON/OFF button can't start up the unit).

Note:

- For preventing cold air, after starting up heating mode, indoor unit will delay 1~5 minutes to blow air (actual delay time is depend on indoor ambient temperature).
- Set temperature range from remote controller: 16~30°C ; Fan speed: auto, low speed, medium speed, high speed.

3. FAN button

This button is used for setting Fan Speed in the sequence that goes from AUTO, , to , then back to Auto.

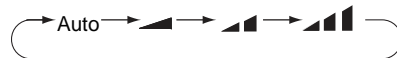

Note:

- Under AUTO speed, air conditioner will select proper fan speed automatically according to ex-factory setting.
- Fan speed under dry mode is low speed.

4. / button

Press / button to increase/decrease set temperature. In AUTO mode, set temperature is not adjustable.

- Press "+" or "-" button once increase or decrease set temperature 1°C. Holding " " or " " button, 2s later, set temperature on remote controller will change quickly. On releasing button after setting is finished, temperature indicator on indoor unit will change accordingly. (Temperature can't be adjusted under auto mode)
- When setting Timer On or Timer Off, press or button to adjust the time. (See TIMER Button for setting details)

5. SWING button

Press this button to set up & down swing angle.

Press this button can select up&down swing angle. Fan blow angle can be selected circularly as below:

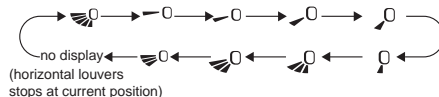

- When selecting "🌀", air conditioner is blowing fan automatically. Horizontal louver will automatically swing up & down at maximum angle.
- When selecting "◀", "↙", "↘", "▶", "↗", "↖", "↕", air conditioner is blowing fan at fixed position. Horizontal louver will stop at the fixed position.
- When selecting "◀", "↙", "↘", "▶", air conditioner is blowing fan at fixed angle. Horizontal louver will send air at the fixed angle.
- Hold "🌀" button above 2s to set your required swing angle. When reaching your required angle, release the button.

Note:

"◀", "↙", "↘", "▶" may not be available. When air conditioner receives this signal, the air conditioner will blow fan automatically.

6. SLEEP button

Under COOL, HEAT or DRY mode, press this button to start up sleep function. "🌙" icon is displayed on remote controller. Press this button again to cancel sleep function and "🌙" icon will disappear.

7. TEMP button

Press this button, you can see indoor set temperature, indoor ambient temperature on indoor unit's display. The setting on remote controller is selected circularly as below:

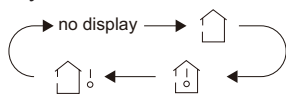

When selecting "🏠" or no display with remote controller, temperature indicator on indoor unit displays set temperature;

When selecting "🏠" with remote controller, temperature indicator on indoor unit displays indoor ambient temperature;

When selecting "🏠" with remote controller, temperature indicator on indoor unit displays outdoor ambient temperature.

Note:

- Outdoor temperature display is not available for some models. At that time, indoor unit receives "🏠" signal, while it displays indoor set temperature.
- It's defaulted to display set temperature when turning on the unit. There is no display in the remote controller.
- Only for the models whose indoor unit has dual-8 display

8. TURBO button

Press this button to activate / deactivate the Turbo function.

Under COOL or HEAT mode, press this button to turn to quick COOL or quick HEAT mode. "⚡" icon is displayed on remote controller. Press this button again to exit turbo function and "⚡" icon will disappear.

9. I FEEL button

Press this button to start I FEEL function and "🌡️" will be displayed on the remote controller. After this function is set, the remote controller will send the detected ambient temperature to the controller and the unit will automatically adjust the indoor temperature according to the detected temperature. Press this button again to close I FEEL function and "🌡️" will disappear.

10. Timer button

- When unit is on, press this button to set Timer Off. OFF and HOUR icon will be blinking. Within 5s, press ▲ or ▼ button to adjust the time for Timer Off. Pressing ▲ or ▼ button once will increase or decrease the time by 0.5h. Hold ▲ or ▼ button for 2s, time will change quickly. Release the button after your required set time is reached. Then press TIMER button to confirm it. OFF and HOUR icon will stop blinking.
- When unit is off, press this button to set Timer On. ON and HOUR icon will be blinking. Within 5s, press ▲ or ▼ button to adjust the time for Timer On. Pressing ▲ or ▼ button once will increase or decrease the time by 0.5h. Hold ▲ or ▼ button for 2s, time will change quickly. Release the button after your required set time is reached. Then press TIMER button to confirm it. ON and HOUR icon will stop blinking.
- Cancel Timer On/Off: If Timer function is set up, press TIMER button once to cancel this function.

Note:

- Range of time setting is: 0.5~24h
- The interval between two motions can't exceed 5s, otherwise the remote controller will exit setting status.

11. X-FAN button (NOTE:X-FAN is the alternative expression of BLOW for the purpose of understanding.)

Press this button under cool and dry mode to start up x-fan function, and "🌀" icon on remote controller will be displayed. Press this button again to cancel x-fan function, and "🌀" icon will disappear.

Note:

- When x-fan function is started up, if the air conditioner is turned off, indoor fan will still operate at low speed for a while to blow the residual water inside the air duct.
- During x-fan operation, press X-FAN button to turn off x-fan function. Indoor fan will stop operation immediately.

12. LIGHT button

Turn on the display's light and press this button again to turn off the display's light.

Press this button to turn off display light on indoor unit. "🌞" icon on remote controller disappears. Press this button again to turn on display light. "🌞" icon is displayed.

NOTICE:

As for the detailed content of remote controller, please refer to QR code on the cover.

Function introduction for combination buttons

Combination of "▲" and "▼" buttons: About lock

Press "▲" and "▼" buttons simultaneously 3s to lock or unlock the keypad. If the remote controller is locked, 📵 is displayed. In this case, pressing any button, 📵 blinks three times.

Combination of "MODE" and "▼" buttons: About switch between Fahrenheit and centigrade

At unit OFF, press "MODE" and "▼" buttons simultaneously to switch between °C and °F.

Combination of "TEMP" and "TIMER" buttons: About Energy-saving Function

Press "TEMP" and "TIMER" simultaneously in COOL mode to start energy-saving function. Nixie tube on the remote controller displays "SE". Repeat the operation to quit the function.

Combination of "TEMP" and "TIMER" buttons: About 8 °C Heating Function

Press "TEMP" and "TIMER" simultaneously in HEAT mode to start 8 °C Heating Function. Nixie tube on the remote controller displays "Ⓢ" and a selected temperature of "8 °C". (46 °F if Fahrenheit is adopted). Repeat the operation to quit the function.

WiFi Function

Press this button to turn on the unit. Press this button again to turn off the unit. Press "MODE" and "TURBO" button simultaneously to turn on or turn off WiFi function. When WiFi function is turned on, the "WiFi" icon will be displayed on remote controller; Long press "MODE" and "TURBO" buttons simultaneously for 10s, remote controller will send WiFi reset code and then the WiFi function will be turned on. WiFi function is defaulted ON after energization of the remote controller.

This function is only available for some models.

Replacement of batteries in remote controller

1. Press the back side of remote controller marked with "🔋", as shown in the fig, and then push out the cover of battery box along the arrow direction.
2. Replace two 7# (AAA 1.5V) dry batteries, and make sure the position of "+" polar and "-" polar are correct.
3. Reinstall the cover of battery box.

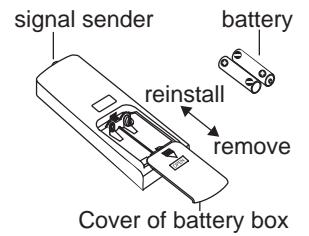

Emergency operation

If remote controller is lost or damaged, please use auxiliary button to turn on or turn off the air conditioner.

The operation in details are as below:

As shown in the fig. Open panel, press aux. button to turn on or turn off the air conditioner.

When the air conditioner is turned on, it will operate under auto mode.

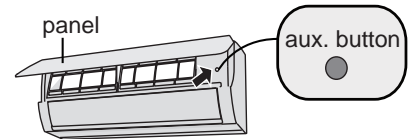

⚠ WARNING:

Use insulated object to press the auto button

6.2 GREE+ App Operation Manual

Control Flow Chart

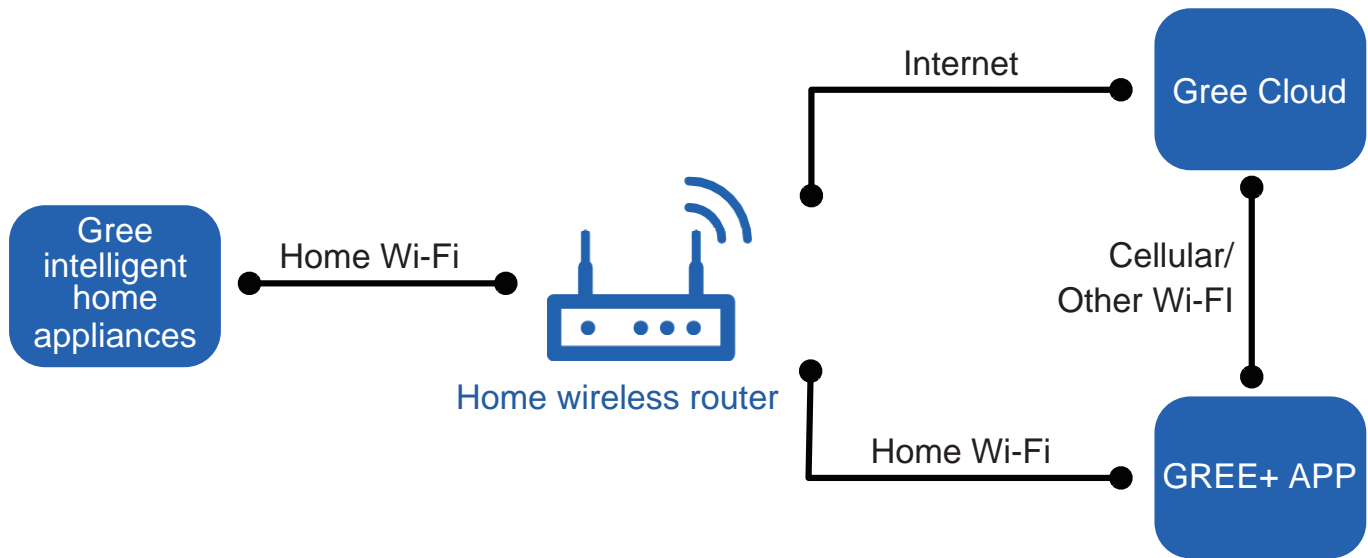

Operating Systems

Requirement for Users smart phone:



iOS system
Support iOS7.0 and
above version



Android system
Support Android 4.0 and
above version

Download and installation



GREE+ App Download Linkage

Scan the QR code or search "GREE+" in the application market to download and install it. When "GREE+" App is installed, register the account and add the device to achieve long-distance control and LAN control of Gree smart home appliances.

For more information, please refer to "Help" in App.

6.3 Ewpe Smart App Operation Manual

Control Flow Chart

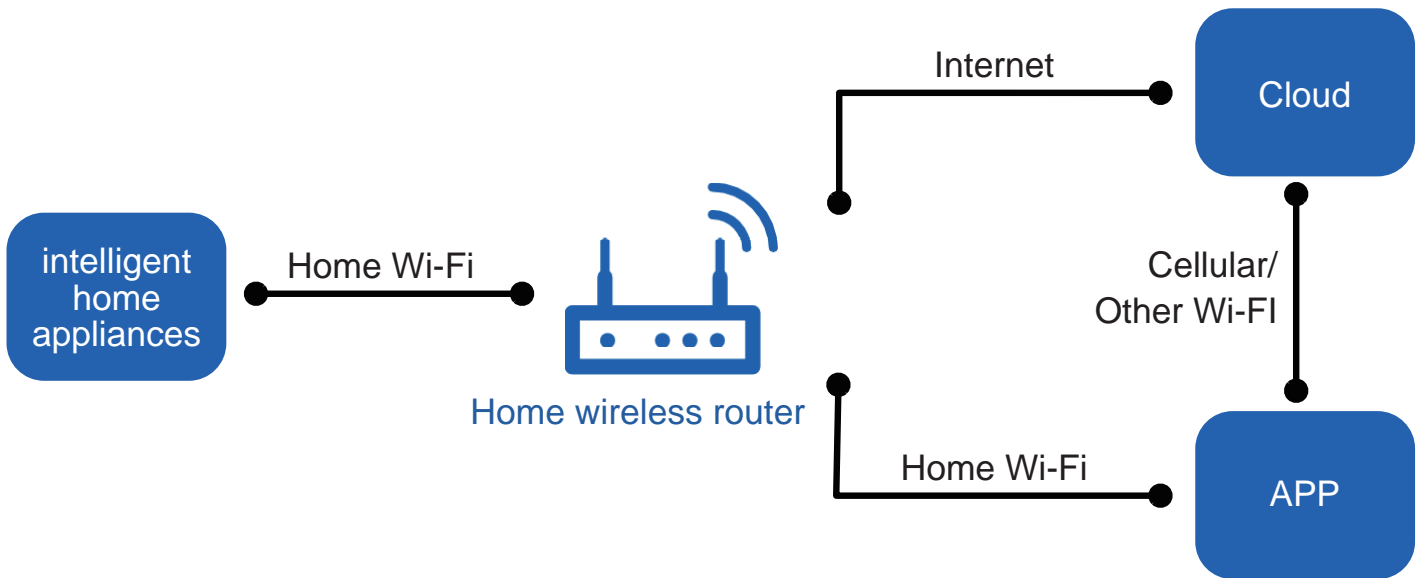

Operating Systems

Requirement for Users smart phone:



iOS system
Support iOS7.0 and
above version



Android system
Support Android 4.0 and
above version

Download and installation



App Download Linkage

Scan the QR code or search "Ewpe Smart" in the application market to download and install it. When "Ewpe Smart" App is installed, register the account and add the device to achieve long-distance control and LAN control of smart home appliances. For more information, please refer to "Help" in App.

6.4 Brief Description of Modes and Functions

1. Basic function of system

(1) Cooling mode

- (1) Under this mode, fan and swing operates at setting status. Temperature setting range is 16~30°C.
- (2) During malfunction of outdoor unit or the unit is stopped because of protection, indoor unit keeps original operation status.

(2) Drying mode

- (1) Under this mode, fan operates at low speed and swing operates at setting status. Temperature setting range is 16~30°C.
- (2) During malfunction of outdoor unit or the unit is stopped because of protection, indoor unit keeps original operation status.
- (3) Protection status is same as that under cooling mode.
- (4) Sleep function is not available for drying mode.

(3) Heating mode

- (1) Under this mode, Temperature setting range is 16~30°C.
- (2) Working condition and process for heating mode:

When turn on the unit under heating mode, indoor unit enters into cold air prevention status. When the unit is stopped or at OFF status, and indoor unit has been started up just now, the unit enters into residual heat-blowing status.

(4) Working method for AUTO mode:

1. Working condition and process for AUTO mode:
 - a. Under AUTO mode, standard heating $T_{\text{preset}}=20^{\circ}\text{C}$ and standard cooling $T_{\text{preset}}=25^{\circ}\text{C}$. The unit will switch mode automatically according to ambient temperature.
2. Protection function
 - a. During cooling operation, protection function is same as that under cooling mode.
 - b. During heating operation, protection function is same as that under heating mode.
3. Display: Set temperature is the set value under each condition. Ambient temperature is ($T_{\text{amb.}}-T_{\text{compensation}}$) for heat pump unit and $T_{\text{amb.}}$ for cooling only unit.
4. If there's I feel function, $T_{\text{compensation}}$ is 0. Others are same as above.

(5) Fan mode

Under this mode, indoor fan operates at set fan speed. Compressor, outdoor fan, 4-way valve and electric heating tube stop operation. Indoor fan can select to operate at high, medium, low or auto fan speed. Temperature setting range is 16~30°C.

2. Other control

(1) Buzzer

Upon energization or availablely operating the unit or remote controller, the buzzer will give out a beep.

(2) Auto button

If press this auto button when turning off the unit, the complete unit will operate at auto mode. Indoor fan operates at auto fan speed and swing function is turned on. Press this auto button at ON status to turn off the unit.

(3) Auto fan

Heating mode: During auto heating mode or normal heating mode, auto fan speed will adjust the fan speed automatically according to ambient temperature and set temperature.

(4) Sleep

After setting sleep function for a period of time, system will adjust set temperature automatically.

(5) Timer function:

General timer and clock timer functions are compatible by equipping remote controller with different functions.

(6) Memory function

memorize compensation temperature, off-peak energization value.

Memory content: mode, up&down swing, light, set temperature, set fan speed, general timer (clock timer can't be memorized).

After power recovery, the unit will be turned on automatically according to memory content.

(7) Health function

During operation of indoor fan, set health function by remote controller. Turn off the unit will also turn off health function.

Turn on the unit by pressing auto button, and the health is defaulted ON.

(8) I feel control mode

After controller received I feel control signal and ambient temperature sent by remote controller, controller will work according to the ambient temperature sent by remote controller.

(9) Compulsory defrosting function

(1) Start up compulsory defrosting function

Under ON status, set heating mode with remote controller and adjust the temperature to 16°C. Press “+, -, +, -, +,-” button successively within 5s and the complete unit will enter into compulsory defrosting status. Meanwhile, heating indicator on indoor unit will ON 10s and OFF 0.5s successively. (Note: If complete unit has malfunction or stops operation due to protection, compulsory defrosting function can be started up after malfunction or protection is resumed.

(2) Exit compulsory defrosting mode

After compulsory defrosting is started up, the complete unit will exit defrosting operation according to the actual defrosting result, and the complete unit will resume normal heating operation.

(10) Refrigerant recovery function:

(1) Enter refrigerant recycling function

Within 5min after energizing (unit ON or OFF status is ok), continuously press LIGHT button for 3 times within 3s to enter refrigerant recycling mode; Fo is displayed and refrigerant recycling function is started. At this moment, the maintenance people closes liquid valve. After 5min, stick the thimble of maintenance valve with a tool. If there is no refrigerant spraying out, close the gas valve immediately and then turn off the unit to remove the connection pipe.

(2) Exit refrigerant recycling function

After entering refrigerant recycling mode, when receive any remote control signal or enter refrigerant recycling mode for 25min, the unit will exit refrigerant recycling mode automatically. If the unit is in standby mode before refrigerant recycling, it will be still in standby mode after finishing refrigerant recycling; if the unit is in ON status before refrigerant recycling, it will still run in original operation mode.

(11) Ambient temperature display control mode

1. When user set the remote controller to display set temperature (corresponding remote control code: 01), current set temperature will be displayed.

2. Only when remote control signal is switched to indoor ambient temperature display status (corresponding remote control code: 10) from other display status (corresponding remote control code: 00, 01,11), controller will display indoor ambient temperature for 3s and then turn back to display set temperature.

Under this mode, indoor fan operates at set fan speed. Compressor, outdoor fan, 4-way valve and electric heating tube stop operation. Indoor fan can select to operate at high, medium, low or auto fan speed. Temperature setting range is 16~30°C.

(12) Off-peak energization function:

Adjust compressors minimum stop time. The original minimum stop time is 180s and then we change to:

The time interval between two start-ups of compressor can't be less than $180+T$ s ($0 \leq T \leq 15$). T is the variable of controller. That's to say the minimum stop time of compressor is 180s~195s. Read-in T into memory chip when refurbish the memory chip each time. After power recovery, compressor can only be started up after $180+T$ s at least.

(13) SE control mode

The unit operates at SE status.

(14) X-fan mode

When X-fan function is turned on, after turn off the unit, indoor fan will still operate at low speed for 2min and then the complete unit will be turned off. When x-fan function is turned off, after turn off the unit, the complete unit will be turned off directly.

(15) 8°C heating function

Under heating mode, you can set 8°C heating function by remote controller. The system will operate at 8°C set temperature.

(16) Turbo fan control function

Set turbo function under cooling or heating mode to enter into turbo fan speed. Press fan speed button to cancel turbo wind.

No turbo function under auto, dry or fan mode.

Outdoor Units

1. Input Parameter Compensation and Calibration

(1) Check the ambient temperature compensation function Indoor ambient temperature compensation function.

a. In cooling mode, the indoor ambient temperature participating in computing control = (T_{indoor ambient temperature} - Δ T_{cooling indoor ambient temperature compensation})

b. In heating mode, the indoor ambient temperature participating in computing control = (T_{indoor ambient temperature} - Δ T_{heating indoor ambient temperature compensation})

(2) Check effective judgment controls of parameters

Effective judgment function of the outdoor exhaust temperature thermo-bulb When conditions a and b are satisfied, the outdoor exhaust temperature thermo-bulb is judged not to be connected into place, the mainboard of outer units will display failure of the outdoor exhaust temperature thermo-bulb (not connected into place), stop the machine for repairing, and resume the machine by remote controls of ON/OFF.

a. Judgment of exhaust detection temperature change:

After the compressor starts up and runs for 10 minutes, if the compressor frequency $f \geq 40\text{Hz}$, and the rising value T_{exhaust} (T_{exhaust} (after start-up for 10 minutes) - T_{exhaust} (before start-up)) $< 2^{\circ}\text{C}$, the outdoor exhaust temperature thermo-bulb can be judged not to be connected into place (judging once when the power is on the first time).

b. Comparative judgment of exhaust detection temperature and condenser detection temperature ($T_{\text{pipe temperature}} = T_{\text{outdoor pipe temperature}}$ in cooling mode, $T_{\text{pipe temperature}} = T_{\text{indoor pipe temperature}}$ in heating mode): After the compressor starts up and runs for 10 minutes, if the compressor frequency $f \geq 40\text{Hz}$, and $T_{\text{pipe temperature}} \geq (T_{\text{exhaust}} + 3)$, the outdoor exhaust temperature thermobulb can be judged not to be connected into place (judging once when power is on the first time).

2. Basic Functions

(1) Cooling Mode

1. Conditions and processes of cooling operation:

(1) If the compressor is shut down, and $[T_{\text{set up}} - (T_{\text{indoor ambient temperature}} - \Delta T_{\text{cooling indoor ambient temperature compensation}})] \leq 0.5^{\circ}\text{C}$, start up the machine for cooling, the cooling operation will start;

(2) During operations of cooling, if $0^{\circ}\text{C} \leq [T_{\text{set up}} - (T_{\text{indoor ambient temperature}} - \Delta T_{\text{cooling indoor ambient temperature compensation}})] < 2^{\circ}\text{C}$, the cooling operation will be still running;

(3) During operations of cooling, if $2^{\circ}\text{C} \leq [T_{\text{set up}} - (T_{\text{indoor ambient temperature}} - \Delta T_{\text{cooling indoor ambient temperature compensation}})]$, the cooling operation will stop after reaching the temperature point.

2. Temperature setting range

(1) If $T_{\text{outdoor ambient temperature}} \geq [T_{\text{low-temperature cooling temperature}}]$, the temperature can be set at: 16~30°C (Cooling at room temperature);

(2) If $T_{\text{outdoor ambient temperature}} < [T_{\text{low-temperature cooling temperature}}]$, the temperature can be set at: 25~30°C (Cooling at low temperature), that is, the minimum setting temperature for outer units judgment is 25°C .

(2) Dehumidifying Mode

1. Conditions and processes of dehumidifying operations: Same as the cooling mode;

2. The temperature setting range is: 16~30°C ;

(3) Air-supplying Mode

1. The compressor, outdoor fans and four-way valves are switched off;

2. The temperature setting range is: 16~30°C.

(4) Heating Mode

1. Conditions and processes of heating operations: (T_{indoor ambient temperature} is the actual detection temperature of indoor environment thermo-bulb, T_{heating indoor ambient temperature compensation} is the indoor ambient temperature compensation during heating operations)

(1) If the compressor is shut down, and $[(T_{\text{indoor ambient temperature}} - \Delta T_{\text{heating indoor ambient temperature compensation}}) - T_{\text{set up}}] \leq 0.5^{\circ}\text{C}$, start the machine to enter into heating operations for heating;

(2) During operations of heating, if $0^{\circ}\text{C} \leq [(T_{\text{indoor ambient temperature}} - \Delta T_{\text{heating indoor ambient temperature compensation}}) - T_{\text{set up}}] < 2^{\circ}\text{C}$, the heating operation will be still running;

(3) During operations of heating, if $2^{\circ}\text{C} \leq [(T_{\text{indoor ambient temperature}} - \Delta T_{\text{heating indoor ambient temperature compensation}}) - T_{\text{set up}}]$, the heating operation will stop after reaching the temperature point.

2. The temperature setting range in this mode is: 16~30°C .

3. Special Functions

Defrosting Control

① Conditions for starting defrosting

After the time for defrosting is judged to be satisfied, if the temperature for defrosting is satisfied after detections for continuous 3minutes, the defrosting operation will start.

② Conditions of finishing defrosting

The defrosting operation can exit when any of the conditions below is satisfied:

③ $T_{\text{outdoor pipe temperature}} \geq (T_{\text{outdoor ambient temperature}} - [T_{\text{temperature 1 of finishing defrosting}}])$;

④ The continuous running time of defrosting reaches [tmax. defrosting time].

4. Control Logic

(1) Compressor Control

Start the compressor after starting cooling, heating, dehumidifying operations, and the outer fans start for 5s; When the machine is shutdown, in safety stops and when switching to air-supplying mode, the compressor will stop immediately. In all modes: once the compressor starts up, it will not be allowed to stop until having run for the [tmin. compressor running time] (Note: including cases of shutdown when the temperature point is reached; except the cases requiring stopping the compressor such as fault protection, remote shutdown, mode switching etc.); In all modes: once the compressor stops, it will be allowed be restart after 3-minute delay (Note: The indoor units have a function of power memory, the machine can be restarted after remote shutdown and powering up again without delay).

1. Cooling mode

Start the machine to enter into cooling operation for cooling, the compressor is switched on.

2. Dehumidifying mode

Same as the cooling mode.

3. Air-supplying mode

The compressor is switched off.

4. Heating mode

(1) Start the machine to enter into heating operation for heating, the compressor is switched on.

(2) Defrosting:

a. Defrosting starts: the compressor is shut down, and restarts it after 55-second delay.

b. Defrosting ends: the compressor stops, then starts it after 55-second delay.

(2) Outer Fans Control

Notes:

Only the outer fans run for at least 80s in each air flow speed can the air flow be switched;

After the outer fans run compulsively in high speed for 80s when the machine starts up, control the air flow according to the logic.

After remote shutdown, safety stops, and when the machine stops after reaching the temperature point, as well as after the compressor stops, extend 1 minute, the outer fans will stop (During the period in the 1 minute, the air flow of outer fans can be changed according to the outdoor ambient temperature changes); When running with force, the outdoor fans shall run in the highest air flow.

(3) 4-way valve control

1. The 4-way valve control under the modes of Cooling, dehumidification and supplying air: closing;

2. The status of 4-way valve control under the heating mode: getting power;

(1) 4-way valve power control under heating mode

Starts the machine under heating mode, the 4-way valve will get power immediately.

(2) 4-way valve power turn-off control under heating mode

a. When you should turn off the power or switch to other mode under heating mode, the power of 4-way valve will be cut after 2 minutes of the compressor stopped.

b. When all kinds of protection stops, the power of 4-way valve will be cut after delaying 4 minutes.

(3) Defrosting control under heating mode:

a. Defrosting begins: The power of 4-way valve will be cut after 50s of entering into the defrosting compressor.

b. Defrosting stops: The 4-way valve will get power after 50s of exiting the defrosting compressor.

(4) Evaporator frozen-preventing protection function

At the mode of Cooling, dehumidifying:

Evaporator frozen-preventing protection function is allowed to begin after 6 min of starting the compressor.

1. Starting estimation:

After the compressor stopped working for 180s, if $T_{\text{inner pipe}} > [T_{\text{frozen-preventing frequency-limited temperature}}$ (the temperature of hysteresis is 2 °C), the machine is only allowed to start for operating, otherwise it should not be started, and should be stopped to treat according to the frozen-preventing protection: Clear the trouble under the mode of power turn-off / heating, and the protection times are not counted.

2. Frequency limited

$[T_{\text{frozen-preventing normal speed frequency-reducing temperature}}] \leq T_{\text{inner pipe}} [T_{\text{frozen-preventing frequency-limited temperature}}]$, you should limit the frequency raising of compressor.

3. Reducing frequency at normal speed:

If $[T_{\text{frozen-preventing high speed frequency-reducing temperature}}] \leq T_{\text{inner pipe}} [T_{\text{frozen-preventing normal speed frequency-reducing temperature}}]$, you should adjust the compressor frequency by reducing 8Hz/90s till the lower limit;

4. Reducing frequency at high speed:

If $[T_{\text{frozen-preventing power turn-off temperature}}] \leq T_{\text{inner pipe}} [T_{\text{frozen-preventing high speed frequency-reducing temperature}}]$ you should adjust the compressor frequency by reducing 30Hz/90s till the lower limit;

5. Power turn-off:

If the $T_{\text{inner pipe}} < [T_{\text{frozen-preventing power turn-off temperature}}]$, then frozen-preventing protect to stop the machine; If $[T_{\text{frozen-preventing frequency-limited temperature}}] < T_{\text{inner pipe}}$, and the compressor has stopped working for 3 minutes, the whole machine should be allowed to operate.

6. If the frozen-preventing protection power turn-off continuously occurs for six times, it should not be resumed automatically, and you should press the ON/OFF button to resume if the fault keeps on. During the process of running, if the running time of compressor exceeds the t evaporator frozen-preventing protection times zero clearing time , the times of frozen-preventing power turn-off should be cleared to recount. The mode of stopping the machine or transferring to supply air will clear the trouble times immediately (if the trouble can not be resumed, mode transferring will not clear it).

(5) Overload protection function

Overload protection function at the mode of cooling and dehumidifying

1. Starting estimation:

After the compressor stopped working for 180s, if $T_{\text{outer pipe}} < [T_{\text{cooling overload frequency-limited temperature}}]$ (the temperature of hysteresis is 2°C), the machine is allowed to start, otherwise it should not be started, and should be stopped to treat according to the overload protection: Clear the trouble at the mode of power turn-off / heating, and the protection times are not counted.

2. Frequency limited

If $[T_{\text{cooling overload frequency-limited temperature}}] \leq T_{\text{outer pipe}} [T_{\text{cooling overload frequency reducing temperature at normal speed}}]$, you should limit the frequency raising of compressor.

3. Reducing frequency at normal speed and power turn-off:

If $[T_{\text{cooling overload frequency reducing temperature at high speed}}] \leq T_{\text{outer pipe}} < [T_{\text{cooling overload power turn-off temperature}}]$, you should adjust the compressor frequency by reducing 8Hz/90s till the lower limit; After it was running 90s at the lower limit, if $[T_{\text{cooling overload frequency reducing temperature at normal speed}}] \leq T_{\text{outer pipe}}$, then Cooling overload protects machine stopping;

4. Reducing frequency at high speed and stop machine:

If $[T_{\text{cooling overload frequency reducing temperature at high speed}}] \leq T_{\text{outer pipe}} [T_{\text{cooling overload power turn-off temperature}}]$, you should adjust the compressor frequency by reducing 30Hz/90s till the lower limit; After it was running 90s at the lower limit, if $[T_{\text{cooling overload frequency reducing temperature at normal speed}}] \leq [T_{\text{outer pipe}}]$, then Cooling overload protects machine stopping;

5. Power turn-off:

If the $[T_{\text{cooling overload power turn-off temperature}}] \leq T_{\text{outer pipe}}$, then Cooling overload protects machine stopping; If $[T_{\text{outer pipe}}] < [T_{\text{cooling overload frequency-limited temperature}}]$ and the compressor has been stopped working for 3 minutes, the machine should be allowed to operate.

6. If the Cooling overload protection power turn-off continuously occurs for six times, it should not be resumed automatically, and you should press the ON/OFF button to resume if the fault keeps on. During the process of running, if the running time of compressor exceeds the t overload protection times zero clearing time , the times of overload protection power turn-off should be cleared to recount. The mode of stopping the machine or transferring to supply air will clear the trouble times immediately (if the trouble can not be resumed, transferring mode will not clear it).

Overload protection function at the mode of heating**Starting estimation :**

After the compressor stopped working for 180s, if $T_{\text{inner pipe}} > T_{\text{heating overload frequency-limited temperature}}$ (the temperature of hysteresis is 2 °C), the machine is allowed to start, otherwise it should not be started, and should be stopped to treat according to the overload protection:

Clear the trouble at the mode of power turn-off / heating, and the protection times are not counted.

1. Frequency limited

If $[T_{\text{heating overload frequency-limited temperature}}] \leq T_{\text{inner pipe}} < [T_{\text{heating overload frequency reducing temperature at normal speed}}]$, you should limit the frequency raising of compressor.

2. Reducing frequency at normal speed and stopping machine:

If $T_{\text{heating overload frequency reducing temperature at normal speed}} \leq T_{\text{inner pipe}} < [T_{\text{heating overload frequency reducing temperature at high speed}}]$, you should adjust the compressor frequency by reducing 8Hz/90s till the lower limit; After it was running 90s at the lower limit, if $T_{\text{heating overload frequency reducing temperature at normal speed}} \leq T_{\text{inner pipe}}$, then overload protects machine stopping;

3. Reducing frequency at high speed and power turn-off:

If $[T_{\text{heating overload frequency reducing temperature at high speed}}] \leq T_{\text{inner pipe}} < [T_{\text{heating overload power turn-off temperature}}]$, you should adjust the compressor frequency by reducing 30Hz/90s till the lower limit; After it was running 90s at the lower limit, if $T_{\text{heating overload frequency reducing temperature at normal speed}} \leq T_{\text{outer pipe}}$, then Cooling overload protects machine stopping;

4. Power turn-off:

If the $[T_{\text{heating overload power turn-off temperature}}] \leq T_{\text{inner pipe}}$, then overload protects machine stopping; If $T_{\text{inner pipe}} > T_{\text{heating overload frequency-limited temperature}}$ and the compressor has been stopped working for 3 minutes, the machine should be allowed to operate.

5. If the overload protection power turn-off continuously occurs for six times, it should not be resumed automatically, and you should press the ON/OFF button to resume if the fault keeps on. During the process of running, if the running time of compressor exceeds the $t_{\text{overload protection times zero clearing time}}$, the times of overload protection power turn-off should be cleared to recount. The mode of stopping the machine or transferring to supply air will clear the trouble times immediately (if the trouble can not be resumed, transferring mode will not clear it). Protective function for discharge temperature of compressor

1. Starting estimation:

After the compressor stopped working for 180s, if $T_{\text{Discharge}} < T_{\text{Discharge limited temperature}}$ (the temperature of hysteresis is 2°C), the machine is allowed to start, otherwise it should not be started, and should be stopped to treat according to the discharge temperature:

The machine should be stopped or transferred to supply air, the trouble should be cleared immediately, and the protection times are not counted.

2. Frequency limited

If $[T_{\text{limited frequency temperature during discharging}}] \leq T_{\text{Discharge}} < [T_{\text{frequency reducing temperature at normal speed during discharging}}]$, you should limit the frequency raising of compressor.

3. Reducing frequency at normal speed and stopping machine:

If $[T_{\text{frequency reducing temperature at normal speed during discharging}}] \leq T_{\text{Discharge}} < [T_{\text{frequency reducing temperature at high speed during discharging}}]$, you should adjust the compressor frequency by reducing 8Hz/90s till the lower limit; After it was running 90s at the lower limit, if $[T_{\text{frequency reducing temperature at normal speed during discharging}}] \leq T_{\text{Discharge}}$, you should discharge to protect machine stopping;

4. Reducing frequency at high speed and power turn-off:

If $[T_{\text{frequency reducing temperature at high speed during discharging}}] \leq T_{\text{Discharge}} < [T_{\text{stop temperature during discharging}}]$, you should adjust the compressor frequency by reducing 30Hz/90s till the lower limit; After it was running 90s at the lower limit, if $[T_{\text{frequency reducing temperature at normal speed during discharging}}] \leq T_{\text{Discharge}}$, you should discharge to protect machine stopping;

5. Power turn-off:

If the $[T_{\text{Power turn-off temperature during discharging}}] \leq T_{\text{Discharge}}$, you should discharge to protect machine stopping; If $[T_{\text{Discharge}}] < [T_{\text{limited frequency temperature during discharging}}]$ and the compressor has been stopped for 3 minutes, the machine should be allowed to operate.

6. If the discharging temperature protection of compressor continuously occurs for six times, it should not be resumed automatically, and you should press the ON/OFF button to resume. During the process of running, if the running time of compressor exceeds the $t_{\text{Protection times clearing of discharge}}$, the discharge protection is cleared to recount. Stopped or transferred to supply air mode will clear the trouble times immediately (if the trouble can not be resumed, mode transferring also will not clear it).

7. Frequency limited

If $[I_{\text{limited frequency when overcurrent}}] \leq [I_{\text{AC Electric current}}] < [I_{\text{frequency reducing when overcurrent}}]$, you should limit the frequency raising of compressor.

8. Reducing frequency:

If $[I_{\text{frequency reducing when overcurrent}}] \leq [I_{\text{AC Electric current}}]$, you should reduce the compressor frequency till the lower limit or exit the frequency reducing condition;

9. Power turn-off:

If $[I_{\text{Power turn-off machine when overcurrent}}] \leq [I_{\text{AC Electric current}}]$, you should carry out the overcurrent stopping protection; If $[I_{\text{AC Electric current}}] < [I_{\text{limited frequency when overcurrent}}]$ and the compressor has been stopped for 3 minutes, the machine should be allowed to operate.

10. If the overcurrent protection continuously occurs for six times, it should not be resumed automatically, and you should press the ON/OFF button to resume. During the process of running, if the running time of compressor exceeds the $[t_{\text{Protection times clearing of over current}}]$, the discharge protection is cleared to recount.

(6)Voltage sag protection

After start the compressor, if the time of DC link Voltage sag [$U_{\text{Sagging protection voltage}}$] is measured to be less than $t_{\text{Voltage sag protection time}}$, the machine should be stop at once, hand on the voltage sag trouble, reboot automatically after 30 minutes.

(7)Communication fault

When you have not received any correct signal from the inner machine in three minutes, the machine will stop for communication fault. When you have not received any correct signal from driver IC (aim to the controller for the separating of main control IC and driver IC), and the machine will stop for communication fault. If the communication is resumed, the machine will be allowed to operate.

(8)Module protection

Testing the module protective signal immediately after started, once the module protective signal is measured, stop the machine with module protection immediately. If the module protection is resumed, the machine will be allowed to operate. If the module protection continuously occurs for three times, it should not be resumed automatically, and you should press the ON/OFF button to resume. If the running time of compressor exceeds the [$t_{\text{Protection times clearing of module}}$], the module protection is cleared to recount.

(9)Module overheating protection

1. Starting estimation:

After the compressor stopped working for 180s, if $T_{\text{Module}} < [T_{\text{Module frequency limited temperature}}]$ (the temperature of hysteresis is 2), the machine is allowed to start, otherwise it should not be started, and should be stopped to treat according to the module overheating protection: The machine should be stopped or transferred to supply air, the trouble should be cleared immediately, and the protection times are not counted.

2. Frequency limited

If $[T_{\text{Limited frequency temperature of module}}] \leq T_{\text{Module}} < [T_{\text{frequency reducing temperature at normal speed of module}}]$, you should limit the frequency raising of compressor.

3. Reducing frequency at normal speed and power turn-off:

If $[T_{\text{frequency reducing temperature at normal speed of module}}] \leq T_{\text{Module}} < [T_{\text{frequency reducing temperature at high speed of module}}]$, you should adjust the compressor frequency by reducing 8Hz/90s till the lower limit; After it was running 90s at the lower limit, if $[T_{\text{frequency reducing temperature at normal speed of module}}] \leq T_{\text{Module}}$, you should stop the machine for module overheating protection;

4. Reducing frequency at high speed and power turn-off:

If $[T_{\text{frequency reducing temperature at high speed of module}}] \leq T_{\text{Module}} < [T_{\text{Power turn-off temperature of module}}]$ you should adjust the compressor frequency by reducing 30Hz/90s till the lower limit; After it was running 90s at the lower limit, if $[T_{\text{frequency reducing temperature at normal speed of module}}] \leq T_{\text{Module}}$, you should stop the machine for module overheating protection;

5. Power turn-off:

If the $[T_{\text{Power turn-off temperature of module}}] \leq T_{\text{Module}}$, you should stop the machine for module overheating protection; If $T_{\text{Module}} < [T_{\text{Limited frequency temperature of module}}]$ and the compressor has been stopped for 3 minutes, the machine should be allowed to operate.

6. If protection continuously occurs for six times, it should not be resumed automatically, and you should press the ON/OFF button to resume. During the process of running, if the running time of compressor exceeds the [$t_{\text{Protection times clearing of module}}$], the discharge protection is cleared to recount. Stopped or transferred to supply air mode will clear the trouble times immediately (if the trouble can not be resumed, mode transferring also will not clear it).

(10)Compressor overloads protection

If you measure the compressor overload switch action in 3s, the compressor should be stopped for overloading. The machine should be allowed to operate after overload protection was measured to resume. If the overloading protection continuously occurs for three times, it should not be resumed automatically, and you should press the ON/OFF button to resume. The protection times of compressor is allowed to clear after the compressor run [$t_{\text{Protection times clearing of compressor overloading}}$] 30 minutes.

(11)Phase current overcurrent protection of compressor

During the running process of compressor, you could measure the phase current of the compressor, and control it according to the following steps:

1. Frequency limited

If $[I_{\text{Limited frequency phase current}}] \leq [I_{\text{Phase current T frequency reducing phase current}}]$, you should limit the frequency raising of compressor.

2. Reducing Frequency

If $[I_{\text{Frequency Reducing Phase Current}}] \leq I_{\text{Phase Current}} < [I_{\text{Power Turn-Off Phase Current}}]$, the compressor shall continue to reduce frequency till the lowest frequency limit or out of the condition of reducing frequency;

3. Power turn-off

If $[I_{\text{Phase Current}}] \geq [I_{\text{Power Turn-Off Phase Current}}]$, the compressor phase current shall stop working for overcurrent protection; if $[I_{\text{Phase Current}}] \leq [I_{\text{Frequency Reducing Phase Current}}]$, and the compressor have stopped working for 3 min, the machine shall be allowed to operate;

4. If the overcurrent protection of compressor phase current continuously occurs for six times, it should not be resumed automatically, and you should press the ON/OFF button to resume. During the process of running, if the running time of compressor exceeds the [$t_{\text{Clearing Time of Compressor Phase Current Times}}$], the overcurrent protection is cleared to recount.

(12) Starting-up Failure Protection for Compressor

Stop the compressor after its starting-up fails, restart it after 20s if the fault doesn't show, and if they are all failing for the successive start 3 times, it shall be reported as Starting-up Failure, and then restart up it after 3 min. When it still not be able to operate through carry out the above process for 5 times, it is available if press ON/OFF. And the compressor should be cleared the times after it run 2 min.

(13) Out-of-Step Protection for Compressor

The out-of-step protection signal should be detected immediately after starting-up compressor, and once find the out-of-step protection signal, the out-of-step protection shall be stopped; if it can run for lasting power turn-off 3 min, the machine shall be allowed to operate. If it still can't run automatically when the out-of-step protection for compressor happens to stop working for 6 times in succession, it needs to press ON/OFF to operate. And if the running time is more than 10 min, the power turn-off times for out-of-step protection shall be cleared and recounted.

(14) Voltage Abnormity Protection for DC Bus

To detect voltage abnormity protection for dc bus after completing the pre-charge:

1.Over-High Voltage Protection for DC Bus:

If it found the DCbus voltage $U_{DC} > [U_{DC} \text{ Jiekuangchun Protection}]$, turn off PFC and stop the compressor at once, and it shall show the DC over-high voltage failure; it should clear out the failure when the voltage dropped to $U_{DC} < [U_{DC} \text{ Jiekuangchun Recovery}]$ and the compressor stopped for 3 min.

2.Over-Low Voltage Protection for DC Bus:

If it found the DC bus voltage $U_{DC} < [U_{DC} \text{ Wantuochun Protection}]$, turn off PFC and stop the compressor at once, and it shall show the DC over-low voltage; and it should clear out the failure when the voltage raised to $U_{DC} > [U_{DC} \text{ Wantuochun Recovery}]$ and the compressor stopped for 3 min.

3.To detect voltage abnormity protect for DC bus when getting electricity:

If it found the DC bus voltage $U_{DC} > [U_{DC} \text{—Over-High Voltage}]$, turn off the relay at once, and shows voltage abnormity failure for DC Bus. And the failure can't recover except to break off and get the electricity.

(15)Abnormity Protection for Four-way Valve

Under the model of heating operation in good condition: the compressor is detected $[T_{\text{Inner Tube}} < (T_{\text{Inner Ring}} - T_{\text{Abnormity Temperature Difference For Four-Way Valve Reversion}})]$, during the running, it should be regarded as four-way valve reversion abnormity. And then it can run if stop the reversion abnormity protection for four-way valve 3 min; and if it still can't run when the reversion abnormity protection for four-way valve happens to stop working for 3 times in succession, it is available if presses ON/OFF.

Attention: the protection shall be shielded during the testing mode and defrosting process, and it shall be cleared out the failure and its times immediately when turning off or delivering wind / cooling / dehumidifying mode conversed (the inverted mode don't clear out the failure when it can't recover to operate).

(16) PFC Protection

1. After start up the PFC, it should detect the protection signal of PFC immediately; under the condition of PFC protection, it should turn off the PFC and compressor at one time;
2. It shows the failure is cleared out if PFC Protection stopped working 3 min and recovers to run automatically;
3. If it still can't run when it occurs PFC protection for 3 times in succession, it is available if presses ON/OFF; and clear the PFC Protection times when start up PFC for 10min.

(17) Failure Detection for Sensor

1. Outdoor Ambient Sensor: detect the failure of sensor at all times.
2. Outdoor Tube Sensor: You should not detect the failure of outdoor tube sensor within 10 minutes heating operation compressor except the defrosting, and you could detect it at other time.
3. Outdoor Exhaust Sensor:
 - (a) The compressor only detect the sensor failure after it start up 3 min in normal mode;
 - (b) It should detect the exhaust sensor failure immediately in the testing mode.
4. Module Temperature Sensor:
 - (a) Short-Circuit Detection: the compressor should be detected immediately when the module temperature sensor occurs short-circuits;
 - (b) Open-Circuit Detection: the compressor should be detected on open-circuit when it runs 3min (it needn't 30s avoiding the module over-heated).
 - (c) Detect the sensor failure at all times in the testing mode.
5. Disposal for Sensor Protection
 - (1) When the short-circuit of sensor is detected within 30s, It is regarded as the temperature of sensor over-high (or infinitely high), and now according to the over-high sensor, the machine should carry out the corresponding protection to stop working, and show the corresponding temperature shutdown protection and sensor failure at the same time (for example: the compressor stops immediately when the outdoor tube sensor short-circuit, and the machine shall show the overload protection and outdoor tube sensor failure).
 - (2) When the open-circuit of sensor is detected within 30s, The protection shall be stopped and it shall show the corresponding sensor failure.

6. Electric Heating Function of Chassis

- (1) When $T_{\text{outdoor amb.}} \leq 0^{\circ}\text{C}$, the electric heating of chassis will operate;
- (2) When $T_{\text{outdoor amb.}} > 2^{\circ}\text{C}$, the electric heating of chassis will stop operation;
- (3) When $0^{\circ}\text{C} < T_{\text{outdoor amb.}} \leq 2^{\circ}\text{C}$, the electric heating of chassis will keep original status.

7. Electric Heating Function of Compressor

- (1) When $T_{\text{outdoor amb.}} \leq -5^{\circ}\text{C}$, compressor stops operation, while the electric heating of compressor starts operation;
- (2) When $T_{\text{outdoor amb.}} > -2^{\circ}\text{C}$, the electric heating of compressor stops operation;
- (3) When $-5^{\circ}\text{C} < T_{\text{outdoor amb.}} \leq -2^{\circ}\text{C}$, the electric heating of compressor will keep original status.

Part II : Installation and Maintenance

7. Notes for Installation and Maintenance

Safety Precautions: Important!

Please read the safety precautions carefully before installation and maintenance.

The following contents are very important for installation and maintenance.

Please follow the instructions below.

- The installation or maintenance must accord with the instructions.
- Comply with all national electrical codes and local electrical codes.
- Pay attention to the warnings and cautions in this manual.
- All installation and maintenance shall be performed by distributor or qualified person.
- All electric work must be performed by a licensed technician according to local regulations and the instructions given in this manual.
- Be caution during installation and maintenance. Prohibit incorrect operation to prevent electric shock, casualty and other accidents.



Warnings

Electrical Safety Precautions:

1. Cut off the power supply of air conditioner before checking and maintenance.
2. The air condition must apply specialized circuit and prohibit share the same circuit with other appliances.
3. The air conditioner should be installed in suitable location and ensure the power plug is touchable.
4. Make sure each wiring terminal is connected firmly during installation and maintenance.
5. Have the unit adequately grounded. The grounding wire cant be used for other purposes.
6. Must apply protective accessories such as protective boards, cable-cross loop and wire clip.
7. The live wire, neutral wire and grounding wire of power supply must be corresponding to the live wire, neutral wire and grounding wire of the air conditioner.
8. The power cord and power connection wires cant be pressed by hard objects.
9. If power cord or connection wire is broken, it must be replaced by a qualified person.

10. If the power cord or connection wire is not long enough, please get the specialized power cord or connection wire from the manufacture or distributor. Prohibit prolong the wire by yourself.

11. For the air conditioner without plug, an air switch must be installed in the circuit. The air switch should be all-pole parting and the contact parting distance should be more than 3mm.

12. Make sure all wires and pipes are connected properly and the valves are opened before energizing.

13. Check if there is electric leakage on the unit body. If yes, please eliminate the electric leakage.

14. Replace the fuse with a new one of the same specification if it is burnt down; dont replace it with a cooper wire or conducting wire.

15. If the unit is to be installed in a humid place, the circuit breaker must be installed.

Installation Safety Precautions:

1. Select the installation location according to the requirement of this manual.(See the requirements in installation part)
2. Handle unit transportation with care; the unit should not be carried by only one person if it is more than 20kg.
3. When installing the indoor unit and outdoor unit, a sufficient fixing bolt must be installed; make sure the installation support is firm.
4. Ware safety belt if the height of working is above 2m.
5. Use equipped components or appointed components during installation.
6. Make sure no foreign objects are left in the unit after finishing installation.

Refrigerant Safety Precautions:

1. Avoid contact between refrigerant and fire as it generates poisonous gas; Prohibit prolong the connection pipe by welding.
2. Apply specified refrigerant only. Never have it mixed with any other refrigerant. Never have air remain in the refrigerant line as it may lead to rupture or other hazards.
3. Make sure no refrigerant gas is leaking out when installation is completed.
4. If there is refrigerant leakage, please take sufficient measure to minimize the density of refrigerant.
5. Never touch the refrigerant piping or compressor without wearing glove to avoid scald or frostbite.

Improper installation may lead to fire hazard, explosion, electric shock or injury.

Safety Precautions for Installing and Relocating the Unit:

To ensure safety, please be mindful of the following precautions.



Warnings

1. When installing or relocating the unit, be sure to keep the refrigerant circuit free from air or substances other than the specified refrigerant.

Any presence of air or other foreign substance in the refrigerant circuit will cause system pressure rise or compressor rupture, resulting in injury.

2. When installing or moving this unit, do not charge the refrigerant which is not comply with that on the nameplate or unqualified refrigerant.

Otherwise, it may cause abnormal operation, wrong action, mechanical malfunction or even series safety accident.

3. When refrigerant needs to be recovered during relocating or repairing the unit, be sure that the unit is running in cooling mode. Then, fully close the valve at high pressure side (liquid valve). About 30-40 seconds later, fully close the valve at low pressure side (gas valve), immediately stop the unit and disconnect power. Please note that the time for refrigerant recovery should not exceed 1 minute.

If refrigerant recovery takes too much time, air may be sucked in and cause pressure rise or compressor rupture, resulting in injury.

4. During refrigerant recovery, make sure that liquid valve and gas valve are fully closed and power is disconnected before detaching the connection pipe.

If compressor starts running when stop valve is open and connection pipe is not yet connected, air will be sucked in and cause pressure rise or compressor rupture, resulting in injury.

5. When installing the unit, make sure that connection pipe is securely connected before the compressor starts running.

If compressor starts running when stop valve is open and connection pipe is not yet connected, air will be sucked in and cause pressure rise or compressor rupture, resulting in injury.

6. Prohibit installing the unit at the place where there may be leaked corrosive gas or flammable gas.

If there leaked gas around the unit, it may cause explosion and other accidents.

7. Do not use extension cords for electrical connections. If the electric wire is not long enough, please contact a local service center authorized and ask for a proper electric wire.

Poor connections may lead to electric shock or fire.

8. Use the specified types of wires for electrical connections between the indoor and outdoor units. Firmly clamp the wires so that their terminals receive no external stresses.

Electric wires with insufficient capacity, wrong wire connections and insecure wire terminals may cause electric shock or fire.

Safety Precautions for Refrigerant

● To realize the function of the air conditioner unit, a special refrigerant circulates in the system. The used refrigerant is the fluoride R32, which is specially cleaned. The refrigerant is flammable and inodorous. Furthermore, it can lead to explosion under certain conditions. But the flammability of the refrigerant is very low. It can be ignited only by fire.

● Compared to common refrigerants, R32 is a nonpolluting refrigerant with no harm to the ozoneosphere. The influence upon the greenhouse effect is also lower. R32 has got very good thermodynamic features which lead to a really high energy efficiency. The units therefore need a less filling.

WARNING:

● Do not use means to accelerate the defrosting process or to clean, other than those recommended by the manufacture.

Should repair be necessary, contact your nearest authorized Service Centre. Any repairs carried out by unqualified personnel may be dangerous. The appliance shall be stored in a room without continuously operating ignition sources. (for example: open flames, an operating gas appliance or an operating electric heater.)

● Do not pierce or burn.

● Appliance shall be installed, operated and stored in a room with a floor area larger than 4m (or 6m).

● Appliance filled with flammable gas R32. For repairs, strictly follow manufacturers instructions only. Be aware that refrigerants not contain odour.

● Read specialists manual.

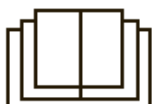

Safety Operation of Flammable Refrigerant

Qualification requirement for installation and maintenance man

- All the work men who are engaging in the refrigeration system should bear the valid certification awarded by the authoritative organization and the qualification for dealing with the refrigeration system recognized by this industry. If it needs other technician to maintain and repair the appliance, they should be supervised by the person who bears the qualification for using the flammable refrigerant.
- It can only be repaired by the method suggested by the equipments manufacturer.

Installation notes

- The air conditioner is not allowed to use in a room that has running fire (such as fire source, working coal gas ware, operating heater).
 - It is not allowed to drill hole or burn the connection pipe.
 - The air conditioner must be installed in a room that is larger than the minimum room area.
- The minimum room area is shown on the nameplate or following table a.
- Leak test is a must after installation.

table a - Minimum room area(m²)

Minimum room area(m ²)	Charge amount (kg)	≤1.2	1.3	1.4	1.5	1.6	1.7	1.8	1.9	2	2.1	2.2	2.3	2.4	2.5
	floor location	/	14.5	16.8	19.3	22	24.8	27.8	31	34.3	37.8	41.5	45.4	49.4	53.6
wall mounted	/	5.2	6.1	7	7.9	8.9	10	11.2	12.4	13.6	15	16.3	17.8	19.3	
window mounted	/	1.6	1.9	2.1	2.4	2.8	3.1	3.4	3.8	4.2	4.6	5	5.5	6	
ceiling mounted	/	1.1	1.3	1.4	1.6	1.8	2.1	2.3	2.6	2.8	3.1	3.4	3.7	4	

Maintenance notes

- Check whether the maintenance area or the room area meet the requirement of the nameplate.
 - Its only allowed to be operated in the rooms that meet the requirement of the nameplate.
- Check whether the maintenance area is well-ventilated.
 - The continuous ventilation status should be kept during the operation process.
- Check whether there is fire source or potential fire source in the maintenance area.
 - The naked flame is prohibited in the maintenance area; and the “no smoking” warning board should be hanged.
- Check whether the appliance mark is in good condition.
 - Replace the vague or damaged warning mark.

Welding

- If you should cut or weld the refrigerant system pipes in the process of maintaining, please follow the steps as below:
 - a. Shut down the unit and cut power supply
 - b. Eliminate the refrigerant
 - c. Vacuuming
 - d. Clean it with N2 gas
 - e. Cutting or welding
 - f. Carry back to the service spot for welding
- Make sure that there isnt any naked flame near the outlet of the vacuum pump and its well-ventilated.
- The refrigerant should be recycled into the specialized storage tank.

Filling the refrigerant

- Use the refrigerant filling appliances specialized for R32. Make sure that different kinds of refrigerant wont contaminate with each other.
- The refrigerant tank should be kept upright at the time of filling refrigerant.
- Stick the label on the system after filling is finished (or havent finished).
- Dont overfilling.
- After filling is finished, please do the leakage detection before test running; another time of leak detection should be done when its removed.

Safety instructions for transportation and storage

- Please use the flammable gas detector to check before unload and open the container.
- No fire source and smoking.
- According to the local rules and laws.

Main Tools for Installation and Maintenance

<p>1. Level meter, measuring tape</p> 	<p>2. Screw driver</p> 	<p>3. Impact drill, drill head, electric drill</p> 
<p>4. Electroprobe</p> 	<p>5. Universal meter</p> 	<p>6. Torque wrench, open-end wrench, inner hexagon spanner</p> 
<p>7. Electronic leakage detector</p> 	<p>8. Vacuum pump</p> 	<p>9. Pressure meter</p> 
<p>10. Pipe pliers, pipe cutter</p> 	<p>11. Pipe expander, pipe bender</p> 	<p>12. Soldering appliance, refrigerant container</p> 

8. Installation

8.1 Installation Dimension Diagram

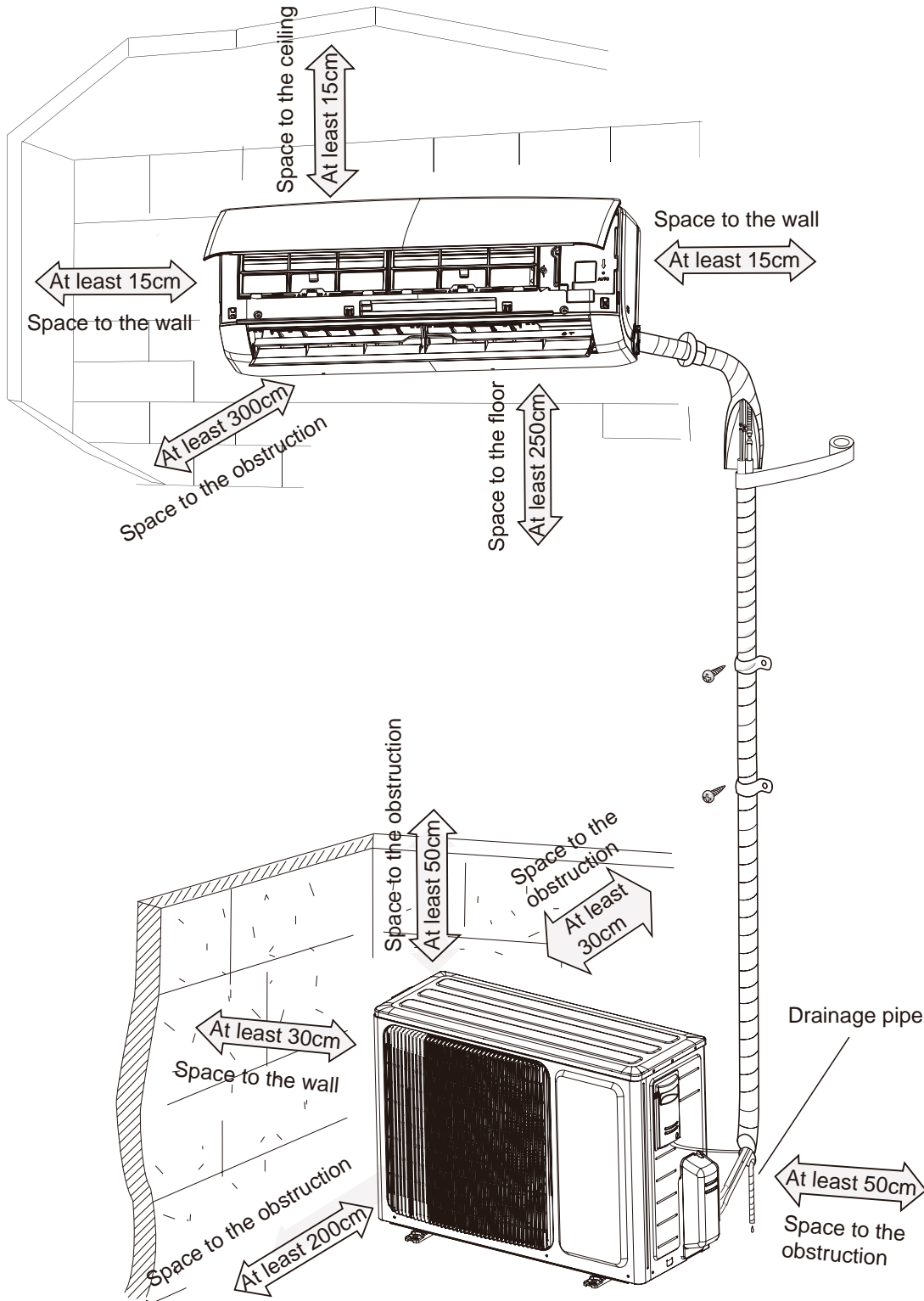

Installation procedures

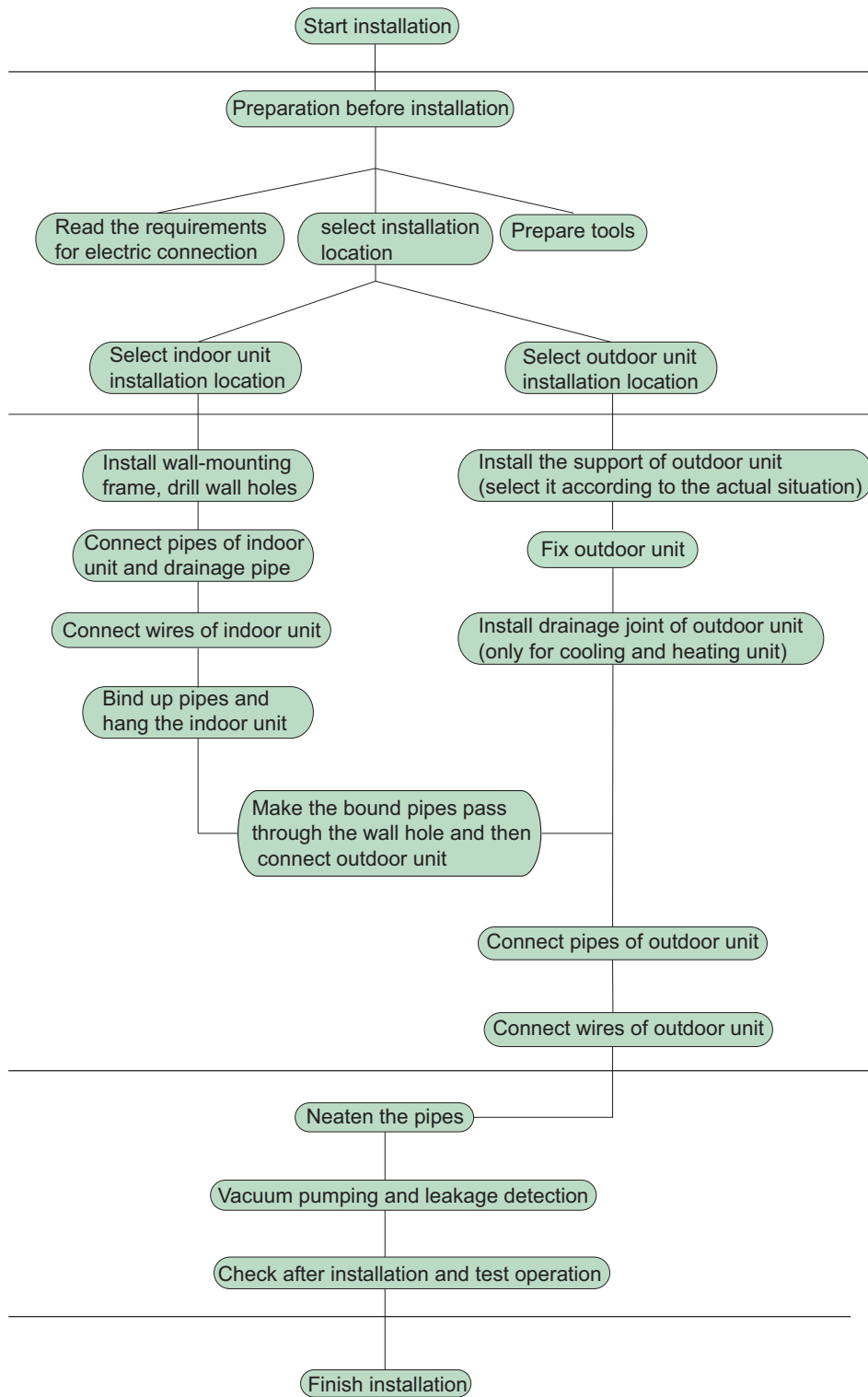

Note: this flow is only for reference; please find the more detailed installation steps in this section.

8.2 Installation Parts-checking

No.	Name	No.	Name
1	Indoor unit	8	Sealing gum
2	Outdoor unit	9	Wrapping tape
3	Connection pipe	10	Support of outdoor unit
4	Drainage pipe	11	Fixing screw
5	Wall-mounting frame	12	Drainage plug(cooling and heating unit)
6	Connecting cable(power cord)	13	Owners manual, remote controller
7	Wall pipe		

⚠ Note:

1. Please contact the local agent for installation.
2. Dont use unqualified power cord.

8.3 Selection of Installation Location

1. Basic Requirement:

Installing the unit in the following places may cause malfunction. If it is unavoidable, please consult the local dealer:

- (1) The place with strong heat sources, vapors, flammable or explosive gas, or volatile objects spread in the air.
- (2) The place with high-frequency devices (such as welding machine, medical equipment).
- (3) The place near coast area.
- (4) The place with oil or fumes in the air.
- (5) The place with sulfured gas.
- (6) Other places with special circumstances.
- (7) The appliance shall not be installed in the laundry.

2. Indoor Unit:

- (1) There should be no obstruction near air inlet and air outlet.
- (2) Select a location where the condensation water can be dispersed easily and wont affect other people.
- (3) Select a location which is convenient to connect the outdoor unit and near the power socket.
- (4) Select a location which is out of reach for children.
- (5) The location should be able to withstand the weight of indoor unit and wont increase noise and vibration.
- (6) The appliance must be installed 2.5m above floor.
- (7) Dont install the indoor unit right above the electric appliance.
- (8) Please try your best to keep way from fluorescent lamp.

3. Outdoor Unit:

- (1) Select a location where the noise and outflow air emitted by the outdoor unit will not affect neighborhood.
- (2) The location should be well ventilated and dry, in which the outdoor unit wont be exposed directly to sunlight or strong wind.
- (3) The location should be able to withstand the weight of outdoor unit.
- (4) Make sure that the installation follows the requirement of installation dimension diagram.
- (5) Select a location which is out of reach for children and far away from animals or plants. If it is unavoidable, please add fence for safety purpose.

8.4 Electric Connection Requirement

1. Safety Precaution

- (1) Must follow the electric safety regulations when installing the unit.
- (2) According to the local safety regulations, use qualified power supply circuit and air switch.
- (3) Make sure the power supply matches with the requirement of air conditioner. Unstable power supply or incorrect wiring may result in electric shock, fire hazard or malfunction. Please install proper power supply cables before using the air conditioner.

Air-conditioner	Air switch capacity
15K	13A
18/24K	16A

- (4) Properly connect the live wire, neutral wire and grounding wire of power socket.
- (5) Be sure to cut off the power supply before proceeding any work related to electricity and safety.
- (6) Do not put through the power before finishing installation.
- (7) If the supply cord is damaged, it must be replaced by the manufacturer, its service agent or similarly qualified persons in order to avoid a hazard.
- (8) The temperature of refrigerant circuit will be high, please keep the interconnection cable away from the copper tube.
- (9) The appliance shall be installed in accordance with national wiring regulations.
- (10) Appliance shall be installed, operated and stored in a room with a floor area larger than 4m.



Please notice that the unit is filled with flammable gas R32. Inappropriate treatment of the unit involves the risk of severe damages of people and material. Details to this refrigerant are found in chapter "refrigerant".

2. Grounding Requirement:

- (1) The air conditioner is first class electric appliance. It must be properly grounding with specialized grounding device by a professional. Please make sure it is always grounded effectively, otherwise it may cause electric shock.
- (2) The yellow-green wire in air conditioner is grounding wire, which cant be used for other purposes.
- (3) The grounding resistance should comply with national electric safety regulations.
- (4) The appliance must be positioned so that the plug is accessible.
- (5) An all-pole disconnection switch having a contact separation of at least 3mm in all poles should be connected in fixed wiring.
- (6) Including an air switch with suitable capacity, please note the following table. Air switch should be included magnet buckle and heating buckle function, it can protect the circuit-short and overload. (Caution: please do not use the fuse only for protect the circuit)

8.5 Installation of Indoor Unit

1. Choosing Installation location

Recommend the installation location to the client and then confirm it with the client.

2. Install Wall-mounting Frame

- (1) Hang the wall-mounting frame on the wall; adjust it in horizontal position with the level meter and then point out the screw fixing holes on the wall.

(2) Drill the screw fixing holes on the wall with impact drill (the specification of drill head should be the same as the plastic expansion particle) and then fill the plastic expansion particles in the holes.

(3) Fix the wall-mounting frame on the wall with tapping screws (ST4.2X25TA) and then check if the frame is firmly installed by pulling the frame. If the plastic expansion particle is loose, please drill another fixing hole nearby.

3. Install Wall-mounting Frame

(1) Choose the position of piping hole according to the direction of outlet pipe. The position of piping hole should be a little lower than the wall-mounted frame. (As show in Fig.1)

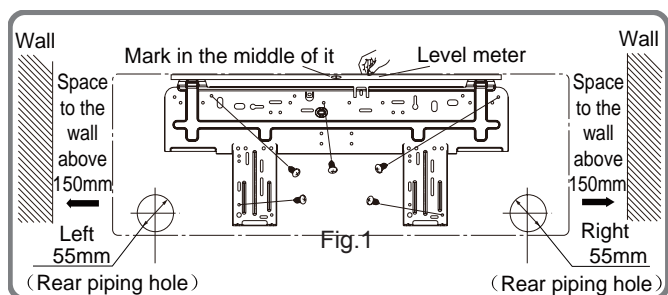

(2) Open a piping hole with the diameter of $\Phi 55\text{mm}$ on the selected outlet pipe position. In order to drain smoothly, slant the piping hole on the wall slightly downward to the outdoor side with the gradient of $5\text{-}10^\circ$. (As show in Fig.2)

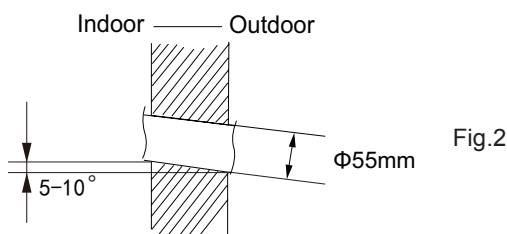

⚠ Note:

- (1) Pay attention to dust prevention and take relevant safety measures when opening the hole.
- (2) The plastic expansion particles are not provided and should be bought locally.

4. Outlet Pipe

(1) The pipe can be led out in the direction of right, rear right, left or rear left. (As show in Fig.3)

(2) When selecting leading out the pipe from left or right, please cut off the corresponding hole on the bottom case. (As show in Fig.4)

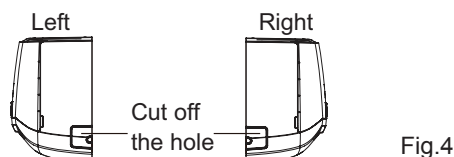
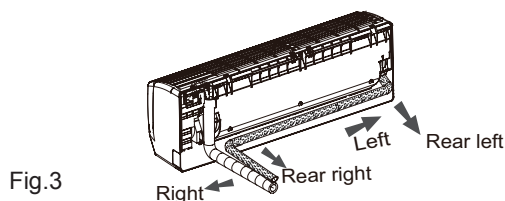

5. Connect the Pipe of Indoor Unit

(1) Aim the pipe joint at the corresponding bellmouth. (As show in Fig.5)

(2) Pretightening the union nut with hand.

(3) Adjust the torque force by referring to the following sheet. Place the open-end wrench on the pipe joint and place the torque wrench on the union nut. Tighten the union nut with torque wrench. (As show in Fig.6)

(4) Wrap the indoor pipe and joint of connection pipe with insulating pipe, and then wrap it with tape. (As show in Fig.7)

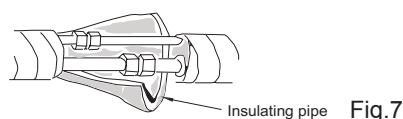
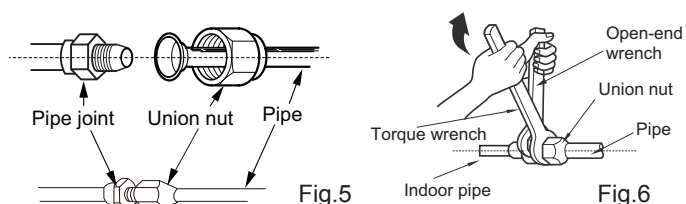

Refer to the following table for wrench moment of force:

Hex nut diameter(mm)	Tightening torque(N·m)
$\Phi 6$	15~20
$\Phi 9.52$	30~40
$\Phi 12$	45~55
$\Phi 16$	60~65
$\Phi 19$	70~75

6. Install Drain Hose

(1) Connect the drain hose to the outlet pipe of indoor unit. (As show in Fig.8)

(2) Bind the joint with tape. (As show in Fig.9)

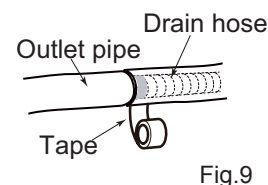
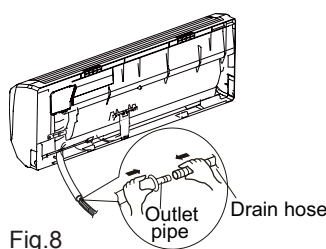

⚠ Note:

- (1) Add insulating pipe in the indoor drain hose in order to prevent condensation.
- (2) The plastic expansion particles are not provided. (As show in Fig.10)

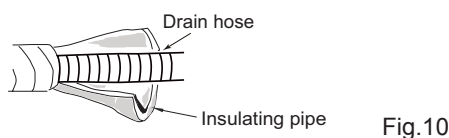

7. Connect Wire of Indoor Unit

(1) Open the panel, remove the screw on the wiring cover and then take down the cover.(As show in Fig.11)

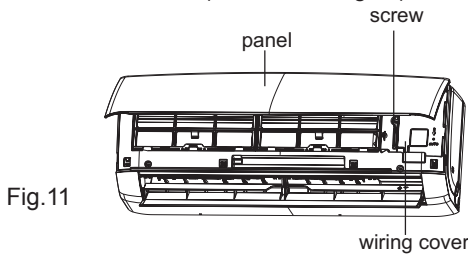

(2) Make the power connection wire go through the cable-cross hole at the back of indoor unit and then pull it out from the front side.(As show in Fig.12)

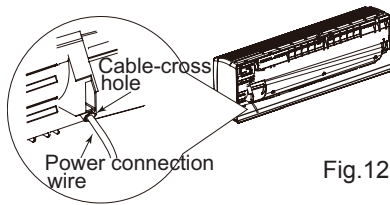

(3) Remove the wire clip; connect the power connection wiresignal control wire (only for cooling and heating unit) to the wiring terminal according to the color; tighten the screw and then fix the power connection wire with wire clip.(As show in Fig.13)

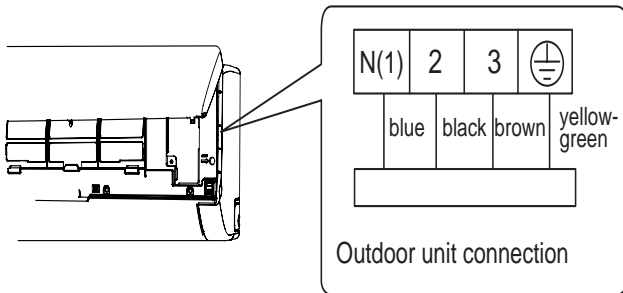

Note: the wiring board is for reference only,please refer to the actual one.

Fig.13

(4) Put wiring cover back and then tighten the screw.
(5) Close the panel.

⚠ Note:

- (1) All wires of indoor unit and outdoor unit should be connected by a professional.
- (2) If the length of power connection wire is insufficient, please contact the supplier for a new one. Avoid extending the wire by yourself.
- (3) For the air conditioner with plug, the plug should be reachable after finishing installation.
- (4) For the air conditioner without plug, an air switch must be installed in the line. The air switch should be all-pole parting and the contact parting distance should be more than 3mm.

8. Bind up Pipe

- (1) Bind up the connection pipe, power cord and drain hose with the band.(As show in Fig.14)
- (2) Reserve a certain length of drain hose and power cord for installation when binding them. When binding to a certain degree, separate the indoor power and then separate the drain hose.(As show in Fig.15)
- (3) Bind them evenly.
- (4) The liquid pipe and gas pipe should be bound separately at the end.

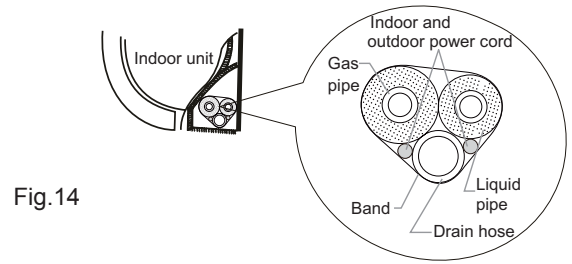

Fig.14

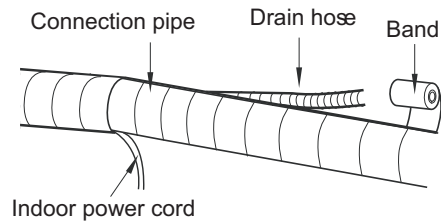

Fig.15

⚠ Note:

- (1) The power cord and control wire cant be crossed or winding.
- (2) The drain hose should be bound at the bottom.

9. Hang the Indoor Unit

- (1) Put the bound pipes in the wall pipe and then make them pass through the wall hole.
- (2) Hang the indoor unit on the wall-mounting frame.
- (3) Stuff the gap between pipes and wall hole with sealing gum.
- (4) Fix the wall pipe.(As show in Fig.16)
- (5) Check if the indoor unit is installed firmly and closed to the wall.(As show in Fig.17)

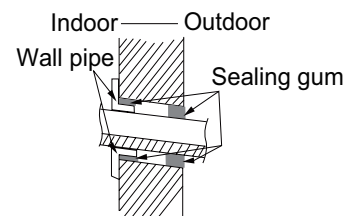

Fig.16

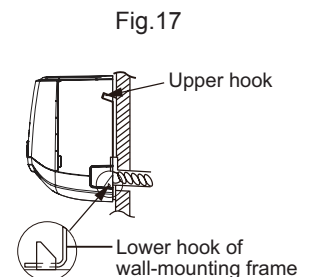

Fig.17

⚠ Note:

Do not bend the drain hose too excessively in order to prevent blocking.

8.6 Installation of Outdoor unit

1. Fix the Support of Outdoor Unit(Select it according to the actual installation situation)

- (1) Select installation location according to the house structure.
- (2) Fix the support of outdoor unit on the selected location with expansion screws.

⚠ Note:

- (1) Take sufficient protective measures when installing the outdoor unit.
- (2) Make sure the support can withstand at least four times the unit weight.
- (3) The outdoor unit should be installed at least 3cm above the floor in order to install drain joint.(As show in Fig.18)
- (4) For the unit with cooling capacity of 2300W~5000W, 6 expansion screws are needed; for the unit with cooling capacity of 6000W~8000W, 8 expansion screws are needed; for the unit with cooling capacity of 10000W~16000W, 10 expansion screws are needed.

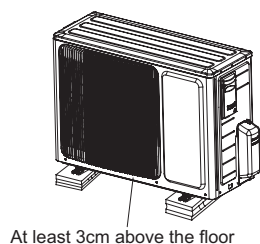

Fig.18

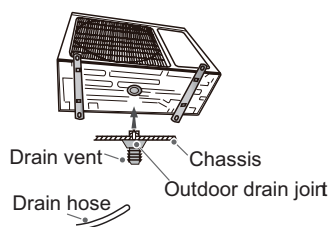

Fig.19

2. Install Drain Joint(Only for cooling and heating unit)

- (1) Connect the outdoor drain joint into the hole on the chassis.
 - (2) Connect the drain hose into the drain vent.
- (As show in Fig.19)

3. Fix Outdoor Unit

- (1) Place the outdoor unit on the support.
 - (2) Fix the foot holes of outdoor unit with bolts.
- (As show in Fig.20)

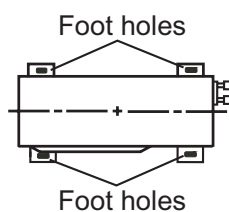

Fig.20

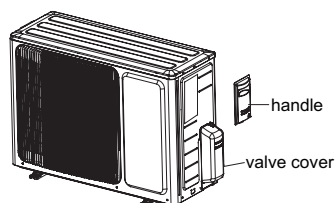

Fig.21

4. Connect Indoor and Outdoor Pipes

- (1) Remove the screw on the right handle of outdoor unit and then remove the handle.(As show in Fig.21)
- (2) Remove the screw cap of valve and aim the pipe joint at the bellmouth of pipe.(As show in Fig.22)

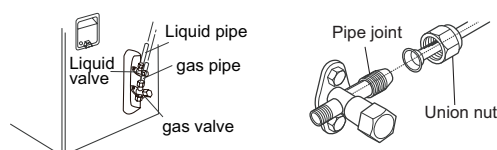

Fig.22

- (3) Pretightening the union nut with hand.
- (4) Tighten the union nut with torque wrench .

Refer to the following table for wrench moment of force:

Hex nut diameter(mm)	Tightening torque(N·m)
Φ6	15~20
Φ9.52	30~40
Φ12	45~55
Φ16	60~65
Φ19	70~75

5. Connect Outdoor Electric Wire

- (1) Remove the wire clip; connect the power connection wire and signal control wire (only for cooling and heating unit) to the wiring terminal according to the color; fix them with screws.(As show in Fig.23)

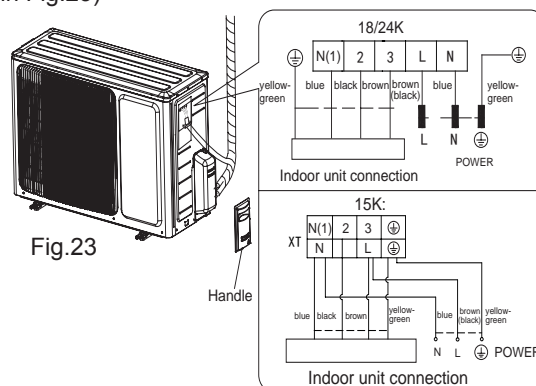

Fig.23

Note: the wiring connect is for reference only,please refer to the actual one.

- (2) Fix the power connection wire and signal control wire with wire clip (only for cooling and heating unit).

⚠ Note:

- (1) After tightening the screw, pull the power cord slightly to check if it is firm.
- (2) Never cut the power connection wire to prolong or shorten the distance.

6. Neaten the Pipes

- (1) The pipes should be placed along the wall, bent reasonably and hidden possibly. Min. semidiameter of bending the pipe is 10cm.
- (2) If the outdoor unit is higher than the wall hole, you must set a U-shaped curve in the pipe before pipe goes into the room, in order to prevent rain from getting into the room.(As show in Fig.24)

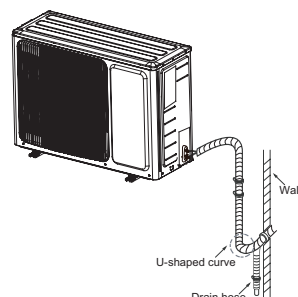

Fig.24

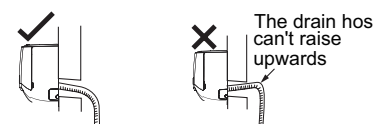

Fig.25

⚠ Note:

- (1) The through-wall height of drain hose shouldnt be higher than the outlet pipe hole of indoor unit.(As show in Fig.25)
- (2) Slant the drain hose slightly downwards. The drain hose cant be curved, raised and fluctuant, etc.(As show in Fig.26)

(3) The water outlet can't be placed in water in order to drain smoothly.(As show in Fig.27)

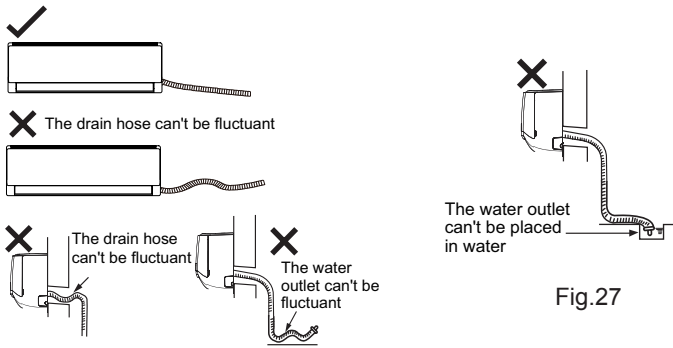

Fig.26

Fig.27

8.7 Vacuum Pumping and Leak Detection

1. Use Vacuum Pump

- (1) Remove the valve caps on the liquid valve and gas valve and the nut of refrigerant charging vent.
- (2) Connect the charging hose of piezometer to the refrigerant charging vent of gas valve and then connect the other charging hose to the vacuum pump.
- (3) Open the piezometer completely and operate for 10-15min to check if the pressure of piezometer remains in -0.1MPa.
- (4) Close the vacuum pump and maintain this status for 1-2min to check if the pressure of piezometer remains in -0.1MPa. If the pressure decreases, there may be leakage.
- (5) Remove the piezometer, open the valve core of liquid valve and gas valve completely with inner hexagon spanner.
- (6) Tighten the screw caps of valves and refrigerant charging vent.(As show in Fig.28)

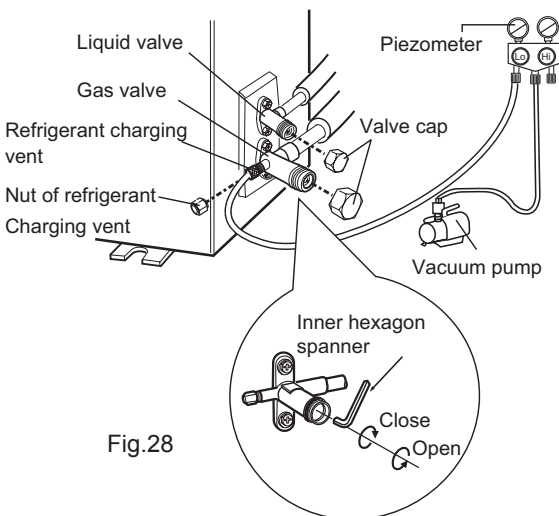

Fig.28

2. Leakage Detection

- (1) With leakage detector:
Check if there is leakage with leakage detector.
- (2) With soap water:
If leakage detector is not available, please use soap water for leakage detection. Apply soap water at the suspected position and keep the soap water for more than 3min. If there are air bubbles coming out of this position, there's a leakage.

8.8 Check after Installation and Test operation

1. Check after Installation

Check according to the following requirement after finishing installation.

NO.	Items to be checked	Possible malfunction
1	Has the unit been installed firmly?	The unit may drop, shake or emit noise.
2	Have you done the refrigerant leakage test?	It may cause insufficient cooling (heating) capacity.
3	Is heat insulation of pipeline sufficient?	It may cause condensation and water dripping.
4	Is water drained well?	It may cause condensation and water dripping.
5	Is the voltage of power supply according to the voltage marked on the nameplate?	It may cause malfunction or damage the parts.
6	Is electric wiring and pipeline installed correctly?	It may cause malfunction or damage the parts.
7	Is the unit grounded securely?	It may cause electric leakage.
8	Does the power cord follow the specification?	It may cause malfunction or damage the parts.
9	Is there any obstruction in air inlet and air outlet?	It may cause insufficient cooling (heating) capacity.
10	The dust and sundries caused during installation are removed?	It may cause malfunction or damaging the parts.
11	The gas valve and liquid valve of connection pipe are open completely?	It may cause insufficient cooling (heating) capacity.
12	Is the inlet and outlet of piping hole been covered?	It may cause insufficient cooling (heating) capacity or waster eletricity.

2. Test Operation

- (1) Preparation of test operation
 - The client approves the air conditioner installation.
 - Specify the important notes for air conditioner to the client.
- (2) Method of test operation
 - Put through the power, press ON/OFF button on the remote controller to start operation.
 - Press MODE button to select AUTO, COOL, DRY, FAN and HEAT to check whether the operation is normal or not.
 - If the ambient temperature is lower than 16°C , the air conditioner cant start cooling.

9. Maintenance

9.1 Malfunction Display of Indoor Unit

1. Malfunction display requirement

When there are several malfunctions, they will be displayed circularly.

2. Malfunction display method

(1) Hardware malfunction: immediate display; refer to “malfunction display table”;

(2) Operation state: immediate display; refer to “malfunction display table”;

(3) Other malfunctions: it is displayed after the compressor stops for 200s; refer to “malfunction display table”.

Note: when the compressor is restarted, the malfunction display delay time (200s) is cleared.

(4) When the unit is under limit frequency or frequency drop state, the display can be controlled via remote controller.

3. Display control via remote controller

Enter display control: press light button successively for 6 times within 3s to display the corresponding malfunction code;

Exit display control: pressing light button successively for 6 times within 3s or after display is shown for 5min, the display will terminate.

Display under test state

Dual 8 nixie tube display: minimum cooling (heating)-P0; middle cooling (heating)-P3

Nominal cooling (heating) –P1; maximum cooling (heating) –P2;

•Error Code List

Malfunction Name	Dual-8 Nixie Tube
Malfunction of jumper cap	C5
No feedback from indoor units motor	H6
Circuit malfunction of zero crossing detection	U8
Indoor ambient temperature sensor is open/short-circuited	F1
Indoor evaporator temperature sensor is open/short-circuited	F2
Module temperature sensor is open/short-circuited	P7
Outdoor ambient temperature sensor is open/short-circuited	F3
Outdoor condenser tube temperature sensor is open/short-circuited	F4
Outdoor discharge temperature sensor is open/short-circuited	F5
Communication malfunction between indoor and outdoor units	E6
Malfunction of phase current circuit detection for compressor	U1
Module temperature protection	P8
Charging malfunction of capacitor	PU
Overload protection of compressor	H3
Freon recovery mode	Fo
Failure start-up of compressor	LC
Discharge high-temperature protection of compressor	E4
Overload protection	E8
Overcurrent protection of the complete unit	E5
Overcurrent protection of phase current	P5
Desynchronizing of compressor	H7
Module current protection (IPM protection)	H5
Low voltage protection of DC bus bar	PL
High voltage protection of DC bus bar	PH
PFC protection	HC
Limit/decrease frequency due to current protection of the complete unit	F8
Limit/decrease frequency due to module current protection (phase current)	En
Limit/decrease frequency due to discharge	F9
Limit/decrease frequency due to freeze protection	FH
Limit/decrease frequency due to overload	F6
Limit/decrease frequency due to module temperature protection	EU
Cold air prevention protection	E9
Freeze protection	E2
Malfunction of ODU DC fan	L3
Malfunction of detecting plate(WIFI)	JF

Note: Please refer to service manual for the troubleshooting procedure for outdoor unit.

9.2 Procedure of Troubleshooting

Indoor unit

(1) Malfunction of Temperature Sensor F1, F2

Main detection points:

- Is the wiring terminal between the temperature sensor and the controller loosened or poorly contacted?
- Is there short circuit due to trip-over of the parts?
- Is the temperature sensor broken?
- Is mainboard broken?

Malfunction diagnosis process:

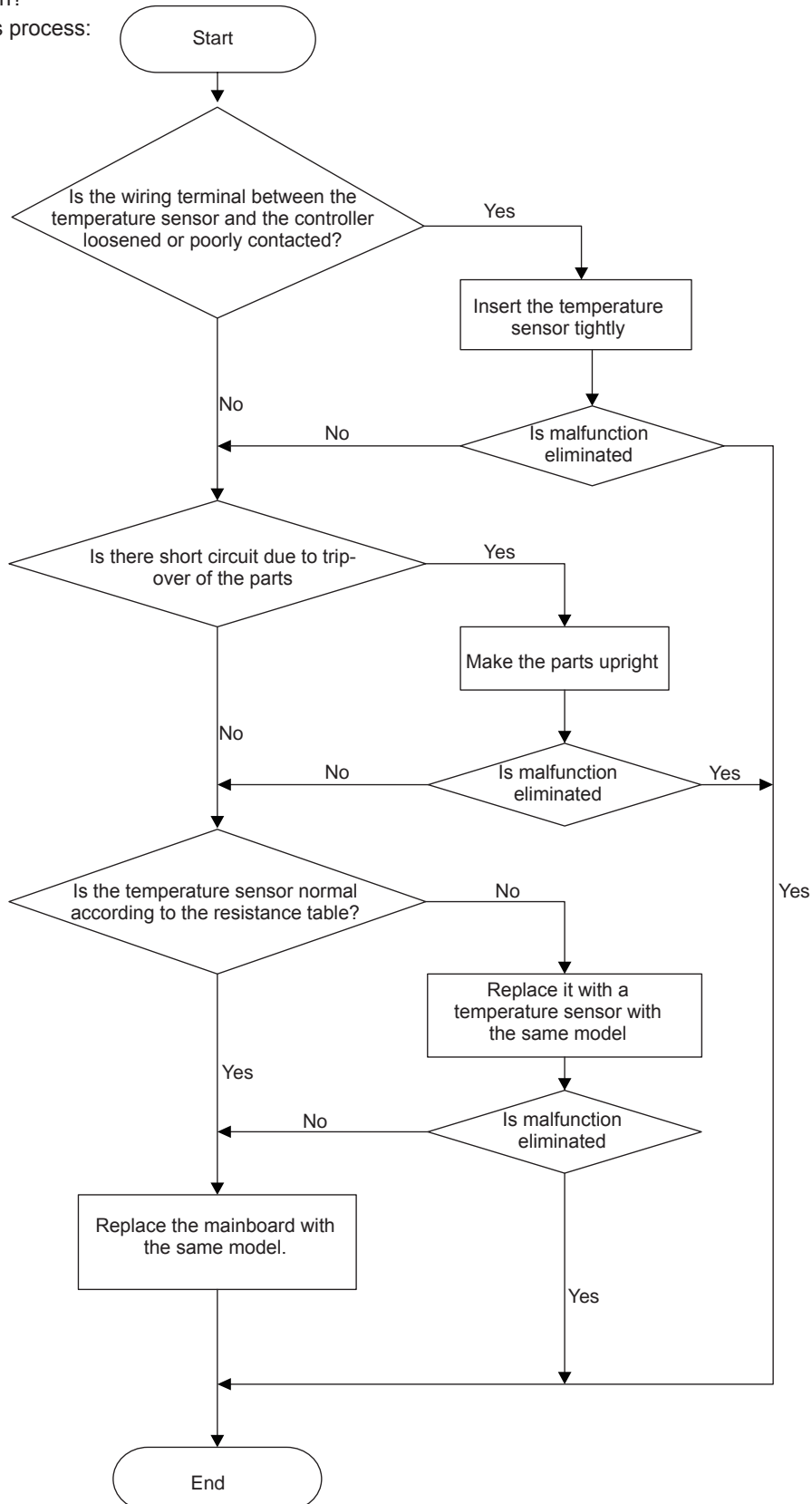

(3) Malfunction of Protection of Jumper Cap C5

Main detection points:

- Is there jumper cap on the mainboard?
- Is the jumper cap inserted correctly and tightly?
- The jumper is broken?
- The motor is broken?
- Detection circuit of the mainboard is defined abnormal?

Malfunction diagnosis process:

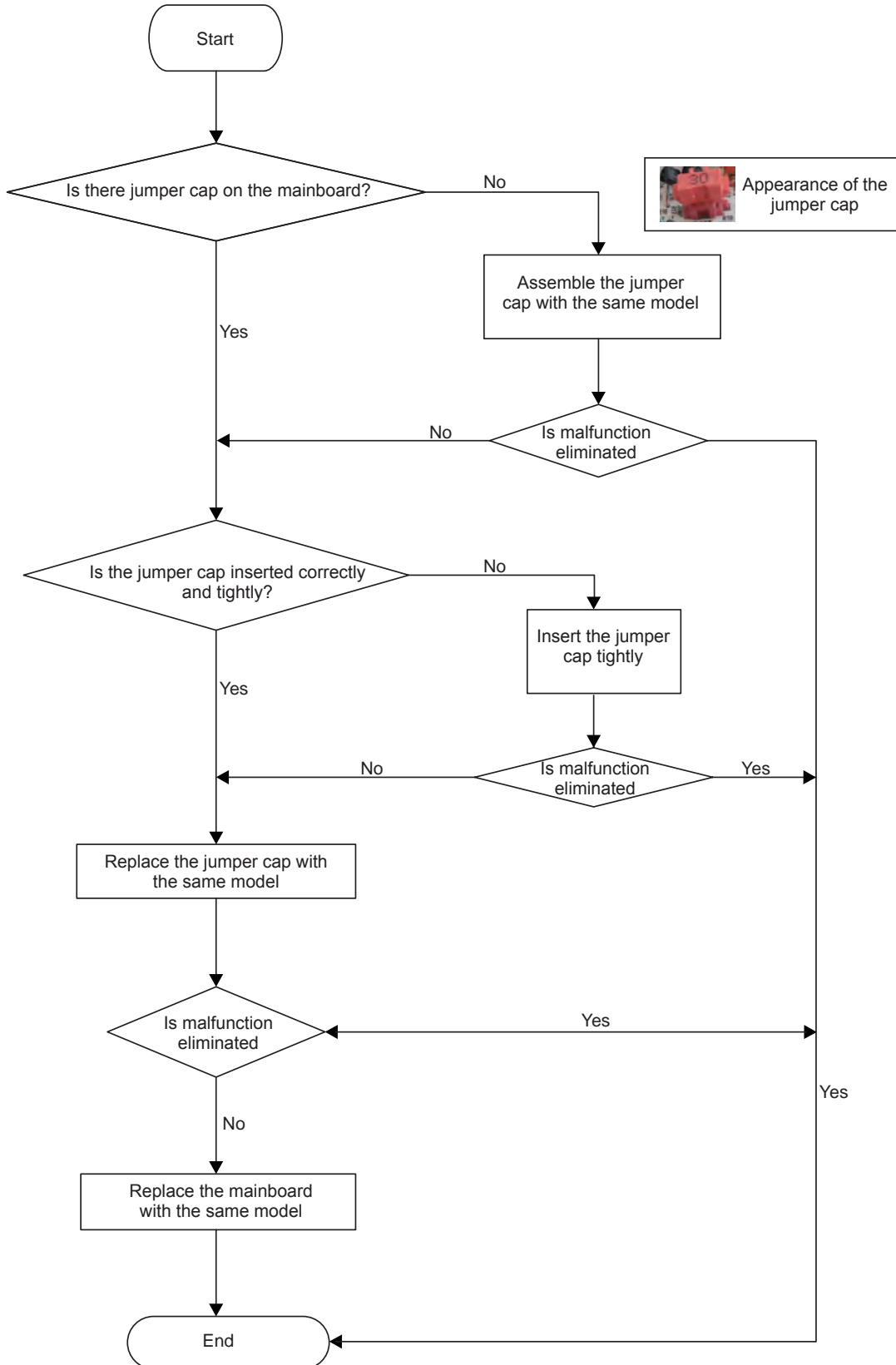

(4) Malfunction of Zero-crossing Inspection Circuit Malfunction of the IDU Fan Motor U8

Main detection points:

- Instant energization after de-energization while the capacitor discharges slowly?
- The zero-cross detection circuit of the mainboard is defined abnormal?

Malfunction diagnosis process:

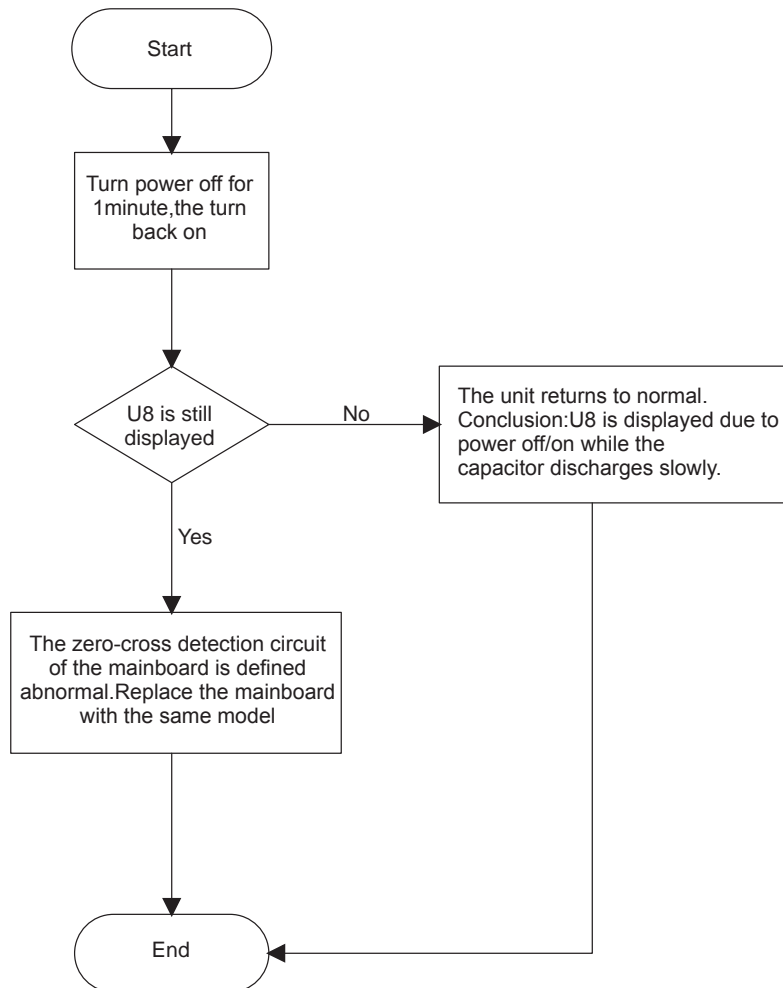

(5) Communication malfunction (E6)

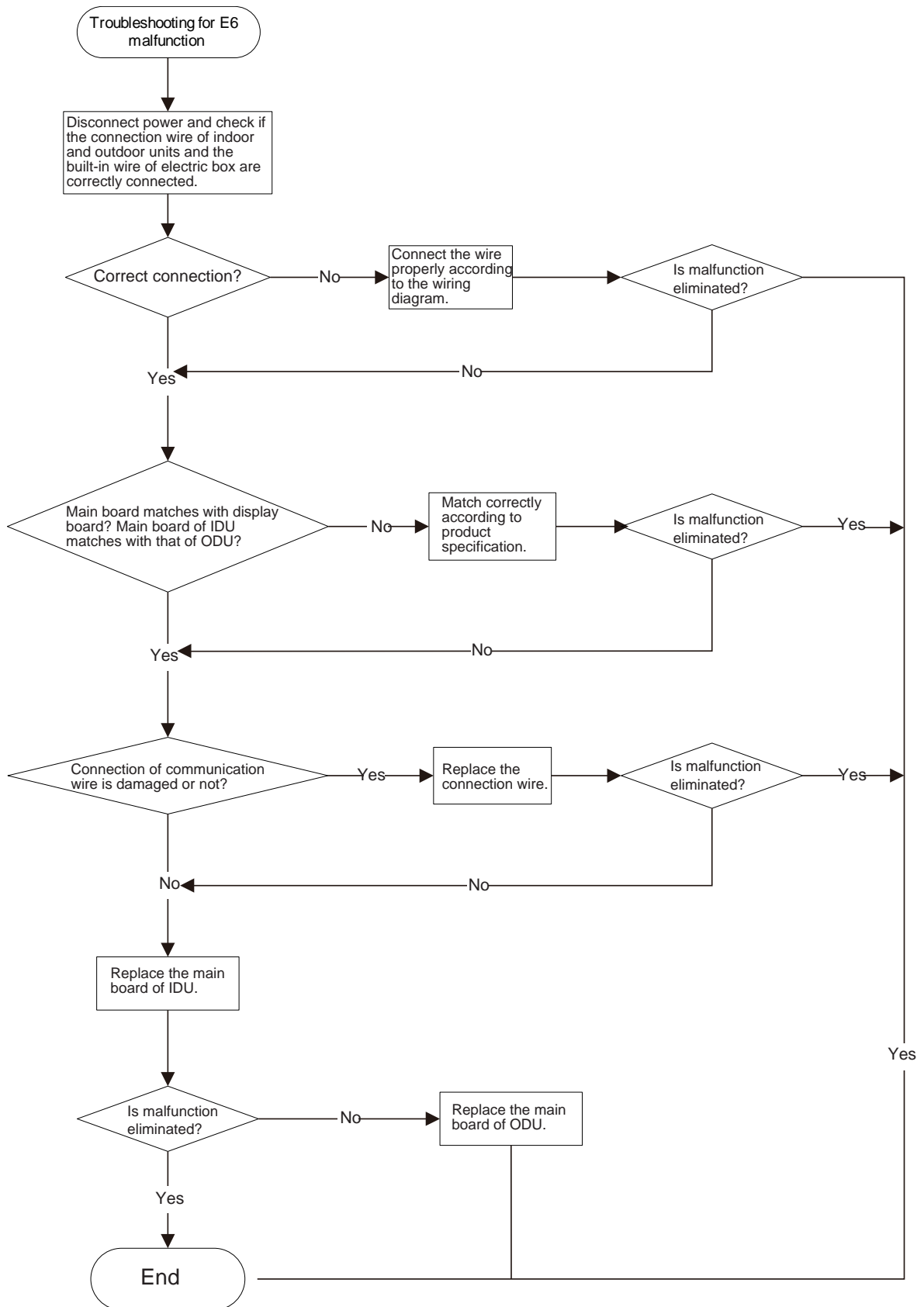

(6). Malfunction of detecting plate(WIFI) JF

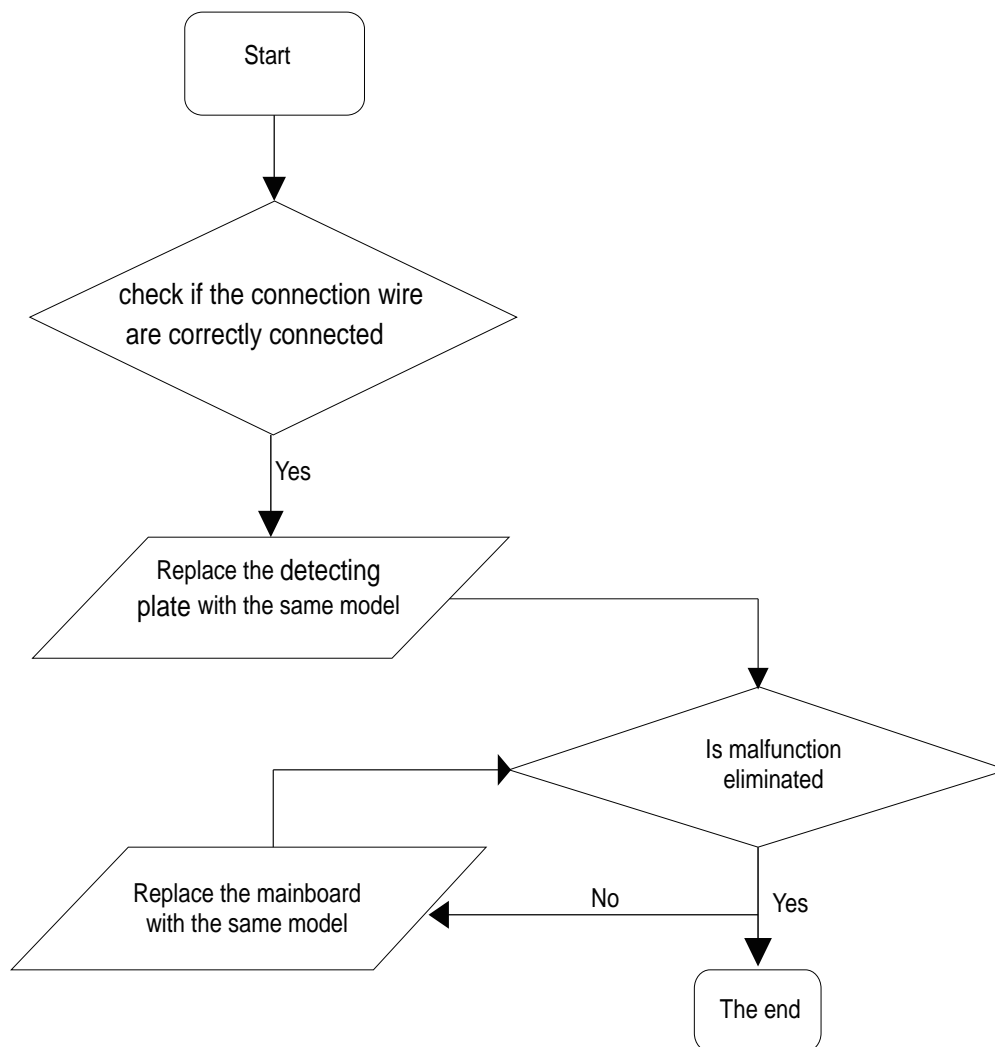

Outdoor Unit

(1) Malfunction of Desynchronizing of Compressor (H7)

Main check point:

Whether the system pressure is too high?

Whether the electronic expansion valve can work normally?

Whether the radiation for the unit is in good condition?

Malfunction diagnosis process:

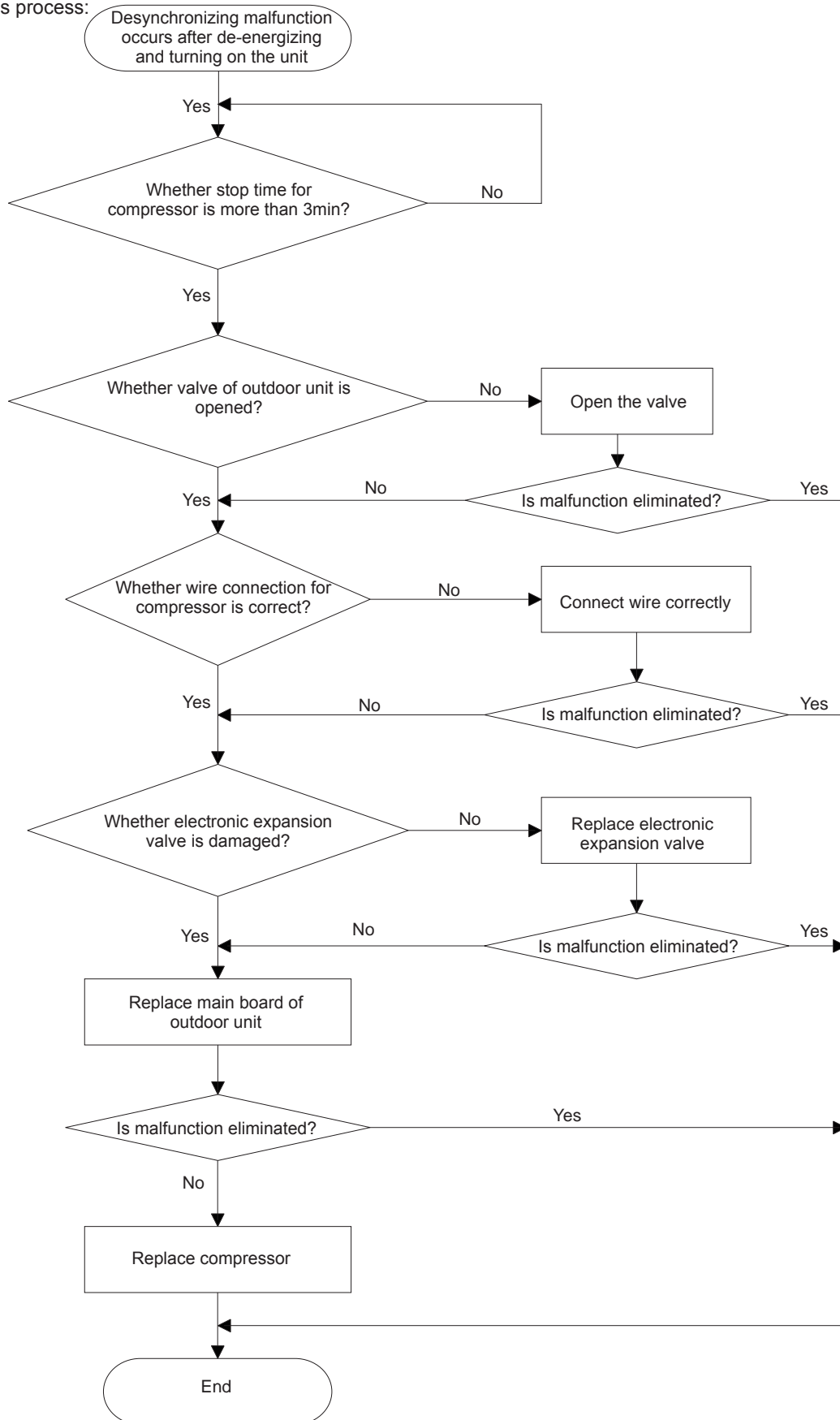

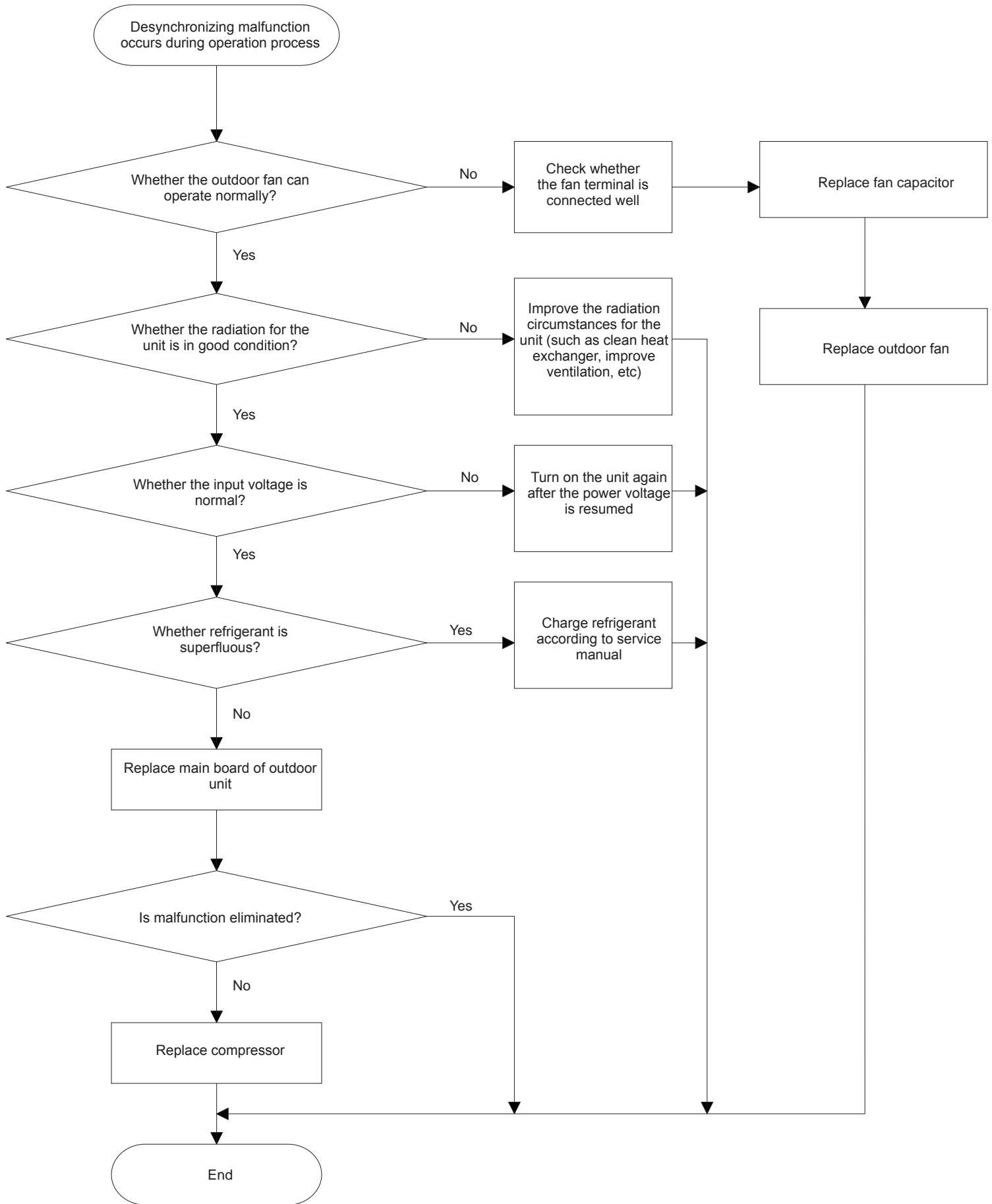

(2) Malfunction of Temperature Sensor (F3/F4/F5)

Main check point:

Whether the temperature sensor is damaged?

Whether the terminal of temperature sensor is loose or not connected?

Whether the main board is damaged?

Malfunction diagnosis process:

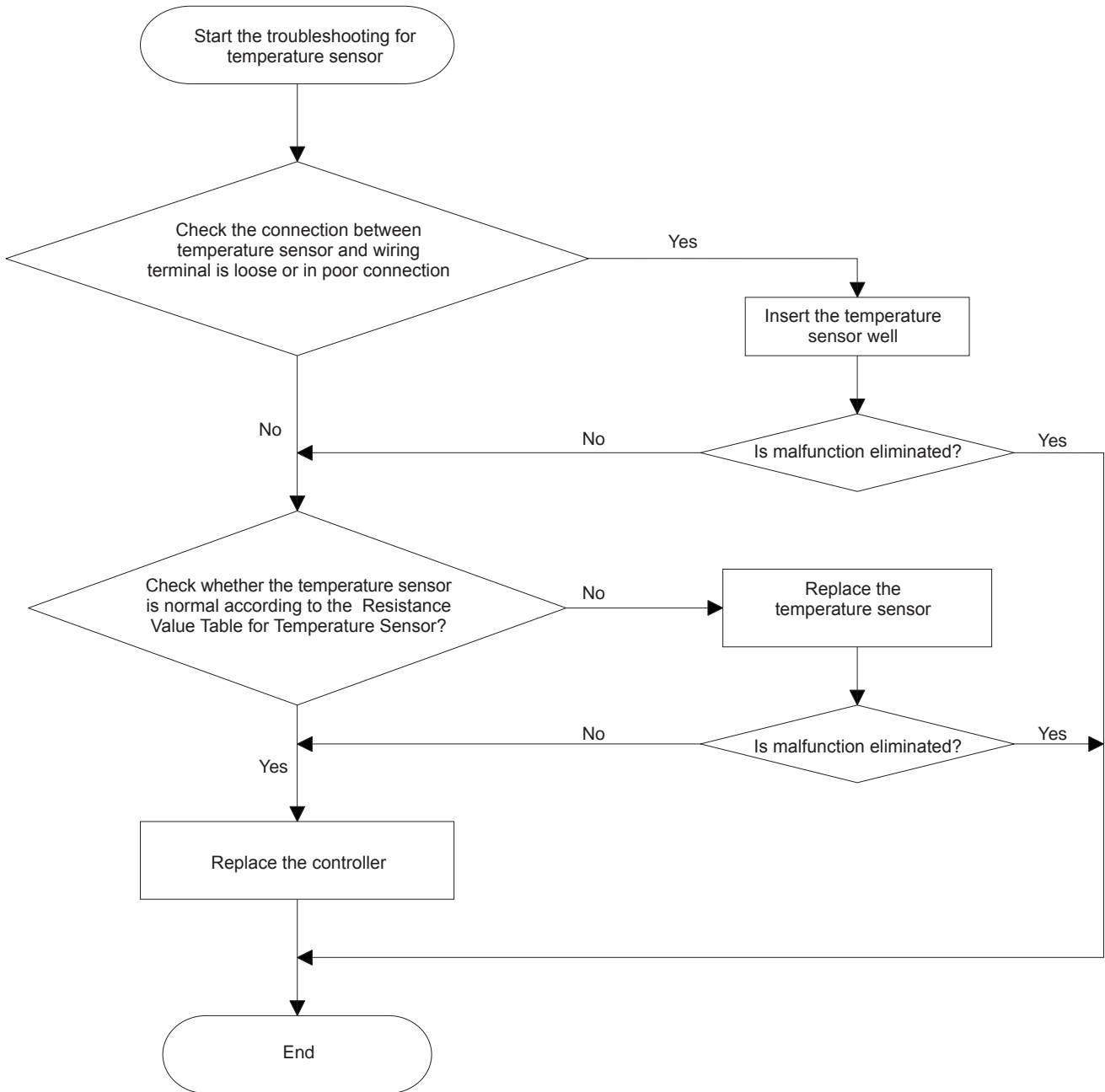

(3) Malfunction of Overload Protection of Compressor (H3) and Discharge High-temperature Protection of Compressor (E4)

Main check point:

Whether the electronic expansion valve is connected well and whether its damaged?

Whether the refrigerant is leaking?

Whether the overload protector is damaged?

Malfunction diagnosis process:

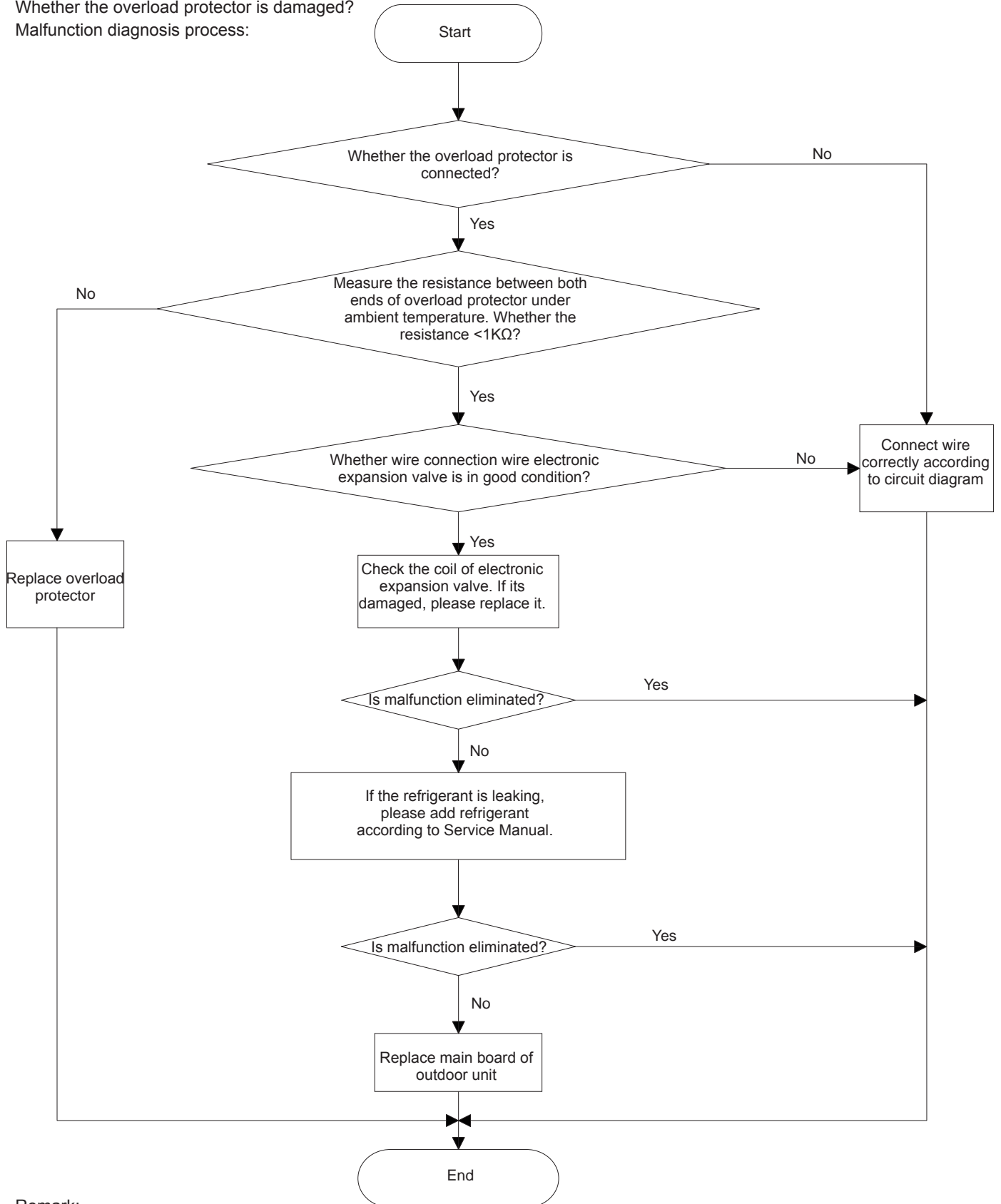

Remark:

Detection method for electronic expansion valve: There are 5 wires for the coil of electronic expansion valve and one of them are common port (the left or the right wire) .The resistance for other terminals are all most the same (about 100Ω). You can measure those resistance values to judge whether the electronic expansion valve is damaged or not.

(4) Charging Malfunction of Capacitor (PU)

Main check point:

Whether input power is normal?

Main board is damaged.

Malfunction diagnosis process:

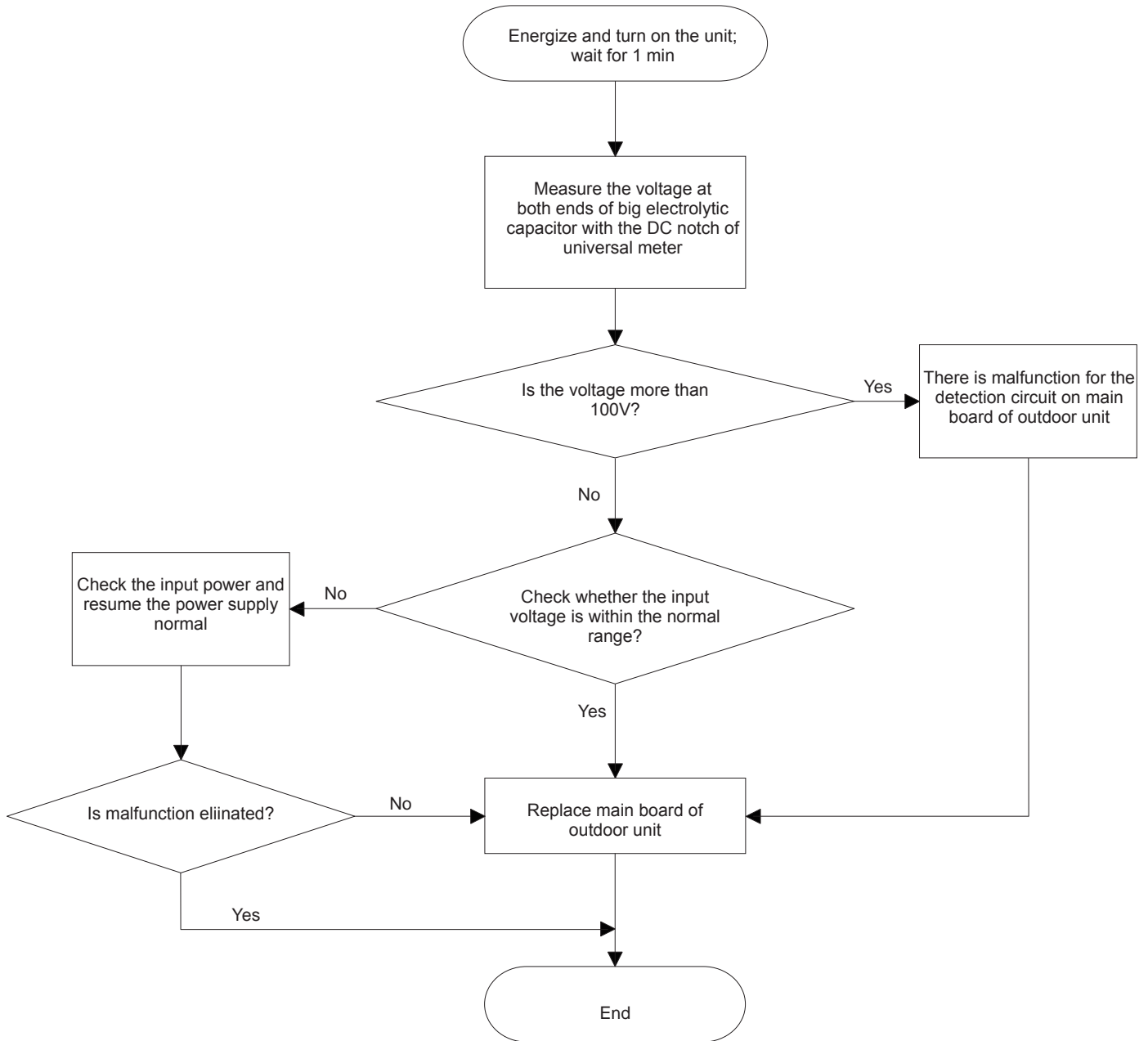

(5) Malfunction of Overload Protection (E8)

Main check point:

Whether the tube temperature sensor is normal?

Whether the outdoor ambient temperature is within the normal range?

Whether indoor fan and outdoor fan can operate normally?

Whether radiation environment inside or outside the unit is good?

Malfunction diagnosis process:

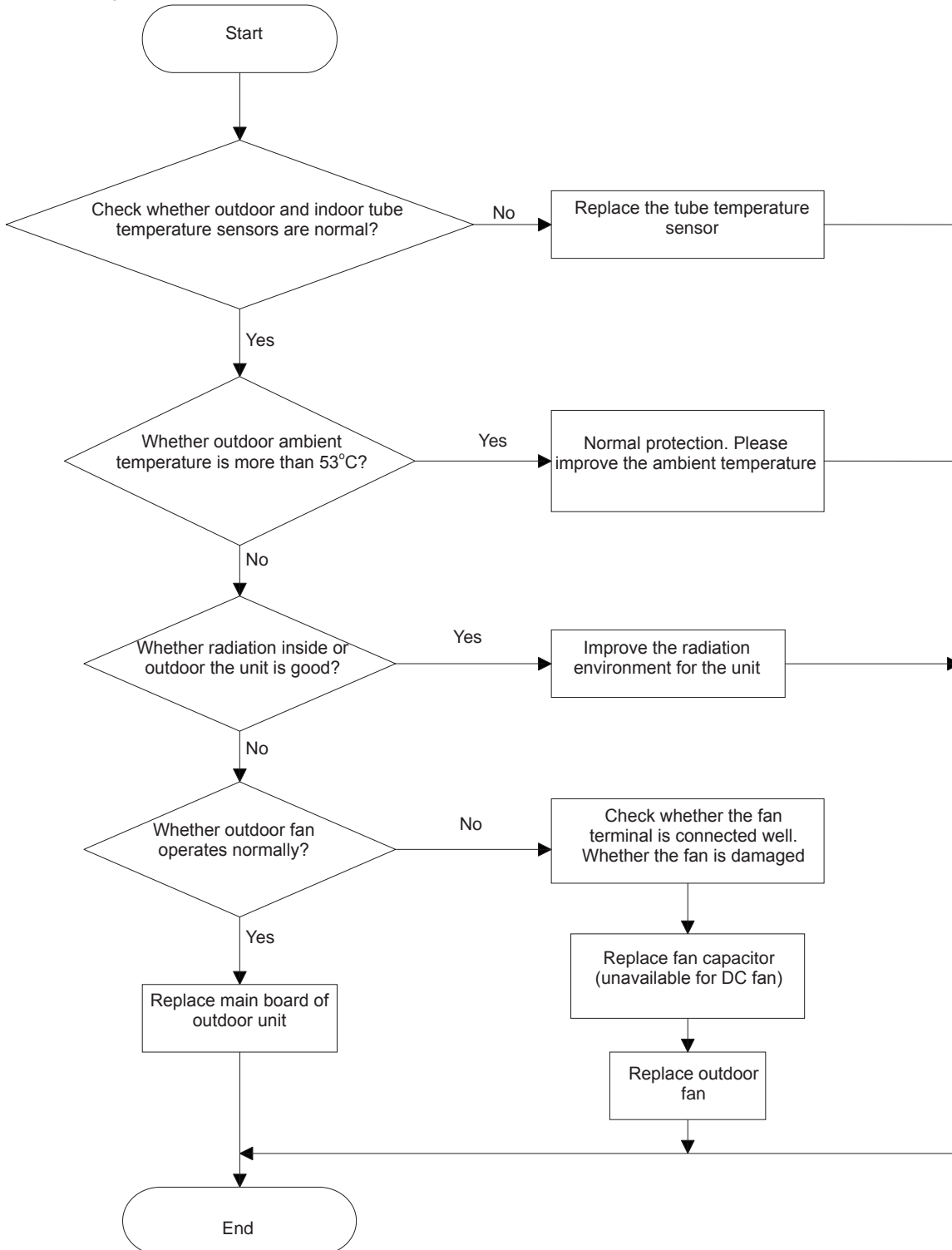

Remark:

When overload protection occurs under cooling mode, its because the main board detected the outdoor tube temperature sensor exceeds limited temperature and then the unit stops operation. Please check outdoor tube temperature sensor;

When overload protection occurs under heating mode, its because the main board detected the indoor tube temperature sensor exceeds limited temperature and then the unit stops operation. Please check indoor tube temperature sensor;

(6) Malfunction of IPM Protection (H5)

Main check point:

Whether input voltage is within the normal range?

Whether wires of compressor are connected reliably, tightly or correctly?

Whether the resistance of compressor coil is normal? Whether the insulation between compressor coil and copper pipe is in good condition?

Whether the unit is overloading? Whether the radiation for the unit is in good condition?

Whether the volume of charged refrigerant is proper?

Malfunction diagnosis process:

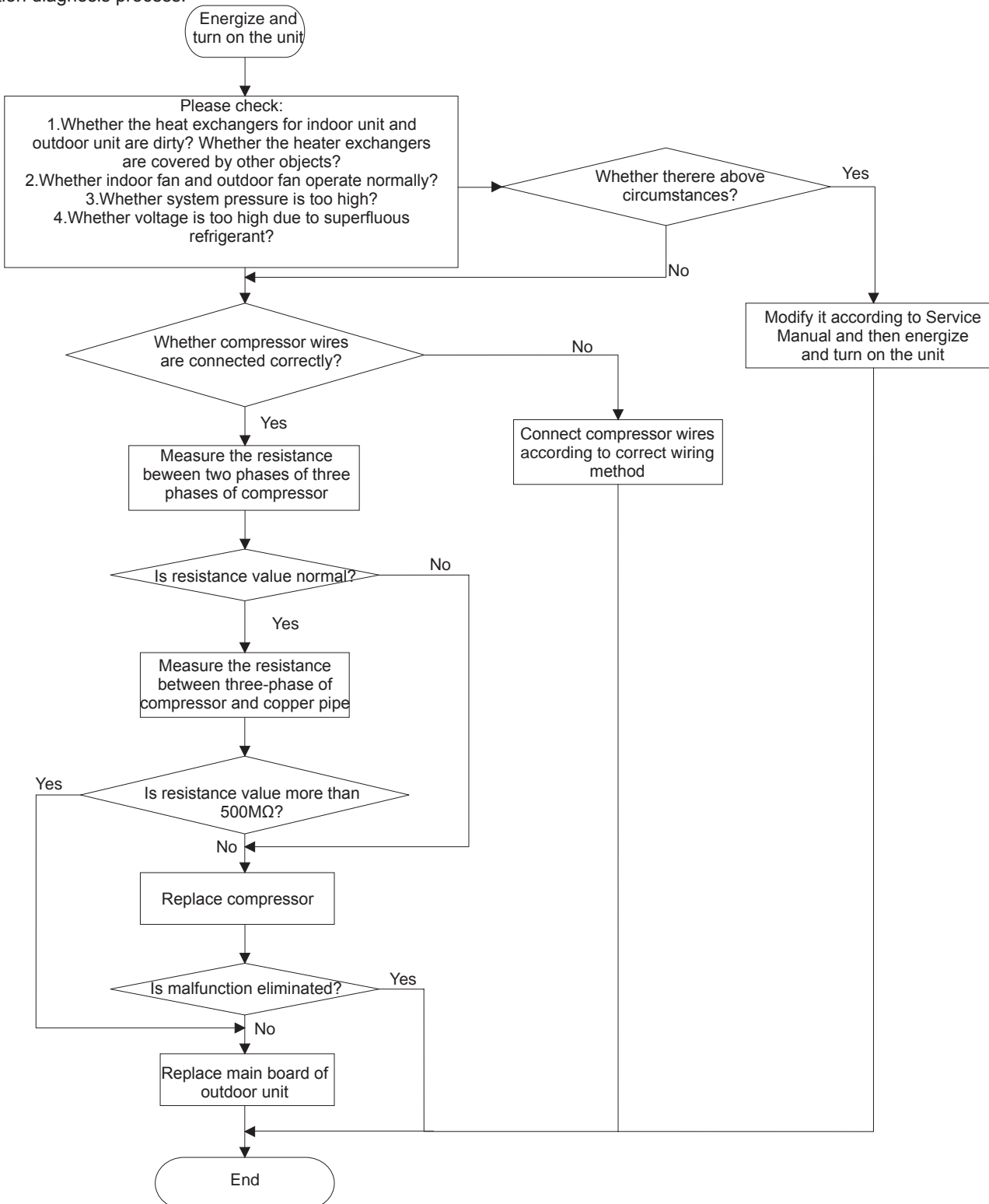

(8) Malfunction of Communication (E6)

Main check point:

Check whether connection wires between indoor unit and outdoor unit and wiring inside the unit are connected well?

Check the main board of indoor unit or main board of outdoor unit is damaged?

Malfunction diagnosis process:

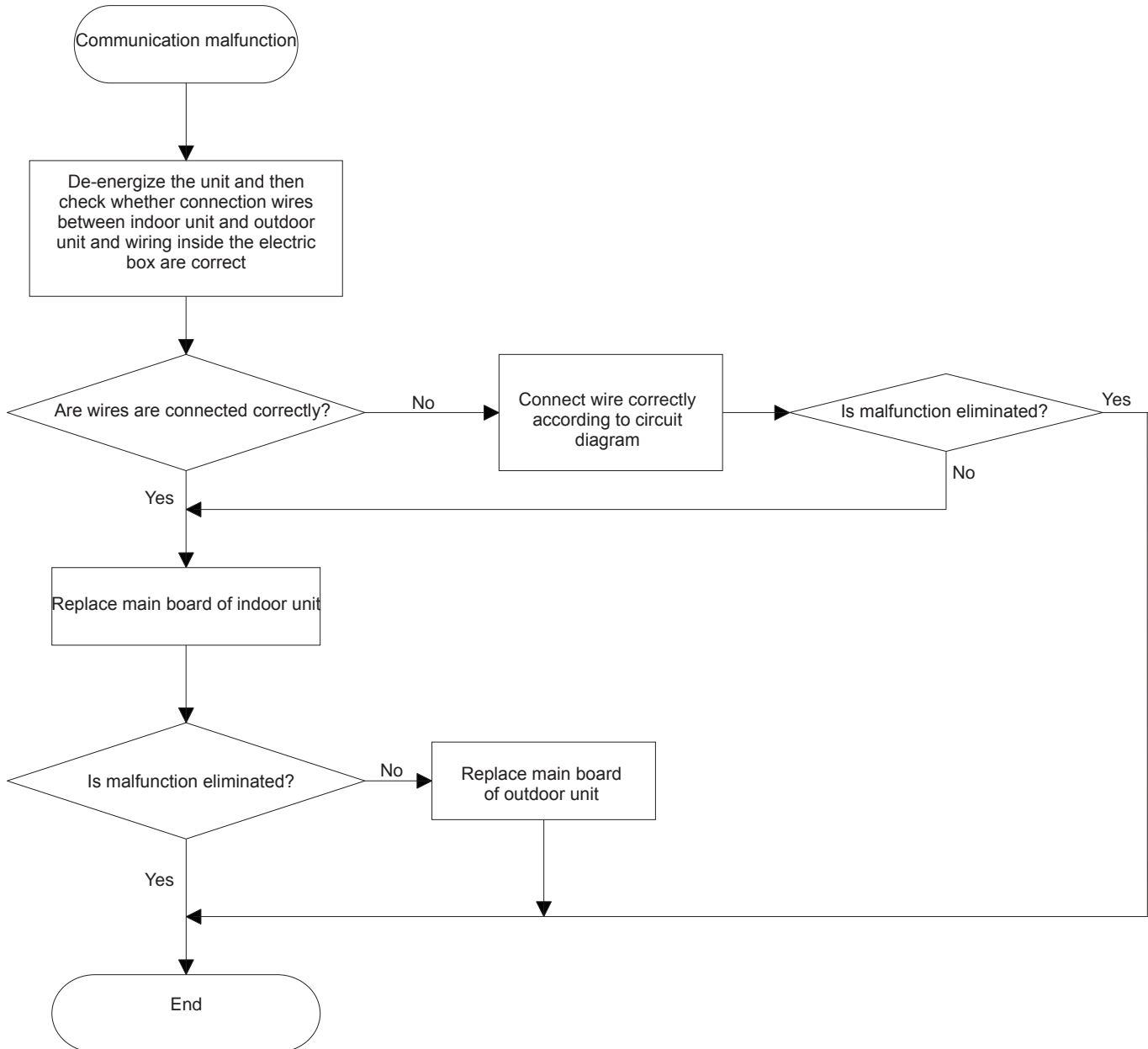

(9) Malfunction of Failure Start-up of Compressor (LC)

Main check point:

Whether the compressor wires are connected correctly?

Whether the stop time for compressor is enough?

Whether compressor is damaged?

Whether the refrigerant-charging volume is superfluous?

Malfunction diagnosis process:

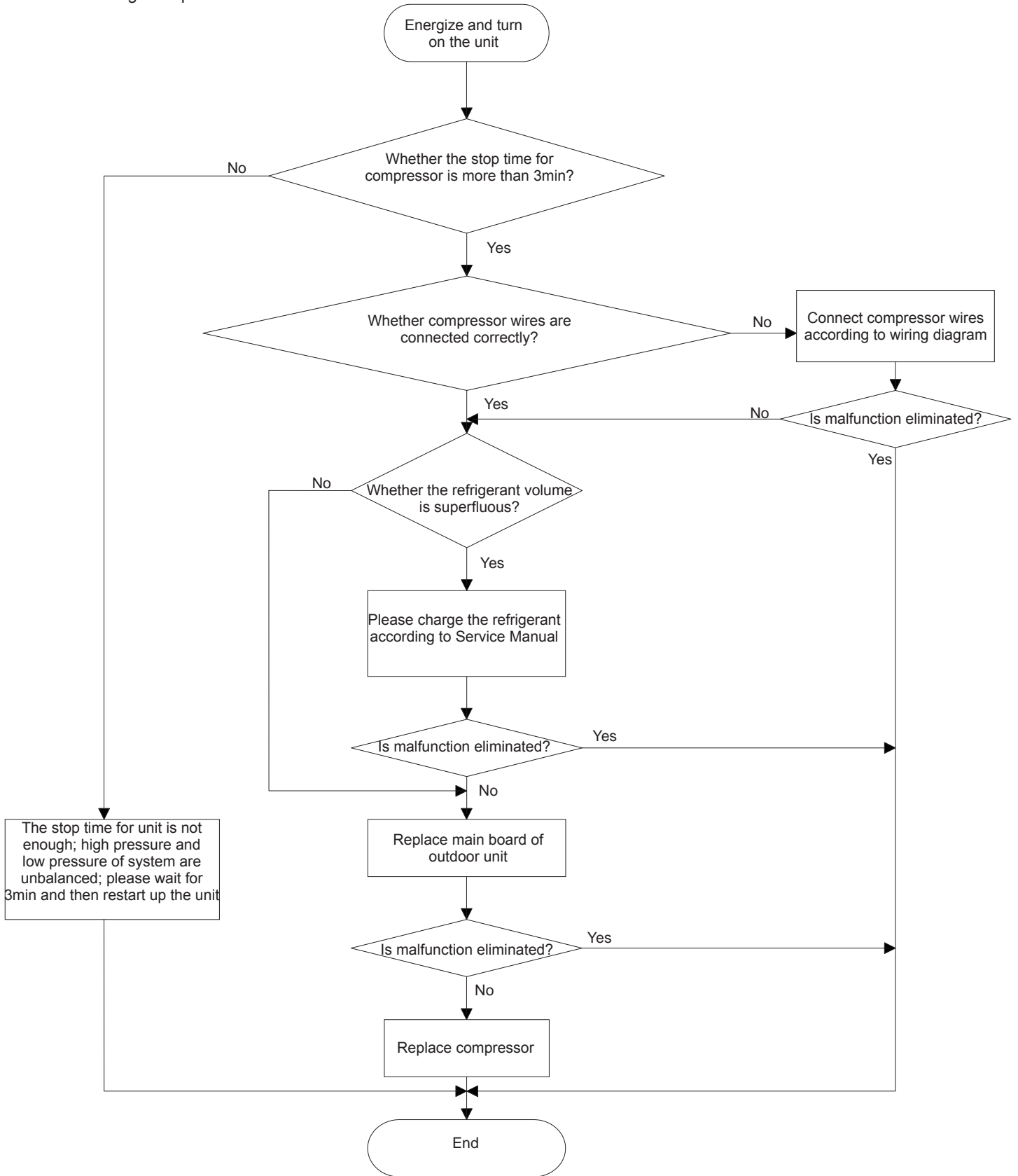

(10) Malfunction of Overcurrent Protection E5

Main detection points:

- Is the supply voltage unstable with big fluctuation?
- Is the supply voltage too low with overload?
- Hardware trouble?

Malfunction diagnosis process:

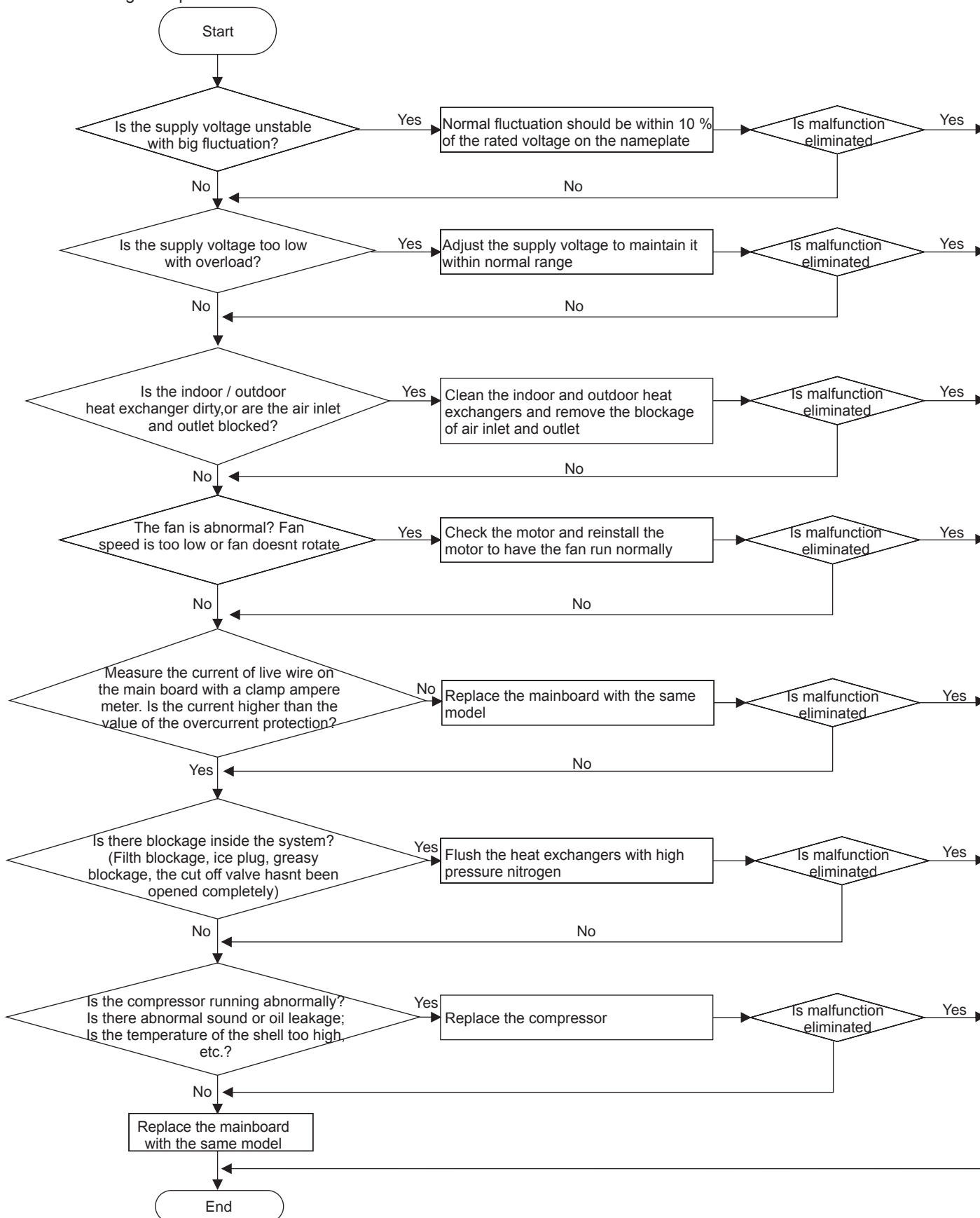

(11) Other Malfunction

1.IP module temperature sensor is open-circuited (P7)

Hardware of main board is damaged. Please replace main board.

2.Overheating protection of IPM module (P8)

- ① Poor radiation because the module radiator is dirty;
- ② IPM module is damaged;
- ③ Malfunction of outdoor fan, etc;

3.Detection circuit malfunctions of phase-current of compressor (U1)

Hardware of main board is damaged. Please replace main board.

4.DC busbar voltage is too high (PH)

- ① Input voltage is too high or unstable;
- ② Hardware of main board is damaged;

5.DC busbar voltage is too low (PL)

- ① Input voltage is too low or unstable;
- ② Hardware of main board is damaged;

6.Malfunction of ODU DC fan (L3)

- ① The wire terminal of outdoor fan motor is loosed, fix the terminal.
- ② Motor damaged, replace the motor.
- ③ Fan motor module on mainboard is damaged, replace the main board AP1

9.3 Maintenance method for normal malfunction

1. Air Conditioner Cant be Started Up

Possible Causes	Discriminating Method (Air conditioner Status)	Troubleshooting
No power supply, or poor connection for power plug	After energization, operation indicator isnt bright and the buzzer cant give out sound	Confirm whether its due to power failure. If yes, wait for power recovery. If not, check power supply circuit and make sure the power plug is connected well.
Wrong wire connection between indoor unit and outdoor unit, or poor connection for wiring terminals	Under normal power supply circumstances, operation indicator isnt bright after energization	Check the circuit according to circuit diagram and connect wires correctly. Make sure all wiring terminals are connected firmly
Electric leakage for air conditioner	After energization, room circuit breaker trips off at once	Make sure the air conditioner is grounded reliably Make sure wires of air conditioner is connected correctly Check the wiring inside air conditioner. Check whether the insulation layer of power cord is damaged; if yes, place the power cord.
Model selection for air switch is improper	After energization, air switch trips off	Select proper air switch
Malfunction of remote controller	After energization, operation indicator is bright, while no display on remote controller or buttons have no action.	Replace batteries for remote controller Repair or replace remote controller

2. Poor Cooling (Heating) for Air Conditioner

Possible Causes	Discriminating Method (Air conditioner Status)	Troubleshooting
Set temperature is improper	Observe the set temperature on remote controller	Adjust the set temperature
Rotation speed of the IDU fan motor is set too low	Small wind blow	Set the fan speed at high or medium
Filter of indoor unit is blocked	Check the filter to see its blocked	Clean the filter
Installation position for indoor unit and outdoor unit is improper	Check whether the installation position is proper according to installation requirement for air conditioner	Adjust the installation position, and install the rainproof and sunproof for outdoor unit
Refrigerant is leaking	Discharged air temperature during cooling is higher than normal discharged wind temperature; Discharged air temperature during heating is lower than normal discharged wind temperature; Units pressure is much lower than regulated range	Find out the leakage causes and deal with it. Add refrigerant.
Malfunction of 4-way valve	Blow cold wind during heating	Replace the 4-way valve
Malfunction of capillary	Discharged air temperature during cooling is higher than normal discharged wind temperature; Discharged air temperature during heating is lower than normal discharged wind temperature; Unit pressure is much lower than regulated range. If refrigerant isnt leaking, part of capillary is blocked	Replace the capillary
Flow volume of valve is insufficient	The pressure of valves is much lower than that stated in the specification	Open the valve completely
Malfunction of horizontal louver	Horizontal louver cant swing	Refer to point 3 of maintenance method for details
Malfunction of the IDU fan motor	The IDU fan motor cant operate	Refer to troubleshooting for H6 for maintenance method in details
Malfunction of the ODU fan motor	The ODU fan motor cant operate	Refer to point 4 of maintenance method for details
Malfunction of compressor	Compressor cant operate	Refer to point 5 of maintenance method for details

3. Horizontal Louver Cant Swing

Possible Causes	Discriminating Method (Air conditioner Status)	Troubleshooting
Wrong wire connection, or poor connection	Check the wiring status according to circuit diagram	Connect wires according to wiring diagram to make sure all wiring terminals are connected firmly
Stepping motor is damaged	Stepping motor cant operate	Repair or replace stepping motor
Main board is damaged	Others are all normal, while horizontal louver cant operate	Replace the main board with the same model

4. ODU Fan Motor Cant Operate

Possible causes	Discriminating method (air conditioner status)	Troubleshooting
Wrong wire connection, or poor connection	Check the wiring status according to circuit diagram	Connect wires according to wiring diagram to make sure all wiring terminals are connected firmly
Capacity of the ODU fan motor is damaged	Measure the capacity of fan capacitor with an universal meter and find that the capacity is out of the deviation range indicated on the nameplate of fan capacitor.	Replace the capacity of fan
Power voltage is a little low or high	Use universal meter to measure the power supply voltage. The voltage is a little high or low	Suggest to equip with voltage regulator
Motor of outdoor unit is damaged	When unit is on, cooling/heating performance is bad and ODU compressor generates a lot of noise and heat.	Change compressor oil and refrigerant. If no better, replace the compressor with a new one

5. Compressor Cant Operate

Possible causes	Discriminating method (air conditioner status)	Troubleshooting
Wrong wire connection, or poor connection	Check the wiring status according to circuit diagram	Connect wires according to wiring diagram to make sure all wiring terminals are connected firmly
Capacity of compressor is damaged	Measure the capacity of fan capacitor with an universal meter and find that the capacity is out of the deviation range indicated on the nameplate of fan capacitor.	Replace the compressor capacitor
Power voltage is a little low or high	Use universal meter to measure the power supply voltage. The voltage is a little high or low	Suggest to equip with voltage regulator
Coil of compressor is burnt out	Use universal meter to measure the resistance between compressor terminals and its 0	Repair or replace compressor
Cylinder of compressor is blocked	Compressor cant operate	Repair or replace compressor

6. Air Conditioner is Leaking

Possible causes	Discriminating method (air conditioner status)	Troubleshooting
Drain pipe is blocked	Water leaking from indoor unit	Eliminate the foreign objects inside the drain pipe
Drain pipe is broken	Water leaking from drain pipe	Replace drain pipe
Wrapping is not tight	Water leaking from the pipe connection place of indoor unit	Wrap it again and bundle it tightly

7. Abnormal Sound and Vibration

Possible causes	Discriminating method (air conditioner status)	Troubleshooting
When turn on or turn off the unit, the panel and other parts will expand and theres abnormal sound	Theres the sound of "PAPA"	Normal phenomenon. Abnormal sound will disappear after a few minutes.
When turn on or turn off the unit, theres abnormal sound due to flow of refrigerant inside air conditioner	Water-running sound can be heard	Normal phenomenon. Abnormal sound will disappear after a few minutes.
Foreign objects inside the indoor unit or therere parts touching together inside the indoor unit	Theres abnormal sound fro indoor unit	Remove foreign objects. Adjust all parts position of indoor unit, tighten screws and stick damping plaster between connected parts
Foreign objects inside the outdoor unit or therere parts touching together inside the outdoor unit	Theres abnormal sound fro outdoor unit	Remove foreign objects. Adjust all parts position of outdoor unit, tighten screws and stick damping plaster between connected parts
Short circuit inside the magnetic coil	During heating, the way valve has abnormal electromagnetic sound	Replace magnetic coil
Abnormal shake of compressor	Outdoor unit gives out abnormal sound	Adjust the support foot mat of compressor, tighten the bolts
Abnormal sound inside the compressor	Abnormal sound inside the compressor	If add too much refrigerant during maintenance, please reduce refrigerant properly. Replace compressor for other circumstances.

10. Exploded View and Parts List

10.1 Indoor Unit

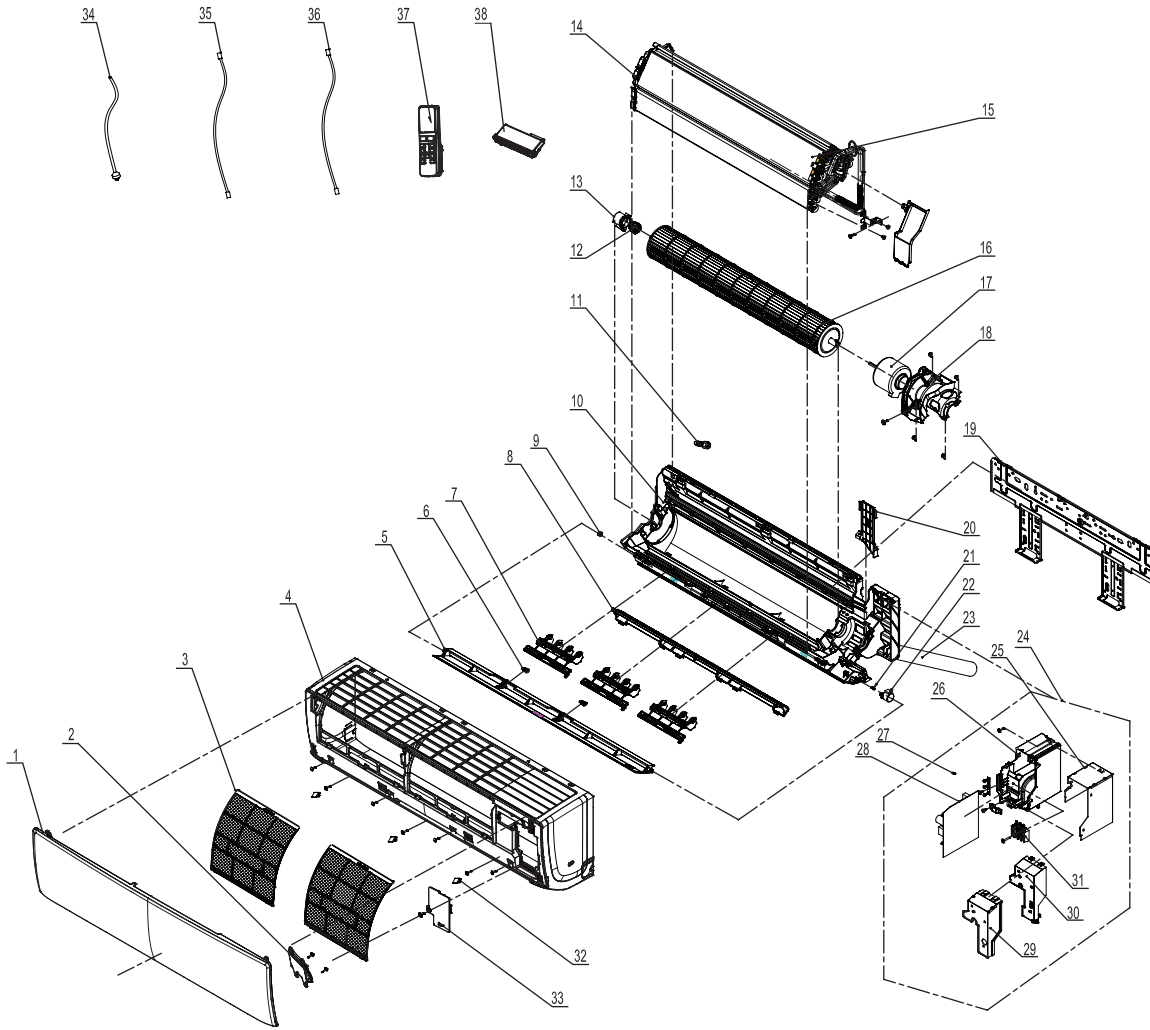

The component picture is only for reference; please refer to the actual product.

NO.	Description	Part Code			Qty
		GWH15AAD-K6DNA1A/I	GWH18AAD-K6DNA1A/I	GWH24AAD-K6DNA1A/I	
	Product Code	CB476N00600	CB476N00200	CB476N00100	
1	Front Panel	20000300003101T	20000300003101T	20000300003101T	1
2	Display Board	300001000037	300001000037	300001000037	1
3	Filter Sub-Assy	11122089	11122089	11122089	1
4	Front Case	20000200000801	20000200000801	20000200000801	1
5	Guide Louver	20000400000401	20000400000401	20000400000401	1
6	Axile Bush	10542036	10542036	10542036	2
7	Air Louver	10512732	10512732	10512732	3
8	Helicoid Tongue	26112512	26112512	26112512	1
9	Left Axile Bush	10512037	10512037	10512037	1
10	Rear Case assy	000001000009	000001000009	000001000009	1
11	Rubber Plug (Water Tray)	76712012	76712012	76712012	1
12	O-Gasket of Cross Fan Bearing	76512203	76512203	76512203	1
13	Ring of Bearing	26152025	26152025	26152025	1
14	Evaporator Support	24212177	24212177	24212177	1
15	Evaporator Assy	01100100020401	011001000207	01002000003	1
16	Cross Flow Fan	10352060	10352060	10352060	1
17	Fan Motor	1501214502	1501214502	1501214502	1
18	Motor Press Plate	26112511	26112511	26112511	1
19	Wall Mounting Frame	01362026	01362026	01362026	1
20	Connecting pipe clamp	2611218801	2611218801	2611218801	1
21	Crank	73012005	73012005	73012005	1
22	Stepping Motor	1521240210	1521240210	1521240210	1
23	Drainage Hose	05230014	05230014	05230014	1
24	Electric Box Assy	100002001422	100002001422	100002001355	1
25	Lower Shield of Electric Box	01592139	01592139	01592139	1
26	Electric Box	20112211	20112211	20112211	1
27	Jumper	4202021912	4202021912	4202021912	1
28	Main Board	300002000397	300002000397	300002000397	1
29	Shield Cover of Electric Box	01592176	01592176	01592176	1
30	Electric Box Cover	20112209	20112209	20112209	1
31	Terminal Board	42011233	42011233	42011233	1
32	Screw Cover	242520179	242520179	242520179	3
33	Electric Box Cover2	20112210	20112210	20112210	1
34	Power Cord	/	/	/	/
35	Connecting Cable	/	/	/	/
36	Connecting Cable	4002052317	4002052317	4002052317	0
37	Remote Controller	305001000009	305001000009	305001000009	1
38	Detecting plate(WIFI)	30110144	30110144	30110144	1

Above data is subject to change without notice.

NO.	Description	Part Code	Qty
		GWH24AAD-K6DNA5A/I	
		Product Code	
		CB488N00500	
1	Front Panel	200003000114T01	1
2	Display Board	300001000042	1
3	Filter Sub-Assy	11122089	1
4	Front Case	20000200000801	1
5	Guide Louver	20000400000401	1
6	Axile Bush	10542036	2
7	Air Louver	10512732	3
8	Helicoid Tongue	26112512	1
9	Left Axile Bush	10512037	1
10	Rear Case assy	000001000009	1
11	Rubber Plug (Water Tray)	76712012	1
12	O-Gasket of Cross Fan Bearing	76512203	1
13	Ring of Bearing	26152025	1
14	Evaporator Support	24212177	1
15	Evaporator Assy	01002000003	1
16	Cross Flow Fan	10352060	1
17	Fan Motor	1501214502	1
18	Motor Press Plate	26112511	1
19	Wall Mounting Frame	01362026	1
20	Connecting pipe clamp	2611218801	1
21	Crank	73012005	1
22	Stepping Motor	1521240210	1
23	Drainage Hose	05230014	1
24	Electric Box Assy	100002001513	1
25	Lower Shield of Electric Box	01592139	1
26	Electric Box	20112211	1
27	Jumper	4202021912	1
28	Main Board	300002000397	1
29	Shield Cover of Electric Box	01592176	1
30	Electric Box Cover	20112209	1
31	Terminal Board	42011233	1
32	Screw Cover	242520179	3
33	Electric Box Cover2	20112210	1
34	Power Cord	/	/
35	Connecting Cable	/	/
36	Connecting Cable	4002052317	0
37	Remote Controller	305001000009	1
38	Detecting plate(WIFI)	30110144	1

Above data is subject to change without notice.

10.2 Outdoor Unit

18K

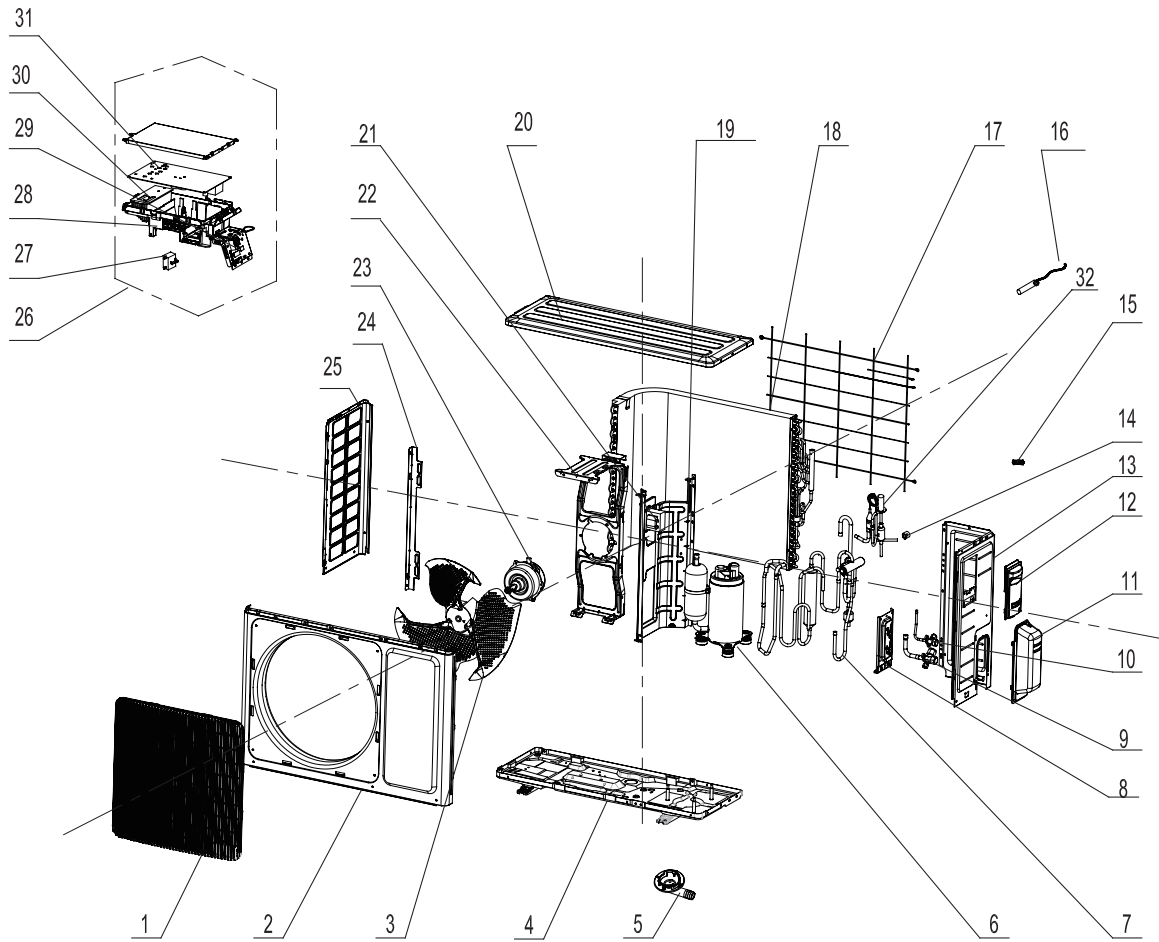

The component picture is only for reference; please refer to the actual product.

No.	Description	Part Code	Qty
		GWH18AAD-K6DNA1A/O	
		Product Code	
		CB476W00200	
1	Front Grill	22413046	1
2	Cabinet	01433034P	1
3	Axial Flow Fan	10333014	1
4	Chassis Sub-assy	01205176P	1
5	Drainage Joint	26113009	1
6	Compressor and Fittings	00103919G	1
7	4-Way Valve Assy	030152000146	1
8	Valve Support Sub-Assy	01713115P	1
9	Cut off Valve Sub-Assy	030057000072	1
10	Cut off Valve Sub-Assy	07133774	1
11	Valve Cover	22243005	1
12	Big Handle	2623343106	1
13	Right Side Plate	0130324403P	1
14	4 Way Valve Coil	4300040087	1
15	Wire Clamp	71010103	1
16	Temperature Sensor	3900030902	1
17	Rear Grill	01473060	1
18	Condenser Assy	011002000417	1
19	Clapboard Sub-Assy	01233168	1
20	Coping	01253034P	1
21	Reactor	/	/
22	Motor Support Sub-Assy	0170339802	1
23	Fan Motor	1501371701	1
24	Condenser Support Plate	01795028	1
25	Left Side Plate	01303169P	1
26	Electric Box Assy	100002001268	1
27	Capacitor CBB61	/	/
28	Electric Box	20113027	1
29	Terminal Board	420101943	1
30	Radiator	49013076	1
31	Main Board	300027000175	1
32	Electric Expansion Valve Sub-Assy	030026000166	1

Above data is subject to change without notice.

24K

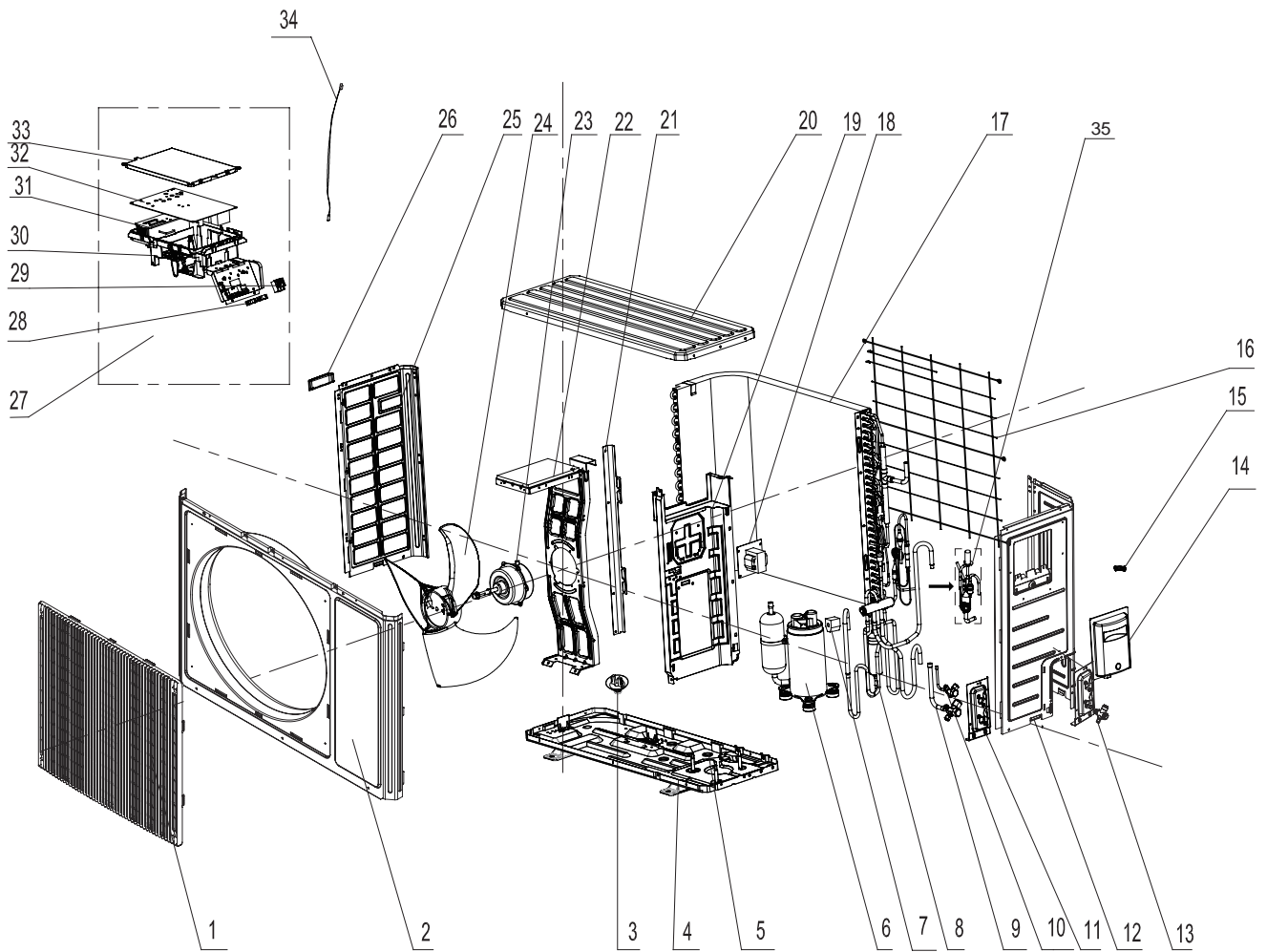

The component picture is only for reference; please refer to the actual product.

No.	Description	Part Code	Qty
		GWH24AAD-K6DNA1A/O	
		Product Code CB476W00100	
1	Front Grill	22415010	1
2	Front Panel	01535013P	1
3	Drainage Connector	06123401	1
4	Chassis Sub-assy	01700000161P01	1
5	Drainage Joint	06123401	1
6	Compressor and Fittings	00103919G	1
7	Magnet Coil	/	/
8	4-Way Valve Assy	030152000073	1
9	Cut off Valve Assy	07133844	1
10	Cut off Valve Sub-Assy	07133843	1
11	Valve support assy	26113017	1
12	Right Side Plate	0130509001P	1
13	Valve Support	01705047	1
14	Handle	2623305301	1
15	Wire Clamp	71010003	1
16	Rear Grill	01475020	1
17	Condenser Assy	011002000177	1
18	Reactor	/	/
19	Clapboard Sub-Assy	01235081	1
20	Coping	012049000007P	1
21	Supporting Board(Condenser)	01795031	1
22	Motor Support Sub-Assy	01705067	1
23	Fan Motor	1501506402	1
24	Axial Flow Fan	10335008	1
25	Left Side Plate	01305093P	1
26	Left handle	2623305301	1
27	Electric Box Assy	100002001276	1
28	Wire Clamp	71010003	1
29	Terminal Board	420101943	1
30	Electric Box	20113027	1
31	Radiator	49013076	1
32	Main Board	300027000263	1
33	Insulated Board (Cover of Electric Box)	20113003	1
34	Temperature Sensor	3900030902	1
35	Electronic Expansion Valve assy	03017400002801	1

Above data is subject to change without notice.

15K

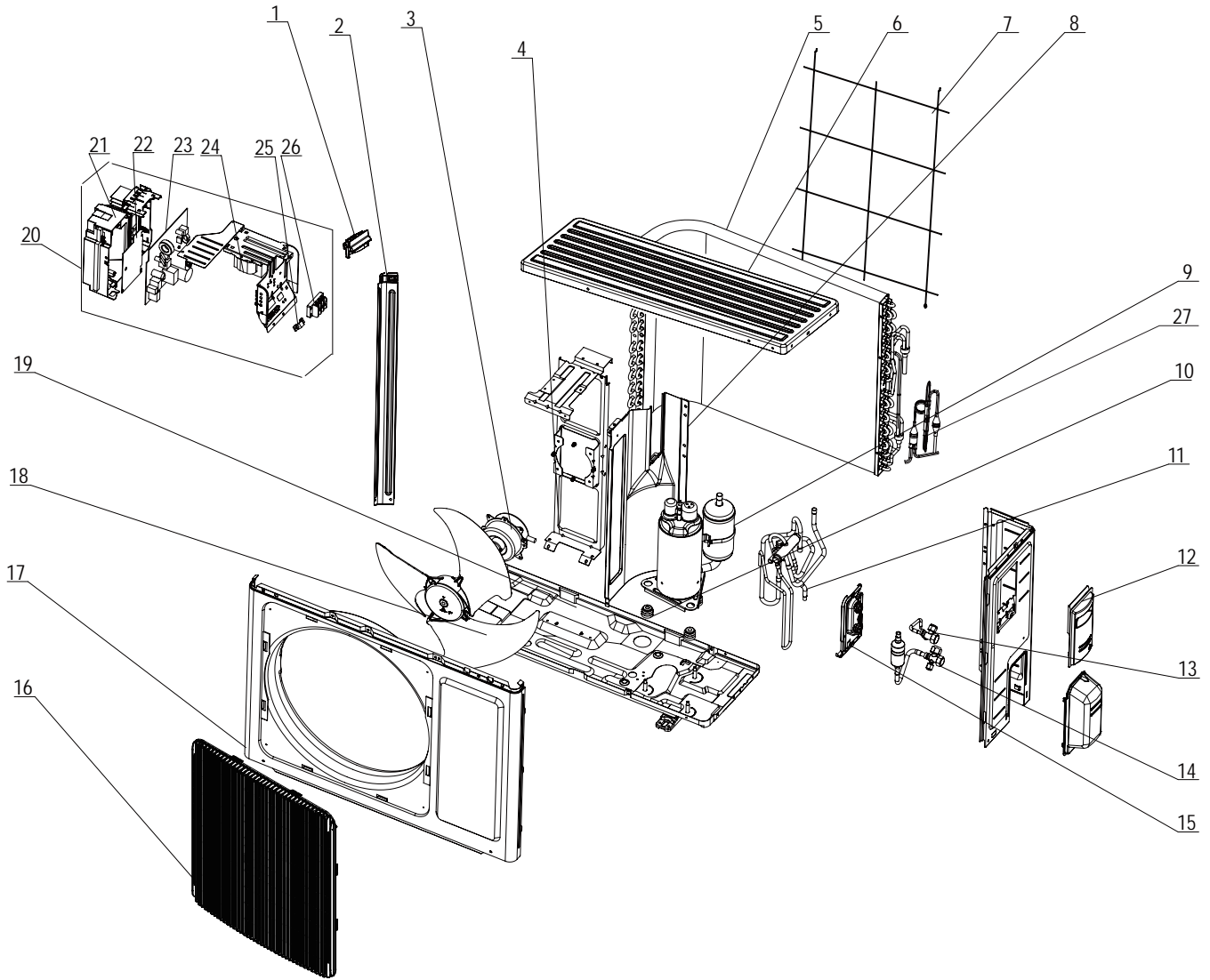

The component picture is only for reference; please refer to the actual product.

No.	Description	Part Code	
		GWH15AAD-K6DNA1A/O	
		CB476W00600	
		Qty	
1	Handle	/	/
2	Supporting Board	01173194	1
3	Fan Motor	011002000529	1
4	Motor Support	1501308507	1
5	Condenser Assy	01703136	1
6	Coping	01253081	1
7	Rear Grill	01475014	1
8	Clapboard Sub-Assy	01233180	1
9	Compressor and Fittings	00103925G	1
10	Compressor Gasket	76710287	3
11	4-Way Valve Assy	030152000158	1
12	Big Handle	2623343106	1
13	Cut off Valve Sub-Assy	03005700067	1
14	Cut off Valve Assy	07133691	1
15	Valve Support	26113017	2
16	Front Grill	22413044	1
17	Cabinet	01433033	1
18	Axial Flow Fan	10333011	1
19	Chassis Sub-assy	02803213	1
20	Electric Box Assy	017007000305	1
21	Electric Box	100002001857	1
22	Filter Board	/	/
23	Main Board	300027000337	1
24	Reactor	49013066	1
25	Wire Clamp	71010103	1
26	Terminal Board	42010313	1
27	Capillary Sub-assy	030006000472	1

Above data is subject to change without notice.

11. Removal Procedure

11.1 Removal Procedure of Indoor Unit

! Caution: discharge the refrigerant completely before removal.

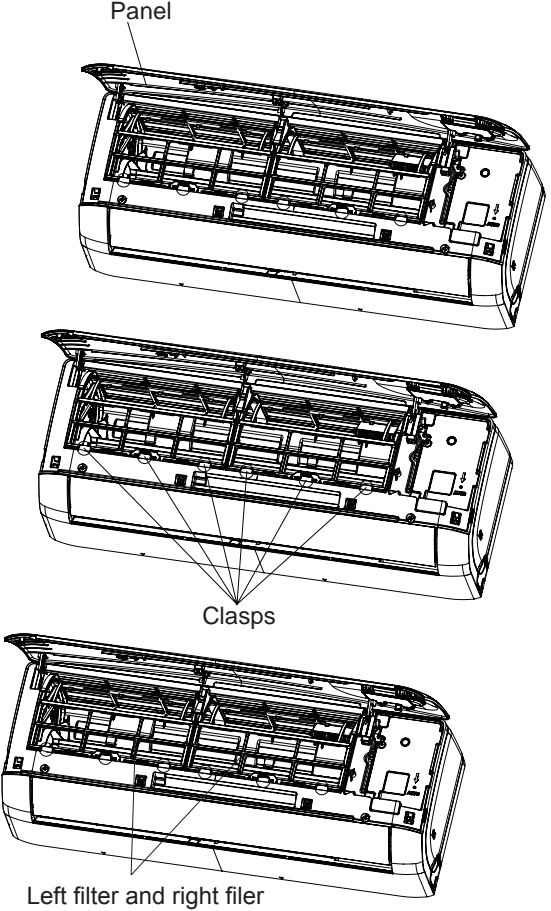
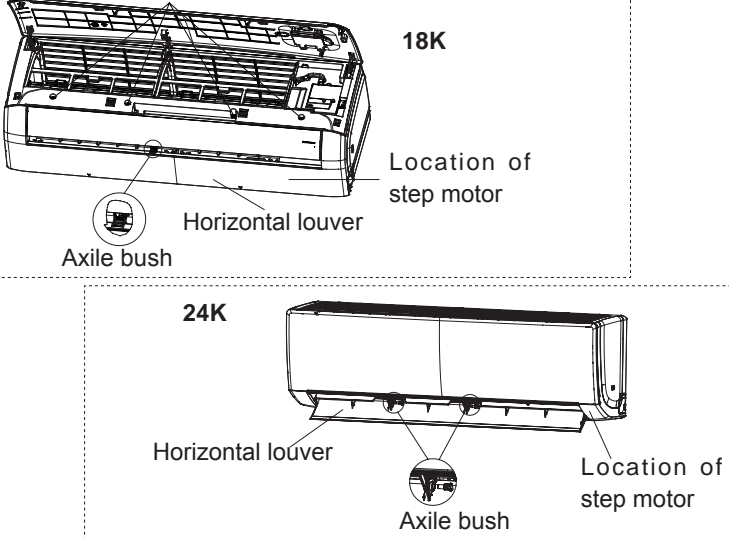
Step	Procedure	
1. Remove filter	<p>a Open the panel.</p> <p>b Loosen the clasp shown in the fig and then pull the left filter and right filter outwards to remove them.</p>	 <p>Panel</p> <p>Clasps</p> <p>Left filter and right filter</p>
2. Remove horizontal louver	<p>Push out the axle bush on horizontal louver. Bend the horizontal louver with hand and then separate the horizontal louver from the crankshaft of step motor to remove it.</p>	 <p>18K</p> <p>Location of step motor</p> <p>Horizontal louver</p> <p>Axile bush</p> <p>24K</p> <p>Horizontal louver</p> <p>Axile bush</p> <p>Location of step motor</p>

Step	Procedure	Image
3. Remove panel	<p>Open the front panel; separate the panel rotation shaft from the groove fixing the front panel and then removes the front panel.</p> <p>Note: The display of some models is fixed on the panel; unscrew the screws fixing the display on the panel before removing the panel.</p>	
4. Remove electric box cover 2 and detecting plate	<p>Remove the screws on the electric box cover 2 and detecting plate(WIFI), then remove the electric box cover 2 and detecting plate(WIFI).</p> <p>Note: The position of detection board(WIFI) may be different for different models.</p>	
5. Remove front case sub-assy	<p>a Remove the screws fixing front case.</p> <p>Note: (1) Open the screw caps before removing the screws around the air outlet. (2) The quantity of screws fixing the front case sub-assy is different for different models.</p> <p>b Loosen the clasps at left, middle and right sides of front case. Lift the front case sub-assy upwards to remove it.</p>	

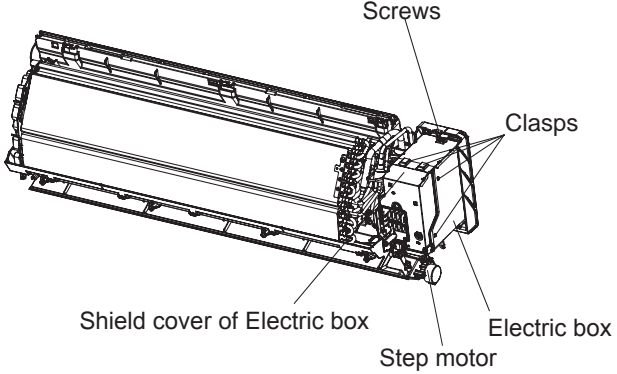
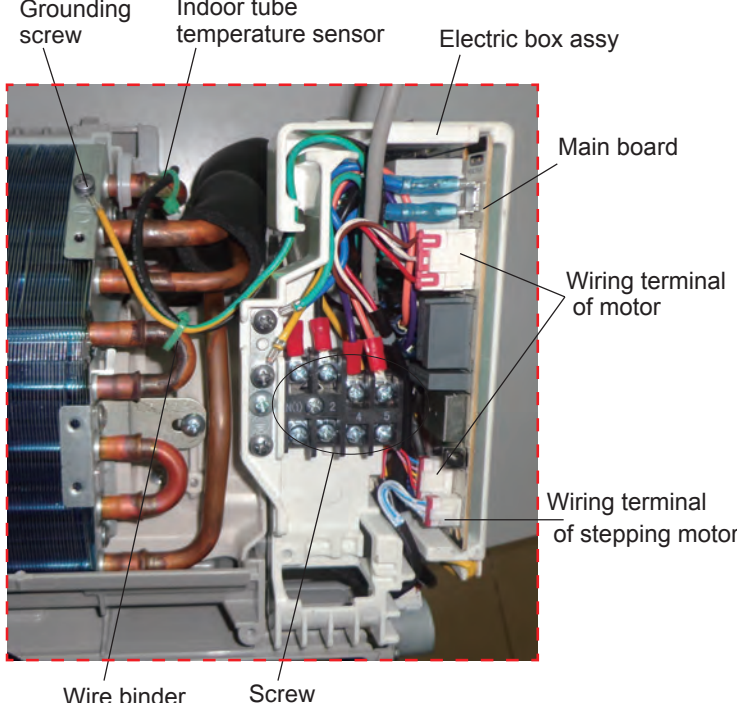
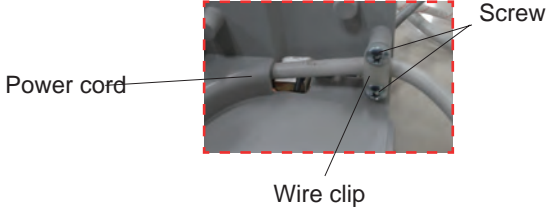
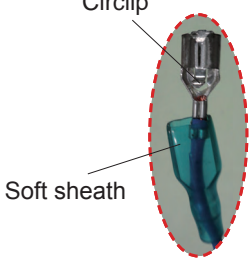
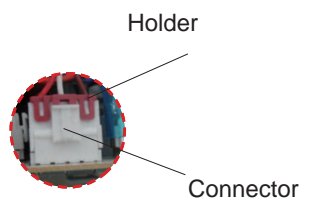
Step	Procedure
6. Remove electric box assy	
a	<p>Loosen the connection clasps between Cold plasma generator and electric box, and then remove the cold plasma generator.</p> 
b	<p>① Cut off the wire binder and pull out the indoor tube temperature sensor. ② Screw off one grounding screw. ③ Remove the wiring terminals of motor and stepping motor. ④ Remove the electric box assy. ⑤ Screw off the screws that are locking each.</p> 
c	<p>Rotate the electric box assy. Twist off the screws that are locking the wire clip and loosen the power cord. Remove the wiring terminal of power cord. Lift up the main board and take it off.</p>  <p>Instruction: Some wiring terminal of this product is with lock catch and other devices. The pulling method is as below: 1.Remove the soft sheath for some terminals at first, hold the circlip and then pull out the terminals. 2.Pull out the holder for some terminals at first (holder is not available for some wiring terminal), hold the connector and then pull the terminal.</p>  

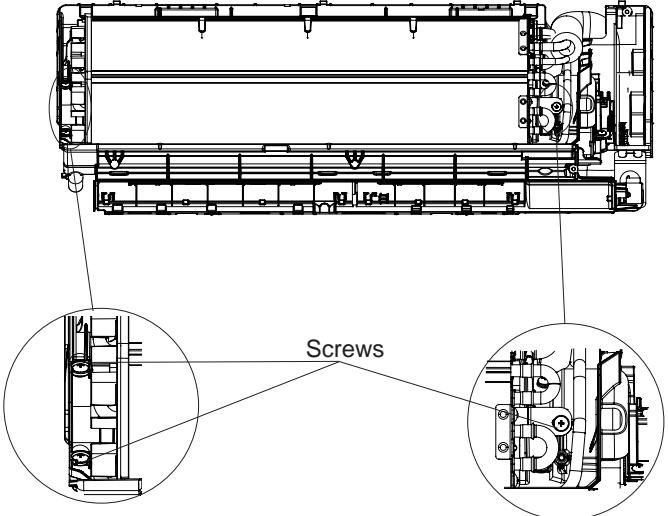
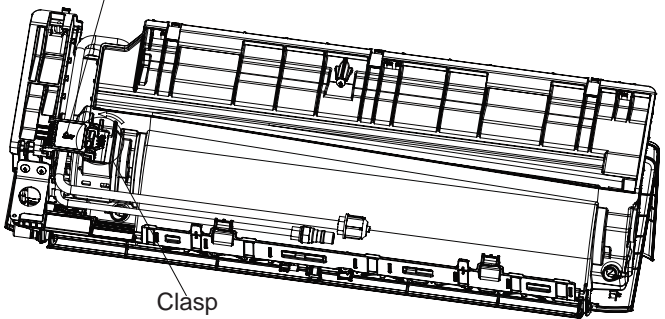
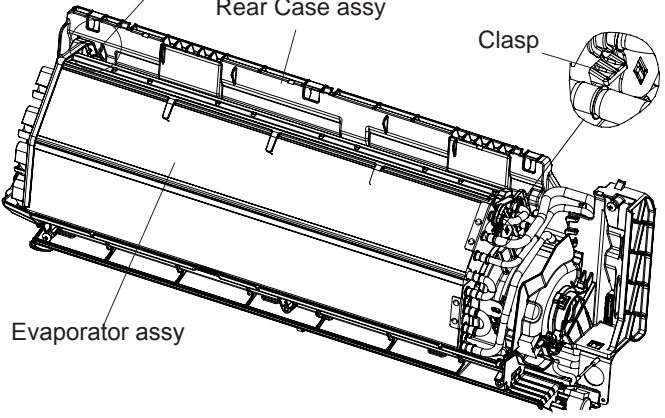
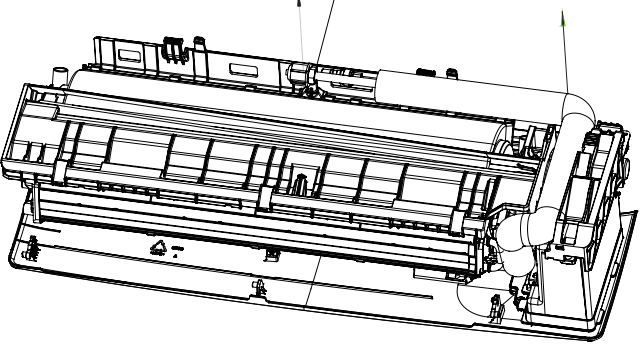
Step	Procedure	
7. Remove evaporator assy		
a	Remove 3 screws fixing evaporator assy.	 <p>Screws</p>
b	At the back of the unit, Loosen the clasp, connection pipe clamp and then remove the connection pipe clamp.	 <p>Connection pipe clamp</p> <p>Clasp</p>
c	First remove the left side of evaporator from the groove of bottom shell and then remove the right side from the clasp on the bottom shell.	 <p>Groove</p> <p>Rear Case assy</p> <p>Clasp</p> <p>Evaporator assy</p>
d	Adjust the position of connection pipe on evaporator slightly and then lift the evaporator upwards to remove it.	 <p>Connection pipe</p>

Step	Procedure	Diagram
8. Remove motor and cross flow blade	<p>a Remove 3 screws fixing motor clamp and then remove the motor clamp.</p> <p>b Remove the at the connection place of cross flow blade and motor; lift the motor and cross flow blade upwards to remove them.</p>	
9. Remove vertical louver	<p>Loosen the connection clasps between vertical louver and bottom case to remove vertical louver.</p>	

11.2 Removal Procedure of Outdoor Unit

18K

Warning: Be sure to wait for a minimum of 20 minutes after turning off all power supplies and discharge the refrigerant completely before removal.

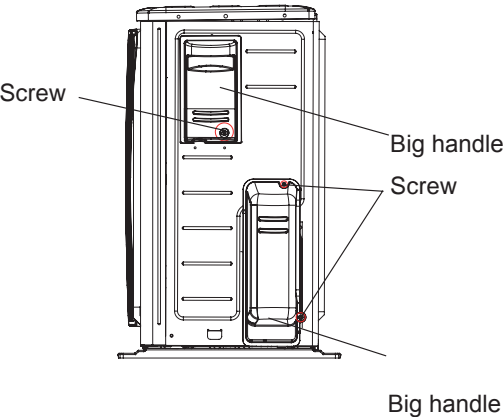
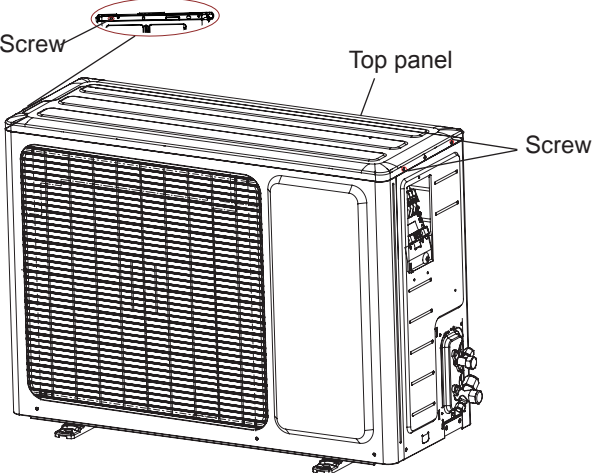
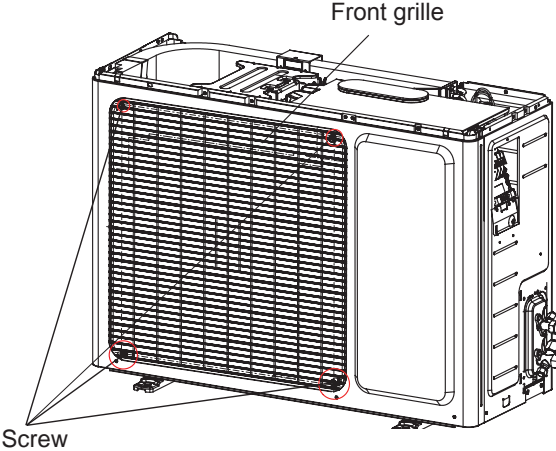
Step	Procedure
<p>1. Remove big handle</p>	<p>Remove the screw fixing big handle; slide out the big handle down wards to make the clasp of big handle separate from the groove of right side plate, and then remove the big handle.</p> 
<p>2. Remove top panel</p>	<p>Remove the screws fixing top panel and then remove the top panel.</p> 
<p>3. Remove front grille</p>	<p>Remove connection screws between the front grille and the front panel. Then remove the front grille.</p> 

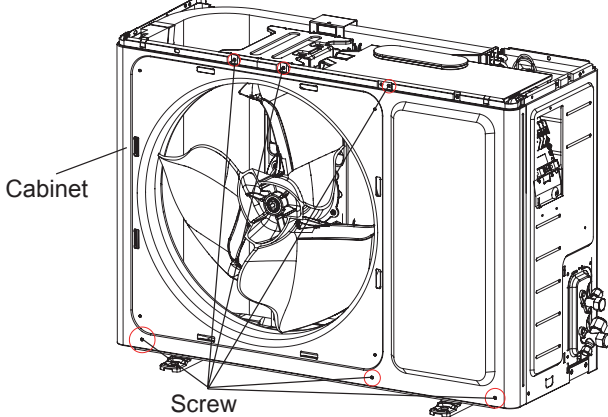
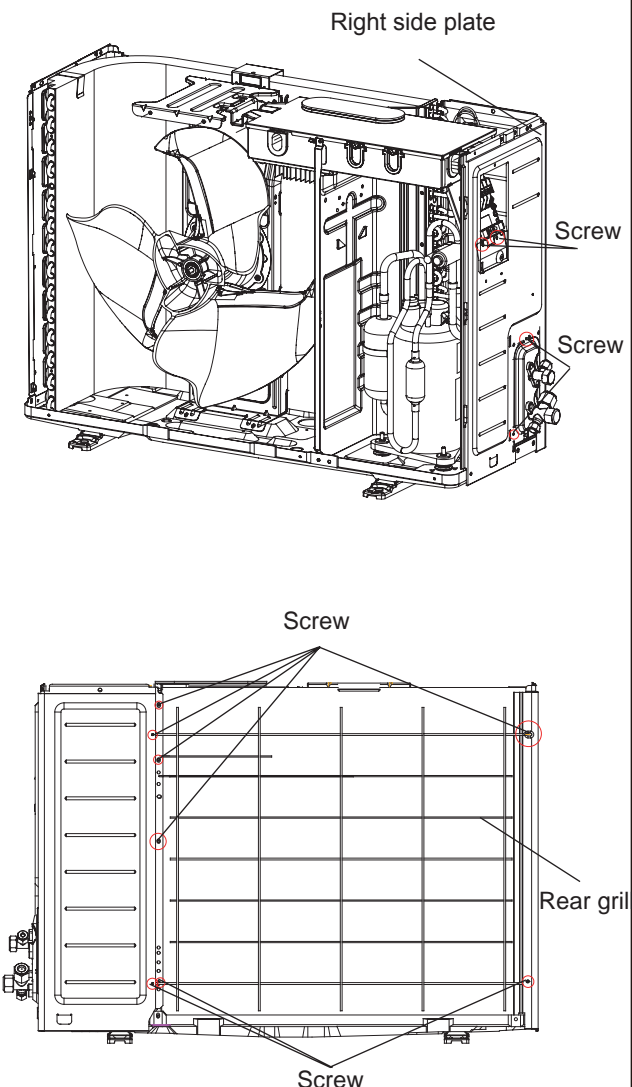
Step	Procedure
4.Remove cabinet	<p data-bbox="235 301 701 366">Remove the screws fixing cabinet and then remove the cabinet.</p> 
5.Remove right side plate and rear grill	<p data-bbox="235 840 678 906">Remove the screws fixing right side plate and then remove the right side plate.</p> <p data-bbox="235 1365 678 1430">Remove the screws and then remove the grille.</p> 

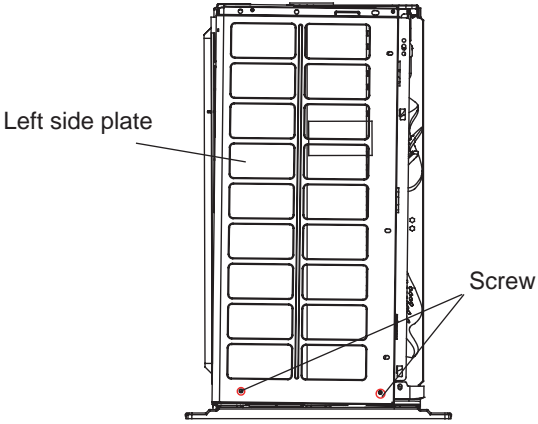
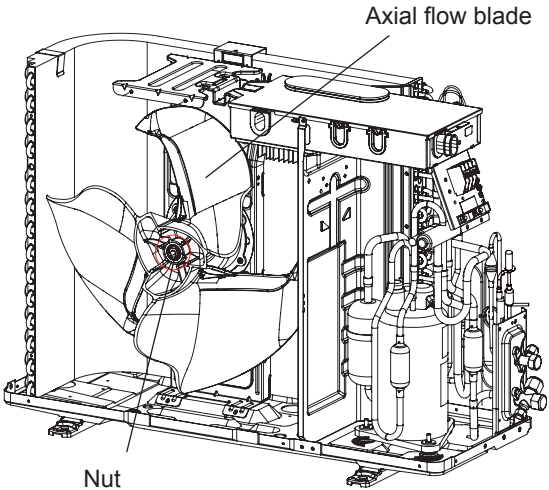
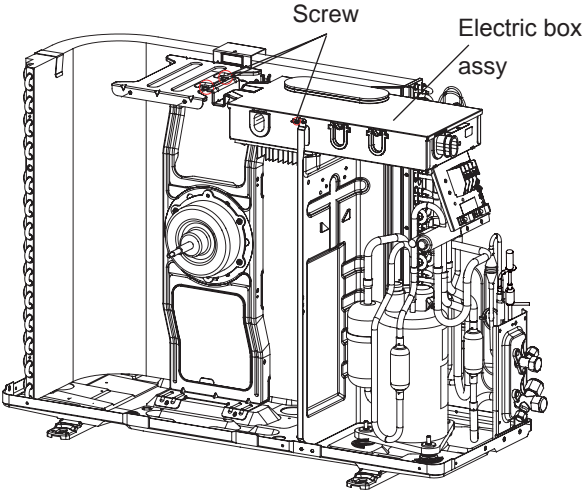
Step	Procedure
<p>6.Remove lef side plate</p>	<p>Remove the screws fixing left side plate and then remove the left side plate.</p>  <p>The diagram shows a vertical rectangular panel with a grid of eight rectangular compartments. A line points from the label 'Left side plate' to the left edge of the panel. Another line points from the label 'Screw' to one of the screws along the right edge of the panel.</p>
<p>7.Remove axial flow blade</p>	<p>Remove the nut fixing axial flow blade and then remove the axial flow blade.</p>  <p>The diagram shows a complex mechanical assembly. A large, curved blade is mounted on a central hub. A line points from the label 'Axial flow blade' to the blade. Another line points from the label 'Nut' to a nut on the central hub.</p>
<p>8.Remove electric box assy</p>	<p>Remove the screws fixing electric box assy ; pull out each wiring terminal; lift the electric box assy upwards to remove it.</p> <p>Note: When pulling out the wiring terminal, pay attention to loose the clasp and dont pull it so hard.</p>  <p>The diagram shows the same complex mechanical assembly as in step 7. A rectangular box is mounted on top of the assembly. A line points from the label 'Screw' to one of the screws on the top edge of the box. Another line points from the label 'Electric box assy' to the box itself.</p>

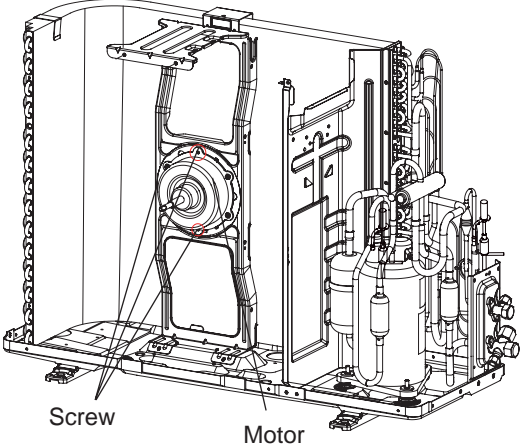
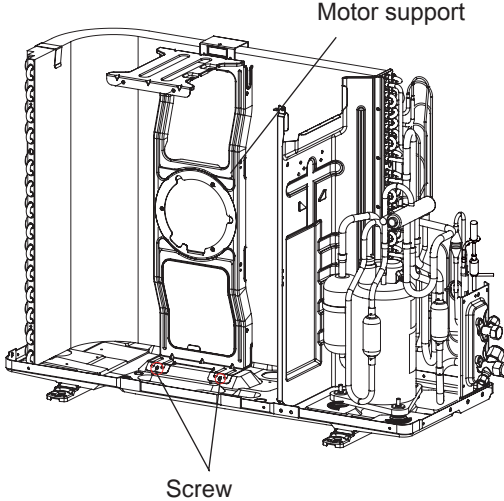
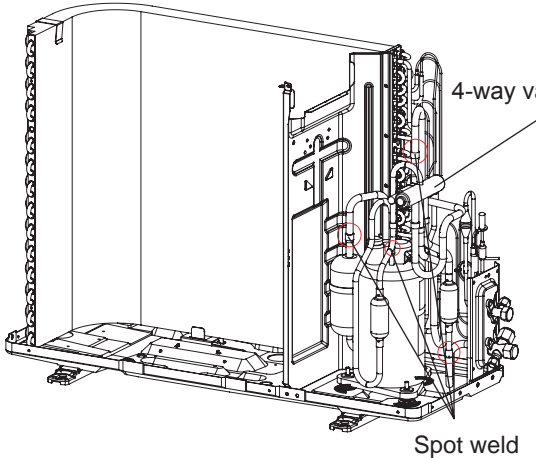
Step	Procedure
<p>9.Remove motor</p>	<p>Remove the screws fixing motor and then remove the motor.</p> 
<p>10.Remove motor support</p>	<p>Remove the screws fixing motor support and then remove the motor support.</p> 
<p>11.Remove 4-way valve assy</p>	<p>Unsolder the spot weld of 4-way valve assy, compressor and condenser, and then remove the 4-way valve assy . Note: When unsoldering the spot weld, wrap the 4-way valve with wet cloth completely to avoid damaging the valve due to high temperature.</p> 

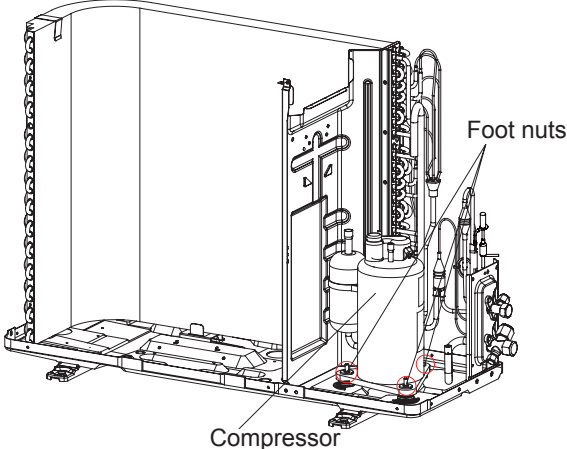
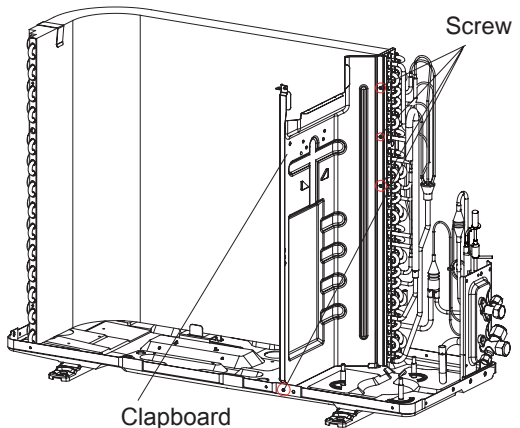
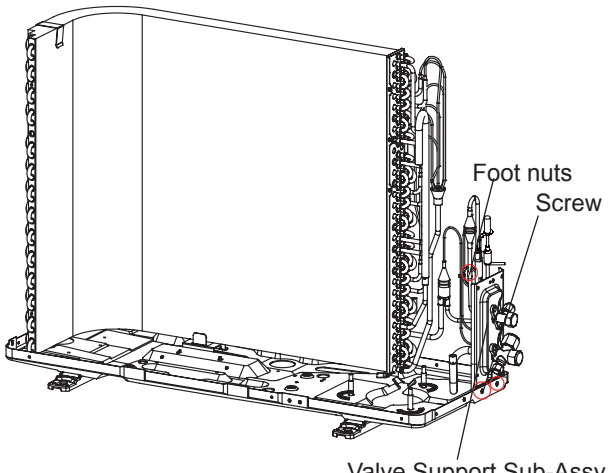
Step	Procedure	
12.Remove compressor	<p>Remove 3 foot nuts on compressor, and then remove the compressor.</p> <p>Note: Protect the ports of discharge pipe and suction pipe to avoid foreign objects to enter it.</p>	 <p>The diagram shows a side view of the compressor assembly. Three foot nuts are indicated by red circles and arrows, and the main compressor unit is labeled 'Compressor'.</p>
13.Remove clapboard	<p>Remove the screws fixing clapboard and then remove the clapboard.</p>	 <p>The diagram shows the clapboard assembly. A screw is indicated by a red circle and arrow, and the clapboard itself is labeled 'Clapboard'.</p>
14.Remove valve support sub-assy	<p>Screw off the screws that are locking the valve support sub-assy. Then remove it.</p>	 <p>The diagram shows the valve support sub-assembly. Two foot nuts and one screw are indicated by red circles and arrows. The sub-assembly is labeled 'Valve Support Sub-Assy'.</p>

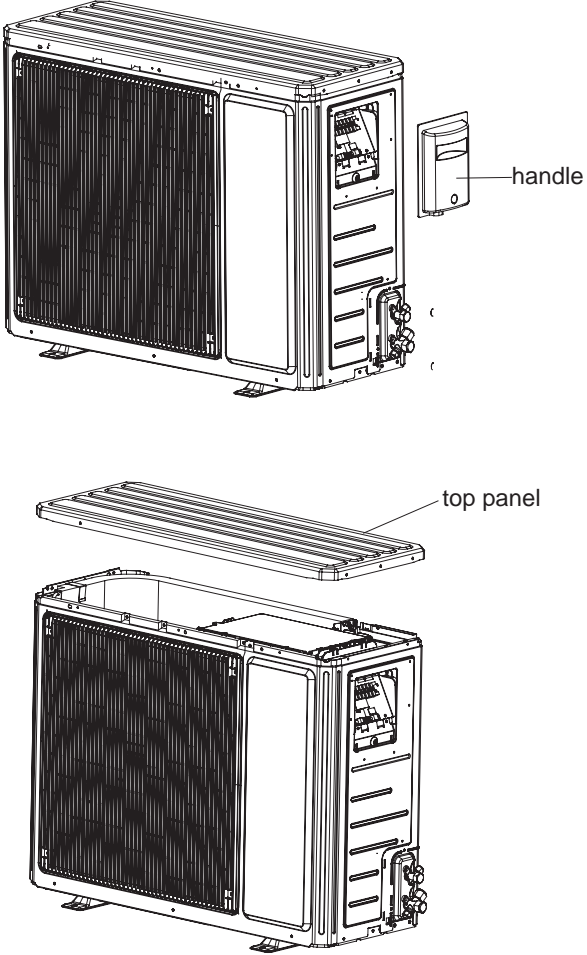
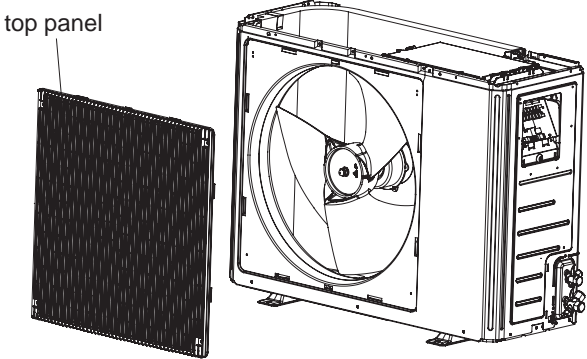
Steps	Procedure	Procedure
<p>1. Remove top panel</p> <p>a</p> <p>b</p>	<p>Twist off the screws used for fixing the handle and valve cover, pull the handle and valve cover upward to remove it.</p> <p>Remove the 3 screws connecting the top panel with the front panel and the right side plate, and then remove the top panel.</p>	 <p>handle</p> <p>top panel</p>
<p>2. Remove grille, panel and rear grill</p> <p>a</p>	<p>Remove the 2 screws connecting the grille and the panel, and then remove the grille.</p>	 <p>top panel</p>

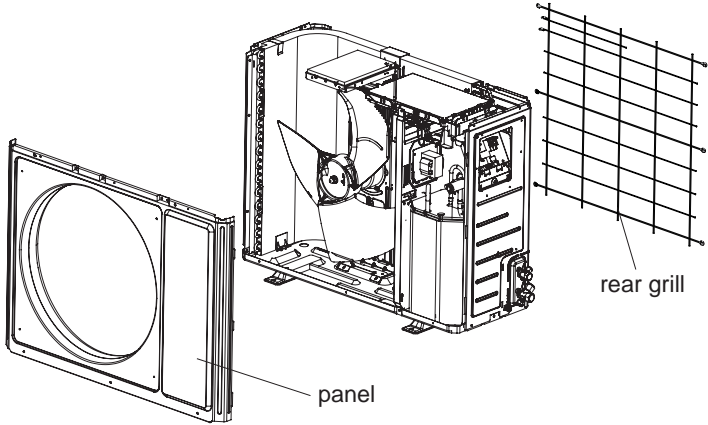
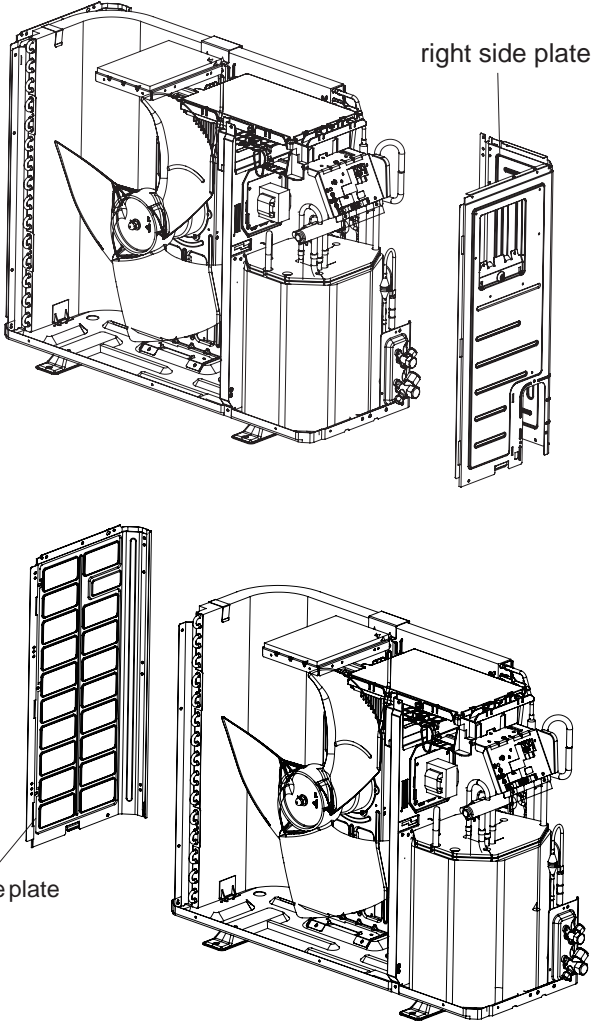
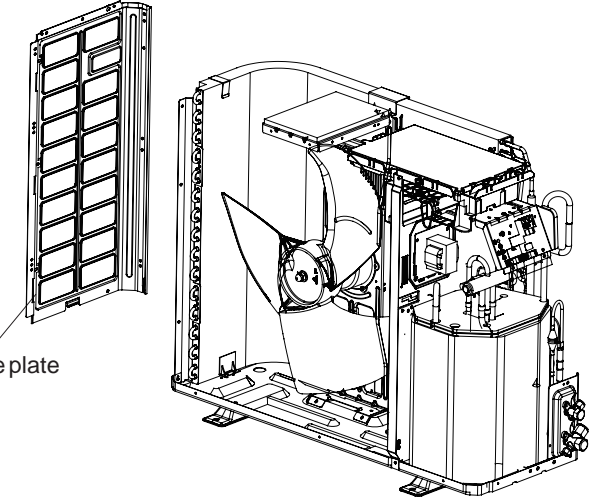
Steps	Procedure	
<p>b</p>	<p>Remove the 5 screws connecting the panel with the chassis and the motor support, and then remove the panel.</p> <p>Remove the 6 screws connecting the left side plate and right side plate and then remove rear grill</p>	 <p>Diagram illustrating the removal of the panel and rear grill. The panel is shown detached from the chassis. The rear grill is shown as a separate grid component.</p>
<p>3. Remove left side plate and right side plate</p>		
<p>a</p>	<p>Remove the screws connecting the right side plate with the chassis, the valve support and the electric box, and then remove the right side plate assy.</p>	 <p>Diagram illustrating the removal of the right side plate and left side plate. The right side plate is shown detached from the chassis. The left side plate is shown as a separate grid component.</p>
<p>b</p>	<p>Remove the screws connecting the left side plate and the chassis, and then remove the left side plate assy.</p>	 <p>Diagram illustrating the removal of the left side plate. The left side plate is shown detached from the chassis.</p>

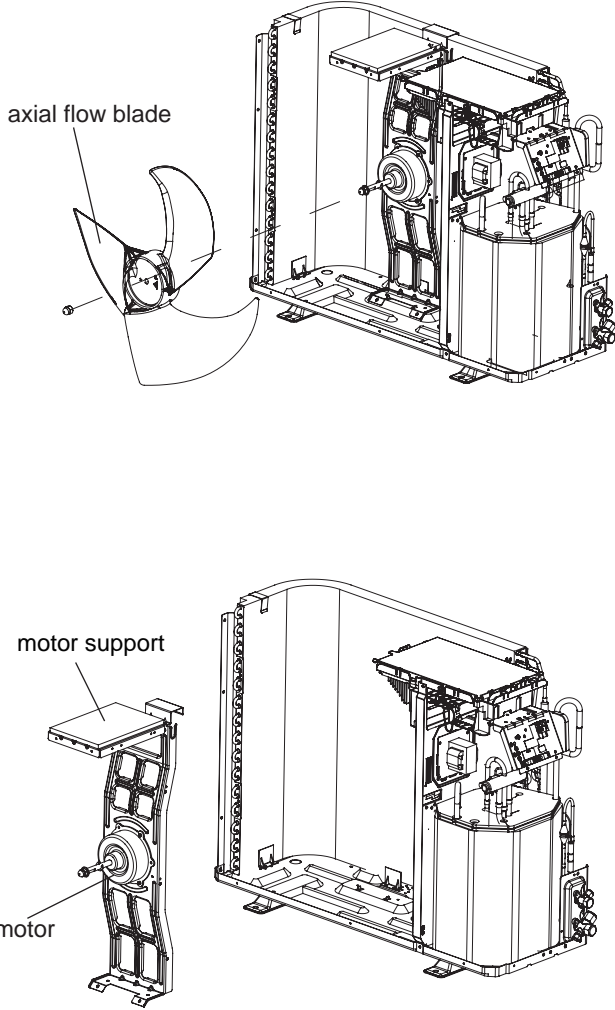
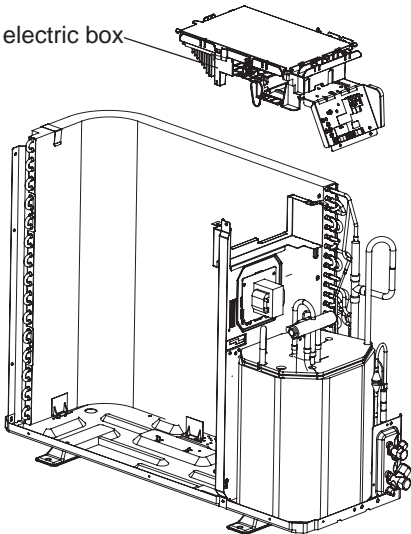
Steps	Procedure
<p>4. Remove fan motor</p> <p>a</p> <p>b</p>	<p>Remove the nuts fixing the blade and then remove the axial flow blade.</p> <p>Remove the 4 tapping screws fixing the motor; disconnect the leading wire insert of the motor and then remove the motor. Remove the 2 tapping screws fixing the motor support and then pull the motor support upwards to remove it.</p>  <p>The diagram for step 4 consists of two parts. The top part shows a close-up of an axial flow blade being removed from the fan assembly, with a label 'axial flow blade' pointing to it. The bottom part shows the motor support being removed from the fan assembly, with labels 'motor support' and 'motor' pointing to the respective parts.</p>
<p>5. Remove electric box</p>	<p>Remove the screws fixing the electric box sub-assy; loosen the wire bundle; pull out the wiring terminals and then pull the electric box upwards to remove it.</p>  <p>The diagram for step 5 shows the electric box sub-assembly being removed from the fan assembly. A label 'electric box' points to the sub-assembly being lifted away from the main unit.</p>

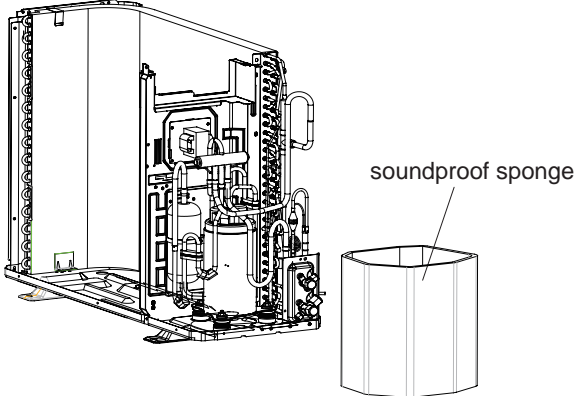
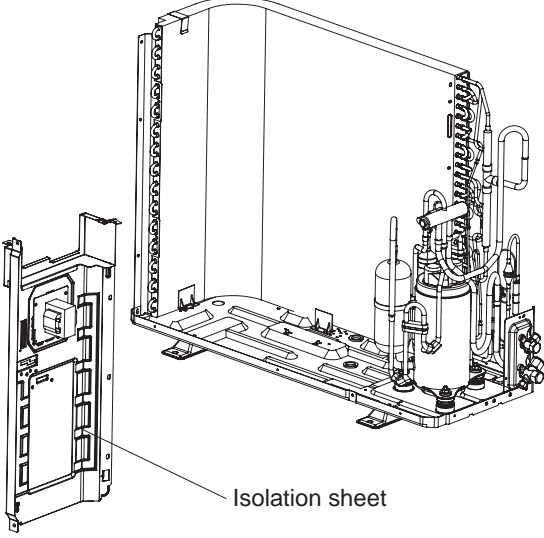
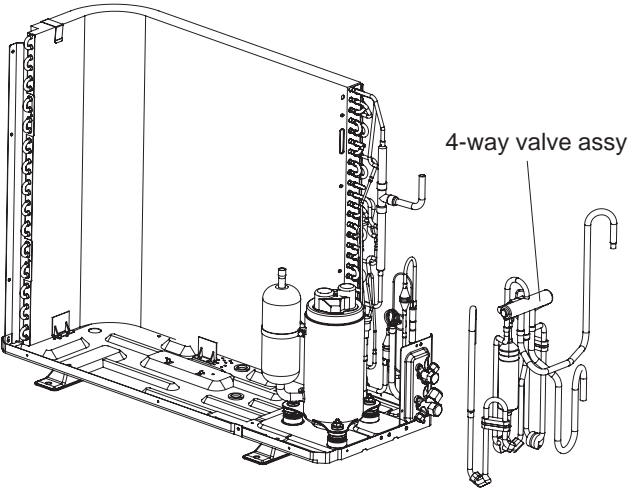
Steps	Procedure	
<p>6.Remove soundproof sponge</p>	<p>Since the piping ports on the soundproof sponge are torn easily, remove the soundproof sponge carefully</p>	 <p>soundproof sponge</p>
<p>7. Remove Isolation sheet</p>	<p>Remove the 3 screws fixing the isolation sheet and then remove the Isolation sheet.</p>	 <p>Isolation sheet</p>
<p>8. Remove 4-way valve assy</p>	<p>Discharge the refrigerant completely;unsolder the pipelines connecting the compressor and the condenser assy,and then remove the 4-way valve assy.</p>	 <p>4-way valve assy</p>

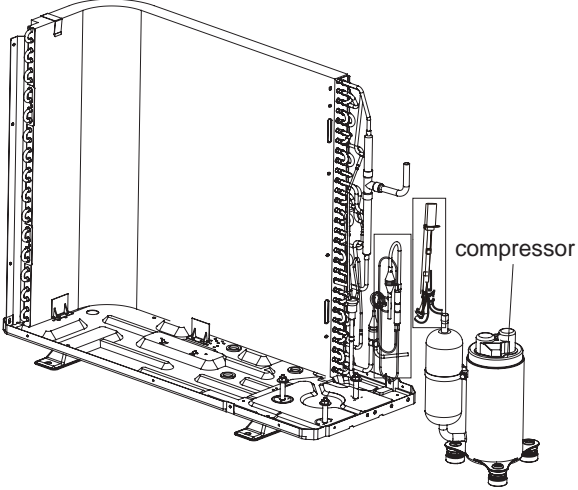
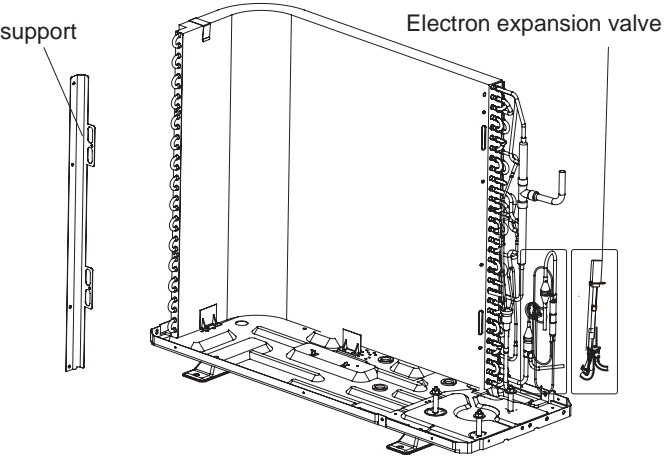
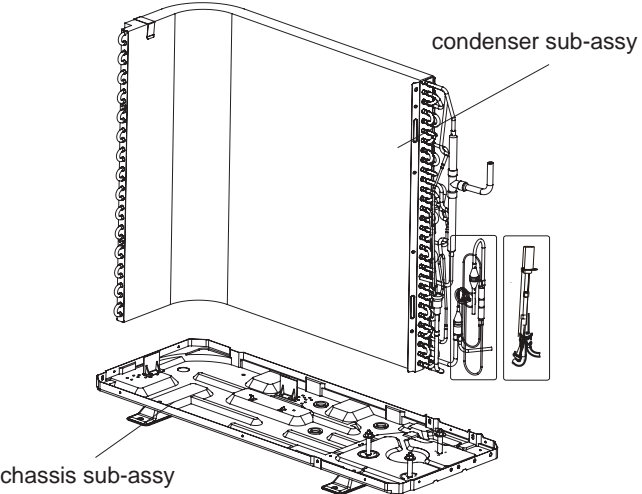
Steps	Procedure
9. Remove compressor	<p data-bbox="224 443 691 497">Remove the 3 foot nuts fixing the compressor and then remove the compressor.</p>  <p data-bbox="1289 497 1414 526">compressor</p>
10. Remove condenser sub-assy	<p data-bbox="126 941 670 1022">a Remove the screws connecting the support (condenser) and condenser assy, and then remove the support (condenser).</p>  <p data-bbox="802 908 878 936">support</p> <p data-bbox="1208 897 1468 926">Electron expansion valve</p> <p data-bbox="126 1421 688 1476">b Remove the chassis sub-assy and condenser sub-assy.</p>  <p data-bbox="1230 1395 1446 1423">condenser sub-assy</p> <p data-bbox="802 1825 976 1854">chassis sub-assy</p>

15K

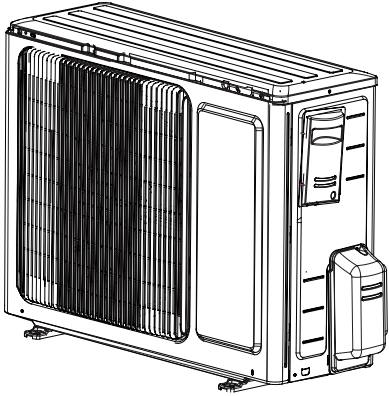
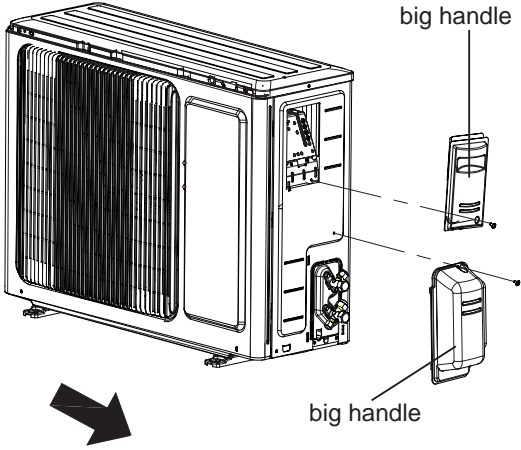
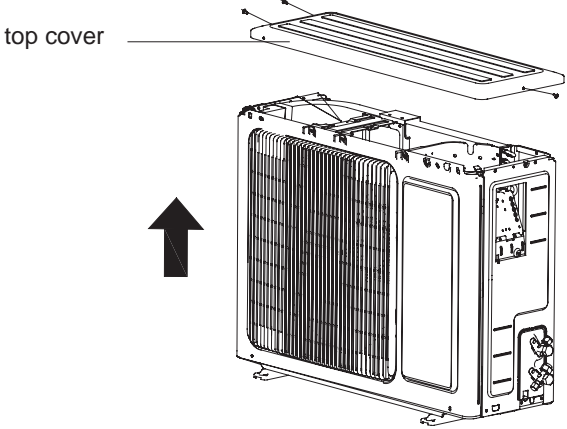
Steps	Procedure
<p>1. Before disassembly</p>	
<p>2. Remove big handle</p>	<p data-bbox="240 974 675 1033">Remove the connection screw fixing the big handle and then remove the handle.</p> 
<p>3. Remove top cover</p>	<p data-bbox="240 1530 683 1644">Remove connection screws connecting the top panel with the front panel and the right side plate, and then remove the top panel.</p> 

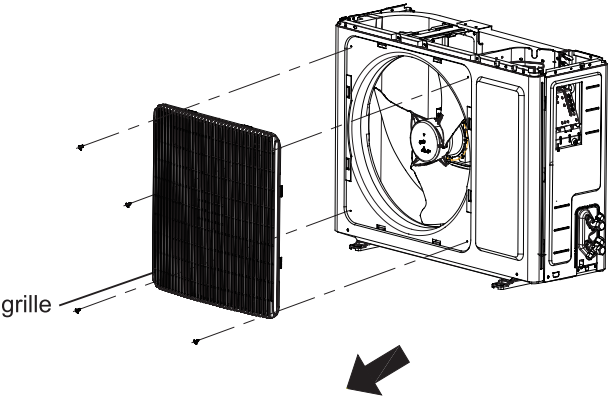
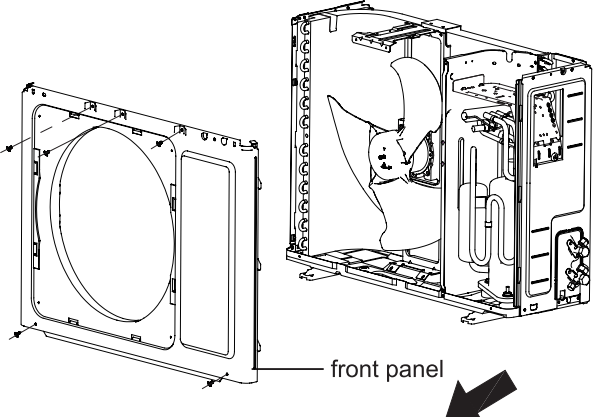
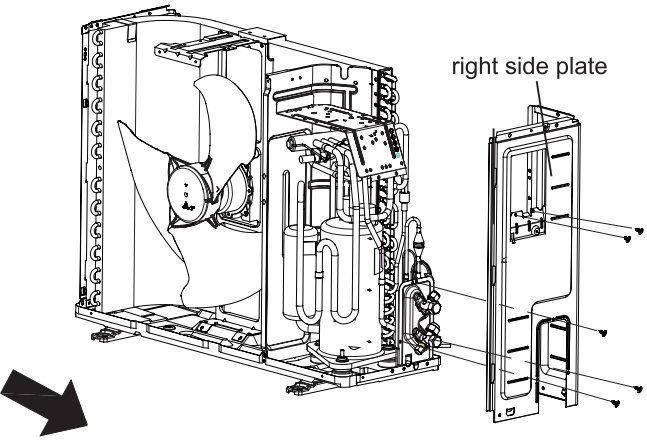
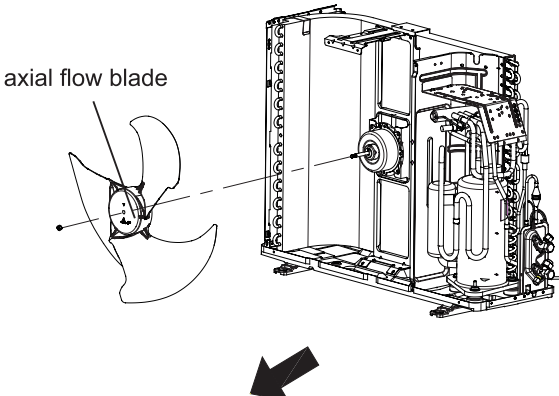
Step	Procedure
<p>4. Remove grille</p>	<p>Remove connection screws between the front grille and the front panel. Then remove the grille.</p>  <p>grille</p>
<p>5. Remove front panel</p>	<p>Remove connection screws connecting the front panel with the chassis and the motor support and then remove the front panel.</p>  <p>front panel</p>
<p>6. Remove right side plate</p>	<p>Remove connection screws connecting the right side plate with the valve support and the electric box. Then remove the right side plate.</p>  <p>right side plate</p>
<p>7. Remove axial flow blade</p>	<p>Remove the nut on the blade and then remove the axial flow blade.</p>  <p>axial flow blade</p>

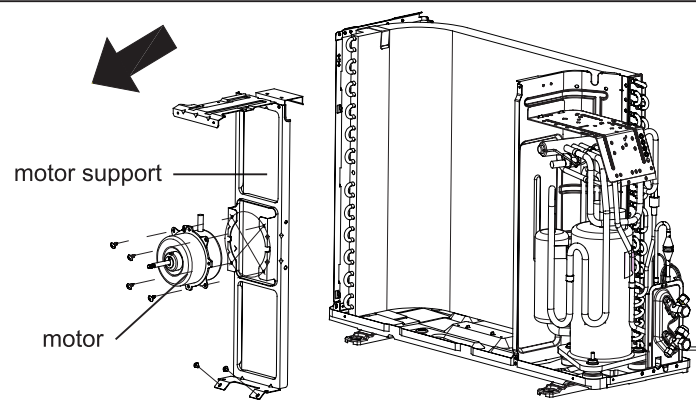
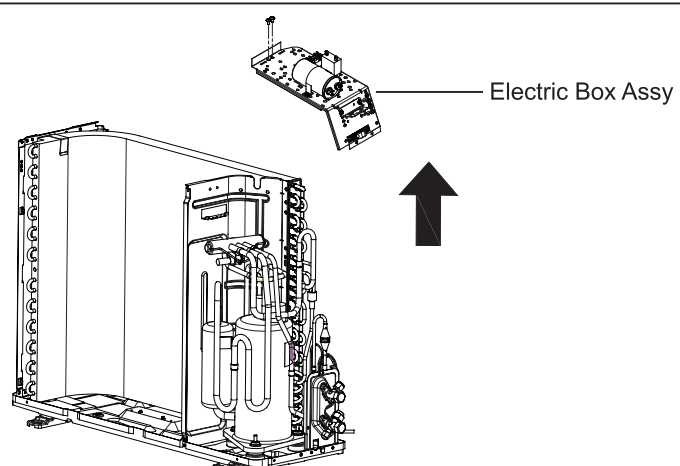
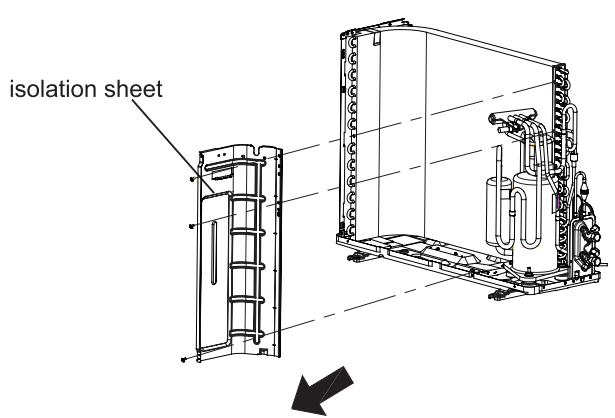
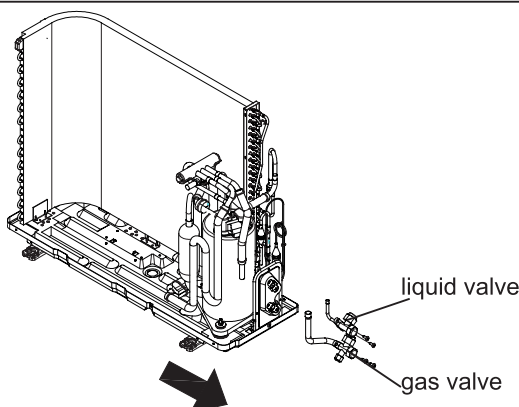
Step	Procedure
<p>8. Remove motor and motor support</p>	<p>Remove the tapping screws fixing the motor and disconnect the leading wire insert of the motor. Then remove the motor. Remove the tapping screws fixing the motor support and lift the motor support to remove it.</p> 
<p>9. Remove Electric Box Assy</p>	<p>Remove screws fixing the electric box subassembly; loosen the wire bundle and unplug the wiring terminals. Then lift the electric box to remove it.</p> 
<p>10. Remove isolation sheet</p>	<p>Remove the screws fixing the isolation sheet and then remove the isolation sheet.</p> 
<p>11. Remove compressor</p>	<p>Unsolder the welding joint connecting the capillary, valves and the outlet pipe of condenser to remove the capillary. Do not block the capillary with welding slag during unsoldering.</p> <p>a</p> 

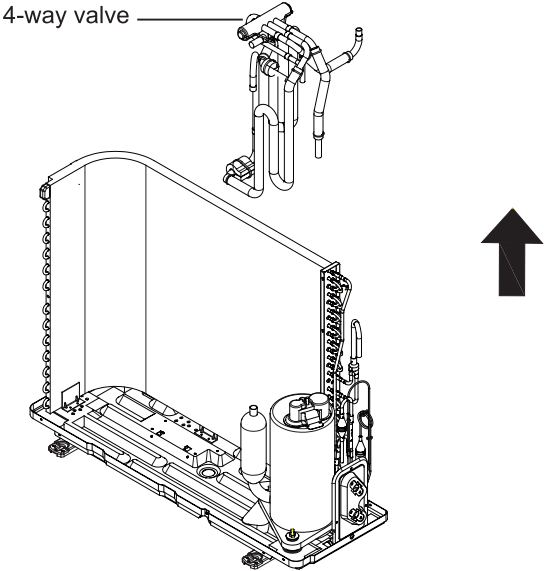
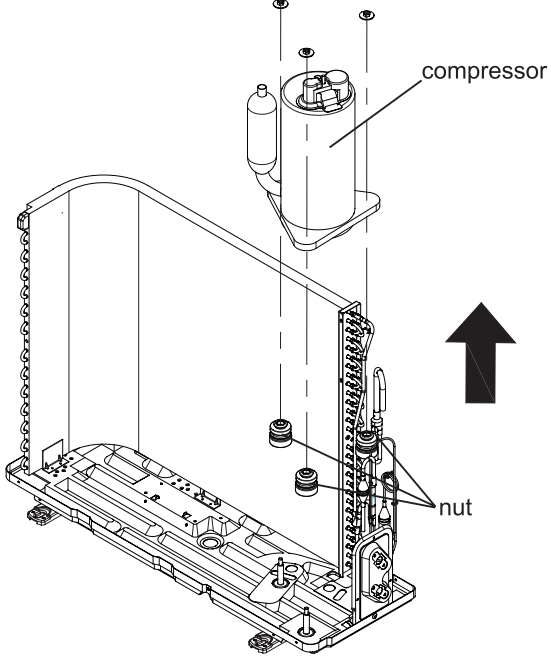
Step	Procedure	Diagram
b	<p>Remove the 2 screws fixing the gas valve and unsolder the welding joint between the gas valve and the air-return pipe to remove the gas valve. (NOTE: Discharge the refrigerant completely before unsoldering; when unsoldering, wrap the gas valve with a wet cloth completely to avoid damage to the valve caused by high temperature).</p> <p>Remove the 2 screws fixing the liquid valve and unsolder the welding joint connecting the liquid valve to the Y-type pipe to remove the liquid valve.</p>	
c	<p>Unsolder pipes connecting with compressor.</p>	
d	<p>Remove the 3 foot nuts on the compressor and then remove the compressor.</p>	

Appendix:

Appendix 1: Reference Sheet of Celsius and Fahrenheit

Conversion formula for Fahrenheit degree and Celsius degree: $T_f = T_c \times 1.8 + 32$

Set temperature

Fahrenheit display temperature (°F)	Fahrenheit (°F)	Celsius(°C)	Fahrenheit display temperature (°F)	Fahrenheit (°F)	Celsius(°C)	Fahrenheit display temperature (°F)	Fahrenheit (°F)	Celsius(°C)
61	60.8	16	69/70	69.8	21	78/79	78.8	26
62/63	62.6	17	71/72	71.6	22	80/81	80.6	27
64/65	64.4	18	73/74	73.4	23	82/83	82.4	28
66/67	66.2	19	75/76	75.2	24	84/85	84.2	29
68	68	20	77	77	25	86	86	30

Ambient temperature

Fahrenheit display temperature (°F)	Fahrenheit (°F)	Celsius(°C)	Fahrenheit display temperature (°F)	Fahrenheit (°F)	Celsius(°C)	Fahrenheit display temperature (°F)	Fahrenheit (°F)	Celsius(°C)
32/33	32	0	55/56	55.4	13	79/80	78.8	26
34/35	33.8	1	57/58	57.2	14	81	80.6	27
36	35.6	2	59/60	59	15	82/83	82.4	28
37/38	37.4	3	61/62	60.8	16	84/85	84.2	29
39/40	39.2	4	63	62.6	17	86/87	86	30
41/42	41	5	64/65	64.4	18	88/89	87.8	31
43/44	42.8	6	66/67	66.2	19	90	89.6	32
45	44.6	7	68/69	68	20	91/92	91.4	33
46/47	46.4	8	70/71	69.8	21	93/94	93.2	34
48/49	48.2	9	72	71.6	22	95/96	95	35
50/51	50	10	73/74	73.4	23	97/98	96.8	36
52/53	51.8	11	75/76	75.2	24	99	98.6	37
54	53.6	12	77/78	77	25			

Appendix 2: Configuration of Connection Pipe

1. Standard length of connection pipe

- 5m, 7.5m, 8m.

2. Min length of connection pipe For the unit with standard connection pipe of 5m, there is no limitation for the min length of connection pipe. For the unit with standard connection pipe of 7.5m and 8m, the min length of connection pipe is 3m.

3. Max length of connection pipe (More details please refer to the specifications)

4. The additional refrigerant oil and refrigerant charging required after prolonging connection pipe

- After the length of connection pipe is prolonged for 10m at the basis of standard length, you should add 5ml of refrigerant oil for each additional 5m of connection pipe.
- The calculation method of additional refrigerant charging amount (on the basis of liquid pipe):
- Basing on the length of standard pipe, add refrigerant according to the requirement as shown in the table. The additional refrigerant charging amount per meter is different according to the diameter of liquid pipe. See Sheet 2.
- Additional refrigerant charging amount = prolonged length of liquid pipe X additional refrigerant charging amount per meter

Additional refrigerant charging amount for R32				
Diameter of connection pipe		Indoor unit throttl	Outdoor unit throttle	
Liquid pipe	Gas pipe	Cooling only, cooling and heating(g / m)	Cooling only(g / m)	Cooling and heating(g / m)
Φ6	Φ9.5 or Φ12	16	12	16
Φ6 or Φ9.5	Φ16 or Φ19	40	12	40
Φ12	Φ19 or Φ22.2	80	24	96
Φ16	Φ25.4 or Φ31.8	136	48	96
Φ19	/	200	200	200
Φ22.2	/	280	280	280

Note: The additional refrigerant charging amount in Sheet 2 is recommended value, not compulsory.

Appendix 3: Pipe Expanding Method

⚠ Note:

Improper pipe expanding is the main cause of refrigerant leakage. Please expand the pipe according to the following steps:

A: Cut the pip

- Confirm the pipe length according to the distance of indoor unit and outdoor unit.
- Cut the required pipe with pipe cutter.

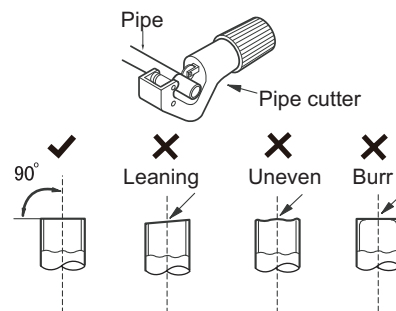

B: Remove the burrs

- Remove the burrs with shaper and prevent the burrs from getting into the pipe.

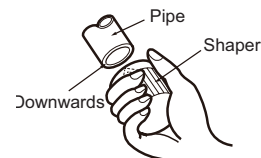

C: Put on suitable insulating pipe

D: Put on the union nut

- Remove the union nut on the indoor connection pipe and outdoor valve; install the union nut on the pipe.

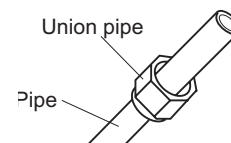

E: Expand the port

- Expand the port with expander.

⚠ Note:

- "A" is different according to the diameter, please refer to the sheet below:

Outer diameter(mm)	A(mm)	
	Max	Min
Φ6 - 6.35 (1/4")	1.3	0.7
Φ9.52 (3/8")	1.6	1.0
Φ12 - 12.7 (1/2")	1.8	1.0
Φ15.8 - 16 (5/8")	2.4	2.2

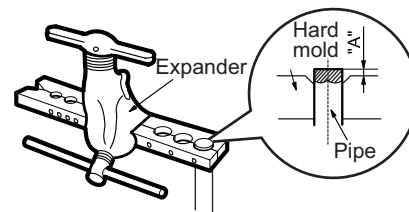

F: Inspection

- Check the quality of expanding port. If there is any blemish, expand the port again according to the steps above.

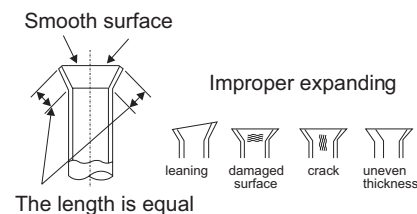

Appendix 4: List of Resistance for Temperature Sensor

Resistance Table of Ambient Temperature Sensor for Indoor and Outdoor (15K)

Temp(°C)	Resistance(kΩ)	Temp(°C)	Resistance(kΩ)	Temp(°C)	Resistance(kΩ)	Temp(°C)	Resistance(kΩ)
-19	138.1	20	18.75	59	3.848	98	1.071
-18	128.6	21	17.93	60	3.711	99	1.039
-17	121.6	22	17.14	61	3.579	100	1.009
-16	115	23	16.39	62	3.454	101	0.98
-15	108.7	24	15.68	63	3.333	102	0.952
-14	102.9	25	15	64	3.217	103	0.925
-13	97.4	26	14.36	65	3.105	104	0.898
-12	92.22	27	13.74	66	2.998	105	0.873
-11	87.35	28	13.16	67	2.896	106	0.848
-10	82.75	29	12.6	68	2.797	107	0.825
-9	78.43	30	12.07	69	2.702	108	0.802
-8	74.35	31	11.57	70	2.611	109	0.779
-7	70.5	32	11.09	71	2.523	110	0.758
-6	66.88	33	10.63	72	2.439	111	0.737
-5	63.46	34	10.2	73	2.358	112	0.717
-4	60.23	35	9.779	74	2.28	113	0.697
-3	57.18	36	9.382	75	2.206	114	0.678
-2	54.31	37	9.003	76	2.133	115	0.66
-1	51.59	38	8.642	77	2.064	116	0.642
0	49.02	39	8.297	78	1.997	117	0.625
1	46.6	40	7.967	79	1.933	118	0.608
2	44.31	41	7.653	80	1.871	119	0.592
3	42.14	42	7.352	81	1.811	120	0.577
4	40.09	43	7.065	82	1.754	121	0.561
5	38.15	44	6.791	83	1.699	122	0.547
6	36.32	45	6.529	84	1.645	123	0.532
7	34.58	46	6.278	85	1.594	124	0.519
8	32.94	47	6.038	86	1.544	125	0.505
9	31.38	48	5.809	87	1.497	126	0.492
10	29.9	49	5.589	88	1.451	127	0.48
11	28.51	50	5.379	89	1.408	128	0.467
12	27.18	51	5.197	90	1.363	129	0.456
13	25.92	52	4.986	91	1.322	130	0.444
14	24.73	53	4.802	92	1.282	131	0.433
15	23.6	54	4.625	93	1.244	132	0.422
16	22.53	55	4.456	94	1.207	133	0.412
17	21.51	56	4.294	95	1.171	134	0.401
18	20.54	57	4.139	96	1.136	135	0.391
19	19.63	58	3.99	97	1.103	136	0.382

Resistance Table of Tube Temperature Sensors for Outdoor and Indoor (20K)

Temp(°C)	Resistance(kΩ)	Temp(°C)	Resistance(kΩ)	Temp(°C)	Resistance(kΩ)	Temp(°C)	Resistance(kΩ)
-19	181.4	20	25.01	59	5.13	98	1.427
-18	171.4	21	23.9	60	4.948	99	1.386
-17	162.1	22	22.85	61	4.773	100	1.346
-16	153.3	23	21.85	62	4.605	101	1.307
-15	145	24	20.9	63	4.443	102	1.269
-14	137.2	25	20	64	4.289	103	1.233
-13	129.9	26	19.14	65	4.14	104	1.198
-12	123	27	18.13	66	3.998	105	1.164
-11	116.5	28	17.55	67	3.861	106	1.131
-10	110.3	29	16.8	68	3.729	107	1.099
-9	104.6	30	16.1	69	3.603	108	1.069
-8	99.13	31	15.43	70	3.481	109	1.039
-7	94	32	14.79	71	3.364	110	1.01
-6	89.17	33	14.18	72	3.252	111	0.983
-5	84.61	34	13.59	73	3.144	112	0.956
-4	80.31	35	13.04	74	3.04	113	0.93
-3	76.24	36	12.51	75	2.94	114	0.904
-2	72.41	37	12	76	2.844	115	0.88
-1	68.79	38	11.52	77	2.752	116	0.856
0	65.37	39	11.06	78	2.663	117	0.833
1	62.13	40	10.62	79	2.577	118	0.811
2	59.08	41	10.2	80	2.495	119	0.77
3	56.19	42	9.803	81	2.415	120	0.769
4	53.46	43	9.42	82	2.339	121	0.746
5	50.87	44	9.054	83	2.265	122	0.729
6	48.42	45	8.705	84	2.194	123	0.71
7	46.11	46	8.37	85	2.125	124	0.692
8	43.92	47	8.051	86	2.059	125	0.674
9	41.84	48	7.745	87	1.996	126	0.658
10	39.87	49	7.453	88	1.934	127	0.64
11	38.01	50	7.173	89	1.875	128	0.623
12	36.24	51	6.905	90	1.818	129	0.607
13	34.57	52	6.648	91	1.736	130	0.592
14	32.98	53	6.403	92	1.71	131	0.577
15	31.47	54	6.167	93	1.658	132	0.563
16	30.04	55	5.942	94	1.609	133	0.549
17	28.68	56	5.726	95	1.561	134	0.535
18	27.39	57	5.519	96	1.515	135	0.521
19	26.17	58	5.32	97	1.47	136	0.509

Resistance Table of Discharge Temperature Sensor for Outdoor (50K)

Temp(°C)	Resistance(kΩ)	Temp(°C)	Resistance(kΩ)	Temp(°C)	Resistance(kΩ)	Temp(°C)	Resistance(kΩ)
-29	853.5	10	98	49	18.34	88	4.75
-28	799.8	11	93.42	50	17.65	89	4.61
-27	750	12	89.07	51	16.99	90	4.47
-26	703.8	13	84.95	52	16.36	91	4.33
-25	660.8	14	81.05	53	15.75	92	4.20
-24	620.8	15	77.35	54	15.17	93	4.08
-23	580.6	16	73.83	55	14.62	94	3.96
-22	548.9	17	70.5	56	14.09	95	3.84
-21	516.6	18	67.34	57	13.58	96	3.73
-20	486.5	19	64.33	58	13.09	97	3.62
-19	458.3	20	61.48	59	12.62	98	3.51
-18	432	21	58.77	60	12.17	99	3.41
-17	407.4	22	56.19	61	11.74	100	3.32
-16	384.5	23	53.74	62	11.32	101	3.22
-15	362.9	24	51.41	63	10.93	102	3.13
-14	342.8	25	49.19	64	10.54	103	3.04
-13	323.9	26	47.08	65	10.18	104	2.96
-12	306.2	27	45.07	66	9.83	105	2.87
-11	289.6	28	43.16	67	9.49	106	2.79
-10	274	29	41.34	68	9.17	107	2.72
-9	259.3	30	39.61	69	8.85	108	2.64
-8	245.6	31	37.96	70	8.56	109	2.57
-7	232.6	32	36.38	71	8.27	110	2.50
-6	220.5	33	34.88	72	7.99	111	2.43
-5	209	34	33.45	73	7.73	112	2.37
-4	198.3	35	32.09	74	7.47	113	2.30
-3	199.1	36	30.79	75	7.22	114	2.24
-2	178.5	37	29.54	76	7.00	115	2.18
-1	169.5	38	28.36	77	6.76	116	2.12
0	161	39	27.23	78	6.54	117	2.07
1	153	40	26.15	79	6.33	118	2.02
2	145.4	41	25.11	80	6.13	119	1.96
3	138.3	42	24.13	81	5.93	120	1.91
4	131.5	43	23.19	82	5.75	121	1.86
5	125.1	44	22.29	83	5.57	122	1.82
6	119.1	45	21.43	84	5.39	123	1.77
7	113.4	46	20.6	85	5.22	124	1.73
8	108	47	19.81	86	5.06	125	1.68
9	102.8	48	19.06	87	4.90	126	1.64

JF00303117



GREE ELECTRIC APPLIANCES, INC. OF ZHUHAI

Add: West Jinji Rd, Qianshan, Zhuhai, Guangdong, China 519070

Tel: (+86-756) 8522218 Fax: (+86-756) 8669426

Email: gree@gree.com.cn [Http://www.gree.com](http://www.gree.com)

HONG KONG GREE ELECTRIC APPLIANCES SALES LIMITED

Add: Unit 2612, 26/F., Miramar Tower 132 Nathan Road, TST, Kowloon, HK

Tel: (852) 31658898 Fax: (852) 31651029

For product improvement, specifications and appearance in this manual are subject to change without prior notice.