

AIR TO WATER HEAT PUMP

VERSATI II SERIES

(GC201308-I)

TER CONDITIONERS GREE MAKING BETTER CONDITIONERS GREE MAKING BETTER CONDITIONERS GREE MAKING BETTER COND

TECHNICAL SALES GUIDE-50Hz
CAPACITY RANGE:6~16kW
SUPER HIGH AMBIENT OPERATION TO 48 °C

TER CON MAKING BI ONERS G BETTER ERS GREE MAKING BETTER CONDIT



R410A



CONTENTS

MODELS LIST	3
NOMENCLATURE	4
BASIC SYSTEM CONFIGURATION.....	5
FEATURES	8
SPECIFICATION.....	9
PERFORMANCE CORRECTION.....	13
CAPACITY TABLES.....	15
ELECTRICAL DATA	16
FIELD WIRING DIAGRAM.....	17
INSTALLATION	19
ACCESSORIES	25

1 MODELS LIST

➔ 1.1 Air to Water Heat Pump

Nominal Capacity	Model		Power Supply
Btu/h	Refrigerant	Model Name	V,Ph,Hz
20400	R410A	GRS-CQ6.0Pd/NaB-K	220-240V,~,50Hz
27300		GRS-CQ8.0Pd/NaB-K	
34100		GRS-CQ10Pd/NaB-K	
40900		GRS-CQ12Pd/NaB-K	
47800		GRS-CQ14Pd/NaB-K	
54600		GRS-CQ16Pd/NaB-K	
40900		GRS-CQ12Pd/NaB-M	380-415V,3N~,50Hz
47800		GRS-CQ14Pd/NaB-M	
54600		GRS-CQ16Pd/NaB-M	

➔ 1.2 Water Tank

Model	Litre	Remarks
Model Name	L	Inner coil
SXVD200LCJ/A-K	200	Only an inner coil connected to master unit ;
SXVD200LCJ2/A-K		An inner coil connected to master unit; another connected to other heat source ;
SXVD300LCJ/A-K	300	Only an inner coil connected to master unit ;
SXVD300LCJ2/A-K		An inner coil connected to master unit; another connected to other heat source ;
SXVD200LCJ/A-M	200	Only an inner coil connected to master unit ;
SXVD200LCJ2/A-M		An inner coil connected to master unit; another connected to other heat source ;
SXVD300LCJ/A-M	300	Only an inner coil connected to master unit;
SXVD300LCJ2/A-M		An inner coil connected to master unit; another connected to other heat source ;
SXVD200LCJ/A-H	200	Only an inner coil connected to master unit;
SXVD200LCJ2/A-H		An inner coil connected to master unit; another connected to other heat source ;
SXVD300LCJ/A-H	300	Only an inner coil connected to master unit;
SXVD300LCJ2/A-H		An inner coil connected to master unit; another connected to other heat source ;

2 NOMENCLATURE

➔ 2.1 Nomenclature of the Main Unit

G	RS	-	C	Q	16	Pd	/	Na	B	-	K	(O)
1	2		3	4	5	6		7	8		9	10

NO.	Description	Options
1	GREE	G
2	Heat Pump Water Heater	RS
3	Heating Mode	S= Static; C=Circulating
4	Function	Q=Multi-function; Omit=Single-function
5	Nominal Heating Capacity	6=6.0kW; 8=8.0kW;10=10kW; 12=12kW; 14=14kW; 16=16kW
6	Compressor Style	Pd=DC Inverter; Omit=On/Off
7	Refrigerant	Na=R410A
8	Design Serial Number	B,C,D.....
9	Power Supply	K=220-240V,~,50Hz; M=380-415V,3N~,50Hz; H=380V,3N~,60Hz
10	Indoor and Outdoor Unit Code	I=Indoor unit; O=Outdoor unit

➔ 2.2 Nomenclature of the Water Tank

SX	V	D	300	L	C	J2	/	A	-	K
1	2	3	4	5	6	7		8		9

NO.	Description	Options
1	Symbol of Heat Pump Water Tank	SX
2	Tank Type	Omit-Common heat pump water tank; V-Heat pump water tank for multi VRF system
3	Function Code	Omit-No electric heating function; D-Electric heating function available
4	Nominal Water Tank Volume	300=300L
5	Structure Type	B-Wall mounted type; L-Floor standing type
6	Bearing	Omit-Non-bearing water tank; C-Bearing water tank
7	Type of Heat Exchange Tube	Omit-No heat exchanger; J-Inner coil static heating(J-Single coil; J2-Double coils); JW-Outer coil static heating
8	Serial Number	A,B,C.....
9	Power Supply	K=220-240V,~,50Hz; M=380-415V,3N~,50Hz; H=380V,3N~,60Hz

3 BASIC SYSTEM CONFIGURATION

3.1 System Connection Diagram

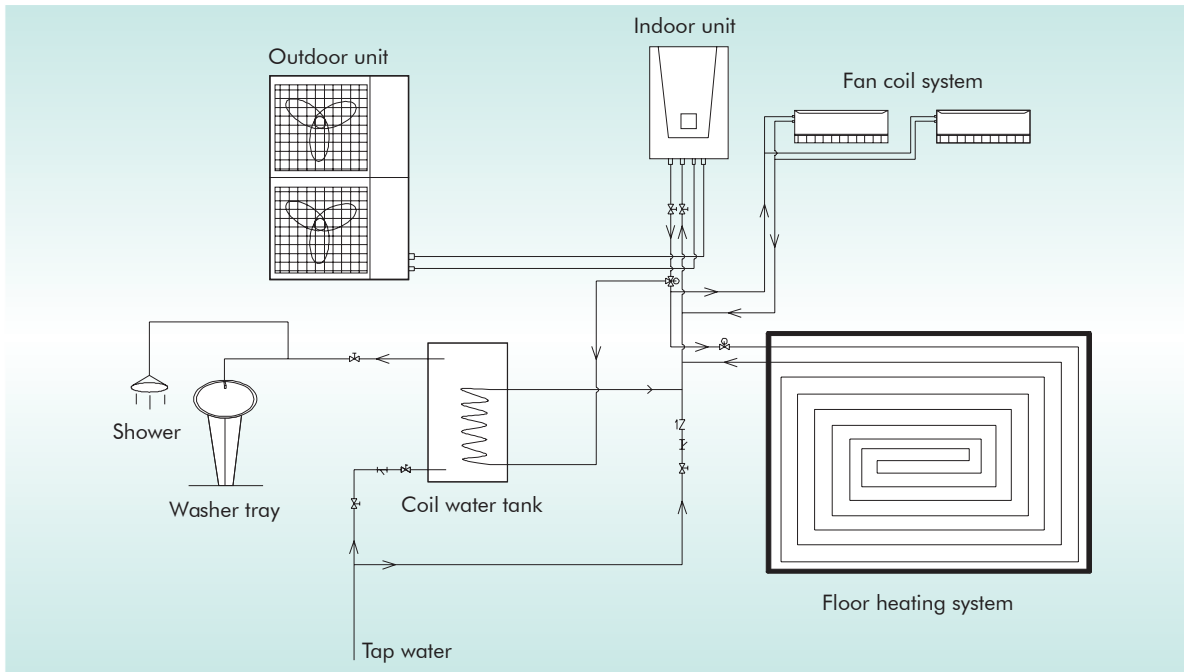

3.2 Installation Demonstration

CASE 1: Connecting Under-floor coil for heating and cooling

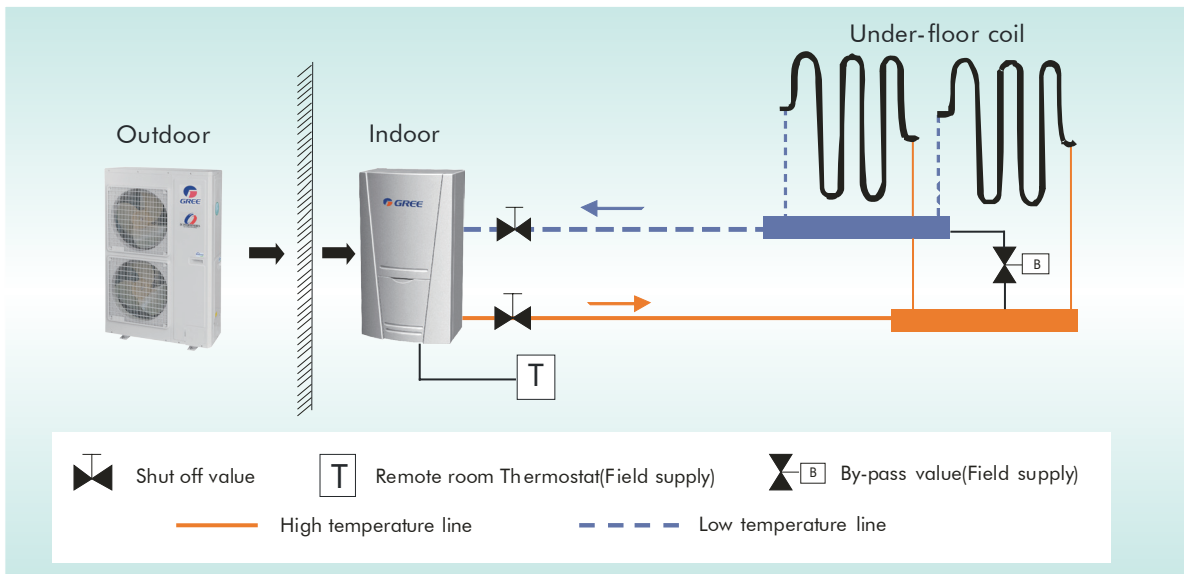

Note

- 1.Type of thermostat and specification should be complied with installation of this manual;
- 2.By pass valve must be installed to secure enough water flow rate,and by pass valve should be installed at the collector.

CASE 2: Connecting Sanitary Water Tank

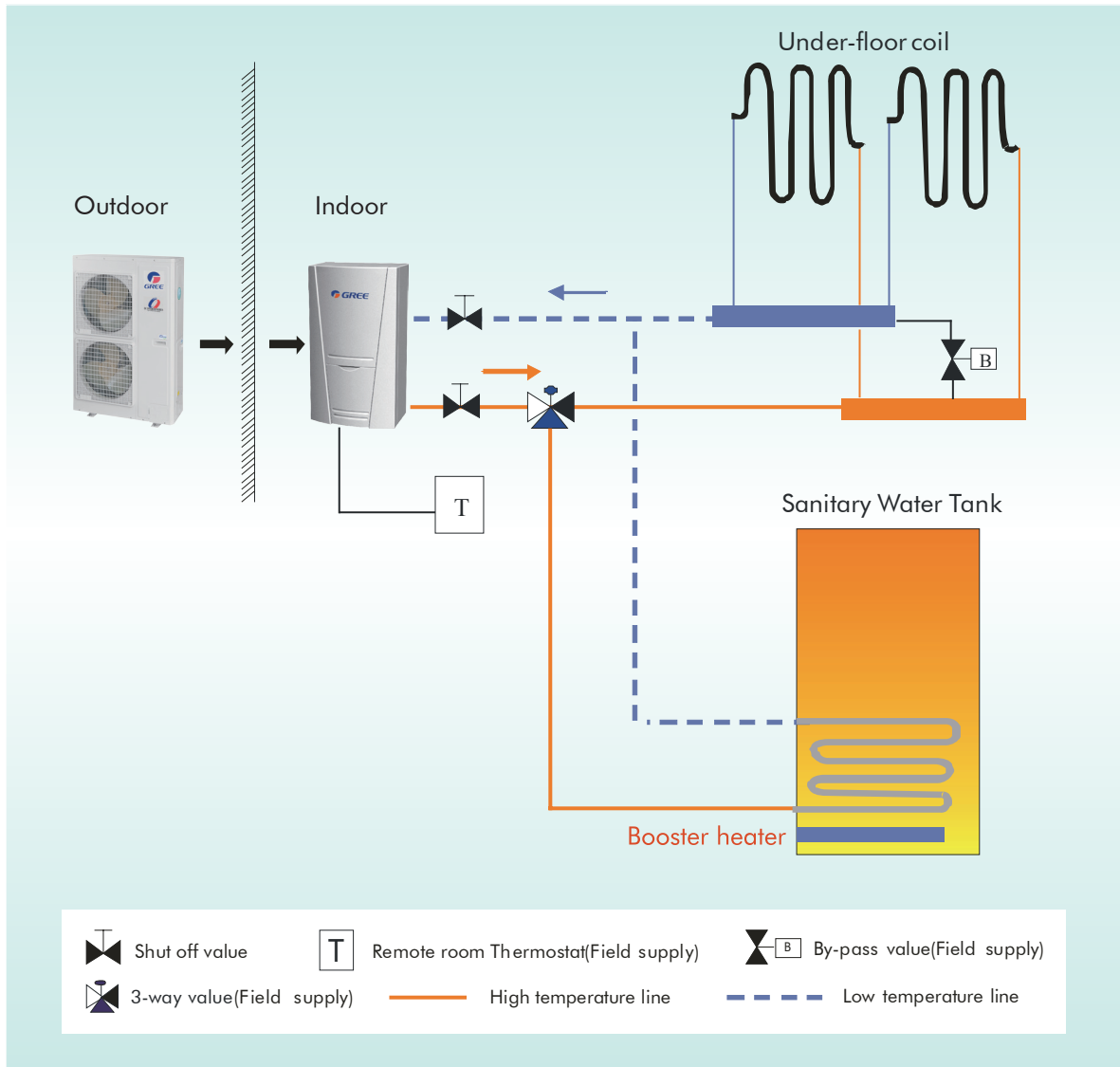

Note

1. In this case, three-way valve should be installed and should be complied with installation of this manual;
2. Sanitary water tank should be equipped with internal electric heater to secure enough heat energy in the very cold days.

CASE 3: Connecting Sanitary Water Tank and Heat Emitters for heating and Cooling

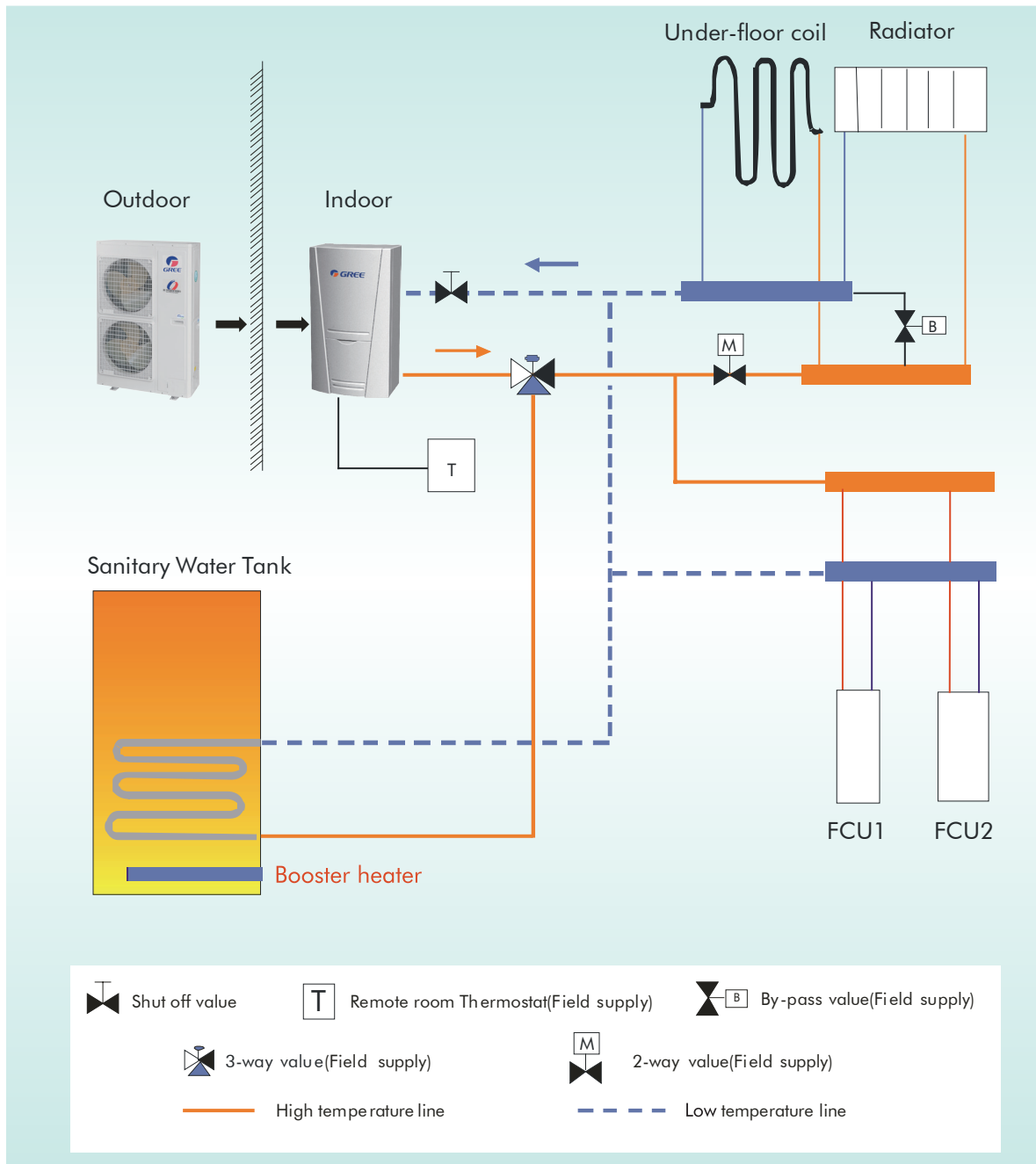

Note

Two-way valve is very important to prevent dew condensation on the floor and Radiator while cooling mode.

4 FEATURES

➔ 4.1 Outdoor Unit

Inverter Control;
 BLDC Fan Motor Control;
 DC Inverter Compressor;
 Soft Operation by Sine Wave;
 PFC Step-up Technology;
 High Efficiency Fan & Grille
 High Volume Axial Fan Makes Powerful Cooling and Maintains System Stable;
 Deluxe Controller and Smart Control
 Emergency Operation Mode;
 Central Control;
 Weekly Programmable;
 Quick Water Heating Mode;
 Disinfection Operation;
 Holiday Mode;
 Silent Mode;
 Forced Operation Mode;
 Weather-Dependent Operation;
 Energy-saving and High Efficiency;
 New Refrigerant and Friendly to Earth;
 Floor Commissioning;
 Air removal of the water system.

➔ 4.2 Indoor Unit

Compact Sizes : 900×500×324mm(W×D×H);
 Deluxe Design;
 High COP Plate Heat Exchanger;
 High Efficient Pump;

➔ 4.3 Sanitary Water Tank

Installation in Water Heating System;
 Rapid Storage and Continuous Delivery;
 High Efficiency for Low Running Costs;
 CFC Free Insulation;
 Stainless Steel Tank and Coil;
 Magnesium Anode;
 Complete, Easy to Use and Maintain;
 Double Coil and Double Temperature Sensor Design;

5 SPECIFICATION

Due to continues improvement on the products, the specifications listed above are subject to change without notice, and the ones on the products nameplate should be referred to as final.

5.1 Outdoor Unit

Model	GRS-CQ6.0Pj/NaB-K(O)	GRS-CQ8.0Pj/NaB-K(O)	GRS-CQ10Pd/NaB-K(O)	GRS-CQ12Pd/NaB-K(O)	GRS-CQ14Pd/NaB-K(O)		
Capacity*1	Cooling (floor cooling)	5.7	9.5	11	12.5	13.5	
	Heating (floor heating)	6.5	9	10	12.5	13.5	
Power Input*1	Cooling (floor cooling)	1.63	2.57	3.24	3.57	4.09	
	Heating (floor heating)	1.57	2.17	2.44	2.81	3.07	
EER/COP*1	3.5/4.15					3.3/4.4	
Capacity*2	Cooling (for Fan coil)	5	7	8.5	9.5	10	
	Heating (Fan coil or Radiator)	5.8	8.5	9	11	12	
Power Input*2	Cooling (for Fan coil)	1.85	2.59	3.15	3.39	3.57	
	Heating (Fan coil or Radiator)	1.9	2.79	2.81	3.14	3.48	
EER/COP*2	2.7/3.05					2.8/3.45	
Refrigerant charge volume	1.7					3.2	
Sanitary water Temperature	40~80					40~80	
Sound Pressure Level	cooling	57	57	57	55	55	
	heating	59	59	59	57	57	
Connecting pipe	Gas	φ1/2(12.7)					φ5/8(15.9)
	Liquid	φ1/4(6.35)					φ3/8(9.52)
Dimensions (W×D×H)	Outline	921×427×791					900×412×1345
	Packaged	1065×485×840					998×458×1515
Net weight/Gross weight	66/71					106/118	
Loading quantity	40GP	96					52
	40HQ	144					52

Model		GRS-CQ16Pd/NaB-K(O)	GRS-CQ12Pd/NaB-M(O)	GRS-CQ14Pd/NaB-M(O)	GRS-CQ16Pd/NaB-M(O)
Capacity*1	Cooling (floor cooling)	14.5	14	15.5	15
	Heating (floor heating)	15.5	13	14	16
Power Input*1	Cooling (floor cooling)	4.53	4.12	4.63	4.62
	Heating (floor heating)	3.78	2.86	3.18	3.9
EER/COP*1		3.2/4.1	3.4/4.55	3.35/4.4	3.25/4.1
Capacity*2	Cooling (for Fan coil)	10.5	10.5	11	11.5
	Heating (Fan coil or Radiator)	14	11.5	12	14.5
Power Input*2	Cooling (for Fan coil)	3.96	3.56	3.93	4.26
	Heating (Fan coil or Radiator)	4	2.95	3.38	4.03
EER/COP*2		2.65/3.5	2.95/3.9	2.8/3.55	2.7/3.6
Refrigerant charge volume		3.2	3.4	3.4	3.4
Sanitary water Temperature		40~80	40~80	40~80	40~80
Sound Pressure Level	cooling	57	55	55	57
	heating	58	57	57	58
Connecting pipe	Gas	φ5/8(15.9)	φ5/8(15.9)	φ5/8(15.9)	φ5/8(15.9)
	Liquid	φ3/8(9.52)	φ3/8(9.52)	φ3/8(9.52)	φ3/8(9.52)
Dimensions (W×D×H)	Outline	900×412×1345	900×412×1345	900×412×1345	900×412×1345
	Packaged	998×458×1515	998×458×1515	998×458×1515	998×458×1515
Net weight/Gross weight		106/118	108/120	108/120	108/120
Loading quantity	40GP	52	52	52	52
	40HQ	52	52	52	52

Note

¹ Capacities and power inputs are based on the following conditions:

- ① Cooling conditions: Indoor Water Temperature 23°C/18°C; Outdoor Air Temperature 35°CDB/24°C WB;
- ② Heating conditions: Indoor Water Temperature 30°C/35°C; Outdoor Air Temperature 7°C DB/6°CWB;
- ③ Standard piping length 7.5m

² Capacities and power inputs are based on the following conditions;

- ① Cooling conditions: Indoor Water Temperature 12°C/7°C; Outdoor Air Temperature 35°CDB/24°C WB;
- ② Heating conditions: Indoor Water Temperature 40°C/45°C; Outdoor Air Temperature 7°C DB/6°CWB;
- ③ Standard piping length 7.5m

5.2 Indoor Unit

Model	GRS-CQ6.0Pd/NaB-K(I)	GRS-CQ8.0Pd/NaB-K(I)	GRS-CQ10Pd/NaB-K(I)	GRS-CQ12Pd/NaB-K(I)	GRS-CQ14Pd/NaB-K(I)	
Power Supply	V/Ph/Hz 1/220-240/50	1/220-240/50	1/220-240/50	1/220-240/50	1/220-240/50	
Norminal input	W 3200	6200	6200	6200	6200	
	°C 7~25	7~25	7~25	7~25	7~25	
Leaving water temperature	°C 18~25	18~25	18~25	18~25	18~25	
	°C	25~55(High temperature cycle)				
Heating*2	°C	25~45(Low temperature cycle)				
Type	Water-cooled	Water-cooled	Water-cooled	Water-cooled	Water-cooled	
Nr. of speed	3	3	3	3	3	
Power input	W 200	200	200	200	200	
Water flow limit	LPM 7.5	7.5	7.5	7.5	7.5	
Operation	Automatic	Automatic	Automatic	Automatic	Automatic	
Steps	2	2	2	2	2	
Capacity	kW 3	3	3	3	3	
Combination	1.5+1.5	3+3	3+3	3+3	3+3	
Power input	Ph/V/Hz 1/230/50	1/230/50	1/230/50	1/230/50	1/230/50	
Sound pressure level	dB(A) 31	31	31	31	31	
Connecting pipe	Gas inch(mm) φ1/2(12.7)	φ5/8(15.9)	φ5/8(15.9)	φ5/8(15.9)	φ5/8(15.9)	
	Liquid inch(mm) φ1/4(6.35)	φ3/8(9.52)	φ3/8(9.52)	φ3/8(9.52)	φ3/8(9.52)	
Dimensions (W×D×H)	Outline mm 900x500x324	900x500x324	900x500x324	900x500x324	900x500x324	
	Packaged mm 1040×605×380	1040×605×380	1040×605×380	1040×605×380	1040×605×380	
Net weight/Gross weight	kg 52/62	52/62	52/62	57/66	57/66	
Loading quantity	40'GP/40'HQ -	205/246	205/246	205/246	205/246	

Model		GRS-CQ16Pd/NaB-K(I)	GRS-CQ12Pd/NaB-M(I)	GRS-CQ14Pd/NaB-M(I)	GRS-CQ16Pd/NaB-M(I)
Power Supply	V/Ph/Hz	1/220-240/50	3/380-415/50	3/380-415/50	3/380-415/50
Normal input	W	6200	6200	6200	6200
Leaving water temperature	Cooling* ¹	7~25	7~25	7~25	7~25
	Cooling* ²	18~25	18~25	18~25	18~25
	Heating* ¹		25~55(High temperature cycle)		
	Heating* ²		25~45(Low temperature cycle)		
Type	-	Water-cooled	Water-cooled	Water-cooled	Water-cooled
Pump	Nr. of speed	3	3	3	3
	Power input	200	200	200	200
	Water flow limit	7.5	7.5	7.5	7.5
	Operation	Automatic	Automatic	Automatic	Automatic
Electric Heater	Steps	2	1	1	1
	Capacity	3	6	6	6
	Combination	3+3	6	6	6
	Power input	Ph/V/Hz	1/230/50	3/400/50	3/400/50
Sound pressure level	dB(A)	31	31	31	31
Connecting pipe	Gas	φ5/8(15.9)	φ5/8(15.9)	φ5/8(15.9)	φ5/8(15.9)
	Liquid	φ3/8(9.52)	φ3/8(9.52)	φ3/8(9.52)	φ3/8(9.52)
Dimensions (W×D×H)	Outline	900x500x324	900x500x324	900x500x324	900x500x324
	Packaged	1040×605×380	1040×605×380	1040×605×380	1040×605×380
Net weight/Gross weight	kg	57/66	57/66	57/66	57/66
Loading quantity	40'GP/40'HQ	205/246	205/246	205/246	205/246

Note

- ¹ For FCU
- ² For Floor

➔ 5.3 Water Tank

Model		SXVD200LCJ/A-K SXVD200LCJ/A-M SXVD200LCJ/A-H	SXVD200LCJ2/A-K SXVD200LCJ2/A-M SXVD200LCJ2/A-H	SXVD300LCJ/A-K SXVD300LCJ/A-M SXVD300LCJ/A-H	SXVD300LCJ2/A-K SXVD300LCJ2/A-M SXVD300LCJ2/A-H
Water Tank Volume	L	200		300	
Electric Heater Power	W	3000			
Connection Pipe	Cool Water Inlet	inch	1/2" Female BSP		
	Hot Water Outlet	inch	1/2" Female BSP		
	Circulation Water Inlet	inch	3/4" Female BSP		
	Circulation Water Outlet	inch	3/4" Female BSP		
Outline Dimension (ΦD×H)	mm	540×1595		620×1620	
Net Weight	kg	68	71	82	87

6 PERFORMANCE CORRECTION

➔ 6.1 Correction of Temperature

Cooling Capacity Correction

GRS-CQ6.0Pd/NaB-K, GRS-CQ8.0Pd/NaB-K, GRS-CQ10Pd/NaB-K, GRS-CQ12Pd/NaB-K, GRS-CQ14Pd/NaB-K, GRS-CQ16Pd/NaB-K, GRS-CQ12Pd/NaB-M, GRS-CQ14Pd/NaB-M, GRS-CQ16Pd/NaB-M:

Leaving Chilled Water °C(°F)	Performance correction				
	Ambient Temperature °C(°F)				
	25(77)	30(86)	35(95)	40(104)	45(113)
5(41.0)	0.995	0.955	0.905	0.855	0.805
6(42.8)	1.045	1.005	0.955	0.905	0.855
7(44.6)	1.090	1.050	1.000	0.950	0.900
8(46.4)	1.145	1.102	1.052	1.000	0.950
9(48.2)	1.190	1.150	1.100	1.050	1.002
10(50.0)	1.245	1.200	1.150	1.100	1.050
11(51.8)	1.290	1.250	1.202	1.152	1.102
12(53.6)	1.340	1.300	1.252	1.200	1.152
13(55.4)	1.390	1.350	1.302	1.252	1.202
14(57.2)	1.442	1.402	1.350	1.302	1.252
15(59.0)	1.490	1.450	1.400	1.350	1.302
18(64.4)	1.539	1.502	1.451	1.402	1.350

Computer of actual cooling capacity:

Actual cooling capacity = nominal cooling capacity × cooling capacity correction coefficient.

heating Capacity Correction

GRS-CQ6.0Pd/NaB-K, GRS-CQ8.0Pd/NaB-K, GRS-CQ10Pd/NaB-K, GRS-CQ12Pd/NaB-K, GRS-CQ14Pd/NaB-K, GRS-CQ16Pd/NaB-K, GRS-CQ12Pd/NaB-M, GRS-CQ14Pd/NaB-M, GRS-CQ16Pd/NaB-M:

Performance correction									
Outflow Heated Water °C(°F)	Ambient Temperature °C(°F)								
	-15(5)	-10(14)	-5(23)	0(32)	5(41.0)	10(50.0)	15(59.0)	20(68.4)	25(77.4)
30(86)	0.81	0.91	1.00	1.10	1.18	1.26	1.35	1.41	1.45
35(95)	0.74	0.84	0.93	1.03	1.11	1.19	1.28	1.36	1.41
40(104)	0.67	0.77	0.87	0.96	1.04	1.12	1.20	1.25	1.31
45(113)	0.60	0.70	0.80	0.89	0.97	1.05	1.13	1.19	1.25
50(122)	0.53	0.63	0.73	0.82	0.90	0.98	1.06	1.11	1.18
55(131)	0.46	0.56	0.66	0.74	0.83	0.90	0.98	1.05	1.10

Computer of actual heating capacity:

Actual heating capacity = nominal heating capacity × heating capacity correction coefficient.



6.2 Correction of Connection Piping (Applied to Combined Unit)

Total Piping Length(Actual Length)			Correction Factor					
			7.5m	10m	15m	20m	25m	30m
Height between Indoor and Outdoor Unit	The Indoor Unit below the Outdoor Unit	0m	1.0	0.98	0.96	0.94	0.92	0.9
		5m	1.0	0.97	0.95	0.93	0.91	0.89
		10m	-	0.96	0.94	0.92	0.90	0.88
		15m	-	-	0.93	0.91	0.89	0.87
	The Outdoor Unit below the Indoor Unit	0m	1.0	0.98	0.96	0.94	0.92	0.9
		5m	1.0	0.98	0.96	0.94	0.92	0.9
		10m	-	0.98	0.96	0.94	0.92	0.9
		15m	-	-	0.96	0.94	0.92	0.9

7 CAPACITY TABLES

Model	DB/WB(°C)	Floor heating water outlet temp 35°C			Fan coil water outlet temp 45°C			Radiator water outlet 55°C		
		Heating capacity (kW)	Power input (kW)	COP	Heating capacity (kW)	Power input (kW)	COP	Heating capacity (kW)	Power input (kW)	COP
GRS-CQ6.0Pd/ NaB-K	7/6	6.50	1.56	4.15	5.80	1.90	3.05	4.55	1.94	2.35
	2/1	4.90	1.49	3.30	3.99	1.54	2.60	3.63	1.90	1.91
	-7/-8	3.57	1.32	2.71	3.14	1.47	2.14	2.92	1.77	1.65
	-15/-16	2.64	1.24	2.12	2.39	1.38	1.74	2.09	1.67	1.25
GRS-CQ8.0Pd/ NaB-K	7/6	9.00	2.17	4.15	8.50	2.78	3.05	6.67	2.89	2.31
	2/1	6.63	2.01	3.30	5.88	2.24	2.62	5.32	2.82	1.88
	-7/-8	4.82	1.74	2.76	4.61	2.19	2.10	4.29	2.63	1.63
	-15/-16	3.56	1.66	2.14	3.51	2.11	1.67	3.10	2.52	1.23
GRS-CQ10Pd/ NaB-K	7/6	10.00	2.44	4.10	9.00	2.80	3.20	7.23	3.12	2.32
	2/1	7.66	2.36	3.25	6.32	2.40	2.63	5.65	2.99	1.89
	-7/-8	5.85	2.09	2.80	5.21	2.76	1.89	4.67	2.82	1.65
	-15/-16	4.33	1.99	2.18	4.19	2.65	1.58	3.36	2.67	1.26
GRS-CQ12Pd/ NaB-K	7/6	12.50	2.80	4.45	11.00	3.14	3.50	10.20	3.90	2.60
	2/1	8.48	2.62	3.24	7.81	2.98	2.62	7.78	3.67	2.12
	-7/-8	6.87	2.60	2.64	6.05	2.76	2.19	6.01	3.53	1.70
	-15/-16	5.34	2.58	2.07	4.90	2.85	1.72	4.31	3.33	1.29
GRS-CQ14Pd/ NaB-K	7/6	13.50	3.07	4.40	12.00	3.48	3.45	11.50	4.42	2.60
	2/1	9.04	2.72	3.32	8.26	3.09	2.67	8.12	3.77	2.15
	-7/-8	7.55	2.67	2.83	6.61	2.86	2.31	6.24	3.52	1.77
	-15/-16	5.68	2.54	2.23	5.12	2.86	1.79	4.57	3.32	1.38
GRS-CQ16Pd/ NaB-K	7/6	15.50	3.78	4.10	14.00	4.00	3.50	12.95	4.88	2.65
	2/1	9.30	2.97	3.13	8.59	3.29	2.61	9.05	4.53	2.00
	-7/-8	8.57	3.39	2.53	8.04	3.53	2.28	7.29	4.37	1.67
	-15/-16	6.35	3.23	1.97	5.96	3.42	1.74	5.27	3.82	1.38
GRS-CQ12Pd/ NaB-M	7/6	13.00	2.85	4.55	11.50	2.95	3.90	11.00	3.55	3.10
	2/1	8.66	2.70	3.21	8.03	3.06	2.62	8.21	4.02	2.04
	-7/-8	6.84	2.65	2.58	6.25	3.19	1.96	6.45	3.88	1.66
	-15/-16	5.36	2.59	2.07	4.92	3.15	1.56	4.63	3.82	1.21
GRS-CQ14Pd/ NaB-M	7/6	14.00	3.18	4.40	12.00	3.38	3.55	11.70	4.50	2.60
	2/1	9.38	2.98	3.15	8.64	3.23	2.68	8.39	4.28	1.96
	-7/-8	7.96	2.93	2.71	6.83	3.15	2.17	6.45	4.06	1.59
	-15/-16	5.98	2.79	2.14	5.36	3.07	1.74	4.82	3.75	1.28
GRS-CQ16Pd/ NaB-M	7/6	16.00	3.90	4.10	14.50	4.03	3.60	13.60	5.23	2.60
	2/1	9.94	3.08	3.23	9.65	3.64	2.65	9.17	4.61	1.99
	-7/-8	8.24	3.34	2.47	8.13	3.36	2.42	7.24	4.45	1.63
	-15/-16	5.93	3.12	1.90	5.83	3.29	1.77	5.26	4.19	1.25

Note

1. During all the tests above, the water pump is disconnected to guarantee auxiliary heaters of indoor unit off;
2. During all the tests above, the water outlet and inlet temp were kept at 5°C (for example, Floor heating water outlet temp 35°C, then floor heating water inlet temp 30°C).

8 ELECTRICAL DATA

Model	Power Supply	Leakage Switch	Minimum Sectional Area of Earth Wire	Minimum Sectional Area of Power Supply Wire	
	V,Ph,Hz	(A)	(mm ²)	(mm ²)	
GRS-CQ6.0Pd/NaB-K(I)	220-240V,~,50Hz	32	4	3×4	
GRS-CQ8.0Pd/NaB-K(I)		50	10	3×10	
GRS-CQ10Pd/NaB-K(I)		50	10	3×10	
GRS-CQ12Pd/NaB-K(I)		50	10	3×10	
GRS-CQ14Pd/NaB-K(I)		50	10	3×10	
GRS-CQ16Pd/NaB-K(I)		50	10	3×10	
GRS-CQ6.0Pd/NaB-K(O)		32	4	3×4	
GRS-CQ8.0Pd/NaB-K(O)		32	4	3×4	
GRS-CQ10Pd/NaB-K(O)		32	4	3×4	
GRS-CQ12Pd/NaB-K(O)		32	4	3×4	
GRS-CQ14Pd/NaB-K(O)		32	4	3×4	
GRS-CQ16Pd/NaB-K(O)		32	4	3×4	
GRS-CQ12Pd/NaB-M(I)		380-415V,3N~,50Hz	16	1.5	5×1.5
GRS-CQ14Pd/NaB-M(I)			16	1.5	5×1.5
GRS-CQ16Pd/NaB-M(I)	16		1.5	5×1.5	
GRS-CQ12Pd/NaB-M(O)	25		2.5	5×2.5	
GRS-CQ14Pd/NaB-M(O)	25		2.5	5×2.5	
GRS-CQ16Pd/NaB-M(O)	25		2.5	5×2.5	

Note

1. Leakage Switch is necessary for additional installation. If circuit breakers with leakage protection are in use, action response time must be less than 0.1 second, leakage circuit must be 30mA.
2. The above selected power cable diameters are determined based on assumption of distance from the distribution cabinet to the unit less than 75m. If cables are laid out in a distance of 75m to 150m, diameter of power cable must be increased to a further grade.
3. The power supply must be of rated voltage of the unit and special electrical line for air-conditioning.
4. All electrical installation shall be carried out by professional technicians in accordance with the local laws and regulations.
5. Ensure safe grounding and the grounding wire shall be connected with the special grounding equipment of the building and must be installed by professional technicians.
6. The specifications of the breaker and power cable listed in the table above are determined based on the maximum power (maximum amps) of the unit.
7. The specifications of the power cable listed in the table above are applied to the conduit-guarded multi-wire copper cable (like, YJV XLPE insulated power cable) used at 40°C and resistible to 90°C(see IEC 60364-5-52). If the working condition changes, they should be modified according to the related national standard.
8. The specifications of the breaker listed in the table above are applied to the breaker with the working temperature at 40°C. If the working condition changes, they should be modified according to the related national standard.

9 FIELD WIRING DIAGRAM

GRS-CQ6.0Pd/NaB-K, GRS-CQ8.0Pd/NaB-K, GRS-CQ10Pd/NaB-K, GRS-CQ12Pd/NaB-K, GRS-CQ14Pd/NaB-K, GRS-CQ16Pd/NaB-K:

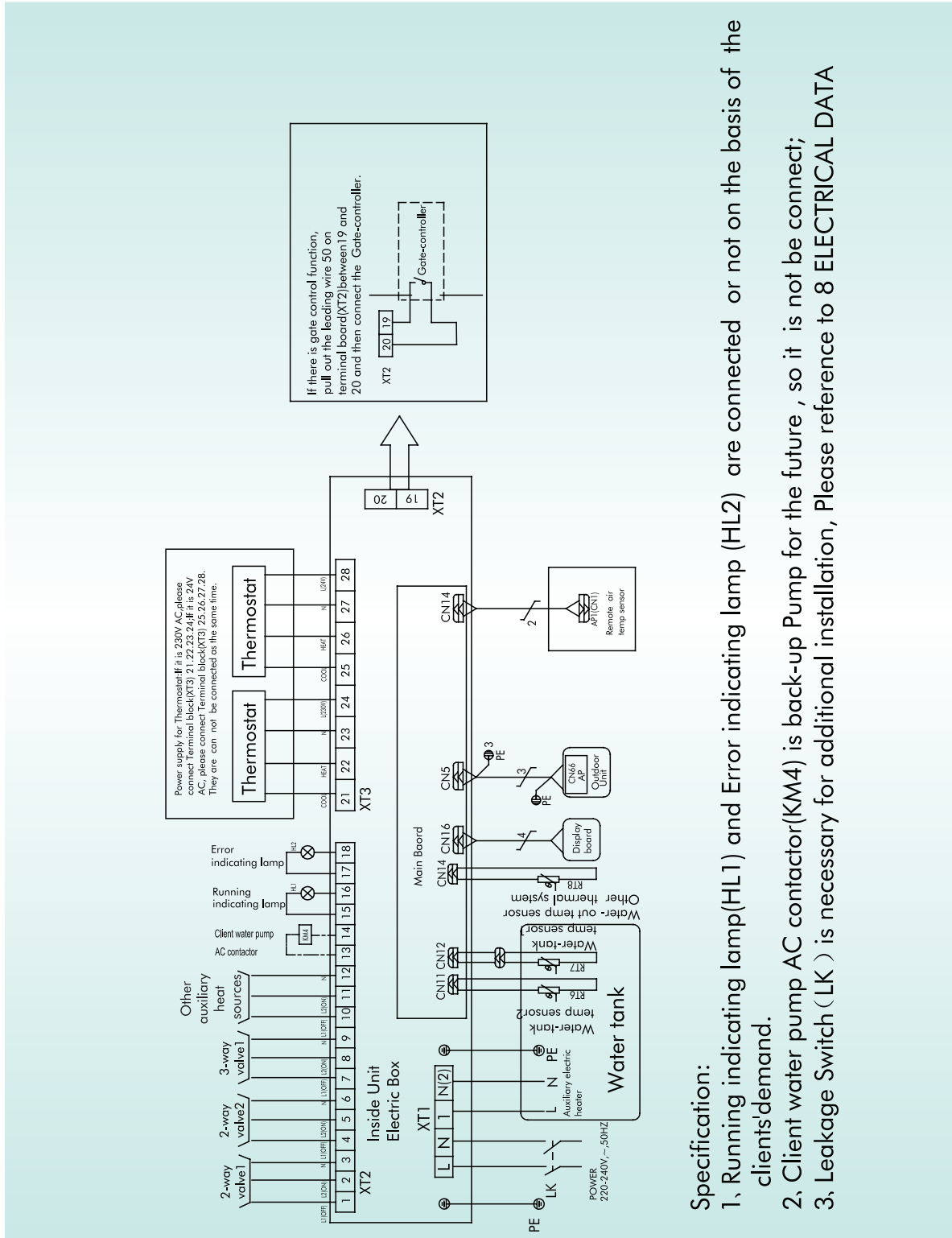

- Specification:**
- 1, Running indicating lamp(HL1) and Error indicating lamp (HL2) are connected or not on the basis of the clients'demand.
 - 2, Client water pump AC contactor(KM4) is back-up Pump for the future , so it is not be connect;
 - 3, Leakage Switch (LK) is necessary for additional installation, Please reference to 8 ELECTRICAL DATA

GRS-CQ12Pd/NaB-M, GRS-CQ14Pd/NaB-M, GRS-CQ16Pd/NaB-M:

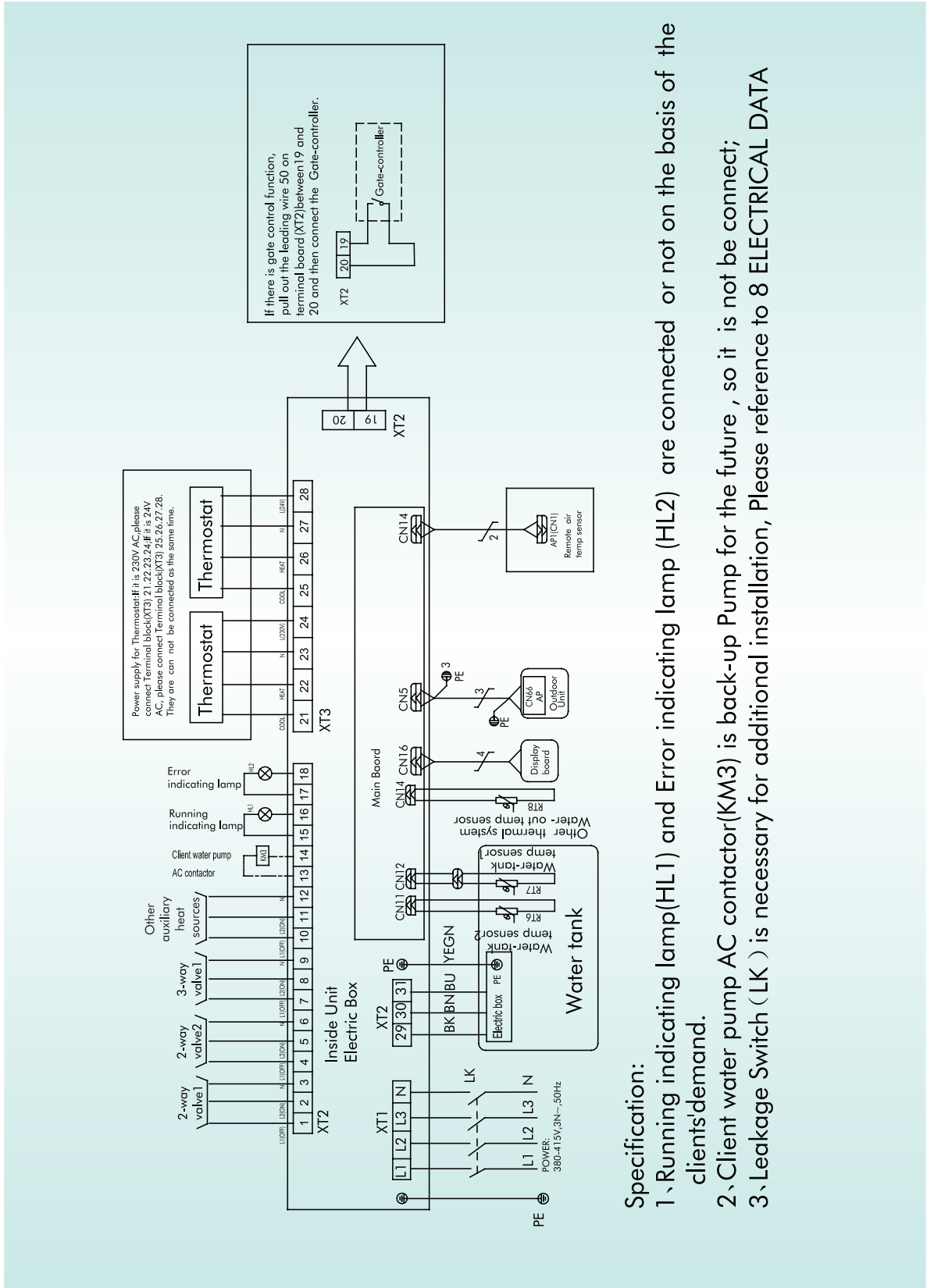

Specification:

1. Running indicating lamp(HL1) and Error indicating lamp (HL2) are connected or not on the basis of the clients'demand.
2. Client water pump AC contactor(KM3) is back-up Pump for the future , so it is not be connect;
3. Leakage Switch (LK) is necessary for additional installation, Please reference to 8 ELECTRICAL DATA

10 INSTALLATION

➔ 10.1 Installation of Outdoor Unit

Select Installation Location of Outdoor Unit

Outdoor unit must be installed on a firm and solid support.

Outdoor unit shall be installed close to the indoor unit, so as to minimize the length and bends of cooling pipe.

Avoid placing the outdoor unit under window or between two constructions, so as to prevent normal operating noise from entering the room.

Air inlet and outlet shall not be blocked.

Install at a well-ventilated place, so that the machine can absorb and discharge sufficient air.

Do not install at a place where flammable or explosive goods exist or a place subject to severe dust, salty fog and polluted air.

Outline dimension of outdoor unit

GRS-CQ6.0Pd/NaB-K(O), GRS-CQ8.0Pd/NaB-K(O), GRS-CQ10Pd/NaB-K(O):

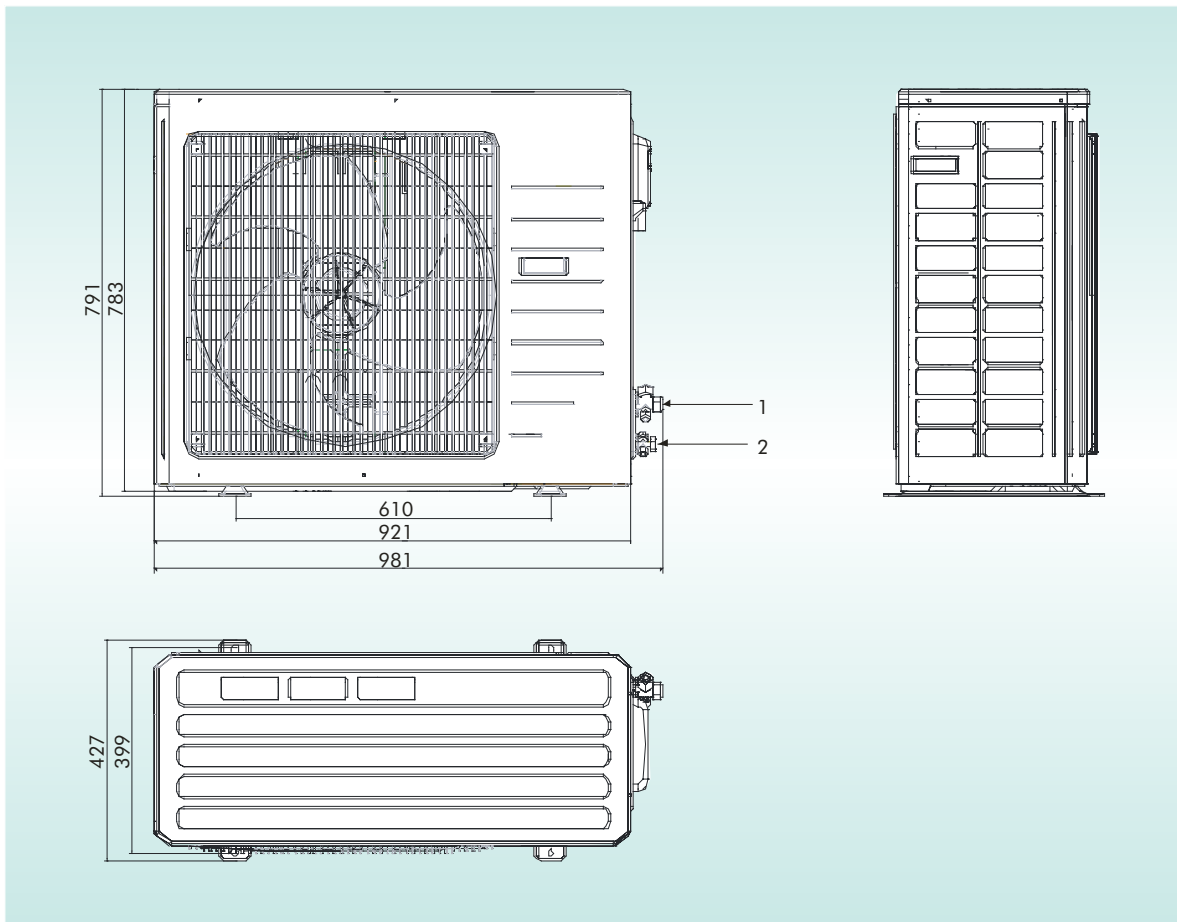

GRS-CQ12Pd/NaB-K(O), GRS-CQ14Pd/NaB-K(O), GRS-CQ16Pd/NaB-K(O), GRS-CQ12Pd/NaB-M(O), GRS-CQ14Pd/NaB-M(O), GRS-CQ16Pd/NaB-M(O):

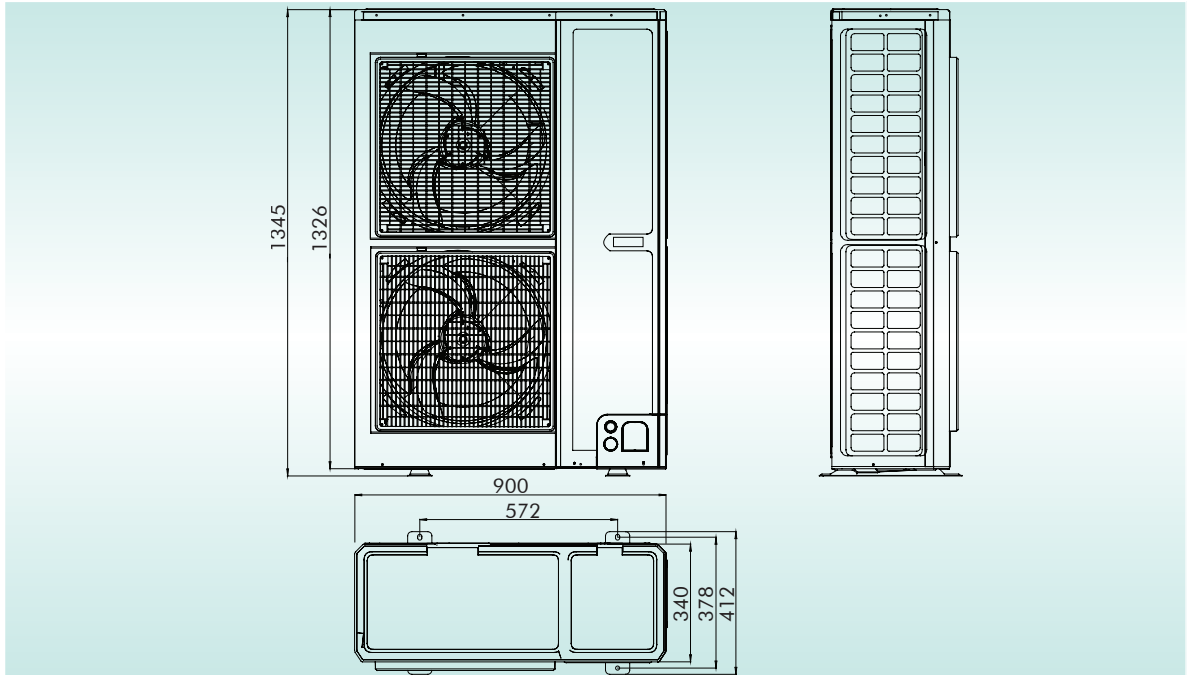

Pipe connection

Unit: inch

No	Name	Remarks	
1	Liquid-side Service Valve	3/8	GRS-CQ8.0/10/12/14/16Pd/NaB-K GRS-CQ12/14/16Pd/NaB-M
		1/4	GRS-CQ6.0Pd/NaB-K
2	Gas-side Service Valve	5/8	GRS-CQ8.0/10/12/14/16Pd/NaB-K GRS-CQ12/14/16Pd/NaB-M
		1/2	GRS-CQ6.0Pd/NaB-K

Space Requirements for Installation

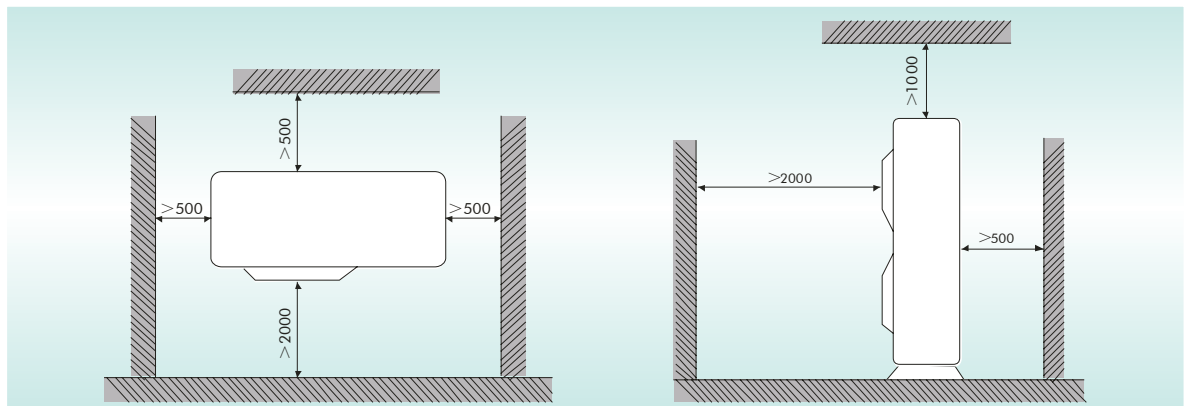

Installation Precautions of Outdoor Unit

When moving the outdoor unit, it is necessary to adopt 2 pieces of long enough rope to carry the unit from 4 directions. Included angle between the rope when hanging and moving must be 40° below to prevent center of the unit from shifting.

Adopt M12 bolts subassembly to tighten the feet and under the frame when installing.

Outdoor unit should be installed on concrete base that is 10cm high.

Requirements on installation space dimension of unit are shown in following drawing.

Outdoor unit must be lifted by using designated lifting hole. Take care to protect the unit during lift. To avoid rusting, do not knock the metal parts.



10.2 Installation of Indoor Unit

Select Installation Location of Indoor Unit

Avoid direct sunshine.

Ensure the hanger rod, ceiling and building structure have sufficient strength to support the weight of the air conditioner.

Drainage pipe is easy to connect.

Indoor and outdoor connecting pipes are easy to go outdoors.

Do not install at a place where flammable or explosive goods exist or flammable or explosive gas might leak.

Do not install at a place where there is corrosive gas, severe dust, salty fog, smoke or heavy moisture.

Air inlet and outlet air is not blocked.

Note

The water pressure gage is installed in returning water line in the indoor unit. Please adjust the hydraulics system pressure according to next item:

1. If the pressure is less than 0.5 bar, please recharge the water immediately;
2. when recharging, the hydraulics system pressure should be not more than 2.5Bar.

Outline Dimension of Indoor Unit

GRS-CQ6.0Pd/NaB-K(I), GRS-CQ8.0Pd/NaB-K(I), GRS-CQ10Pd/NaB-K(I), GRS-CQ12Pd/NaB-K(I), GRS-CQ14Pd/NaB-K(I), GRS-CQ16Pd/NaB-K(I), GRS-CQ12Pd/NaB-M(I), GRS-CQ14Pd/NaB-M(I), GRS-CQ16Pd/NaB-M(I):

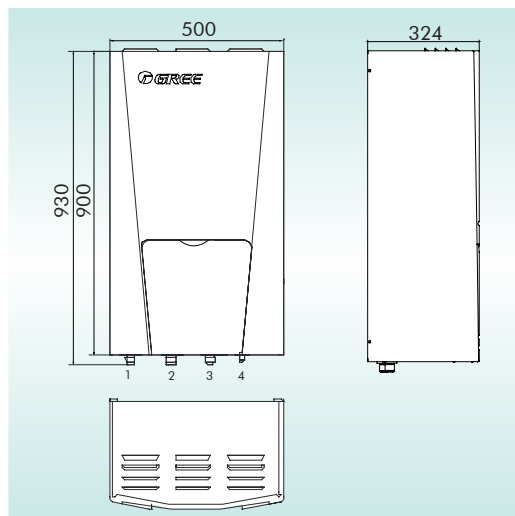

Pipe connection

Unit: inch

No	Name	Remarks
1	Water Outlet Pipe	1 " Male BSP
2	Water Inlet Pipe	1 " Male BSP
3	Liquid-side Service Valve	3/8 GRS-CQ8.0/10/12/14/16Pd/NaB-K
		GRS-CQ12/14/16Pd/NaB-M
	1/4 GRS-CQ6.0Pd/NaB-K	
4	Gas-side Service Valve	5/8 GRS-CQ8.0/10/12/14/16Pd/NaB-K
		GRS-CQ12/14/16Pd/NaB-M
		1/2 GRS-CQ6.0Pd/NaB-K

Space Requirements of Installation

GRS-CQ6.0Pd/NaB-K(I), GRS-CQ8.0Pd/NaB-K(I), GRS-CQ10Pd/NaB-K(I), GRS-CQ12Pd/NaB-K(I),GRS-CQ14Pd/NaB-K(I),GRS-CQ16Pd/NaB-K(I),GRS-CQ12Pd/NaB-M(I),GRS-CQ14Pd/NaB-M(I),GRS-CQ16Pd/NaB-M(I):

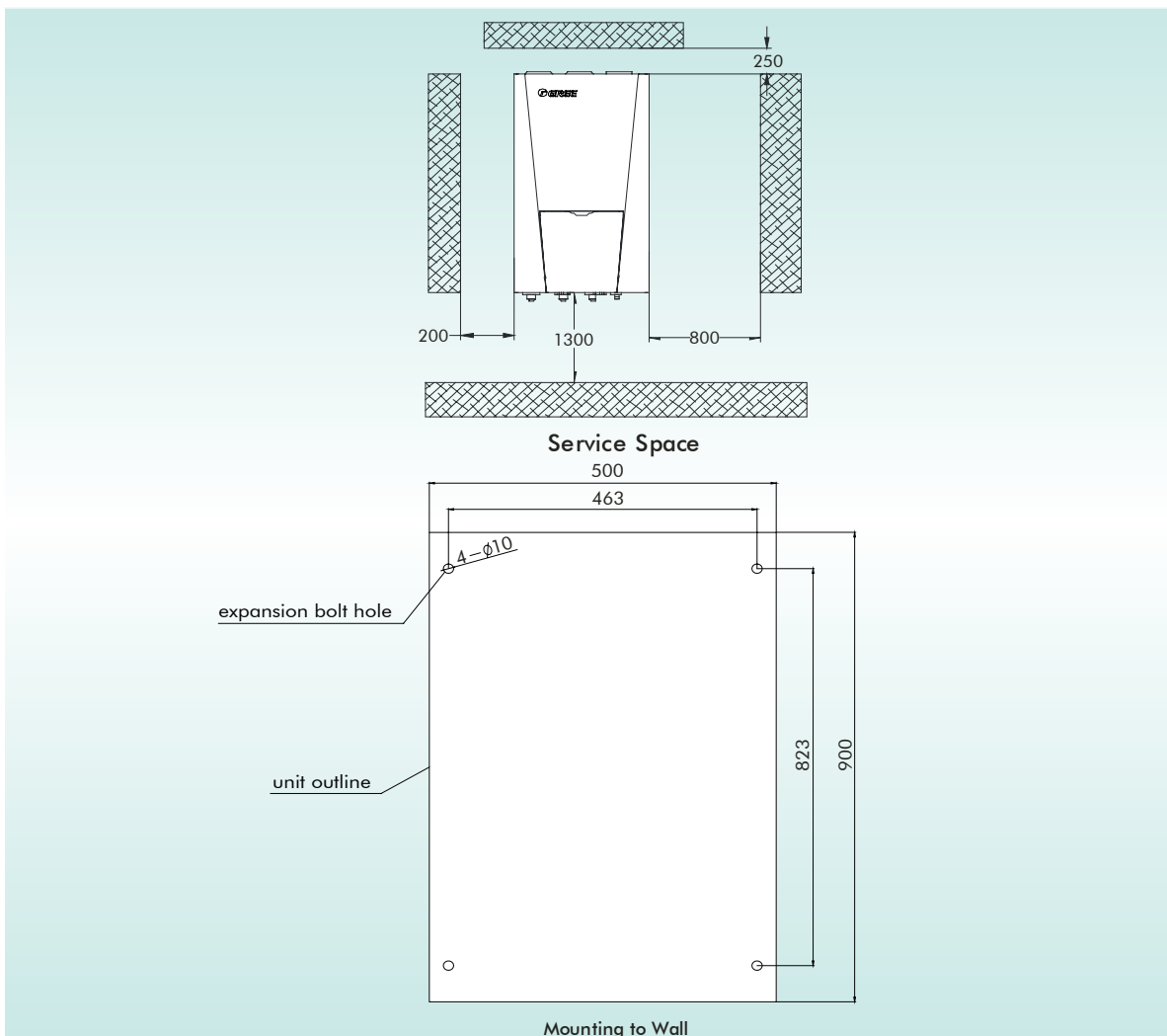

Indoor unit shall be vertically mounted on the wall of the room with expansion bolt.

Keep the indoor unit away from heat sources like heat sink and so on in the room as much as possible.

Keep the indoor unit as close as possible to outdoor unit. Level distance between connection pipes can not exceed 30m(8.0~16kW) or 20m(6.0kW) and vertical distance can not exceed 15m(8.0~16kW) or 10m(6.0kW).

➔ 10.3 Installation of Insulated Water Tank

Installation Measure

The insulated water tank should be installed and kept levelly within 5m and vertically within 3m from the indoor unit. It can be installed in the room.

Standing water tank must be installed vertically with the bottom on the ground, never suspended. Installation place must be firm enough and the water tank should be fixed on the wall with bolts to avoid vibration, as shown in the following figure. Weight capacity of water tank during installation should also be considered.

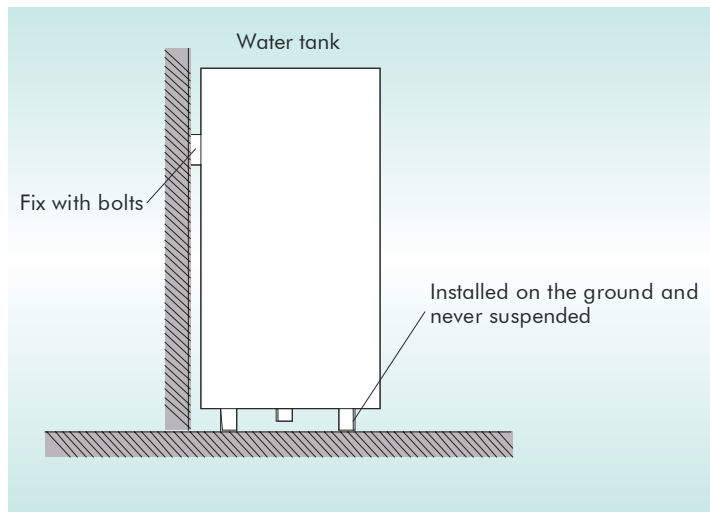

The minimum clearance from the water tank to combustible surface must be 500mm.

There should be water pipe, hot water joint and floor drain near the water tank in favor of water replenishment, hot water supply and drainage of water tank.

Connection of inlet/outlet waterway: Connect the safety check valve attached with the unit (→ points at insulated water tank) with the water inlet of water tank with PPR pipe according to the following figure, sealing with unsintered tape. The other end of the safety check valve should connect with tap water joint. Connect the hot water pipe and water outlet of water tank with PPR pipe.

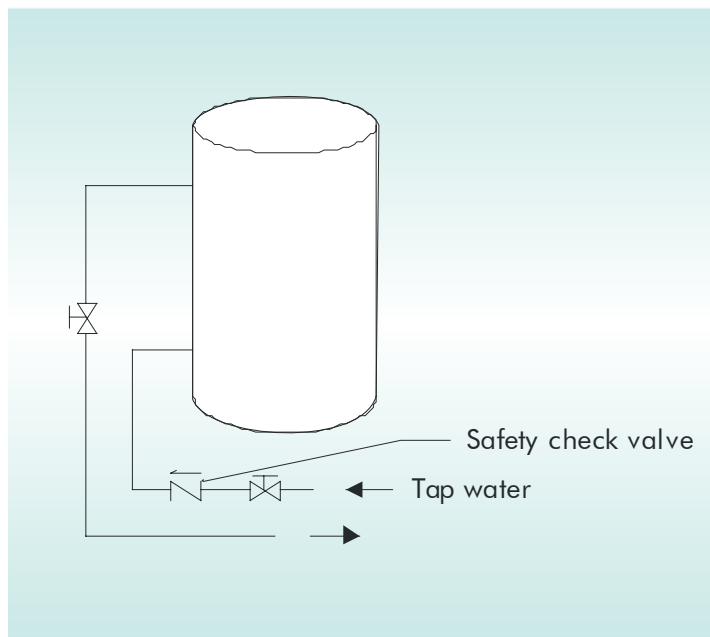

Note

For safe use of water, water outlet/inlet of water tank must connect with a certain length of PPR pipe, $L \geq 70 \times R^2$ (cm, R is inside radius of the pipe). Moreover, heat preservation should be conducted and metal pipe can not be used. For the first use, water tank must be full of water before the power is on.

Connection of Waterway System

If connection between water tank and indoor unit should be through the wall, drill a hole 70 for pass of circulating water pipe. It is unnecessary if the hole is not needed.

Preparation of pipelines: Circulating water outlet/inlet pipe must be hot water pipe, PPR pipe with nominal outer diameter of dn25. S2.5 series (wall thickness of 4.2mm) is recommended. Cooling water inlet pipe and hot water outlet pipe of water tank should also be hot water pipe, PPR pipe with nominal outer diameter of dn20. S2.5 series (wall thickness of 3.4mm) is recommended. If other insulated pipes are adopted, refer to the above dimensions for outer diameter and wall thickness.

Installation of circulating water inlet/outlet pipes: Connect the water inlet of unit with circulating outlet of water tank and water outlet of unit with circulating inlet of water tank.

Installation of circulating water inlet/outlet pipes: Connect the water inlet of unit with circulating outlet of water tank and water outlet of unit with circulating inlet of water tank.

Installation of water inlet/outlet pipes of water tank: Safety check valve (on the valve body points at water tank), filter and cut-off valve must be installed for water inlet pipe according to the installation sketch of unit. At least a cut-off valve is needed for the water outlet pipe.

Installation of blow-off pipe at the bottom of water tank: Connect a piece of PPR pipe with drainage outlet to floor drain. A cut-off valve must be installed in the middle of the drainage pipe and at the place where it is easy to be operated by the users.

After connection of all waterway pipelines, perform leakage test firstly (refer to debugging of the unit). After that, bind up the water pipes, water temp sensor and wires with wrapping tapes attached with the unit.

Refer to Installation Sketch of Unit for details.

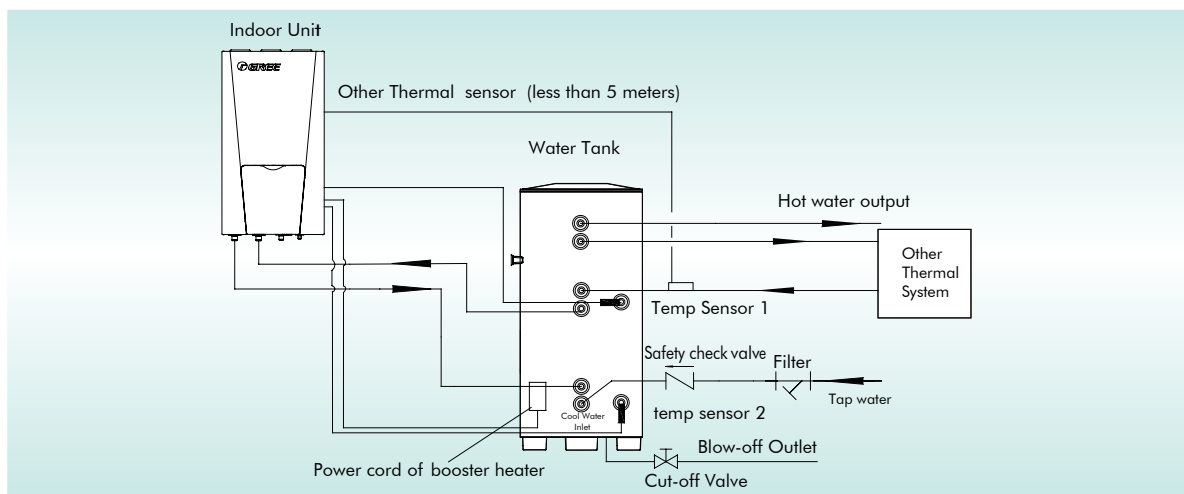

Joints Dimension	
Description	Joint pipe thread (inch)
Circulating water inlet/outlet of main unit	1" Male BSP
Cooling water inlet of water tank	1/2" Female BSP
Circulating water inlet/outlet of water tank	3/4" Female BSP
Hot water outlet of water tank	1/2" Female BSP

Note

Distance between main unit and insulated water tank should not exceed 5m levelly and 3m vertically. If higher, please contact with us. Water tank on lower and main unit on higher side is recommended.

Prepare the materials according to the above joints dimension. If cut-off valve is installed outside the room, PPR pipe is recommended to avoid freeze damage.

Waterway pipelines can't be installed until water heater unit is fixed. Do not let dust and other sundries enter into pipeline system during installation of connection pipes.

After connection of all waterway pipelines, perform leakage test firstly. After that, perform heat preservation of waterway system; meanwhile, pay more attention to valves and pipe joints. Ensure enough thickness of insulated cotton. If necessary, install heating device for pipeline to prevent the pipeline from freezing.

Hot water supplied from insulated water tank depends on pressure of water tap, so there must be supply of tap water.

During using, the cut-off valve of cooling water inlet of water tank should be kept normally on.

11 ACCESSORIES

Name	Standard	Optional	Field Supplied
Owner's Manual	√		
Control Panel Manual	√		
2-way Valve			√
3-way Valve			√
Remote Temperature Sensor	√		
Wired Controller	√		
Communication Cable	√		
Water Tank Temp. Sensor	√		
Expansion Bolt	√		
Water Pressure Gauge	√		

Gree Electric Appliances, Inc. of Zhuhai, founded in 1991, is the world's largest air conditioner enterprise integrating R&D, manufacturing, marketing and services. Technology Innovation and quality are always our priority. With efforts of thousands of Gree's engineers, we own more than 3500 patents for our products. Nowadays, we have 7 production bases in Zhuhai, Chongqing, Hefei and Zhengzhou(China), as well as Brazil, Pakistan and Vietnam, with annual production capacity of 30 million sets of residential air conditioners and 4 million sets of commercial air conditioners.

With the installation of Gree commercial air conditioners in important projects at home and abroad like Media Village for 2008 Beijing Olympic Games, Stadiums for 2010 World Cup in South Africa, as well as India Telecom base station, Gree commercial air conditioners are ready to develop steadily to every corner in the world, to present a more comfortable and harmonious working environment and family atmosphere.



Add: West Jinji Rd, Qianshan Zhuhai, Guangdong, China 519070

Tel: (+86-756)8614883 Fax: (+86-756)8614998

Http://www.gree.com Email: gree@gree.com.cn

For continuous improvement in the products, Gree reserves the right to modify the product specification and appearance in this manual without notice and without incurring and obligations.

■ SJ00404099