

DC INVERTER U-MATCH AIR CONDITIONERS

(GC201311)

BETTER CONDITIONERS GREE MAKING BETTER CONDITIONERS GREE MAKING BETTER CONDITIONERS GREE MAKING BETTER CONDITIONERS GREE MAKING BETTER CONDITIONERS

TECHNICAL SALES GUIDE-50Hz
CAPACITY RANGE:5~17kW
SUPER HIGH AMBIENT OPERATION TO 43°C



BETTER CONDITIONERS GREE MAKING BETTER CONDITIONERS GREE MAKING BETTER CONDITIONERS GREE MAKING BETTER CONDITIONERS GREE MAKING BETTER CONDITIONERS









GREE ELECTRIC APPLIANCES INC.OF ZHUHAI

CONTENTS

1. MODELS LIST.....	3
2. NOMENCLATURE	5
3. FUNCTION.....	7
4. PRODUCT DATA	13
5. FAN CHARACTERISTICS	88
6. DIMENSION	90
7. WIRING DIAGRAM.....	98
8. ACCESSORIES	102

1 MODELS LIST

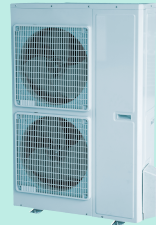
➔ 1.1 Outdoor Unit

Model	Power supply	Appearance
	(V, Ph, Hz)	
GUHD09NK3FO	220-240V~ 50Hz	
GUHD12NK3FO	220-240V~ 50Hz	
GUHD18NK3FO	220-240V~ 50Hz	
GUHD24NK3FO	220-240V~ 50Hz	
GUHD30NK3FO	220-240 V~ 50Hz	
GUHD36NK3FO	220-240V~ 50Hz	
GUHD36NM3FO	380-415V 3N~50Hz	
GUHD42NK3FO/GUHD48NK3FO	220-240V~ 50Hz	
GUHD42NM3FO/GUHD48NM3FO	380-415V 3N~ 50Hz	
GUHD60NM3FO	380-415V 3N~ 50Hz	

R410A

Note: 1 Ton = 12000Btu/h = 3.517kW

➔ 1.2 Indoor Unit

Duct Type:

Type	Model Name	Nominal Capacity Cooling/Heating (Btu/h)	Power supply (V, Ph, Hz)	Appearance	
Duct Type	R410A	GFH09K3FI	9212/9895	220-240V~ 50Hz	
		GFH12K3FI	11942/12966		
		GFH18K3FI	17060/19107		
		GFH24K3FI	23884/27296		
		GFH30K3FI	28320/31390		
		GFH36K3FI	34120/40944		
		GFH42K3FI	39238/46062		
		GFH48K3FI	47768/52886		
Cassette Type	R410A	GKH12K3FI	11942/12966	220-240V~ 50Hz	
		GKH18K3FI	17060/18766		
		GKH24K3FI	23884/27296		
		GKH30K3FI	28320/31390		
		GKH36K3FI	34120/40944		
		GKH42K3FI	37532/42650		
		GKH48K3FI	47768/54592		
Floor Ceiling Type	R410A	GTH09K3FI	9212/9895	220-240V~ 50Hz	
		GTH12K3FI	11942/12966		
		GTH18K3FI	17060/19107		
		GTH24K3FI	23884/27296		
		GTH30K3FI	29002/31390		
		GTH36K3FI	34120/40944		
		GTH42K3FI	39238/46062		
		GTH48K3FI	47768/54592		
GTH60K3FI	54592/58004				

Note: 1 Ton = 12000Btu/h = 3.517kW

Notes: The universal outdoor unit means that the customer can choose any of three kind of indoor unit to match the outdoor unit without any change with it.

2 NOMENCLATURE



2.1 Outdoor unit

G U H D 09 N K 3 F O
1 2 3 4 5 6 7 8 9 10

NO.	Description	Options
1	Gree Electric Appliances Inc	Capital Letter :G
2	Unit Type	U=Match Outdoor Unit
3	Product Type	C=Cool Only H=Heat Pump without Aux Electric Heaters
4	Compressor Power Supply Type Code	N=Constant Frequency D=DC Inverter A=AC Inverter
5	Nominal Cooling Capacity	Nominal Cooling Capacity =Number×1000Btu/h
6	Climate Type	N=Climate T1 Condition T= Climate T3 Condition
7	Power Supply Code	K=1Ph 220~240V 50HZ M=3Ph 380~415V 50HZ
8	Refrigerant	1 =R22 2=R407C 3=R410A
9	Design and design change Code	Design Code: A, B, C, D..... design change Code=0(Default) 1, 2, 3.....
10	Unit Code	O=Outdoor



2.2 Indoor unit

G F H 09 K 3 F I
1 2 3 4 5 6 7 8

NO.	Description	Options
1	Gree Electric Appliances Inc	Capital Letter :G
2	Unit Type	F=Duct Type K=Cassette Type T= Ceiling Type
3	Product Type	C=Cool Only H=Heat Pump without Aux Electric Heaters
4	Nominal Cooling Capacity	Nominal Cooling Capacity =Number×1000Btu/h
5	Climate Type	N=Climate T1 Condition T= Climate T3 Condition
6	Power Supply Code	K=220~240V~50Hz M=380-415V 3N~ 50Hz
7	Refrigerant	1 =R22 2=R407C 3=R410A
8	Design Code and design change Code	Design Code: A, B, C, D..... design change Code=0(Default) 1,2,3.....
9	Unit Code for Indoor Unit	I=Indoor Unit

3 FUNCTION

➔ 3.1 Description

Gree R410A AA DC Inverter U-Match Series Air Conditioners have combined the extraordinary comfort of the central air conditioners with the convenient installation and facility of the mini type of the split air conditioners. It is equipped with the condenser coil constructed of the hydrophilic aluminum sheet and the inner groove copper pipe, and also the low-noise compressor with various protections on the high/low pressure, high discharge temperature, overload, phase loss or reverse, and the sensor malfunction alarm. The casing of this unit is made of pre-painted steel, capable of resisting corrosion and rust creep and ensuring minimal fading when exposed to sunlight.

Gree R410A AA DC Inverter U-Match Series Air Conditioning Units can offer the perfect combination of superior product quality, high operating efficiency and cost efficiency. The capacity rated according to EN 14511 ranges from 09kBTu/h to 60 kBu/h, which could be sufficient to different requirements from customers. These units are CE certificated and manufactured under strict control with full conformance to ISO 9001:2000 and ISO 14001 standards. All units are factory tested prior to dispatch to verify the operation performance and control functioning.

Gree R410A AA DC Inverter U-Match Series Air Conditioning Units can be widely used in small supermarkets, chain stores, hotels, restaurants, offices and meeting room etc. especially fit for the small commercial and industrial application. Its indoor units come to cassette type, duct type and floor ceiling type, making the installation more flexible. The unit can set for cooling even when the outdoor ambient temperature drops to -15°C and thus an ideal for locations that require cooling even in winter.

The careful design from each part to the whole unit, together with the all-round process test and unit test, offers the high reliability for the whole system.

Perfect system protections can guarantee the safety of the system at utmost and get rid of the irreparable damage to the compressor or other critical parts under the harsh working conditions, including:

➔ 3.2 Features-Outdoor Units

Unit protections

High reliability

- The careful design from each part to the whole unit, together with the all-round process test and unit test, offers the high reliability for the whole system.

Long-term durability

- Perfect system protections can guarantee the safety of the system at utmost and get rid of the irreparable damage to the compressor or other critical parts under the harsh working conditions.

High/low pressure protection

- When suction pressure is too low or discharge pressure is too high, compressor will stop and unit display malfunction code.

Overload protection

- The compressor has its own overheat protection. Once the temperature of compressor is higher than allowable level, compressor will stop and only when temperature recovery, compressor restart.

Discharge high temperature protection

- Once the discharge temperature of compressor is higher than allowable value, compressor will stop and unit display malfunction code.

Anti-high temperature protection

- Once the heat exchanger temperature of indoor unit is too high ,the outdoor fan motor will stop.

Sensor malfunction alarming

- Once the sensor short out or shutdown, unit will display malfunction code.

Anti-freezing protection

- When it is detected that the temperature of the evaporator is too low, the compressor will stop to protection the whole system.

Over-current protection

- When it is detected that the running current of the compressor comes abnormal, the compressor will stop to protection the whole system.

Communication malfunction

- When the unit fails to perform the normal communication, it will stop to protect the whole system.

Special protections have been taken for the control of the inverter unit to prevent it from being damaged, including:

Unit protections

PFC or IPM module protection

- When the PFC or IPM module works abnormally, the unit will stop to protect the whole system.

DC busbar voltage protection

- When the voltage of the DC bus comes abnormal, the unit will stop to protect the compressor.

PFC or IPM temperature too high protection

- When the temperature of the PFC or the IPM module is too high, the unit will stop to protect the whole system.

Anti-high temperature protection

- once the heat exchanger temperature of indoor unit is too high, the outdoor fan motor will stop.

Compressor frequency control

- The final running frequency of the compressor is limited to the minimum value to realize the lowest energy consumption.

Change rate of the compressor

- the frequency change rate varies with the change of the load.

4-way valve control

- for the heat pump units, the unit is able to perform heating through the 4-way valve.

Automatic defrosting

- when the heat pump unit performs heating, the automatic defrosting will work in according to the frosting condition on the outdoor unit so as to protect the whole system.

Low-temperature cooling

- the unit is able to work reliably under the -15°C ambient environment through adjusting the running speed of the outdoor unit's fan.

Deicing

- Deicing: the electric heating tape on the chassis will perform heating to prevent the chassis icing which would affect the performance of the unit.

➔ 3.3 Features-Indoor Units

(1) Duct Type

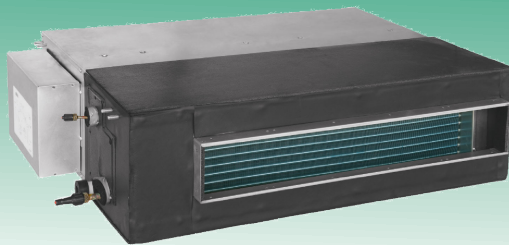

Airflow Patterns for Extra Comfort :

It can connect many supply-air outlets to the duct, so that it can make the temperature and humidity of the whole room even, meanwhile, it can lead in fresh air, makes good indoor unit air quality. All units are provided with filters that they are easily accessible from the rear of the unit.

Flexible Installation:

Air-supply or air-return type, condensation water exit direction, and modes of wye (adopting either underside air back or rear air back) etc can be selected flexibly.

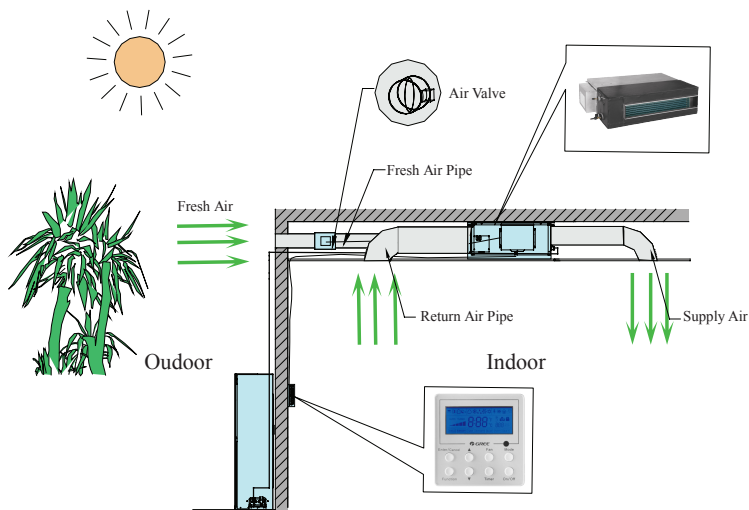

Easy Maintenance:

Evaporator coils are constructed of quality inner groove copper tube and hydrophilic aluminum sheet. It adopts easy and reliable configuration design ,so Maintenance is very convenient and easy.



Versatile Functions:

- ◆ Multi-Speeds fan control
- ◆ Comfortable cool and energy save function
- ◆ Vacation function
- ◆ Low temperature dry
- ◆ Long-distance monitoring
- ◆ Double wired controller control function
- ◆ Light board control:



(2) Floor Ceiling Type



Flexible Installation :

There are two styles of installation: Ceiling Type and floor Type.

Ceiling Type:



Floor Type:



Easier Maintenance and Cleaning :

The Ceiling Type is equipped with anti-mould long-life air filter .If the air filter is very dirty, can clean it by a vacuum cleaner or wash it with soap water.

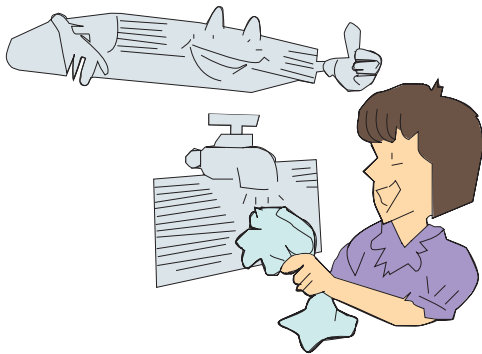

Versatile Functions:

- ◆ Multi-Speeds fan control
- ◆ Comfortable cool and energy save function
- ◆ Vacation function
- ◆ Low temperature dry
- ◆ Long-distance monitoring
- ◆ Double wired controller control function
- ◆ Indicating lamp display:

- POWER
- COOL
- HEAT

(3) Cassette Type



Airflow Patterns for Extra Comfort :

It can blow to four different directions, so that it can make the temperature and humidity of the whole room equality .

Low Noise :

It adopts low noise design, such as low noise fan, low noise motor, etc.

Easy Maintenance and Cleaning:

It adopts easy and reliable configuration design, so Maintenance is very convenient.

Airflow direction control

The louver can be set at the desired position or swing up and down automatically.

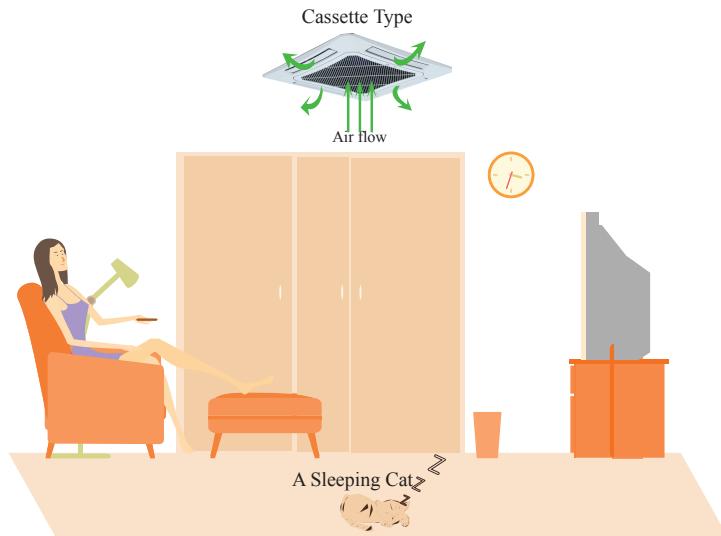

Versatile Functions:

- ◆ Multi-Speeds fan control
- ◆ Comfortable cool and energy save function
- ◆ Vacation function
- ◆ Low temperature dry
- ◆ Long-distance monitoring
- ◆ Double wired controller control function
- ◆ The panel display:



4 PRODUCT DATA

4.1 Product Data at Rated Condition

4.1.1 Duct Type

Model	Indoor unit		GFH09K3FI	GFH12K3FI
	Outdoor unit		GUHD09NK3FO	GUHD12NK3FO
Nominal Capacity	Cooling	kW	2.70	3.50
		Btu/h	9212	11942
	Heating	kW	2.90	3.80
		Btu/h	9895	12966
Power Input	Cooling	kW	0.84	1.17
	Heating	kW	0.80	1.05
EER/COP		W/W	3.21/3.61	3.00/3.61
Indoor Unit			GFH09K3FI	GFH12K3FI
Power Supply		–	220-240V~ 50Hz	
Heat Exchange		–	Cross Fin Coil	Cross Fin Coil
Fan	Type	–	Centrifugal fan	Centrifugal fan
	Drive	–	direct	direct
	Motor Output	kW	–	
	Air Flow	m ³ /h	650	750
	Rated Ext. Static Pressure	Pa	25	25
Sound Pressure Level(H/M/L)		dB(A)	34/28/26	36/34/28
Air Filter		–	PP	
Drain Piping		mm	ø20×1.2	ø30×1.5
Dimensions (W×H×D)	Outline	mm	925×250×665	1037×266×721
	Package	mm	1023×320×748	1123×323×798
Weight(Net/Gross)		kg	27/32	33/38
Outdoor Unit			GUHD09NK3FO	GUHD12NK3FO
Power Supply		–	220-240V~ 50Hz	
Heat Exchange		–	Cross Fin Coil	
Fan	Type	–	Axial-flow	
	Fan Motor Speed	rpm	860	860
Compressor	Type	–	Inverter Rotary	Inverter Rotary
	Power Input	W	942	942
Refrigerant	Type	–	R410A	
	Control	–	Electronic Expansion Valve	
	Charge	kg	1.2	1.2
Dimensions (W×H×D)	Outline	mm	848×540×320	848×540×320
	Package	mm	881×595×363	881×595×363
Weight(Net/Gross)		kg	34/37	34/37
Piping Connections	Liquid	Inch	ø1/4	ø1/4
	Gas	Inch	ø3/8	ø3/8
	Max. Length	m	20	20
	Max. Height	m	15	15

Model	Indoor unit		GFH18K3FI	GFH24K3FI	GFH30K3FI
	Outdoor unit		GUHD18NK3FO	GUHD24NK3FO	GUHD30NK3FO
Nominal Capacity	Cooling	kW	5.00	7.00	8.30
		Btu/h	17060	23884	28320
	Heating	kW	5.60	8.0	9.20
		Btu/h	19107	27296	31390
Power Input	Cooling	kW	1.55	2.18	2.67
	Heating	kW	1.55	2.21	2.57
EER/COP		W/W	3.23/3.61	3.21/3.62	3.11/3.58
Indoor Unit			GFH18K3FI	GFH24K3FI	GFH30K3FI
Power Supply		–	220-240V~ 50Hz		
Heat Exchange		–	Cross Fin Coil	Cross Fin Coil	Cross Fin Coil
Fan	Type	–	Centrifugal fan	Centrifugal fan	Centrifugal fan
	Drive	–	direct	direct	direct
	Motor Output	kW	–		
	Air Flow	m ³ /h	1000	1400	1400
	Rated Ext. Static Pressure	Pa	25	25	37
Sound Pressure Level(H/M/L)		dB(A)	39/36/28	46/44/40	46/44/40
Air Filter		–	PP	PPKZ	PPKZ
Drain Piping		mm	ø30×1.5	ø20×1.2	ø20×1.2
Dimensions (W×H×D)	Outline	mm	1037×266×721	1279×268×558	1279×268×558
	Package	mm	1123×323×798	1348×283×597	1348×283×597
Weight(Net/Gross)		kg	33/38	34/39	34/39
Outdoor Unit			GUHD18NK3FO	GUHD24NK3FO	GUHD30NK3FO
Power Supply		–	220-240V~ 50Hz		
Heat Exchange		–	Cross Fin Coil		
Fan	Type	–	Axial fan		
	Fan Motor Speed	rpm	840	840	840
Compressor	Type	–	Inverter Rotary	Inverter Rotary	Inverter Rotary
	Power Input	W	1440	2550	2550
Refrigerant	Type	–	R410A		
	Control	–	Electronic Expansion Valve		
	Charge	kg	1.4	2.2	2.4
Dimensions (W×H×D)	Outline	mm	955×700×396	980×790×427	980×790×427
	Package	mm	1029× 750×458	1083×855×488	1083×855×488
Weight(Net/Gross)		kg	47/50	67/72	71/76
Piping Connections	Liquid	Inch	ø1/4	ø3/8	ø3/8
	Gas	Inch	ø1/2	ø5/8	ø5/8
	Max. Length	m	20	30	30
	Max. Height	m	15	15	15

DC Inverter U-match Air Conditioners Technical Sales Guide

Model	Indoor unit		GFH36K3FI	GFH36K3FI	GFH42K3FI
	Outdoor unit		GUHD36NK3FO	GUHD36NM3FO	GUHD42NK3FO
Nominal Capacity	Cooling	kW	10.0	10.0	11.50
		Btu/h	34120	34120	39238
	Heating	kW	12.0	12.0	13.50
		Btu/h	40944	40944	46062
Power Input	Cooling	kW	3.20	3.12	4.00
	Heating	kW	3.40	3.32	3.90
EER/COP		W/W	3.12/3.53	3.21/3.61	2.88/3.46
Indoor Unit			GFH36K3FI	GFH36K3FI	GFH42K3FI
Power Supply		–	220-240V,~50Hz		
Heat Exchange		–	Cross Fin Coil		
Fan	Type	–	Centrifugal fan		
	Drive	–	direct		
	Motor Output	kW	–		
	Air Flow	m ³ /h	2100	2100	2100
	Rated Ext. Static Pressure	Pa	37	37	37
Sound Pressure Level(H/M/L)		dB(A)	52/48/44	52/48/44	52/48/44
Air Filter		–	PPKZ		
Drain Piping		mm	ø20×1.2	ø20×1.2	ø20×1.2
Dimensions (W×H×D)	Outline	mm	1226×290×775	1226×290×775	1226×290×775
	Package	mm	1338×305×877	1338×305×877	1338×305×877
Weight(Net/Gross)		kg	46/53	46/53	46/53
Outdoor Unit			GUHD36NK3FO	GUHD36NM3FO	GUHD42NK3FO
Power Supply		–	220-240V~ 50Hz	380-415V 3N~ 50Hz	220-240V~ 50Hz
Heat Exchange		–	Cross Fin Coil	Cross Fin Coil	Cross Fin Coil
Fan	Type	–	Axial fan	Axial fan	Axial fan
	Fan Motor Speed	rpm	900	900	820
Compressor	Type	–	Inverter Rotary	Inverter Rotary	Inverter Rotary
	Power Input	W	4150	4000	4150
Refrigerant	Type	–	R410A	R410A	R410A
	Control	–	Electronic Expansion Valve		
	Charge	kg	3.5	3.5	3.7
Dimensions (W×H×D)	Outline	mm	1107×1100×440	1107×1100×440	958×1349×412
	Package	mm	1158×1235×493	1158×1235×493	1043×1500×453
Weight(Net/Gross)		kg	92/100	98/106	95/105
Piping Connections	Liquid	Inch	ø3/8	ø3/8	ø3/8
	Gas	Inch	ø5/8	ø5/8	ø5/8
	Max. Length	m	30	30	50
	Max. Height	m	15	15	30

Model	Indoor unit		GFH42K3FI	GFH48K3FI	GFH48K3FI
	Outdoor unit		GUHD42NM3FO	GUHD48NK3FO	GUHD48NM3FO
Nominal Capacity	Cooling	kW	11.5	14	14
		Btu/h	39238	47768	47768
	Heating	kW	13.5	15.5	15.5
		Btu/h	46062	52886	52886
Power Input	Cooling	kW	4.00	4.7	5.1
	Heating	kW	3.90	4.4	4.5
EER/COP		W/W	2.88/3.46	2.98/3.52	2.75/3.44
Indoor Unit			GFH42K3FI	GFH48K3FI	GFH48K3FI
Power Supply		-	220-240V~ 50Hz		
Heat Exchange		-	Cross Fin Coil		
Fan	Type	-	Centrifugal fan		
	Drive	-	direct		
	Motor Output	kW	-		
	Air Flow	m ³ /h	2100	2400	2400
	Rated Ext. Static Pressure	Pa	37	50	50
Sound Pressure Level(H/M/L)		dB(A)	52/48/44	53/49/45	53/49/45
Air Filter		-	PPKZ		
Drain Piping		mm	ø20×1.2	ø20×1.2	ø20×1.2
Dimensions (W×H×D)	Outline	mm	1226×290×775	1340×350×750	1340×350×750
	Package	mm	1338×305×877	1423×455×837	1423×455×837
Weight(Net/Gross)		kg	46/53	56/65	56/65
Outdoor Unit			GUHD42NM3FO	GUHD48NK3FO	GUHD48NM3FO
Power Supply		-	380-415V 3N~ 50Hz	220-240V~ 50Hz	380-415V 3N~ 50Hz
Heat Exchange		-	Cross Fin Coil		
Fan	Type	-	Axial fan		
	Fan Motor Speed	rpm	820	820	820
Compressor	Type	-	ROTARY		
	Power Input	W	4000	4580	4580
Refrigerant	Type	-	R410A		
	Control	-	Electronic Expansion Valve		
	Charge	kg	3.7	4.0	4.0
Dimensions (W×H×D)	Outline	mm	958×1349×412	958×1349×412	958×1349×412
	Package	mm	1043×1500×453	1043×1500×453	1043×1500×453
Weight(Net/Gross)		kg	108/118	105/115	114/124
Piping Connections	Liquid	Inch	ø3/8	ø3/8	ø3/8
	Gas	Inch	ø5/8	ø5/8	ø5/8
	Max. Length	m	50	50	50
	Max. Height	m	30	30	30

DC Inverter U-match Air Conditioners Technical Sales Guide

Model	Indoor unit		GFH60K3FI
	Outdoor unit		GUHD60NM3FO
Nominal Capacity	Cooling	kW	16
		Btu/h	54592
	Heating	kW	16.5
		Btu/h	56298
Power Input	Cooling	kW	5.6
	Heating	kW	4.57
EER/COP		W/W	2.86/3.61
Indoor Unit			GFH60K3FI
Power Supply		–	220-240V~ 50Hz
Heat Exchange		–	Cross Fin Coil
Fan	Type	–	Centrifugal fan
	Drive	–	direct
	Motor Output	kW	–
	Air Flow	m ³ /h	3000
	Rated Ext. Static Pressure	Pa	50
Sound Pressure Level(H/M/L)		dB(A)	56/54/49
Air Filter		–	PPKZ
Drain Piping		mm	ø20×1.2
Dimensions (W×H×D)	Outline	mm	1340×350×750
	Package	mm	1423×455×837
Weight(Net/Gross)		kg	57/69
Outdoor Unit			GUHD60NM3FO
Power Supply		–	380-415V 3N~ 50Hz
Heat Exchange		–	Cross Fin Coil
Fan	Type	–	Axial fan
	Fan Motor Speed	rpm	820
Compressor	Type	–	ROTARY
	Power Input	W	4580
Refrigerant	Type	–	R410A
	Control	–	Electronic Expansion Valve
	Charge	kg	5
Dimensions (W×H×D)	Outline	mm	1085×1365×427
	Package	mm	1143×1505×478
Weight(Net/Gross)		kg	126/138
Piping Connections	Liquid	inch	ø3/8
	Gas	inch	ø3/4
	Max. Length	m	50
	Max. Height	m	30

DC Inverter U-match Air Conditioners Technical Sales Guide

Model	Indoor unit		GKH30K3FI	GKH36K3FI	GKH36K3FI
	Outdoor unit		GUHD30NK3FO	GUHD36NK3FO	GUHD36NM3FO
Nominal Capacity	Cooling	kW	8.3	10	10
		Btu/h	28320	34120	34120
	Heating	kW	9.2	12.0	12
		Btu/h	31390	40944	40944
Power Input	Cooling	kW	2.67	3.2	3.12
	Heating	kW	2.57	3.5	3.32
EER/COP		W/W	3.11/3.58	3.13/3.43	3.21/3.61
Indoor Unit			GKH30K3FI	GKH36K3FI	GKH36K3FI
Power Supply		–	220-240V~ 50Hz		
Heat Exchange		–	Cross Fin Coil		
Fan	Type	–	Centrifugal fan		
	Drive	–	direct	direct	direct
	Motor Output	kW	–		
	Air Flow	m ³ /h	1500	1860	1860
Sound Pressure Level(H/M/L)		dB(A)	48/45/40	49/46/43	49/46/43
Air Filter		–	Standard washable synthetic		
Drain Piping		mm	ø25×1.5	ø25×1.5	ø25×1.5
Indoor Unit Dimensions (W×H×D)	Outline	mm	840×320×840	840×320×840	840×320×840
	Package	mm	963×409×963	963×409×963	963×409×963
Weight(Net/Gross)		kg	31/38	31/38	31/38
Panel Dimensions (W×H×D)	Outline	mm	950×60×950	950×60×950	950×60×950
	Package	mm	1028×130×1043	1028×130×1043	1028×130×1043
Panel Weight(Net/Gross)		kg	7/11	7/11	7/11
Outdoor Unit			GUHD30NK3FO	GUHD36NK3FO	GUHD36NM3FO
Power Supply		–	220-240V~ 50Hz	220-240V~ 50Hz	380-415V 3N~ 50Hz
Heat Exchange		–	Cross Fin Coil		
Fan	Type	–	Axial fan		
	Fan Motor Speed	rpm	840	900	
Compressor	Type	–	ROTARY		
	Power Input	W	2550	4150	4000
Refrigerant	Type	–	R410A		
	Control	–	Electronic Expansion Valve		
	Charge	kg	2.4	3.5	3.5
Dimensions (W×H×D)	Outline	mm	980×790×427	1107×1100×440	1107×1100×440
	Package		1083×855×488	1158×1235×493	1158×1235×493
Weight(Net/Gross)		kg	71/76	92/100	98/106
Piping Connections	Liquid	Inch	ø3/8	ø3/8	ø3/8
	Gas	Inch	ø5/8	ø5/8	ø5/8
	Max. Length	m	30	30	30
	Max. Height	m	15	15	15

Model	Indoor unit		GKH42K3FI	GKH42K3FI
	Outdoor unit		GUHD42NK3FO	GUHD42NM3FO
Nominal Capacity	Cooling	kW	11	11
		Btu/h	37532	37532
	Heating	kW	12.5	12.5
		Btu/h	42650	42650
Power Input	Cooling	kW	3.9	3.9
	Heating	kW	3.8	3.8
EER/COP		W/W	2.82/3.29	2.82/3.29
Indoor Unit			GKH42K3FI	GKH42K3FI
Power Supply		–	220-240V~ 50Hz	
Heat Exchange		–	Cross Fin Coil	Cross Fin Coil
Fan	Type	–	Centrifugal fan	Centrifugal fan
	Drive	–	direct	direct
	Motor Output	kW	–	
	Air Flow	m ³ /h	1860	1860
Sound Pressure Level(H/M/L)		dB(A)	49/46/43	49/46/43
Air Filter		–	ABS+PP	
Drain Piping		mm	ø25×1.5	ø25×1.5
Indoor Unit Dimensions (W×H×D)	Outline	mm	840×320×840	840×320×840
	Package	mm	963×409×963	963×409×963
Weight(Net/Gross)		kg	31/38	31/38
Panel Dimensions (W×H×D)	Outline	mm	950×60×950	950×60×950
	Package	mm	1028×130×1043	1028×130×1043
Panel Weight(Net/Gross)		kg	7/11	7/11
Outdoor Unit			GUHD42NK3FO	GUHD42NM3FO
Power Supply		–	220-240V~ 50Hz	380-415V 3N~ 50Hz
Heat Exchange		–	Cross Fin Coil	Cross Fin Coil
Fan	Type	–	Axial fan	Axial fan
	Fan Motor Speed	rpm	820	820
Compressor	Type	–	ROTARY	ROTARY
	Power Input	W	4150	4000
Refrigerant	Type	–	R410A	R410A
	Control	–	Electronic Expansion Valve	
	Charge	kg	3.7	3.7
Dimensions (W×H×D)	Outline	mm	958×1349×412	958×1349×412
	Package	mm	1043×1500×453	1043×1500×453
Weight(Net/Gross)		kg	95/105	108/118
Piping Connections	Liquid	Inch	ø3/8	ø3/8
	Gas	Inch	ø5/8	ø5/8
	Max. Length	m	50	50
	Max. Height	m	30	30

DC Inverter U-match Air Conditioners Technical Sales Guide

Model	Indoor unit		GKH48K3FI	GKH48K3FI	GKH60K3FI
	Outdoor unit		GUHD48NK3FO	GUHD48NM3FO	GUHD60NM3FO
Nominal Capacity	Cooling	kW	14	14	16
		Btu/h	47768	47768	54592
	Heating	kW	16	16	17
		Btu/h	54592	54592	58004
Power Input	Cooling	kW	4.6	5.15	5.7
	Heating	kW	4.5	4.5	4.7
EER/COP		W/W	3.04/3.56	2.72/3.56	2.81/3.61
Indoor Unit			GKH48K3FI	GKH48K3FI	GKH60K3FI
Power Supply		–	220-240V~ 50Hz		
Heat Exchange		–	Cross Fin Coil		
Fan	Type	–	Centrifugal fan		
	Drive	–	direct	direct	direct
	Motor Output	kW	–		
	Air Flow	m ³ /h	2300	2300	2400
Sound Pressure Level(H/M/L)		dB(A)	52/47/41	52/47/41	53/47/41
Air Filter		–	ABS+PP		
Drain Piping		mm	ø25×1.5	ø25×1.5	ø25×1.5
Indoor Unit Dimensions (W×H×D)	Outline	mm	910×290×910	910×290×910	910×290×910
	Package	mm	1023×375×993	1023×375×993	1023×375×993
Weight(Net/Gross)		kg	43/50	43/50	43/50
Panel Dimensions (W×H×D)	Outline	mm	1040×65×1040	1040×65×1040	1040×65×1040
	Package	mm	1137×140×1137	1137×140×1137	1137×140×1137
Panel Weight(Net/Gross)		kg	8/12	8/12	8/12
Outdoor Unit			GUHD48NK3FO	GUHD48NM3FO	GUHD60NM3FO
Power Supply		–	220-240V~ 50Hz	380-415V 3N~50Hz	380-415V 3N~50Hz
Heat Exchange		–	Cross Fin Coil		
Fan	Type	–	Axial fan		
	Fan Motor Speed	rpm	820	820	820
Compressor	Type	–	ROTARY	ROTARY	
	Power Input	W	4580	4580	
Refrigerant	Type	–	R410A		
	Control	–	Electronic Expansion Valve		
	Charge	kg	4.0	4.0	5.0
Dimensions (W×H×D)	Outline	mm	958×1349×412	958×1349×412	1085×1365×427
	Package	mm	1043×1500×453	1043×1500×453	1143×1505×478
Weight(Net/Gross)		kg	105/115	114/124	126/138
Piping Connections	Liquid	Inch	ø3/8	ø3/8	ø3/8
	Gas	Inch	ø5/8	ø5/8	ø3/4
	Max. Length	m	50	50	50
	Max. Height	m	30	30	30

4.1.3 Ceiling Type

Model	Indoor unit		GTH09K3FI	GTH12K3FI
	Outdoor unit		GUHD09NK3FO	GUHD12NK3FO
Nominal Capacity	Cooling	kW	2.7	3.5
		Btu/h	9212	11942
	Heating	kW	2.9	3.8
		Btu/h	9895	12966
Power Input	Cooling	kW	0.84	1.09
	Heating	kW	0.80	1.05
EER/COP		W/W	3.21/3.61	3.21/3.61
Indoor Unit			GTH09K3FI	GTH12K3CI
Power Supply		-	220-240V~ 50Hz	
Heat Exchange		-	Cross Fin Coil	
Fan	Type	-	Centrifugal fan	
	Drive	-	Direct	
	Motor Output	kW	-	
	Air Flow	m ³ /h	600	700
Sound Pressure Level(H/M/L)		dB(A)	29/26/24	33/30/27
Air Filter		-	PP	
Drain Piping		mm	ø17×1.75	ø17×1.75
Dimensions (W×H×D)	Outline	mm	1220×225×700	1220×225×700
	Package	mm	1343×315× 823	1343×315× 823
Weight(Net/Gross)		kg	38/47	39/48
Outdoor Unit			GUHD09NK3FO	GUHD12NK3FO
Power Supply		-	220-240V~ 50Hz	
Heat Exchange		-	Cross Fin Coil	
Fan	Type	-	Axial fan	
	Fan Motor Speed	rpm	860	860
Compressor	Type	-	ROTARY	ROTARY
	Power Input	W	942	942
Refrigerant	Type	-	R410A	
	Control	-	Capillary Tube	
	Charge	kg	1.2	1.2
Dimensions (W×H×D)	Outline	mm	848 ×540×320	848×540×320
	Package	mm	881×595×363	881×595×363
Weight(Net/Gross)		kg	34/37	34/37
Piping Connections	Liquid	Inch	ø1/4	ø1/4
	Gas	Inch	ø3/8	ø3/8
	Max. Length	m	20	20
	Max. Height	m	15	15

DC Inverter U-match Air Conditioners Technical Sales Guide

Model	Indoor unit		GTH18K3FI	GTH24K3FI	GTH30K3FI
	Outdoor unit		GUHD18NK3FO	GUHD24NK3FO	GUHD30NK3FO
Nominal Capacity	Cooling	kW	5.0	7	8.5
		Btu/h	17060	23884	29002
	Heating	kW	5.6	8	9.2
		Btu/h	19107	27296	31390
Power Input	Cooling	kW	1.55	2.18	2.67
	Heating	kW	1.55	2.21	2.57
EER/COP		W/W	3.23/3.61	3.21/3.62	3.18/3.58
Indoor Unit			GTH18K3FI	GTH24K3FI	GTH30K3FI
Power Supply		–	220-240V~ 50Hz		
Heat Exchange		–	Cross Fin Coil		
Fan	Type	–	Centrifugal fan		
	Drive	–	Direct	Direct	Direct
	Motor Output	kW	–		
	Air Flow	m ³ /h	1000	1200	1500
Sound Pressure Level(H/M/L)		dB(A)	42/38/32	48/46/40	46/44/38
Air Filter		–	PP		
Drain Piping		mm	ø17×1.75	ø17×1.75	ø17×1.75
Dimensions (W×H×D)	Outline	mm	1220×225×700	1220×225×700	1420×245×700
	Package	mm	1343×315×823	1343×315×823	1548×345×828
Weight(Net/Gross)		kg	39/48	40/50	48/56
Outdoor Unit			GUHD18NK3FO	GUHD24NK3FO	GUHD30NK3FO
Power Supply		–	220-240V~ 50Hz		
Heat Exchange		–	Cross Fin Coil		
Fan	Type	–	Axial fan		
	Fan Motor Speed	rpm	840	840	840
Compressor	Type	–	ROTARY	ROTARY	ROTARY
	Power Input	W	1440	2550	2550
Refrigerant	Type	–	R410A		
	Control	–	Electronic Expansion Valve		
	Charge	kg	1.4	2.2	2.4
Dimensions (W×H×D)	Outline	mm	955×700×396	980×790×427	980×790×427
	Package	mm	1029×750×458	1083×855×488	1083×855×488
Weight(Net/Gross)		kg	47/50	67/72	71/76
Piping Connections	Liquid	Inch	ø1/4	ø3/8	ø3/8
	Gas	Inch	ø1/2	ø5/8	ø5/8
	Max. Length	m	20	30	30
	Max. Height	m	15	15	15

Model	Indoor unit		GTH36K3FI	GTH36K3FI
	Outdoor unit		GUHD36NK3FO	GUHD36NM3FO
Nominal Capacity	Cooling	kW	10	10
		Btu/h	34120	34120
	Heating	kW	12	12
		Btu/h	40944	40944
Power Input	Cooling	kW	3.2	3.12
	Heating	kW	3.4	3.32
EER/COP		W/W	3.12/3.53	3.21/3.61
Indoor Unit			GTH36K3FI	GTH36K3FI
Power Supply		–	220-240V~ 50Hz	
Heat Exchange		–	Cross Fin Coil	
Fan	Type	–	Centrifugal fan	
	Drive	–	Direct	Direct
	Motor Output	kW	–	
	Air Flow	m ³ /h	1900	1900
Sound Pressure Level(H/M/L)		dB(A)	53/51/46	53/51/46
Air Filter		–	PP	
Drain Piping		mm	ø17×1.75	ø17×1.75
Dimensions (W×H×D)	Outline	mm	1420×245×700	1420×245×700
	Package	mm	1548×345×828	1548×345×828
Weight(Net/Gross)		kg	48/56	48/56
Outdoor Unit			GUHD36NK3FO	GUHD36NM3FO
Power Supply		–	220-240V~ 50Hz	380-415V 3N~ 50Hz
Heat Exchange		–	Cross Fin Coil	
Fan	Type	–	Axial fan	
	Fan Motor Speed	rpm	900	
Compressor	Type	–	ROTARY	
	Power Input	W	4150	4000
Refrigerant	Type	–	R410A	
	Control	–	Electronic Expansion Valve	
	Charge	kg	3.5	3.5
Dimensions (W×H×D)	Outline	mm	1107×1100×440	
	Package	mm	1158×1235×493	
Weight(Net/Gross)		kg	90/100	98/105
Piping Connections	Liquid	Inch	ø3/8	ø3/8
	Gas	Inch	ø5/8	ø5/8
	Max. Length	m	30	30
	Max. Height	m	15	15

DC Inverter U-match Air Conditioners Technical Sales Guide

Model	Indoor unit		GTH42K3FI	GTH42K3FI	GTH48K3FI
	Outdoor unit		GUHD42NK3FO	GUHD42NM3FO	GUHD48NK3FO
Nominal Capacity	Cooling	kW	11.5	11.5	14
		Btu/h	39238	39238	47768
	Heating	kW	13.5	13.5	16
		Btu/h	46062	46062	54592
Power Input	Cooling	kW	3.9	3.9	4.8
	Heating	kW	3.7	3.74	4.3
EER/COP		W/W	2.95/3.65	2.95/3.61	2.92/3.72
Indoor Unit			GTH42K3FI	GTH42K3FI	GTH48K3FI
Power Supply		–	220-240V~ 50Hz		
Heat Exchange		–	Cross Fin Coil		
Fan	Type	–	Centrifugal fan		
	Drive	–	Direct		
	Motor Output	kW	0.165	0.165	0.19
	Air Flow	m ³ /h	1250/1200/1000/860	1250/1200/1000/860	1300/1250/1000/900
Sound Pressure Level(H/M/L)		dB(A)	54/52/47	54/52/47	55/50/46
Air Filter		–	Standard washable synthetic		
Drain Piping		mm	ø17×1.75	ø17×1.75	ø17×1.75
Dimensions (W×H×D)	Outline	mm	1420×245×700	1420×245×700	1700×245×700
	Package	mm	1548×345×828	1548×345×828	1828×345×828
Weight(Net/Gross)		kg	50/58	50/58	59/68
Outdoor Unit			GUHD42NK3FO	GUHD42NM3FO	GUHD48NK3FO
Power Supply		–	220-240V~ 50Hz	380-415V 3N~ 50Hz	220-240V~ 50Hz
Heat Exchange		–	Cross Fin Coil		Cross Fin Coil
Fan	Type	–	Axial fan	Axial fan	Axial fan
	Fan Motor Speed	rpm	820	820	820
Compressor	Type	–	ROTARY	ROTARY	ROTARY
	Power Input	W	4150	4000	4580
Refrigerant	Type	–	R410A		
	Control	–	Electronic Expansion Valve		
	Charge	kg	3.7	3.7	4.0
Dimensions (W×H×D)	Outline	mm	958×1349×412	958×1349×412	958×1349×412
	Package	mm	1043×1500×453	1043×1500×453	1043×1500×453
Weight(Net/Gross)		kg	95/105	108/118	105/115
Piping Connections	Liquid	Inch	ø3/8	ø3/8	ø3/8
	Gas	Inch	ø5/8	ø5/8	ø5/8
	Max. Length	m	50	50	50
	Max. Height	m	30	30	30

Model	Indoor unit		GTH48K3FI	GTH60K3FI
	Outdoor unit		GUHD48NM3FO	GUHD60NM3FO
Nominal Capacity	Cooling	kW	14	16
		Btu/h	47768	54592
	Heating	kW	16	17
		Btu/h	54592	58004
Power Input	Cooling	kW	5.0	5.75
	Heating	kW	4.5	4.7
EER/COP		W/W	2.8/3.56	2.78/3.62
Indoor Unit			GTH48K3FI	GTH60K3FI
Power Supply		-	220-240V~ 50Hz	
Heat Exchange		-	Cross Fin Coil	
Fan	Type	-	Centrifugal fan	
	Drive	-	Direct	Direct
	Motor Output	kW	0.19	0.20
	Air Flow	m ³ /h	1300/1250/1000/900	1380/1300/1100/900
Sound Pressure Level(H/M/L)		dB(A)	55/50/46	56/52/46
Air Filter		-	Standard washable synthetic	
Drain Piping		mm	ø17×1.75	ø17×1.75
Dimensions (W×H×D)	Outline	mm	1700×245×700	1700×245×700
	Package	mm	1828×345×828	1828×345×828
Weight(Net/Gross)		kg	59/68	65/73
Outdoor Unit			GUHD48NM3FO	GUHD60NM3FO
Power Supply		-	380-415V 3N~ 50Hz	
Heat Exchange		-	Cross Fin Coil	
Fan	Type	-	Axial fan	
	Fan Motor Speed	rpm	820	820
Compressor	Type	-	ROTARY	ROTARY
	Power Input	W	4580	4580
Refrigerant	Type	-	R410A	
	Control	-	Electronic Expansion Valve	
	Charge	kg	4.0	5.0
Dimensions (W×H×D)	Outline	mm	958×1349×412	1085×1365×427
	Package	mm	1043×1500×453	1143×1505×478
Weight(Net/Gross)		kg	114/124	126/138
Piping Connections	Liquid	Inch	ø3/8	ø3/8
	Gas	Inch	ø5/8	ø3/4
	Max. Length	m	50	50
	Max. Height	m	30	30

Note:

- The design of this unit conforms to the requirements of EN14511 standard.
- The air volume is measured at the relevant standard external static pressure.
- Cooling (heating) capacity stated above is measured under nominal working conditions corresponding to standard external static pressure. The parameters are subject to change with the improvement of products, in which case the values on nameplate shall prevail.

		Indoor	Outdoor
Cooling		DB:27°C(80.6°F) WB:19°C(66.2°F)	DB:35°C(95°F) WB:24°C(75.2°F)
Heating		DB:20°C(68°F) WB:-°C(--°F)	DB:7°C(44.6°F) WB:6°C(42.8°F)
Piping Length	18~42K	5m	
	48/60K	7.5m	



4.2 Operation Range

Mode	Range of Outdoor Temperature °C(°F)
Cooling	-15°C(5°F)— 48°C (118.4°F)
Heating	-10°C(14°F) — 24°C (75.2°F)

DC Inverter U-match Air Conditioners Technical Sales Guide

Fan Speed	Air Flow Rate		ESP		Entering Air DBT		Outdoor Air Dry Bulb Temperature 110°F(43°C)											
							Indoor Air Wet Bulb Temperature °F(°C)											
							62°F(17°C)				67°F(19°C)				72°F(22°C)			
							Total Capacity		Sensible Capacity		Total Capacity		Sensible Capacity		Total Capacity		Sensible Capacity	
m ³ /hr	cfm	Pa	in.wg	°C	°F	kW	Mbh	kW	Mbh	kW	Mbh	kW	Mbh	kW	Mbh	kW	Mbh	
High	920	541	0	0	23	73.4	2.30	7.86	1.73	5.90	2.62	8.93	1.83	6.25	2.70	9.20	1.46	4.97
					24	75.2	2.33	7.94	1.86	6.35	2.64	9.02	1.93	6.59	2.72	9.29	1.61	5.48
					27	80.6	2.35	8.02	1.90	6.50	2.67	9.11	2.03	6.93	2.75	9.39	1.79	6.10
					31	87.8	2.37	8.10	1.99	6.80	2.70	9.21	2.13	7.27	2.78	9.48	1.95	6.64
	780	459	15	0.06	23	73.4	2.17	7.42	1.63	5.56	2.47	8.43	1.73	5.90	2.54	8.68	1.37	4.69
					24	75.2	2.20	7.49	1.76	5.99	2.49	8.51	1.82	6.21	2.57	8.77	1.52	5.17
					27	80.6	2.22	7.57	1.80	6.13	2.52	8.60	1.92	6.53	2.60	8.86	1.69	5.76
					31	87.8	2.24	7.64	1.88	6.42	2.55	8.68	2.01	6.86	2.62	8.94	1.84	6.26
	650	383	25	0.1	23	73.4	2.06	7.04	1.55	5.28	2.35	8.00	1.64	5.60	2.42	8.25	1.30	4.45
					24	75.2	2.09	7.12	1.67	5.69	2.37	8.09	1.73	5.90	2.44	8.33	1.44	4.91
					27	80.6	2.11	7.19	1.71	5.82	2.39	8.17	1.82	6.21	2.47	8.41	1.60	5.47
					31	87.8	2.13	7.26	1.79	6.10	2.42	8.25	1.91	6.52	2.49	8.50	1.74	5.95
	600	353	30	0.12	23	73.4	1.91	6.53	1.43	4.89	2.17	7.42	1.52	5.19	2.24	7.64	1.21	4.12
					24	75.2	1.93	6.59	1.55	5.27	2.20	7.49	1.60	5.47	2.26	7.72	1.33	4.55
					27	80.6	1.95	6.66	1.58	5.39	2.22	7.57	1.69	5.75	2.28	7.79	1.48	5.07
					31	87.8	1.97	6.73	1.66	5.65	2.24	7.64	1.77	6.04	2.31	7.87	1.61	5.51

Fan Speed	Air Flow Rate		ESP		Entering Air DBT		Outdoor Air Dry Bulb Temperature 77°F(25°C)											
							Indoor Air Wet Bulb Temperature °F(°C)											
							62°F(17°C)				67°F(19°C)				72°F(22°C)			
							Total Capacity		Sensible Capacity		Total Capacity		Sensible Capacity		Total Capacity		Sensible Capacity	
m ³ /hr	cfm	Pa	in.wg	°C	°F	kW	Mbh	kW	Mbh	kW	Mbh	kW	Mbh	kW	Mbh	kW	Mbh	
Medium	860	506	0	0	23	73.4	2.67	9.13	2.01	6.84	3.04	10.37	2.13	7.26	3.13	10.68	1.69	5.77
					24	75.2	2.70	9.22	2.16	7.38	3.07	10.48	2.24	7.65	3.16	10.79	1.87	6.37
					27	80.6	2.73	9.31	2.21	7.54	3.10	10.58	2.36	8.04	3.19	10.90	2.08	7.08
					31	87.8	2.76	9.41	2.32	7.90	3.13	10.69	2.47	8.44	3.23	11.01	2.26	7.71
	720	424	15	0.06	23	73.4	2.52	8.61	1.89	6.46	2.87	9.78	2.01	6.85	2.95	10.08	1.59	5.44
					24	75.2	2.55	8.70	2.04	6.96	2.90	9.88	2.11	7.22	2.98	10.18	1.76	6.01
					27	80.6	2.57	8.79	2.09	7.12	2.93	9.98	2.22	7.59	3.01	10.28	1.96	6.68
					31	87.8	2.60	8.87	2.18	7.45	2.96	10.08	2.33	7.97	3.04	10.39	2.13	7.27
	580	341	25	0.1	23	73.4	2.40	8.18	1.80	6.13	2.72	9.29	1.91	6.51	2.81	9.57	1.52	5.17
					24	75.2	2.42	8.26	1.94	6.61	2.75	9.39	2.01	6.85	2.83	9.67	1.67	5.71
					27	80.6	2.45	8.35	1.98	6.76	2.78	9.48	2.11	7.21	2.86	9.77	1.86	6.35
					31	87.8	2.47	8.43	2.08	7.08	2.81	9.58	2.22	7.57	2.89	9.87	2.02	6.91
	520	306	30	0.12	23	73.4	2.22	7.58	1.67	5.68	2.52	8.61	1.77	6.03	2.60	8.87	1.40	4.79
					24	75.2	2.24	7.65	1.79	6.12	2.55	8.70	1.86	6.35	2.63	8.96	1.55	5.29
					27	80.6	2.27	7.73	1.84	6.26	2.57	8.79	1.96	6.68	2.65	9.05	1.72	5.88
					31	87.8	2.29	7.81	1.92	6.56	2.60	8.87	2.05	7.01	2.68	9.14	1.88	6.40

Fan Speed	Air Flow Rate		ESP		Entering Air DBT		Outdoor Air Dry Bulb Temperature 95°F(35°C)											
							Indoor Air Wet Bulb Temperature °F(°C)											
							62°F(17°C)				67°F(19°C)				72°F(22°C)			
							Total Capacity		Sensible Capacity		Total Capacity		Sensible Capacity		Total Capacity		Sensible Capacity	
m ³ /hr	cfm	Pa	in.wg	°C	°F	kW	Mbh	kW	Mbh	kW	Mbh	kW	Mbh	kW	Mbh	kW	Mbh	
Medium	860	506	0	0	23	73.4	2.43	8.30	1.82	6.22	2.76	9.43	1.93	6.60	2.85	9.71	1.54	5.24
					24	75.2	2.46	8.38	1.97	6.71	2.79	9.52	2.04	6.95	2.88	9.81	1.70	5.79
					27	80.6	2.48	8.47	2.01	6.86	2.82	9.62	2.14	7.31	2.90	9.91	1.89	6.44
					31	87.8	2.51	8.55	2.11	7.18	2.85	9.72	2.25	7.68	2.93	10.01	2.05	7.01
	720	424	15	0.06	23	73.4	2.29	7.83	1.72	5.87	2.61	8.89	1.82	6.23	2.69	9.16	1.45	4.95
					24	75.2	2.32	7.91	1.85	6.33	2.63	8.99	1.92	6.56	2.71	9.25	1.60	5.46
					27	80.6	2.34	7.99	1.90	6.47	2.66	9.08	2.02	6.90	2.74	9.35	1.78	6.08
					31	87.8	2.36	8.07	1.99	6.78	2.69	9.17	2.12	7.24	2.77	9.44	1.94	6.61
	580	341	25	0.1	23	73.4	2.18	7.44	1.63	5.58	2.48	8.45	1.73	5.91	2.55	8.70	1.38	4.70
					24	75.2	2.20	7.51	1.76	6.01	2.50	8.54	1.83	6.23	2.58	8.79	1.52	5.19
					27	80.6	2.22	7.59	1.80	6.15	2.53	8.62	1.92	6.55	2.60	8.88	1.69	5.77
					31	87.8	2.25	7.66	1.89	6.44	2.55	8.71	2.02	6.88	2.63	8.97	1.84	6.28
	520	306	30	0.12	23	73.4	2.02	6.89	1.51	5.17	2.29	7.83	1.61	5.48	2.36	8.06	1.28	4.35
					24	75.2	2.04	6.96	1.63	5.57	2.32	7.91	1.69	5.77	2.39	8.14	1.41	4.81
					27	80.6	2.06	7.03	1.67	5.69	2.34	7.99	1.78	6.07	2.41	8.23	1.57	5.35
					31	87.8	2.08	7.10	1.75	5.96	2.36	8.07	1.87	6.37	2.44	8.31	1.70	5.82

Fan Speed	Air Flow Rate		ESP		Entering Air DBT		Outdoor Air Dry Bulb Temperature 110°F(43°C)											
							Indoor Air Wet Bulb Temperature °F(°C)											
							62°F(17°C)				67°F(19°C)				72°F(22°C)			
							Total Capacity		Sensible Capacity		Total Capacity		Sensible Capacity		Total Capacity		Sensible Capacity	
m ³ /hr	cfm	Pa	in.wg	°C	°F	kW	Mbh	kW	Mbh	kW	Mbh	kW	Mbh	kW	Mbh	kW	Mbh	
Medium	860	506	0	0	23	73.4	2.19	7.47	1.64	5.60	2.49	8.49	1.74	5.94	2.56	8.74	1.38	4.72
					24	75.2	2.21	7.54	1.77	6.03	2.51	8.57	1.83	6.26	2.59	8.83	1.53	5.21
					27	80.6	2.23	7.62	1.81	6.17	2.54	8.66	1.93	6.58	2.61	8.92	1.70	5.80
					31	87.8	2.26	7.70	1.89	6.46	2.56	8.75	2.02	6.91	2.64	9.01	1.85	6.31
	720	424	15	0.06	23	73.4	2.06	7.04	1.55	5.28	2.35	8.00	1.64	5.60	2.42	8.25	1.30	4.45
					24	75.2	2.09	7.12	1.67	5.69	2.37	8.09	1.73	5.90	2.44	8.33	1.44	4.91
					27	80.6	2.11	7.19	1.71	5.82	2.39	8.17	1.82	6.21	2.47	8.41	1.60	5.47
					31	87.8	2.13	7.26	1.79	6.10	2.42	8.25	1.91	6.52	2.49	8.50	1.74	5.95
	580	341	25	0.1	23	73.4	1.96	6.69	1.47	5.02	2.23	7.60	1.56	5.32	2.30	7.83	1.24	4.23
					24	75.2	1.98	6.76	1.59	5.41	2.25	7.68	1.64	5.61	2.32	7.91	1.37	4.67
					27	80.6	2.00	6.83	1.62	5.53	2.27	7.76	1.73	5.90	2.34	7.99	1.52	5.20
					31	87.8	2.02	6.90	1.70	5.79	2.30	7.84	1.81	6.19	2.37	8.07	1.66	5.65
	520	306	30	0.12	23	73.4	1.82	6.20	1.36	4.65	2.06	7.04	1.45	4.93	2.13	7.26	1.15	3.92
					24	75.2	1.84	6.26	1.47	5.01	2.09	7.12	1.52	5.19	2.15	7.33	1.27	4.32
					27	80.6	1.85	6.33	1.50	5.12	2.11	7.19	1.60	5.46	2.17	7.40	1.41	4.81
					31	87.8	1.87	6.39	1.57	5.37	2.13	7.26	1.68	5.74	2.19	7.48	1.53	5.23

DC Inverter U-match Air Conditioners Technical Sales Guide

Fan Speed	Air Flow Rate		ESP		Entering Air DBT		Outdoor Air Dry Bulb Temperature 77°F(25°C)											
							Indoor Air Wet Bulb Temperature °F(°C)											
					62°F(17°C)		67°F(19°C)		72°F(22°C)									
	m ³ /hr	cfm	Pa	in.wg	°C	°F	Total Capacity	Sensible Capacity	Total Capacity	Sensible Capacity	Total Capacity	Sensible Capacity	Total Capacity	Sensible Capacity				
						kW	Mbh	kW	Mbh	kW	Mbh	kW	Mbh	kW	Mbh	kW	Mbh	
Low	760	447	0	0	23	73.4	2.53	8.65	1.90	6.48	2.88	9.83	2.02	6.88	2.97	10.12	1.60	5.46
					24	75.2	2.56	8.73	2.05	6.99	2.91	9.93	2.12	7.25	3.00	10.22	1.77	6.03
					27	80.6	2.59	8.82	2.09	7.15	2.94	10.03	2.23	7.62	3.03	10.33	1.97	6.71
					31	87.8	2.61	8.91	2.19	7.48	2.97	10.13	2.34	8.00	3.06	10.43	2.14	7.30
	620	365	15	0.06	23	73.4	2.39	8.16	1.79	6.12	2.72	9.27	1.90	6.49	2.80	9.55	1.51	5.16
					24	75.2	2.41	8.24	1.93	6.59	2.74	9.36	2.00	6.84	2.83	9.64	1.67	5.69
					27	80.6	2.44	8.32	1.98	6.74	2.77	9.46	2.11	7.19	2.86	9.74	1.86	6.33
					31	87.8	2.46	8.41	2.07	7.06	2.80	9.55	2.21	7.55	2.88	9.84	2.02	6.89
	480	283	25	0.1	23	73.4	2.27	7.75	1.70	5.81	2.58	8.81	1.81	6.16	2.66	9.07	1.44	4.90
					24	75.2	2.29	7.83	1.84	6.26	2.61	8.90	1.90	6.49	2.69	9.16	1.58	5.41
					27	80.6	2.32	7.91	1.88	6.40	2.63	8.99	2.00	6.83	2.71	9.25	1.76	6.02
					31	87.8	2.34	7.99	1.97	6.71	2.66	9.08	2.10	7.17	2.74	9.35	1.92	6.54
	400	235	30	0.12	23	73.4	2.10	7.18	1.58	5.38	2.39	8.16	1.67	5.71	2.46	8.40	1.33	4.54
					24	75.2	2.13	7.25	1.70	5.80	2.41	8.24	1.76	6.02	2.49	8.49	1.47	5.01
					27	80.6	2.15	7.32	1.74	5.93	2.44	8.32	1.85	6.33	2.51	8.57	1.63	5.57
					31	87.8	2.17	7.40	1.82	6.21	2.46	8.41	1.95	6.64	2.54	8.66	1.78	6.06

Fan Speed	Air Flow Rate		ESP		Entering Air DBT		Outdoor Air Dry Bulb Temperature 95°F(35°C)											
							Indoor Air Wet Bulb Temperature °F(°C)											
					62°F(17°C)		67°F(19°C)		72°F(22°C)									
	m ³ /hr	cfm	Pa	in.wg	°C	°F	Total Capacity	Sensible Capacity	Total Capacity	Sensible Capacity	Total Capacity	Sensible Capacity	Total Capacity	Sensible Capacity				
						kW	Mbh	kW	Mbh	kW	Mbh	kW	Mbh	kW	Mbh	kW	Mbh	
Low	760	447	0	0	23	73.4	2.30	7.86	1.73	5.90	2.62	8.93	1.83	6.25	2.70	9.20	1.46	4.97
					24	75.2	2.33	7.94	1.86	6.35	2.64	9.02	1.93	6.59	2.72	9.29	1.61	5.48
					27	80.6	2.35	8.02	1.90	6.50	2.67	9.11	2.03	6.93	2.75	9.39	1.79	6.10
					31	87.8	2.37	8.10	1.99	6.80	2.70	9.21	2.13	7.27	2.78	9.48	1.95	6.64
	620	365	15	0.06	23	73.4	2.17	7.42	1.63	5.56	2.47	8.43	1.73	5.90	2.54	8.68	1.37	4.69
					24	75.2	2.20	7.49	1.76	5.99	2.49	8.51	1.82	6.21	2.57	8.77	1.52	5.17
					27	80.6	2.22	7.57	1.80	6.13	2.52	8.60	1.92	6.53	2.60	8.86	1.69	5.76
					31	87.8	2.24	7.64	1.88	6.42	2.55	8.68	2.01	6.86	2.62	8.94	1.84	6.26
	480	283	25	0.1	23	73.4	2.06	7.04	1.55	5.28	2.35	8.00	1.64	5.60	2.42	8.25	1.30	4.45
					24	75.2	2.09	7.12	1.67	5.69	2.37	8.09	1.73	5.90	2.44	8.33	1.44	4.91
					27	80.6	2.11	7.19	1.71	5.82	2.39	8.17	1.82	6.21	2.47	8.41	1.60	5.47
					31	87.8	2.13	7.26	1.79	6.10	2.42	8.25	1.91	6.52	2.49	8.50	1.74	5.95
	400	235	30	0.12	23	73.4	1.91	6.53	1.43	4.89	2.17	7.42	1.52	5.19	2.24	7.64	1.21	4.12
					24	75.2	1.93	6.59	1.55	5.27	2.20	7.49	1.60	5.47	2.26	7.72	1.33	4.55
					27	80.6	1.95	6.66	1.58	5.39	2.22	7.57	1.69	5.75	2.28	7.79	1.48	5.07
					31	87.8	1.97	6.73	1.66	5.65	2.24	7.64	1.77	6.04	2.31	7.87	1.61	5.51

Fan Speed	Air Flow Rate		ESP		Entering Air DBT		Outdoor Air Dry Bulb Temperature 110°F(43°C)											
							Indoor Air Wet Bulb Temperature °F(°C)											
	m ³ /hr cfm		Pa in.wg		°C °F		62°F(17°C)		67°F(19°C)		72°F(22°C)		72°F(22°C)					
							Total Capacity	Sensible Capacity	Total Capacity	Sensible Capacity	Total Capacity	Sensible Capacity	Total Capacity	Sensible Capacity				
						kW	Mbh	kW	Mbh	kW	Mbh	kW	Mbh	kW	Mbh	kW	Mbh	
Low	760	447	0	0	23	73.4	2.07	7.07	1.55	5.31	2.36	8.04	1.65	5.63	2.43	8.28	1.31	4.47
					24	75.2	2.09	7.15	1.68	5.72	2.38	8.12	1.74	5.93	2.45	8.36	1.45	4.93
					27	80.6	2.12	7.22	1.71	5.85	2.40	8.20	1.83	6.23	2.48	8.45	1.61	5.49
					31	87.8	2.14	7.29	1.79	6.12	2.43	8.28	1.92	6.54	2.50	8.53	1.75	5.97
	620	365	15	0.06	23	73.4	1.96	6.67	1.47	5.01	2.22	7.58	1.56	5.31	2.29	7.81	1.24	4.22
					24	75.2	1.98	6.74	1.58	5.39	2.25	7.66	1.64	5.59	2.31	7.89	1.36	4.66
					27	80.6	2.00	6.81	1.62	5.52	2.27	7.74	1.72	5.88	2.34	7.97	1.52	5.18
					31	87.8	2.02	6.88	1.69	5.78	2.29	7.82	1.81	6.17	2.36	8.05	1.65	5.64
	480	283	25	0.1	23	73.4	1.86	6.34	1.39	4.75	2.11	7.20	1.48	5.04	2.17	7.42	1.17	4.01
					24	75.2	1.88	6.40	1.50	5.12	2.13	7.28	1.56	5.31	2.20	7.50	1.30	4.42
					27	80.6	1.90	6.47	1.54	5.24	2.15	7.35	1.64	5.59	2.22	7.57	1.44	4.92
					31	87.8	1.92	6.53	1.61	5.49	2.18	7.43	1.72	5.87	2.24	7.65	1.57	5.35
	400	235	30	0.12	23	73.4	1.72	5.87	1.29	4.40	1.96	6.67	1.37	4.67	2.01	6.87	1.09	3.71
					24	75.2	1.74	5.93	1.39	4.75	1.98	6.74	1.44	4.92	2.04	6.94	1.20	4.10
					27	80.6	1.76	5.99	1.42	4.85	2.00	6.81	1.52	5.18	2.06	7.01	1.34	4.56
					31	87.8	1.77	6.05	1.49	5.08	2.02	6.88	1.59	5.43	2.08	7.08	1.45	4.96

GFH12K3FI:

Fan Speed	Air Flow Rate		ESP		Entering Air DBT		Outdoor Air Dry Bulb Temperature 77°F(25°C)											
							Indoor Air Wet Bulb Temperature °F(°C)											
	m ³ /hr cfm		Pa in.wg		°C °F		62°F(17°C)		67°F(19°C)		72°F(22°C)		72°F(22°C)					
							Total Capacity	Sensible Capacity	Total Capacity	Sensible Capacity	Total Capacity	Sensible Capacity	Total Capacity	Sensible Capacity				
						kW	Mbh	kW	Mbh	kW	Mbh	kW	Mbh	kW	Mbh	kW	Mbh	
High	980	577	0	0	23	73.4	3.80	12.97	2.85	9.73	4.32	14.74	3.02	10.32	4.45	15.18	2.40	8.20
					24	75.2	3.84	13.10	3.07	10.48	4.36	14.89	3.19	10.87	4.49	15.33	2.65	9.05
					27	80.6	3.88	13.23	3.14	10.72	4.41	15.04	3.35	11.43	4.54	15.49	2.95	10.07
					31	87.8	3.92	13.37	3.29	11.23	4.45	15.19	3.52	12.00	4.59	15.64	3.21	10.95
	860	506	15	0.06	23	73.4	3.59	12.23	2.69	9.18	4.07	13.90	2.85	9.73	4.20	14.32	2.27	7.73
					24	75.2	3.62	12.36	2.90	9.89	4.12	14.05	3.00	10.25	4.24	14.47	2.50	8.54
					27	80.6	3.66	12.48	2.96	10.11	4.16	14.19	3.16	10.78	4.28	14.61	2.78	9.50
					31	87.8	3.70	12.61	3.10	10.59	4.20	14.33	3.32	11.32	4.33	14.76	3.03	10.33
	750	441	25	0.1	23	73.4	3.41	11.62	2.55	8.72	3.87	13.21	2.71	9.25	3.99	13.60	2.15	7.35
					24	75.2	3.44	11.74	2.75	9.39	3.91	13.34	2.85	9.74	4.03	13.74	2.38	8.11
					27	80.6	3.48	11.86	2.82	9.61	3.95	13.48	3.00	10.24	4.07	13.88	2.64	9.02
					31	87.8	3.51	11.98	2.95	10.06	3.99	13.61	3.15	10.75	4.11	14.02	2.88	9.81
	700	412	30	0.12	23	73.4	3.16	10.77	2.37	8.08	3.59	12.23	2.51	8.56	3.69	12.60	1.99	6.81
					24	75.2	3.19	10.88	2.55	8.70	3.62	12.36	2.64	9.02	3.73	12.73	2.20	7.51
					27	80.6	3.22	10.99	2.61	8.90	3.66	12.48	2.78	9.49	3.77	12.86	2.45	8.36
					31	87.8	3.25	11.10	2.73	9.32	3.70	12.61	2.92	9.96	3.81	12.99	2.66	9.09

DC Inverter U-match Air Conditioners Technical Sales Guide

Fan Speed	Air Flow Rate		ESP		Entering Air DBT		Outdoor Air Dry Bulb Temperature 95°F(35°C)													
							Indoor Air Wet Bulb Temperature °F(°C)													
			62°F(17°C)				67°F(19°C)				72°F(22°C)									
	m ³ /hr	cfm	Pa	in.wg	°C	°F	Total Capacity		Sensible Capacity		Total Capacity		Sensible Capacity		Total Capacity		Sensible Capacity			
						kW	Mbh	kW	Mbh	kW	Mbh	kW	Mbh	kW	Mbh	kW	Mbh	kW	Mbh	
High	980	577	0	0	23	73.4	3.46	11.79	2.59	8.84	3.93	13.40	2.75	9.38	4.04	13.80	2.18	7.45		
					24	75.2	3.49	11.91	2.79	9.53	3.97	13.53	2.90	9.88	4.09	13.94	2.41	8.22		
					27	80.6	3.53	12.03	2.86	9.74	4.01	13.67	3.05	10.39	4.13	14.08	2.68	9.15		
					31	87.8	3.56	12.15	2.99	10.21	4.05	13.81	3.20	10.91	4.17	14.22	2.92	9.96		
	860	506	15	0.06	23	73.4	3.26	11.12	2.44	8.34	3.70	12.64	2.59	8.85	3.82	13.02	2.06	7.03		
					24	75.2	3.29	11.24	2.63	8.99	3.74	12.77	2.73	9.32	3.85	13.15	2.27	7.76		
					27	80.6	3.33	11.35	2.69	9.19	3.78	12.90	2.87	9.80	3.89	13.28	2.53	8.63		
					31	87.8	3.36	11.46	2.82	9.63	3.82	13.03	3.02	10.29	3.93	13.42	2.75	9.39		
	750	441	25	0.1	23	73.4	3.10	10.57	2.32	7.92	3.52	12.01	2.46	8.41	3.62	12.37	1.96	6.68		
					24	75.2	3.13	10.67	2.50	8.54	3.56	12.13	2.60	8.85	3.66	12.49	2.16	7.37		
					27	80.6	3.16	10.78	2.56	8.73	3.59	12.25	2.73	9.31	3.70	12.62	2.40	8.20		
					31	87.8	3.19	10.89	2.68	9.15	3.63	12.38	2.87	9.78	3.74	12.75	2.62	8.92		
	700	412	30	0.12	23	73.4	2.87	9.79	2.15	7.34	3.26	11.12	2.28	7.79	3.36	11.46	1.81	6.19		
					24	75.2	2.90	9.89	2.32	7.91	3.29	11.24	2.40	8.20	3.39	11.57	2.00	6.83		
					27	80.6	2.93	9.99	2.37	8.09	3.33	11.35	2.53	8.63	3.43	11.69	2.23	7.60		
					31	87.8	2.96	10.09	2.48	8.47	3.36	11.46	2.65	9.06	3.46	11.81	2.42	8.26		

Fan Speed	Air Flow Rate		ESP		Entering Air DBT		Outdoor Air Dry Bulb Temperature 110°F(43°C)													
							Indoor Air Wet Bulb Temperature °F(°C)													
			62°F(17°C)				67°F(19°C)				72°F(22°C)									
	m ³ /hr	cfm	Pa	in.wg	°C	°F	Total Capacity		Sensible Capacity		Total Capacity		Sensible Capacity		Total Capacity		Sensible Capacity			
						kW	Mbh	kW	Mbh	kW	Mbh	kW	Mbh	kW	Mbh	kW	Mbh	kW	Mbh	
High	980	577	0	0	23	73.4	3.11	10.61	2.33	7.96	3.53	12.06	2.47	8.44	3.64	12.42	1.97	6.71		
					24	75.2	3.14	10.72	2.51	8.58	3.57	12.18	2.61	8.89	3.68	12.55	2.17	7.40		
					27	80.6	3.17	10.83	2.57	8.77	3.61	12.30	2.74	9.35	3.71	12.67	2.41	8.24		
					31	87.8	3.21	10.94	2.69	9.19	3.64	12.43	2.88	9.82	3.75	12.80	2.63	8.96		
	860	506	15	0.06	23	73.4	2.93	10.01	2.20	7.51	3.33	11.38	2.33	7.96	3.43	11.72	1.85	6.33		
					24	75.2	2.96	10.11	2.37	8.09	3.37	11.49	2.46	8.39	3.47	11.84	2.05	6.98		
					27	80.6	2.99	10.21	2.42	8.27	3.40	11.61	2.59	8.82	3.50	11.96	2.28	7.77		
					31	87.8	3.02	10.32	2.54	8.67	3.44	11.72	2.71	9.26	3.54	12.08	2.48	8.45		
	750	441	25	0.1	23	73.4	2.79	9.51	2.09	7.13	3.17	10.81	2.22	7.56	3.26	11.13	1.76	6.01		
					24	75.2	2.82	9.61	2.25	7.69	3.20	10.92	2.34	7.97	3.30	11.24	1.94	6.63		
					27	80.6	2.84	9.70	2.30	7.86	3.23	11.03	2.46	8.38	3.33	11.36	2.16	7.38		
					31	87.8	2.87	9.80	2.41	8.23	3.26	11.14	2.58	8.80	3.36	11.47	2.35	8.03		
	700	412	30	0.12	23	73.4	2.58	8.81	1.94	6.61	2.93	10.01	2.05	7.01	3.02	10.31	1.63	5.57		
					24	75.2	2.61	8.90	2.09	7.12	2.96	10.11	2.16	7.38	3.05	10.42	1.80	6.15		
					27	80.6	2.63	8.99	2.13	7.28	2.99	10.21	2.28	7.76	3.08	10.52	2.00	6.84		
					31	87.8	2.66	9.08	2.24	7.63	3.02	10.32	2.39	8.15	3.11	10.63	2.18	7.44		

Fan Speed	Air Flow Rate		ESP		Entering Air DBT		Outdoor Air Dry Bulb Temperature 77°F(25°C)											
							Indoor Air Wet Bulb Temperature °F(°C)											
							62°F(17°C)				67°F(19°C)				72°F(22°C)			
							Total Capacity		Sensible Capacity		Total Capacity		Sensible Capacity		Total Capacity		Sensible Capacity	
m ³ /hr	cfm	Pa	in.wg	°C	°F	kW	Mbh	kW	Mbh	kW	Mbh	kW	Mbh	kW	Mbh	kW	Mbh	
Medium	920	541	0	0	23	73.4	3.61	12.32	2.71	9.24	4.10	14.00	2.87	9.80	4.23	14.42	2.28	7.79
					24	75.2	3.65	12.45	2.92	9.96	4.15	14.14	3.03	10.32	4.27	14.57	2.52	8.60
					27	80.6	3.68	12.57	2.98	10.18	4.19	14.29	3.18	10.86	4.31	14.71	2.80	9.56
					31	87.8	3.72	12.70	3.13	10.67	4.23	14.43	3.34	11.40	4.36	14.86	3.05	10.40
	780	459	15	0.06	23	73.4	3.41	11.62	2.55	8.72	3.87	13.21	2.71	9.25	3.99	13.60	2.15	7.35
					24	75.2	3.44	11.74	2.75	9.39	3.91	13.34	2.85	9.74	4.03	13.74	2.38	8.11
					27	80.6	3.48	11.86	2.82	9.61	3.95	13.48	3.00	10.24	4.07	13.88	2.64	9.02
					31	87.8	3.51	11.98	2.95	10.06	3.99	13.61	3.15	10.75	4.11	14.02	2.88	9.81
	650	383	25	0.1	23	73.4	3.24	11.04	2.43	8.28	3.68	12.55	2.57	8.78	3.79	12.92	2.05	6.98
					24	75.2	3.27	11.15	2.62	8.92	3.72	12.68	2.71	9.25	3.83	13.06	2.26	7.70
					27	80.6	3.30	11.27	2.67	9.13	3.75	12.80	2.85	9.73	3.87	13.19	2.51	8.57
					31	87.8	3.34	11.38	2.80	9.56	3.79	12.93	2.99	10.22	3.90	13.32	2.73	9.32
	570	335	30	0.12	23	73.4	3.00	10.23	2.25	7.67	3.41	11.62	2.38	8.14	3.51	11.97	1.89	6.46
					24	75.2	3.03	10.33	2.42	8.27	3.44	11.74	2.51	8.57	3.54	12.09	2.09	7.14
					27	80.6	3.06	10.44	2.48	8.45	3.48	11.86	2.64	9.01	3.58	12.22	2.33	7.94
					31	87.8	3.09	10.54	2.60	8.85	3.51	11.98	2.77	9.46	3.62	12.34	2.53	8.64

Fan Speed	Air Flow Rate		ESP		Entering Air DBT		Outdoor Air Dry Bulb Temperature 95°F(35°C)											
							Indoor Air Wet Bulb Temperature °F(°C)											
							62°F(17°C)				67°F(19°C)				72°F(22°C)			
							Total Capacity		Sensible Capacity		Total Capacity		Sensible Capacity		Total Capacity		Sensible Capacity	
m ³ /hr	cfm	Pa	in.wg	°C	°F	kW	Mbh	kW	Mbh	kW	Mbh	kW	Mbh	kW	Mbh	kW	Mbh	
Medium	920	541	0	0	23	73.4	3.28	11.20	2.46	8.40	3.73	12.73	2.61	8.91	3.84	13.11	2.07	7.08
					24	75.2	3.32	11.31	2.65	9.05	3.77	12.86	2.75	9.39	3.88	13.24	2.29	7.81
					27	80.6	3.35	11.43	2.71	9.26	3.81	12.99	2.89	9.87	3.92	13.38	2.55	8.70
					31	87.8	3.38	11.54	2.84	9.70	3.84	13.12	3.04	10.36	3.96	13.51	2.77	9.46
	780	459	15	0.06	23	73.4	3.10	10.57	2.32	7.92	3.52	12.01	2.46	8.41	3.62	12.37	1.96	6.68
					24	75.2	3.13	10.67	2.50	8.54	3.56	12.13	2.60	8.85	3.66	12.49	2.16	7.37
					27	80.6	3.16	10.78	2.56	8.73	3.59	12.25	2.73	9.31	3.70	12.62	2.40	8.20
					31	87.8	3.19	10.89	2.68	9.15	3.63	12.38	2.87	9.78	3.74	12.75	2.62	8.92
	650	383	25	0.1	23	73.4	2.94	10.04	2.21	7.53	3.34	11.41	2.34	7.98	3.44	11.75	1.86	6.34
					24	75.2	2.97	10.14	2.38	8.11	3.38	11.52	2.47	8.41	3.48	11.87	2.05	7.00
					27	80.6	3.00	10.24	2.43	8.30	3.41	11.64	2.59	8.85	3.51	11.99	2.28	7.79
					31	87.8	3.03	10.35	2.55	8.69	3.45	11.76	2.72	9.29	3.55	12.11	2.48	8.48
	570	335	30	0.12	23	73.4	2.73	9.30	2.04	6.97	3.10	10.57	2.17	7.40	3.19	10.88	1.72	5.88
					24	75.2	2.75	9.39	2.20	7.51	3.13	10.67	2.28	7.79	3.22	10.99	1.90	6.49
					27	80.6	2.78	9.49	2.25	7.69	3.16	10.78	2.40	8.19	3.25	11.11	2.12	7.22
					31	87.8	2.81	9.58	2.36	8.05	3.19	10.89	2.52	8.60	3.29	11.22	2.30	7.85

DC Inverter U-match Air Conditioners Technical Sales Guide

Fan Speed	Air Flow Rate		ESP		Entering Air DBT		Outdoor Air Dry Bulb Temperature 110°F(43°C)												
							Indoor Air Wet Bulb Temperature °F(°C)												
			62°F(17°C)				67°F(19°C)				72°F(22°C)								
	m ³ /hr	cfm	Pa	in.wg	°C	°F	Total Capacity		Sensible Capacity		Total Capacity		Sensible Capacity		Total Capacity		Sensible Capacity		
						kW	Mbh	kW	Mbh	kW	Mbh	kW	Mbh	kW	Mbh	kW	Mbh	kW	Mbh
Medium	920	541	0	0	23	73.4	2.95	10.08	2.22	7.56	3.36	11.46	2.35	8.02	3.46	11.80	1.87	6.37	
					24	75.2	2.98	10.18	2.39	8.15	3.39	11.57	2.48	8.45	3.49	11.92	2.06	7.03	
					27	80.6	3.01	10.29	2.44	8.33	3.43	11.69	2.60	8.88	3.53	12.04	2.29	7.83	
					31	87.8	3.04	10.39	2.56	8.73	3.46	11.81	2.73	9.33	3.56	12.16	2.49	8.51	
	780	459	15	0.06	23	73.4	2.79	9.51	2.09	7.13	3.17	10.81	2.22	7.56	3.26	11.13	1.76	6.01	
					24	75.2	2.82	9.61	2.25	7.69	3.20	10.92	2.34	7.97	3.30	11.24	1.94	6.63	
					27	80.6	2.84	9.70	2.30	7.86	3.23	11.03	2.46	8.38	3.33	11.36	2.16	7.38	
					31	87.8	2.87	9.80	2.41	8.23	3.26	11.14	2.58	8.80	3.36	11.47	2.35	8.03	
	650	383	25	0.1	23	73.4	2.65	9.03	1.99	6.78	3.01	10.27	2.11	7.19	3.10	10.57	1.67	5.71	
					24	75.2	2.67	9.13	2.14	7.30	3.04	10.37	2.22	7.57	3.13	10.68	1.85	6.30	
					27	80.6	2.70	9.22	2.19	7.47	3.07	10.48	2.33	7.96	3.16	10.79	2.06	7.01	
					31	87.8	2.73	9.31	2.29	7.82	3.10	10.58	2.45	8.36	3.19	10.90	2.24	7.63	
	570	335	30	0.12	23	73.4	2.45	8.37	1.84	6.28	2.79	9.51	1.95	6.66	2.87	9.80	1.55	5.29	
					24	75.2	2.48	8.45	1.98	6.76	2.82	9.61	2.06	7.01	2.90	9.90	1.71	5.84	
					27	80.6	2.50	8.54	2.03	6.92	2.84	9.70	2.16	7.38	2.93	10.00	1.90	6.50	
					31	87.8	2.53	8.62	2.12	7.24	2.87	9.80	2.27	7.74	2.96	10.10	2.07	7.07	

Fan Speed	Air Flow Rate		ESP		Entering Air DBT		Outdoor Air Dry Bulb Temperature 77°F(25°C)												
							Indoor Air Wet Bulb Temperature °F(°C)												
			62°F(17°C)				67°F(19°C)				72°F(22°C)								
	m ³ /hr	cfm	Pa	in.wg	°C	°F	Total Capacity		Sensible Capacity		Total Capacity		Sensible Capacity		Total Capacity		Sensible Capacity		
						kW	Mbh	kW	Mbh	kW	Mbh	kW	Mbh	kW	Mbh	kW	Mbh	kW	Mbh
Low	860	506	0	0	23	73.4	3.42	11.67	2.57	8.75	3.89	13.26	2.72	9.28	4.00	13.66	2.16	7.38	
					24	75.2	3.46	11.79	2.76	9.43	3.93	13.40	2.87	9.78	4.04	13.80	2.39	8.14	
					27	80.6	3.49	11.91	2.83	9.65	3.97	13.53	3.01	10.29	4.09	13.94	2.66	9.06	
					31	87.8	3.53	12.03	2.96	10.10	4.01	13.67	3.17	10.80	4.13	14.08	2.89	9.86	
	720	424	15	0.06	23	73.4	3.23	11.01	2.42	8.26	3.67	12.51	2.57	8.76	3.78	12.89	2.04	6.96	
					24	75.2	3.26	11.12	2.61	8.90	3.70	12.64	2.70	9.23	3.82	13.02	2.25	7.68	
					27	80.6	3.29	11.24	2.67	9.10	3.74	12.77	2.84	9.70	3.85	13.15	2.51	8.55	
					31	87.8	3.33	11.35	2.79	9.53	3.78	12.90	2.99	10.19	3.89	13.28	2.73	9.30	
	560	330	25	0.1	23	73.4	3.07	10.46	2.30	7.85	3.48	11.89	2.44	8.32	3.59	12.24	1.94	6.61	
					24	75.2	3.10	10.57	2.48	8.45	3.52	12.01	2.57	8.77	3.63	12.37	2.14	7.30	
					27	80.6	3.13	10.67	2.53	8.65	3.56	12.13	2.70	9.22	3.66	12.49	2.38	8.12	
					31	87.8	3.16	10.78	2.65	9.06	3.59	12.25	2.84	9.68	3.70	12.62	2.59	8.83	
	480	283	30	0.12	23	73.4	2.84	9.69	2.13	7.27	3.23	11.01	2.26	7.71	3.32	11.34	1.80	6.12	
					24	75.2	2.87	9.79	2.30	7.83	3.26	11.12	2.38	8.12	3.36	11.46	1.98	6.76	
					27	80.6	2.90	9.89	2.35	8.01	3.29	11.24	2.50	8.54	3.39	11.57	2.20	7.52	
					31	87.8	2.93	9.99	2.46	8.39	3.33	11.35	2.63	8.97	3.43	11.69	2.40	8.18	

Fan Speed	Air Flow Rate		ESP		Entering Air DBT		Outdoor Air Dry Bulb Temperature 95°F(35°C)											
							Indoor Air Wet Bulb Temperature °F(°C)											
							62°F(17°C)				67°F(19°C)				72°F(22°C)			
							Total Capacity		Sensible Capacity		Total Capacity		Sensible Capacity		Total Capacity		Sensible Capacity	
m ³ /hr	cfm	Pa	in.wg	°C	°F	kW	Mbh	kW	Mbh	kW	Mbh	kW	Mbh	kW	Mbh	kW	Mbh	
Low	860	506	0	0	23	73.4	3.11	10.61	2.33	7.96	3.53	12.06	2.47	8.44	3.64	12.42	1.97	6.71
					24	75.2	3.14	10.72	2.51	8.58	3.57	12.18	2.61	8.89	3.68	12.55	2.17	7.40
					27	80.6	3.17	10.83	2.57	8.77	3.61	12.30	2.74	9.35	3.71	12.67	2.41	8.24
					31	87.8	3.21	10.94	2.69	9.19	3.64	12.43	2.88	9.82	3.75	12.80	2.63	8.96
	720	424	15	0.06	23	73.4	2.93	10.01	2.20	7.51	3.33	11.38	2.33	7.96	3.43	11.72	1.85	6.33
					24	75.2	2.96	10.11	2.37	8.09	3.37	11.49	2.46	8.39	3.47	11.84	2.05	6.98
					27	80.6	2.99	10.21	2.42	8.27	3.40	11.61	2.59	8.82	3.50	11.96	2.28	7.77
					31	87.8	3.02	10.32	2.54	8.67	3.44	11.72	2.71	9.26	3.54	12.08	2.48	8.45
	560	330	25	0.1	23	73.4	2.79	9.51	2.09	7.13	3.17	10.81	2.22	7.56	3.26	11.13	1.76	6.01
					24	75.2	2.82	9.61	2.25	7.69	3.20	10.92	2.34	7.97	3.30	11.24	1.94	6.63
					27	80.6	2.84	9.70	2.30	7.86	3.23	11.03	2.46	8.38	3.33	11.36	2.16	7.38
					31	87.8	2.87	9.80	2.41	8.23	3.26	11.14	2.58	8.80	3.36	11.47	2.35	8.03
	480	283	30	0.12	23	73.4	2.58	8.81	1.94	6.61	2.93	10.01	2.05	7.01	3.02	10.31	1.63	5.57
					24	75.2	2.61	8.90	2.09	7.12	2.96	10.11	2.16	7.38	3.05	10.42	1.80	6.15
					27	80.6	2.63	8.99	2.13	7.28	2.99	10.21	2.28	7.76	3.08	10.52	2.00	6.84
					31	87.8	2.66	9.08	2.24	7.63	3.02	10.32	2.39	8.15	3.11	10.63	2.18	7.44

Fan Speed	Air Flow Rate		ESP		Entering Air DBT		Outdoor Air Dry Bulb Temperature 110°F(43°C)											
							Indoor Air Wet Bulb Temperature °F(°C)											
							62°F(17°C)				67°F(19°C)				72°F(22°C)			
							Total Capacity		Sensible Capacity		Total Capacity		Sensible Capacity		Total Capacity		Sensible Capacity	
m ³ /hr	cfm	Pa	in.wg	°C	°F	kW	Mbh	kW	Mbh	kW	Mbh	kW	Mbh	kW	Mbh	kW	Mbh	
Low	860	506	0	0	23	73.4	2.80	9.55	2.10	7.16	3.18	10.85	2.23	7.60	3.28	11.18	1.77	6.04
					24	75.2	2.83	9.65	2.26	7.72	3.21	10.96	2.35	8.00	3.31	11.29	1.95	6.66
					27	80.6	2.86	9.74	2.31	7.89	3.25	11.07	2.47	8.42	3.34	11.41	2.17	7.41
					31	87.8	2.88	9.84	2.42	8.27	3.28	11.18	2.59	8.84	3.38	11.52	2.36	8.06
	720	424	15	0.06	23	73.4	2.64	9.01	1.98	6.76	3.00	10.24	2.10	7.17	3.09	10.55	1.67	5.69
					24	75.2	2.67	9.10	2.13	7.28	3.03	10.34	2.21	7.55	3.12	10.65	1.84	6.29
					27	80.6	2.69	9.19	2.18	7.45	3.06	10.45	2.33	7.94	3.15	10.76	2.05	6.99
					31	87.8	2.72	9.29	2.29	7.80	3.09	10.55	2.44	8.34	3.19	10.87	2.23	7.61
	560	330	25	0.1	23	73.4	2.51	8.56	1.88	6.42	2.85	9.73	2.00	6.81	2.94	10.02	1.59	5.41
					24	75.2	2.53	8.65	2.03	6.92	2.88	9.83	2.10	7.17	2.97	10.12	1.75	5.97
					27	80.6	2.56	8.73	2.07	7.07	2.91	9.92	2.21	7.54	3.00	10.22	1.95	6.64
					31	87.8	2.59	8.82	2.17	7.41	2.94	10.02	2.32	7.92	3.03	10.32	2.12	7.23
	480	283	30	0.12	23	73.4	2.32	7.93	1.74	5.95	2.64	9.01	1.85	6.31	2.72	9.28	1.47	5.01
					24	75.2	2.35	8.01	1.88	6.41	2.67	9.10	1.95	6.64	2.75	9.37	1.62	5.53
					27	80.6	2.37	8.09	1.92	6.55	2.69	9.19	2.05	6.99	2.78	9.47	1.80	6.15
					31	87.8	2.39	8.17	2.01	6.86	2.72	9.29	2.15	7.34	2.80	9.56	1.96	6.69

DC Inverter U-match Air Conditioners Technical Sales Guide

GFH18K3FI:

Fan Speed	Air Flow Rate		ESP		Entering Air DBT		Outdoor Air Dry Bulb Temperature 77°F(25°C)											
							Indoor Air Wet Bulb Temperature °F(°C)											
					62°F(17°C)				67°F(19°C)				72°F(22°C)					
	m ³ /hr	cfm	Pa	in.wg	°C	°F	Total Capacity		Sensible Capacity		Total Capacity		Sensible Capacity		Total Capacity		Sensible Capacity	
						kW	Mbh	kW	Mbh	kW	Mbh	kW	Mbh	kW	Mbh	kW	Mbh	
High	1180	695	0	0	23	73.4	5.13	17.50	3.85	13.12	5.83	19.88	4.08	13.92	6.00	20.48	3.24	11.06
					24	75.2	5.18	17.68	4.14	14.14	5.89	20.09	4.30	14.66	6.06	20.69	3.58	12.21
					27	80.6	5.23	17.86	4.24	14.46	5.95	20.29	4.52	15.42	6.12	20.90	3.98	13.58
					31	87.8	5.29	18.03	4.44	15.15	6.01	20.49	4.74	16.19	6.19	21.11	4.33	14.78
	1080	636	15	0.06	23	73.4	4.84	16.51	3.63	12.38	5.50	18.76	3.85	13.13	5.66	19.32	3.06	10.43
					24	75.2	4.89	16.68	3.91	13.34	5.55	18.95	4.05	13.83	5.72	19.52	3.38	11.52
					27	80.6	4.94	16.84	4.00	13.64	5.61	19.14	4.26	14.55	5.78	19.72	3.76	12.82
					31	87.8	4.99	17.01	4.19	14.29	5.67	19.33	4.48	15.27	5.84	19.91	4.09	13.94
	1000	589	25	0.1	23	73.4	4.60	15.68	3.45	11.76	5.22	17.82	3.66	12.47	5.38	18.36	2.90	9.91
					24	75.2	4.64	15.84	3.71	12.67	5.28	18.00	3.85	13.14	5.43	18.54	3.21	10.94
					27	80.6	4.69	16.00	3.80	12.96	5.33	18.18	4.05	13.82	5.49	18.73	3.57	12.17
					31	87.8	4.74	16.16	3.98	13.58	5.38	18.37	4.25	14.51	5.54	18.92	3.88	13.24
	960	565	30	0.12	23	73.4	4.26	14.53	3.19	10.89	4.84	16.51	3.39	11.56	4.98	17.00	2.69	9.18
					24	75.2	4.30	14.67	3.44	11.74	4.89	16.68	3.57	12.17	5.03	17.18	2.97	10.13
					27	80.6	4.34	14.82	3.52	12.01	4.94	16.84	3.75	12.80	5.08	17.35	3.31	11.28
					31	87.8	4.39	14.97	3.69	12.58	4.99	17.01	3.94	13.44	5.14	17.52	3.60	12.27

Fan Speed	Air Flow Rate		ESP		Entering Air DBT		Outdoor Air Dry Bulb Temperature 95°F(35°C)											
							Indoor Air Wet Bulb Temperature °F(°C)											
					62°F(17°C)				67°F(19°C)				72°F(22°C)					
	m ³ /hr	cfm	Pa	in.wg	°C	°F	Total Capacity		Sensible Capacity		Total Capacity		Sensible Capacity		Total Capacity		Sensible Capacity	
						kW	Mbh	kW	Mbh	kW	Mbh	kW	Mbh	kW	Mbh	kW	Mbh	
High	1180	695	0	0	23	73.4	4.66	15.91	3.50	11.93	5.30	18.08	3.71	12.65	5.46	18.62	2.95	10.05
					24	75.2	4.71	16.07	3.77	12.86	5.35	18.26	3.91	13.33	5.51	18.81	3.25	11.10
					27	80.6	4.76	16.23	3.85	13.15	5.41	18.45	4.11	14.02	5.57	19.00	3.62	12.35
					31	87.8	4.80	16.39	4.04	13.77	5.46	18.63	4.31	14.72	5.62	19.19	3.94	13.43
	1080	636	15	0.06	23	73.4	4.40	15.01	3.30	11.26	5.00	17.05	3.50	11.94	5.15	17.56	2.78	9.48
					24	75.2	4.44	15.16	3.55	12.13	5.05	17.23	3.69	12.58	5.20	17.74	3.07	10.47
					27	80.6	4.49	15.31	3.64	12.40	5.10	17.40	3.88	13.22	5.25	17.92	3.41	11.65
					31	87.8	4.53	15.47	3.81	12.99	5.15	17.58	4.07	13.88	5.31	18.10	3.71	12.67
	1000	589	25	0.1	23	73.4	4.18	14.26	3.13	10.69	4.75	16.20	3.32	11.34	4.89	16.69	2.64	9.01
					24	75.2	4.22	14.40	3.38	11.52	4.80	16.37	3.50	11.95	4.94	16.86	2.91	9.95
					27	80.6	4.26	14.55	3.45	11.78	4.85	16.53	3.68	12.56	4.99	17.03	3.24	11.07
					31	87.8	4.31	14.69	3.62	12.34	4.89	16.70	3.87	13.19	5.04	17.20	3.53	12.04
	960	565	30	0.12	23	73.4	3.87	13.21	2.90	9.90	4.40	15.01	3.08	10.50	4.53	15.46	2.45	8.35
					24	75.2	3.91	13.34	3.13	10.67	4.44	15.16	3.24	11.07	4.58	15.61	2.70	9.21
					27	80.6	3.95	13.48	3.20	10.92	4.49	15.31	3.41	11.64	4.62	15.77	3.00	10.25
					31	87.8	3.99	13.61	3.35	11.43	4.53	15.47	3.58	12.22	4.67	15.93	3.27	11.15

Fan Speed	Air Flow Rate		ESP		Entering Air DBT		Outdoor Air Dry Bulb Temperature 110°F(43°C)											
							Indoor Air Wet Bulb Temperature °F(°C)											
					62°F(17°C)				67°F(19°C)				72°F(22°C)					
	m ³ /hr	cfm	Pa	in.wg	°C	°F	Total Capacity		Sensible Capacity		Total Capacity		Sensible Capacity		Total Capacity		Sensible Capacity	
						kW	Mbh	kW	Mbh	kW	Mbh	kW	Mbh	kW	Mbh	kW	Mbh	
High	1180	695	0	0	23	73.4	4.20	14.32	3.15	10.74	4.77	16.27	3.34	11.39	4.91	16.76	2.65	9.05
					24	75.2	4.24	14.46	3.39	11.57	4.82	16.43	3.52	12.00	4.96	16.93	2.93	9.99
					27	80.6	4.28	14.61	3.47	11.83	4.87	16.60	3.70	12.62	5.01	17.10	3.26	11.11
					31	87.8	4.32	14.75	3.63	12.39	4.91	16.77	3.88	13.25	5.06	17.27	3.54	12.09
	1080	636	15	0.06	23	73.4	3.96	13.51	2.97	10.13	4.50	15.35	3.15	10.74	4.63	15.81	2.50	8.54
					24	75.2	4.00	13.64	3.20	10.92	4.54	15.50	3.32	11.32	4.68	15.97	2.76	9.42
					27	80.6	4.04	13.78	3.27	11.16	4.59	15.66	3.49	11.90	4.73	16.13	3.07	10.49
					31	87.8	4.08	13.92	3.43	11.69	4.64	15.82	3.66	12.50	4.77	16.29	3.34	11.40
	1000	589	25	0.1	23	73.4	3.76	12.83	2.82	9.62	4.27	14.58	2.99	10.21	4.40	15.02	2.38	8.11
					24	75.2	3.80	12.96	3.04	10.37	4.32	14.73	3.15	10.75	4.45	15.17	2.62	8.95
					27	80.6	3.84	13.09	3.11	10.61	4.36	14.88	3.31	11.31	4.49	15.32	2.92	9.96
					31	87.8	3.88	13.22	3.26	11.11	4.40	15.03	3.48	11.87	4.54	15.48	3.18	10.83
	960	565	30	0.12	23	73.4	3.48	11.89	2.61	8.91	3.96	13.51	2.77	9.45	4.08	13.91	2.20	7.51
					24	75.2	3.52	12.01	2.82	9.61	4.00	13.64	2.92	9.96	4.12	14.05	2.43	8.29
					27	80.6	3.55	12.13	2.88	9.82	4.04	13.78	3.07	10.47	4.16	14.20	2.70	9.23
					31	87.8	3.59	12.25	3.02	10.29	4.08	13.92	3.22	11.00	4.20	14.34	2.94	10.04

Fan Speed	Air Flow Rate		ESP		Entering Air DBT		Outdoor Air Dry Bulb Temperature 77°F(25°C)											
							Indoor Air Wet Bulb Temperature °F(°C)											
					62°F(17°C)				67°F(19°C)				72°F(22°C)					
	m ³ /hr	cfm	Pa	in.wg	°C	°F	Total Capacity		Sensible Capacity		Total Capacity		Sensible Capacity		Total Capacity		Sensible Capacity	
						kW	Mbh	kW	Mbh	kW	Mbh	kW	Mbh	kW	Mbh	kW	Mbh	
Medium	1080	636	0	0	23	73.4	4.87	16.62	3.65	12.47	5.54	18.89	3.88	13.22	5.70	19.46	3.08	10.51
					24	75.2	4.92	16.79	3.94	13.43	5.59	19.08	4.08	13.93	5.76	19.66	3.40	11.60
					27	80.6	4.97	16.96	4.03	13.74	5.65	19.28	4.29	14.65	5.82	19.85	3.78	12.90
					31	87.8	5.02	17.13	4.22	14.39	5.71	19.47	4.51	15.38	5.88	20.05	4.11	14.04
	980	577	15	0.06	23	73.4	4.60	15.68	3.45	11.76	5.22	17.82	3.66	12.47	5.38	18.36	2.90	9.91
					24	75.2	4.64	15.84	3.71	12.67	5.28	18.00	3.85	13.14	5.43	18.54	3.21	10.94
					27	80.6	4.69	16.00	3.80	12.96	5.33	18.18	4.05	13.82	5.49	18.73	3.57	12.17
					31	87.8	4.74	16.16	3.98	13.58	5.38	18.37	4.25	14.51	5.54	18.92	3.88	13.24
	900	530	25	0.1	23	73.4	4.37	14.90	3.27	11.17	4.96	16.93	3.47	11.85	5.11	17.44	2.76	9.42
					24	75.2	4.41	15.05	3.53	12.04	5.01	17.10	3.66	12.48	5.16	17.62	3.05	10.39
					27	80.6	4.46	15.20	3.61	12.31	5.06	17.28	3.85	13.13	5.21	17.79	3.39	11.57
					31	87.8	4.50	15.35	3.78	12.90	5.11	17.45	4.04	13.78	5.27	17.97	3.69	12.58
	860	506	30	0.12	23	73.4	4.04	13.80	3.03	10.35	4.60	15.68	3.22	10.98	4.73	16.15	2.56	8.72
					24	75.2	4.09	13.94	3.27	11.15	4.64	15.84	3.39	11.56	4.78	16.32	2.82	9.63
					27	80.6	4.13	14.08	3.34	11.41	4.69	16.00	3.56	12.16	4.83	16.48	3.14	10.71
					31	87.8	4.17	14.22	3.50	11.95	4.74	16.16	3.74	12.77	4.88	16.65	3.42	11.65

DC Inverter U-match Air Conditioners Technical Sales Guide

Fan Speed	Air Flow Rate		ESP		Entering Air DBT		Outdoor Air Dry Bulb Temperature 95°F(35°C)											
							Indoor Air Wet Bulb Temperature °F(°C)											
	62°F(17°C)		67°F(19°C)		72°F(22°C)													
	Total Capacity	Sensible Capacity	Total Capacity	Sensible Capacity	Total Capacity	Sensible Capacity												
m ³ /hr	cfm	Pa	in.wg	°C	°F	kW	Mbh	kW	Mbh	kW	Mbh	kW	Mbh	kW	Mbh	kW	Mbh	
Medium	1080	636	0	0	23	73.4	4.43	15.11	3.32	11.33	5.03	17.17	3.52	12.02	5.18	17.69	2.80	9.55
					24	75.2	4.47	15.27	3.58	12.21	5.08	17.35	3.71	12.66	5.24	17.87	3.09	10.54
					27	80.6	4.52	15.42	3.66	12.49	5.14	17.52	3.90	13.32	5.29	18.05	3.44	11.73
					31	87.8	4.56	15.57	3.83	13.08	5.19	17.70	4.10	13.98	5.34	18.23	3.74	12.76
	980	577	15	0.06	23	73.4	4.18	14.26	3.13	10.69	4.75	16.20	3.32	11.34	4.89	16.69	2.64	9.01
					24	75.2	4.22	14.40	3.38	11.52	4.80	16.37	3.50	11.95	4.94	16.86	2.91	9.95
					27	80.6	4.26	14.55	3.45	11.78	4.85	16.53	3.68	12.56	4.99	17.03	3.24	11.07
					31	87.8	4.31	14.69	3.62	12.34	4.89	16.70	3.87	13.19	5.04	17.20	3.53	12.04
	900	530	25	0.1	23	73.4	3.97	13.54	2.98	10.16	4.51	15.39	3.16	10.77	4.65	15.85	2.51	8.56
					24	75.2	4.01	13.68	3.21	10.95	4.56	15.55	3.33	11.35	4.69	16.01	2.77	9.45
					27	80.6	4.05	13.82	3.28	11.19	4.60	15.70	3.50	11.94	4.74	16.18	3.08	10.51
					31	87.8	4.09	13.96	3.44	11.72	4.65	15.86	3.67	12.53	4.79	16.34	3.35	11.44
	860	506	30	0.12	23	73.4	3.68	12.55	2.76	9.41	4.18	14.26	2.92	9.98	4.30	14.68	2.32	7.93
					24	75.2	3.71	12.67	2.97	10.14	4.22	14.40	3.08	10.51	4.35	14.83	2.57	8.75
					27	80.6	3.75	12.80	3.04	10.37	4.26	14.55	3.24	11.06	4.39	14.98	2.85	9.74
					31	87.8	3.79	12.93	3.18	10.86	4.31	14.69	3.40	11.61	4.44	15.13	3.10	10.59

Fan Speed	Air Flow Rate		ESP		Entering Air DBT		Outdoor Air Dry Bulb Temperature 110°F(43°C)											
							Indoor Air Wet Bulb Temperature °F(°C)											
	62°F(17°C)		67°F(19°C)		72°F(22°C)													
	Total Capacity	Sensible Capacity	Total Capacity	Sensible Capacity	Total Capacity	Sensible Capacity												
m ³ /hr	cfm	Pa	in.wg	°C	°F	kW	Mbh	kW	Mbh	kW	Mbh	kW	Mbh	kW	Mbh	kW	Mbh	
Medium	1080	636	0	0	23	73.4	3.99	13.60	2.99	10.20	4.53	15.46	3.17	10.82	4.67	15.92	2.52	8.60
					24	75.2	4.03	13.74	3.22	10.99	4.58	15.61	3.34	11.40	4.71	16.08	2.78	9.49
					27	80.6	4.07	13.88	3.29	11.24	4.62	15.77	3.51	11.99	4.76	16.24	3.09	10.56
					31	87.8	4.11	14.02	3.45	11.77	4.67	15.93	3.69	12.58	4.81	16.41	3.37	11.48
	980	577	15	0.06	23	73.4	3.76	12.83	2.82	9.62	4.27	14.58	2.99	10.21	4.40	15.02	2.38	8.11
					24	75.2	3.80	12.96	3.04	10.37	4.32	14.73	3.15	10.75	4.45	15.17	2.62	8.95
					27	80.6	3.84	13.09	3.11	10.61	4.36	14.88	3.31	11.31	4.49	15.32	2.92	9.96
					31	87.8	3.88	13.22	3.26	11.11	4.40	15.03	3.48	11.87	4.54	15.48	3.18	10.83
	900	530	25	0.1	23	73.4	3.57	12.19	2.68	9.14	4.06	13.85	2.84	9.70	4.18	14.27	2.26	7.70
					24	75.2	3.61	12.31	2.89	9.85	4.10	13.99	2.99	10.21	4.22	14.41	2.49	8.50
					27	80.6	3.65	12.44	2.95	10.07	4.14	14.13	3.15	10.74	4.27	14.56	2.77	9.46
					31	87.8	3.68	12.56	3.09	10.55	4.18	14.28	3.31	11.28	4.31	14.70	3.02	10.29
	860	506	30	0.12	23	73.4	3.31	11.29	2.48	8.47	3.76	12.83	2.63	8.98	3.87	13.22	2.09	7.14
					24	75.2	3.34	11.41	2.67	9.13	3.80	12.96	2.77	9.46	3.91	13.35	2.31	7.88
					27	80.6	3.38	11.52	2.74	9.33	3.84	13.09	2.92	9.95	3.95	13.49	2.57	8.77
					31	87.8	3.41	11.64	2.86	9.77	3.88	13.22	3.06	10.45	3.99	13.62	2.79	9.53

Fan Speed	Air Flow Rate		ESP		Entering Air DBT		Outdoor Air Dry Bulb Temperature 77°F(25°C)											
							Indoor Air Wet Bulb Temperature °F(°C)											
							62°F(17°C)			67°F(19°C)			72°F(22°C)					
	m ³ /hr	cfm	Pa	in.wg	°C	°F	Total Capacity		Sensible Capacity		Total Capacity		Sensible Capacity		Total Capacity		Sensible Capacity	
						kW	Mbh	kW	Mbh	kW	Mbh	kW	Mbh	kW	Mbh	kW	Mbh	
Low	900	530	0	0	23	73.4	4.62	15.75	3.46	11.81	5.24	17.90	3.67	12.53	5.40	18.43	2.92	9.95
					24	75.2	4.66	15.91	3.73	12.73	5.30	18.08	3.87	13.20	5.46	18.62	3.22	10.99
					27	80.6	4.71	16.07	3.81	13.02	5.35	18.26	4.07	13.88	5.51	18.81	3.58	12.23
					31	87.8	4.76	16.23	4.00	13.63	5.41	18.44	4.27	14.57	5.57	19.00	3.90	13.30
	780	459	15	0.06	23	73.4	4.35	14.86	3.27	11.14	4.95	16.88	3.46	11.82	5.10	17.39	2.75	9.39
					24	75.2	4.40	15.01	3.52	12.01	5.00	17.05	3.65	12.45	5.15	17.57	3.04	10.36
					27	80.6	4.44	15.16	3.60	12.28	5.05	17.23	3.84	13.09	5.20	17.74	3.38	11.53
					31	87.8	4.49	15.31	3.77	12.86	5.10	17.40	4.03	13.75	5.25	17.92	3.68	12.55
	700	412	25	0.1	23	73.4	4.14	14.11	3.10	10.59	4.70	16.04	3.29	11.23	4.84	16.52	2.61	8.92
					24	75.2	4.18	14.26	3.34	11.41	4.75	16.20	3.47	11.83	4.89	16.69	2.89	9.85
					27	80.6	4.22	14.40	3.42	11.67	4.80	16.37	3.65	12.44	4.94	16.86	3.21	10.96
					31	87.8	4.26	14.55	3.58	12.22	4.84	16.53	3.83	13.06	4.99	17.03	3.49	11.92
	650	383	30	0.12	23	73.4	3.83	13.07	2.87	9.81	4.35	14.86	3.05	10.40	4.48	15.30	2.42	8.26
					24	75.2	3.87	13.21	3.10	10.57	4.40	15.01	3.21	10.96	4.53	15.46	2.67	9.12
					27	80.6	3.91	13.34	3.17	10.81	4.44	15.16	3.38	11.52	4.58	15.61	2.97	10.15
					31	87.8	3.95	13.47	3.32	11.32	4.49	15.31	3.55	12.10	4.62	15.77	3.24	11.04

Fan Speed	Air Flow Rate		ESP		Entering Air DBT		Outdoor Air Dry Bulb Temperature 95°F(35°C)											
							Indoor Air Wet Bulb Temperature °F(°C)											
							62°F(17°C)			67°F(19°C)			72°F(22°C)					
	m ³ /hr	cfm	Pa	in.wg	°C	°F	Total Capacity		Sensible Capacity		Total Capacity		Sensible Capacity		Total Capacity		Sensible Capacity	
						kW	Mbh	kW	Mbh	kW	Mbh	kW	Mbh	kW	Mbh	kW	Mbh	
Low	900	530	0	0	23	73.4	4.20	14.32	3.15	10.74	4.77	16.27	3.34	11.39	4.91	16.76	2.65	9.05
					24	75.2	4.24	14.46	3.39	11.57	4.82	16.43	3.52	12.00	4.96	16.93	2.93	9.99
					27	80.6	4.28	14.61	3.47	11.83	4.87	16.60	3.70	12.62	5.01	17.10	3.26	11.11
					31	87.8	4.32	14.75	3.63	12.39	4.91	16.77	3.88	13.25	5.06	17.27	3.54	12.09
	780	459	15	0.06	23	73.4	3.96	13.51	2.97	10.13	4.50	15.35	3.15	10.74	4.63	15.81	2.50	8.54
					24	75.2	4.00	13.64	3.20	10.92	4.54	15.50	3.32	11.32	4.68	15.97	2.76	9.42
					27	80.6	4.04	13.78	3.27	11.16	4.59	15.66	3.49	11.90	4.73	16.13	3.07	10.49
					31	87.8	4.08	13.92	3.43	11.69	4.64	15.82	3.66	12.50	4.77	16.29	3.34	11.40
	700	412	25	0.1	23	73.4	3.76	12.83	2.82	9.62	4.27	14.58	2.99	10.21	4.40	15.02	2.38	8.11
					24	75.2	3.80	12.96	3.04	10.37	4.32	14.73	3.15	10.75	4.45	15.17	2.62	8.95
					27	80.6	3.84	13.09	3.11	10.61	4.36	14.88	3.31	11.31	4.49	15.32	2.92	9.96
					31	87.8	3.88	13.22	3.26	11.11	4.40	15.03	3.48	11.87	4.54	15.48	3.18	10.83
	650	383	30	0.12	23	73.4	3.48	11.89	2.61	8.91	3.96	13.51	2.77	9.45	4.08	13.91	2.20	7.51
					24	75.2	3.52	12.01	2.82	9.61	4.00	13.64	2.92	9.96	4.12	14.05	2.43	8.29
					27	80.6	3.55	12.13	2.88	9.82	4.04	13.78	3.07	10.47	4.16	14.20	2.70	9.23
					31	87.8	3.59	12.25	3.02	10.29	4.08	13.92	3.22	11.00	4.20	14.34	2.94	10.04

DC Inverter U-match Air Conditioners Technical Sales Guide

Fan Speed	Air Flow Rate		ESP		Entering Air DBT		Outdoor Air Dry Bulb Temperature 110°F(43°C)											
							Indoor Air Wet Bulb Temperature °F(°C)											
					62°F(17°C)				67°F(19°C)				72°F(22°C)					
	m ³ /hr	cfm	Pa	in.wg	°C	°F	Total Capacity		Sensible Capacity		Total Capacity		Sensible Capacity		Total Capacity		Sensible Capacity	
						kW	Mbh	kW	Mbh	kW	Mbh	kW	Mbh	kW	Mbh	kW	Mbh	
Low	900	530	0	0	23	73.4	3.78	12.88	2.83	9.66	4.29	14.64	3.00	10.25	4.42	15.08	2.39	8.14
					24	75.2	3.81	13.02	3.05	10.41	4.34	14.79	3.16	10.80	4.47	15.24	2.63	8.99
					27	80.6	3.85	13.15	3.12	10.65	4.38	14.94	3.33	11.35	4.51	15.39	2.93	10.00
					31	87.8	3.89	13.28	3.27	11.15	4.42	15.09	3.49	11.92	4.56	15.54	3.19	10.88
	780	459	15	0.06	23	73.4	3.56	12.16	2.67	9.12	4.05	13.81	2.83	9.67	4.17	14.23	2.25	7.68
					24	75.2	3.60	12.28	2.88	9.82	4.09	13.95	2.99	10.19	4.21	14.37	2.49	8.48
					27	80.6	3.64	12.40	2.94	10.05	4.13	14.09	3.14	10.71	4.25	14.52	2.77	9.44
					31	87.8	3.67	12.53	3.08	10.52	4.17	14.24	3.30	11.25	4.30	14.66	3.01	10.26
	700	412	25	0.1	23	73.4	3.38	11.55	2.54	8.66	3.85	13.12	2.69	9.19	3.96	13.52	2.14	7.30
					24	75.2	3.42	11.67	2.74	9.33	3.89	13.26	2.84	9.68	4.00	13.65	2.36	8.06
					27	80.6	3.45	11.78	2.80	9.54	3.92	13.39	2.98	10.18	4.04	13.79	2.63	8.96
					31	87.8	3.49	11.90	2.93	10.00	3.96	13.52	3.13	10.68	4.08	13.93	2.86	9.75
	650	383	30	0.12	23	73.4	3.14	10.70	2.35	8.02	3.56	12.16	2.49	8.51	3.67	12.52	1.98	6.76
					24	75.2	3.17	10.81	2.53	8.64	3.60	12.28	2.63	8.96	3.71	12.65	2.19	7.46
					27	80.6	3.20	10.92	2.59	8.84	3.64	12.40	2.76	9.43	3.74	12.78	2.43	8.30
					31	87.8	3.23	11.02	2.71	9.26	3.67	12.53	2.90	9.90	3.78	12.90	2.65	9.03

GFH24K3FI:

Fan Speed	Air Flow Rate		ESP		Entering Air DBT		Outdoor Air Dry Bulb Temperature 77°F(25°C)											
							Indoor Air Wet Bulb Temperature °F(°C)											
					62°F(17°C)				67°F(19°C)				72°F(22°C)					
	m ³ /hr	cfm	Pa	in.wg	°C	°F	Total Capacity		Sensible Capacity		Total Capacity		Sensible Capacity		Total Capacity		Sensible Capacity	
						kW	Mbh	kW	Mbh	kW	Mbh	kW	Mbh	kW	Mbh	kW	Mbh	
High	1760	1036	0	0	23	73.4	7.50	25.60	5.63	19.20	8.52	29.09	5.97	20.36	8.78	29.96	4.74	16.18
					24	75.2	7.58	25.86	6.06	20.68	8.61	29.38	6.29	21.45	8.87	30.26	5.23	17.86
					27	80.6	7.65	26.12	6.20	21.16	8.70	29.68	6.61	22.56	8.96	30.57	5.82	19.87
					31	87.8	7.73	26.38	6.49	22.16	8.79	29.98	6.94	23.68	9.05	30.87	6.33	21.61
	1620	954	15	0.06	23	73.4	7.08	24.15	5.31	18.11	8.04	27.44	5.63	19.21	8.28	28.26	4.47	15.26
					24	75.2	7.15	24.39	5.72	19.51	8.12	27.72	5.93	20.23	8.37	28.55	4.94	16.84
					27	80.6	7.22	24.64	5.85	19.96	8.21	28.00	6.24	21.28	8.45	28.84	5.49	18.75
					31	87.8	7.29	24.89	6.13	20.90	8.29	28.28	6.55	22.34	8.54	29.13	5.98	20.39
	1400	824	25	0.1	23	73.4	6.72	22.94	5.04	17.20	7.64	26.07	5.35	18.25	7.87	26.85	4.25	14.50
					24	75.2	6.79	23.17	5.43	18.54	7.72	26.33	5.63	19.22	7.95	27.12	4.69	16.00
					27	80.6	6.86	23.41	5.56	18.96	7.80	26.60	5.92	20.22	8.03	27.40	5.22	17.81
					31	87.8	6.93	23.64	5.82	19.86	7.87	26.86	6.22	21.22	8.11	27.67	5.68	19.37
	1300	765	50	0.2	23	73.4	6.23	21.25	4.67	15.94	7.08	24.15	4.95	16.90	7.29	24.87	3.94	13.43
					24	75.2	6.29	21.47	5.03	17.17	7.15	24.39	5.22	17.81	7.36	25.12	4.34	14.82
					27	80.6	6.35	21.68	5.15	17.56	7.22	24.64	5.49	18.73	7.44	25.38	4.83	16.50
					31	87.8	6.42	21.90	5.39	18.40	7.29	24.89	5.76	19.66	7.51	25.63	5.26	17.94

DC Inverter U-match Air Conditioners Technical Sales Guide

Fan Speed	Air Flow Rate		ESP		Entering Air DBT		Outdoor Air Dry Bulb Temperature 77°F(25°C)												
							Indoor Air Wet Bulb Temperature °F(°C)												
					62°F(17°C)			67°F(19°C)			72°F(22°C)								
	m ³ /hr	cfm	Pa	in.wg	°C	°F	Total Capacity		Sensible Capacity		Total Capacity		Sensible Capacity		Total Capacity		Sensible Capacity		
						kW	Mbh	kW	Mbh	kW	Mbh	kW	Mbh	kW	Mbh	kW	Mbh	kW	Mbh
Medium	1620	954	0	0	23	73.4	7.13	24.32	5.34	18.24	8.10	27.63	5.67	19.34	8.34	28.46	4.50	15.37	
					24	75.2	7.20	24.56	5.76	19.65	8.18	27.91	5.97	20.38	8.43	28.75	4.97	16.96	
					27	80.6	7.27	24.81	5.89	20.10	8.26	28.19	6.28	21.43	8.51	29.04	5.53	18.88	
					31	87.8	7.34	25.06	6.17	21.05	8.35	28.48	6.59	22.50	8.60	29.33	6.02	20.53	
	1500	883	15	0.06	23	73.4	6.72	22.94	5.04	17.20	7.64	26.07	5.35	18.25	7.87	26.85	4.25	14.50	
					24	75.2	6.79	23.17	5.43	18.54	7.72	26.33	5.63	19.22	7.95	27.12	4.69	16.00	
					27	80.6	6.86	23.41	5.56	18.96	7.80	26.60	5.92	20.22	8.03	27.40	5.22	17.81	
					31	87.8	6.93	23.64	5.82	19.86	7.87	26.86	6.22	21.22	8.11	27.67	5.68	19.37	
	1360	800	25	0.1	23	73.4	6.39	21.79	4.79	16.34	7.26	24.76	5.08	17.33	7.48	25.51	4.04	13.77	
					24	75.2	6.45	22.01	5.16	17.61	7.33	25.02	5.35	18.26	7.55	25.77	4.46	15.20	
					27	80.6	6.52	22.24	5.28	18.01	7.41	25.27	5.63	19.20	7.63	26.03	4.96	16.92	
					31	87.8	6.58	22.46	5.53	18.87	7.48	25.52	5.91	20.16	7.70	26.29	5.39	18.40	
	1140	671	50	0.2	23	73.4	5.92	20.19	4.44	15.14	6.72	22.94	4.71	16.06	6.92	23.63	3.74	12.76	
					24	75.2	5.98	20.39	4.78	16.31	6.79	23.17	4.96	16.92	7.00	23.87	4.13	14.08	
					27	80.6	6.04	20.60	4.89	16.68	6.86	23.41	5.21	17.79	7.07	24.11	4.59	15.67	
					31	87.8	6.10	20.80	5.12	17.48	6.93	23.64	5.47	18.68	7.14	24.35	5.00	17.05	

Fan Speed	Air Flow Rate		ESP		Entering Air DBT		Outdoor Air Dry Bulb Temperature 95°F(35°C)												
							Indoor Air Wet Bulb Temperature °F(°C)												
					62°F(17°C)			67°F(19°C)			72°F(22°C)								
	m ³ /hr	cfm	Pa	in.wg	°C	°F	Total Capacity		Sensible Capacity		Total Capacity		Sensible Capacity		Total Capacity		Sensible Capacity		
						kW	Mbh	kW	Mbh	kW	Mbh	kW	Mbh	kW	Mbh	kW	Mbh	kW	Mbh
Medium	1620	954	0	0	23	73.4	6.48	22.10	4.86	16.58	7.36	25.12	5.15	17.58	7.58	25.87	4.09	13.97	
					24	75.2	6.54	22.33	5.24	17.86	7.44	25.38	5.43	18.52	7.66	26.14	4.52	15.42	
					27	80.6	6.61	22.56	5.35	18.27	7.51	25.63	5.71	19.48	7.74	26.40	5.03	17.16	
					31	87.8	6.68	22.78	5.61	19.14	7.59	25.89	5.99	20.45	7.81	26.66	5.47	18.67	
	1500	883	15	0.06	23	73.4	6.11	20.85	4.58	15.64	6.95	23.70	4.86	16.59	7.15	24.41	3.86	13.18	
					24	75.2	6.17	21.07	4.94	16.85	7.02	23.94	5.12	17.48	7.23	24.66	4.26	14.55	
					27	80.6	6.24	21.28	5.05	17.24	7.09	24.18	5.39	18.38	7.30	24.91	4.74	16.19	
					31	87.8	6.30	21.49	5.29	18.05	7.16	24.42	5.65	19.29	7.37	25.16	5.16	17.61	
	1360	800	25	0.1	23	73.4	5.81	19.81	4.35	14.86	6.60	22.51	4.62	15.76	6.80	23.19	3.67	12.52	
					24	75.2	5.87	20.01	4.69	16.01	6.67	22.74	4.87	16.60	6.87	23.42	4.05	13.82	
					27	80.6	5.92	20.22	4.80	16.37	6.73	22.97	5.12	17.46	6.93	23.66	4.51	15.38	
					31	87.8	5.98	20.42	5.03	17.15	6.80	23.20	5.37	18.33	7.00	23.90	4.90	16.73	
	1140	671	50	0.2	23	73.4	5.38	18.35	4.03	13.76	6.11	20.85	4.28	14.60	6.30	21.48	3.40	11.60	
					24	75.2	5.43	18.54	4.35	14.83	6.17	21.07	4.51	15.38	6.36	21.70	3.75	12.80	
					27	80.6	5.49	18.73	4.45	15.17	6.24	21.28	4.74	16.17	6.42	21.92	4.18	14.25	
					31	87.8	5.54	18.91	4.66	15.89	6.30	21.49	4.98	16.98	6.49	22.14	4.54	15.50	

Fan Speed	Air Flow Rate		ESP		Entering Air DBT		Outdoor Air Dry Bulb Temperature 110°F(43°C)											
							Indoor Air Wet Bulb Temperature °F(°C)											
							62°F(17°C)				67°F(19°C)				72°F(22°C)			
							Total Capacity		Sensible Capacity		Total Capacity		Sensible Capacity		Total Capacity		Sensible Capacity	
m ³ /hr	cfm	Pa	in.wg	°C	°F	kW	Mbh	kW	Mbh	kW	Mbh	kW	Mbh	kW	Mbh	kW	Mbh	
Medium	1620	954	0	0	23	73.4	5.83	19.89	4.37	14.92	6.63	22.61	4.64	15.83	6.82	23.29	3.69	12.57
					24	75.2	5.89	20.10	4.71	16.08	6.69	22.84	4.89	16.67	6.89	23.52	4.07	13.88
					27	80.6	5.95	20.30	4.82	16.44	6.76	23.07	5.14	17.53	6.96	23.76	4.53	15.44
					31	87.8	6.01	20.50	5.05	17.22	6.83	23.30	5.39	18.41	7.03	24.00	4.92	16.80
	1500	883	15	0.06	23	73.4	5.50	18.77	4.13	14.08	6.25	21.33	4.38	14.93	6.44	21.97	3.48	11.86
					24	75.2	5.56	18.96	4.45	15.17	6.31	21.55	4.61	15.73	6.50	22.19	3.84	13.09
					27	80.6	5.61	19.15	4.55	15.51	6.38	21.76	4.85	16.54	6.57	22.42	4.27	14.57
					31	87.8	5.67	19.34	4.76	16.25	6.44	21.98	5.09	17.36	6.64	22.64	4.64	15.85
	1360	800	25	0.1	23	73.4	5.23	17.83	3.92	13.37	5.94	20.26	4.16	14.18	6.12	20.87	3.30	11.27
					24	75.2	5.28	18.01	4.22	14.41	6.00	20.47	4.38	14.94	6.18	21.08	3.65	12.44
					27	80.6	5.33	18.19	4.32	14.74	6.06	20.67	4.61	15.71	6.24	21.29	4.06	13.84
					31	87.8	5.39	18.38	4.52	15.44	6.12	20.88	4.83	16.50	6.30	21.51	4.41	15.06
	1140	671	50	0.2	23	73.4	4.84	16.52	3.63	12.39	5.50	18.77	3.85	13.14	5.67	19.33	3.06	10.44
					24	75.2	4.89	16.68	3.91	13.35	5.56	18.96	4.06	13.84	5.72	19.53	3.38	11.52
					27	80.6	4.94	16.85	4.00	13.65	5.61	19.15	4.27	14.55	5.78	19.73	3.76	12.82
					31	87.8	4.99	17.02	4.19	14.30	5.67	19.34	4.48	15.28	5.84	19.92	4.09	13.95

Fan Speed	Air Flow Rate		ESP		Entering Air DBT		Outdoor Air Dry Bulb Temperature 77°F(25°C)											
							Indoor Air Wet Bulb Temperature °F(°C)											
							62°F(17°C)				67°F(19°C)				72°F(22°C)			
							Total Capacity		Sensible Capacity		Total Capacity		Sensible Capacity		Total Capacity		Sensible Capacity	
m ³ /hr	cfm	Pa	in.wg	°C	°F	kW	Mbh	kW	Mbh	kW	Mbh	kW	Mbh	kW	Mbh	kW	Mbh	
Low	1520	895	0	0	23	73.4	6.75	23.04	5.06	17.28	7.67	26.18	5.37	18.32	7.90	26.96	4.27	14.56
					24	75.2	6.82	23.27	5.46	18.62	7.75	26.44	5.66	19.30	7.98	27.24	4.71	16.07
					27	80.6	6.89	23.51	5.58	19.04	7.83	26.71	5.95	20.30	8.06	27.51	5.24	17.88
					31	87.8	6.96	23.74	5.84	19.94	7.91	26.98	6.25	21.31	8.14	27.79	5.70	19.45
	1400	824	15	0.06	23	73.4	6.37	21.73	4.78	16.30	7.24	24.70	5.07	17.29	7.45	25.44	4.03	13.74
					24	75.2	6.43	21.95	5.15	17.56	7.31	24.95	5.34	18.21	7.53	25.70	4.44	15.16
					27	80.6	6.50	22.18	5.26	17.96	7.39	25.20	5.61	19.15	7.61	25.95	4.94	16.87
					31	87.8	6.56	22.40	5.51	18.81	7.46	25.45	5.89	20.11	7.68	26.21	5.38	18.35
	1300	765	25	0.1	23	73.4	6.05	20.65	4.54	15.48	6.88	23.46	4.81	16.42	7.08	24.16	3.82	13.05
					24	75.2	6.11	20.86	4.89	16.68	6.95	23.70	5.07	17.30	7.15	24.41	4.22	14.40
					27	80.6	6.17	21.07	5.00	17.06	7.02	23.94	5.33	18.19	7.23	24.66	4.70	16.03
					31	87.8	6.24	21.28	5.24	17.87	7.09	24.18	5.60	19.10	7.30	24.90	5.11	17.43
	1020	600	50	0.2	23	73.4	5.60	19.12	4.20	14.34	6.37	21.73	4.46	15.21	6.56	22.38	3.54	12.09
					24	75.2	5.66	19.32	4.53	15.46	6.43	21.95	4.70	16.03	6.63	22.61	3.91	13.34
					27	80.6	5.72	19.51	4.63	15.81	6.50	22.18	4.94	16.85	6.69	22.84	4.35	14.85
					31	87.8	5.78	19.71	4.85	16.56	6.56	22.40	5.19	17.69	6.76	23.07	4.73	16.15

DC Inverter U-match Air Conditioners Technical Sales Guide

Fan Speed	Air Flow Rate		ESP		Entering Air DBT		Outdoor Air Dry Bulb Temperature 95°F(35°C)											
							Indoor Air Wet Bulb Temperature °F(°C)											
					62°F(17°C)				67°F(19°C)				72°F(22°C)					
	m ³ /hr	cfm	Pa	in.wg	°C	°F	Total Capacity		Sensible Capacity		Total Capacity		Sensible Capacity		Total Capacity		Sensible Capacity	
						kW	Mbh	kW	Mbh	kW	Mbh	kW	Mbh	kW	Mbh	kW	Mbh	
Low	1520	895	0	0	23	73.4	6.14	20.94	4.60	15.71	6.97	23.80	4.88	16.66	7.18	24.51	3.88	13.24
					24	75.2	6.20	21.16	4.96	16.92	7.05	24.04	5.14	17.55	7.26	24.76	4.28	14.61
					27	80.6	6.26	21.37	5.07	17.31	7.12	24.28	5.41	18.45	7.33	25.01	4.76	16.26
					31	87.8	6.33	21.58	5.31	18.13	7.19	24.53	5.68	19.38	7.40	25.26	5.18	17.68
	1400	824	15	0.06	23	73.4	5.79	19.76	4.34	14.82	6.58	22.45	4.61	15.72	6.78	23.12	3.66	12.49
					24	75.2	5.85	19.96	4.68	15.97	6.65	22.68	4.85	16.56	6.85	23.36	4.04	13.78
					27	80.6	5.91	20.16	4.79	16.33	6.71	22.91	5.10	17.41	6.92	23.60	4.50	15.34
					31	87.8	5.97	20.36	5.01	17.10	6.78	23.14	5.36	18.28	6.98	23.83	4.89	16.68
	1300	765	25	0.1	23	73.4	5.50	18.77	4.13	14.08	6.25	21.33	4.38	14.93	6.44	21.97	3.48	11.86
					24	75.2	5.56	18.96	4.45	15.17	6.31	21.55	4.61	15.73	6.50	22.19	3.84	13.09
					27	80.6	5.61	19.15	4.55	15.51	6.38	21.76	4.85	16.54	6.57	22.42	4.27	14.57
					31	87.8	5.67	19.34	4.76	16.25	6.44	21.98	5.09	17.36	6.64	22.64	4.64	15.85
	1020	600	50	0.2	23	73.4	5.10	17.39	3.82	13.04	5.79	19.76	4.05	13.83	5.96	20.35	3.22	10.99
					24	75.2	5.15	17.56	4.12	14.05	5.85	19.96	4.27	14.57	6.02	20.56	3.55	12.13
					27	80.6	5.20	17.74	4.21	14.37	5.91	20.16	4.49	15.32	6.09	20.76	3.96	13.50
					31	87.8	5.25	17.92	4.41	15.05	5.97	20.36	4.71	16.09	6.15	20.97	4.30	14.68

Fan Speed	Air Flow Rate		ESP		Entering Air DBT		Outdoor Air Dry Bulb Temperature 110°F(43°C)											
							Indoor Air Wet Bulb Temperature °F(°C)											
					62°F(17°C)				67°F(19°C)				72°F(22°C)					
	m ³ /hr	cfm	Pa	in.wg	°C	°F	Total Capacity		Sensible Capacity		Total Capacity		Sensible Capacity		Total Capacity		Sensible Capacity	
						kW	Mbh	kW	Mbh	kW	Mbh	kW	Mbh	kW	Mbh	kW	Mbh	
Low	1520	895	0	0	23	73.4	5.52	18.85	4.14	14.14	6.28	21.42	4.39	14.99	6.47	22.06	3.49	11.91
					24	75.2	5.58	19.04	4.46	15.23	6.34	21.64	4.63	15.79	6.53	22.28	3.85	13.15
					27	80.6	5.64	19.23	4.57	15.58	6.41	21.85	4.87	16.61	6.60	22.51	4.29	14.63
					31	87.8	5.69	19.42	4.78	16.32	6.47	22.07	5.11	17.44	6.66	22.74	4.66	15.91
	1400	824	15	0.06	23	73.4	5.21	17.78	3.91	13.34	5.92	20.21	4.15	14.14	6.10	20.81	3.29	11.24
					24	75.2	5.26	17.96	4.21	14.37	5.98	20.41	4.37	14.90	6.16	21.02	3.64	12.40
					27	80.6	5.32	18.14	4.31	14.70	6.04	20.62	4.59	15.67	6.22	21.24	4.05	13.80
					31	87.8	5.37	18.32	4.51	15.39	6.10	20.82	4.82	16.45	6.29	21.45	4.40	15.01
	1300	765	25	0.1	23	73.4	4.95	16.89	3.71	12.67	5.63	19.19	3.94	13.44	5.79	19.77	3.13	10.68
					24	75.2	5.00	17.06	4.00	13.65	5.68	19.39	4.15	14.16	5.85	19.97	3.45	11.78
					27	80.6	5.05	17.24	4.09	13.96	5.74	19.59	4.36	14.89	5.91	20.17	3.84	13.11
					31	87.8	5.10	17.41	4.29	14.62	5.80	19.78	4.58	15.63	5.97	20.38	4.18	14.26
	1020	600	50	0.2	23	73.4	4.59	15.65	3.44	11.74	5.21	17.78	3.65	12.45	5.37	18.31	2.90	9.89
					24	75.2	4.63	15.81	3.71	12.65	5.26	17.96	3.84	13.11	5.42	18.50	3.20	10.92
					27	80.6	4.68	15.97	3.79	12.93	5.32	18.14	4.04	13.79	5.48	18.69	3.56	12.15
					31	87.8	4.73	16.13	3.97	13.55	5.37	18.32	4.24	14.48	5.53	18.87	3.87	13.21

GFH30K3FI:

Fan Speed	Air Flow Rate		ESP		Entering Air DBT		Outdoor Air Dry Bulb Temperature 77°F(25°C)											
							Indoor Air Wet Bulb Temperature °F(°C)											
					62°F(17°C)				67°F(19°C)				72°F(22°C)					
	m ³ /hr	cfm	Pa	in.wg	°C	°F	Total Capacity		Sensible Capacity		Total Capacity		Sensible Capacity		Total Capacity		Sensible Capacity	
						kW	Mbh	kW	Mbh	kW	Mbh	kW	Mbh	kW	Mbh	kW	Mbh	
High	1760	1036	0	0	23	73.4	8.45	28.82	6.34	21.62	9.60	32.75	6.72	22.93	9.89	33.73	5.34	18.22
					24	75.2	8.53	29.11	6.83	23.29	9.70	33.08	7.08	24.15	9.99	34.08	5.89	20.11
					27	80.6	8.62	29.41	6.98	23.82	9.79	33.42	7.44	25.40	10.09	34.42	6.56	22.37
					31	87.8	8.71	29.70	7.31	24.95	9.89	33.75	7.81	26.66	10.19	34.77	7.13	24.34
	1520	895	25	0.1	23	73.4	7.97	27.19	5.98	20.39	9.06	30.90	6.34	21.63	9.33	31.82	5.04	17.18
					24	75.2	8.05	27.47	6.44	21.97	9.15	31.21	6.68	22.78	9.42	32.15	5.56	18.97
					27	80.6	8.13	27.74	6.59	22.47	9.24	31.53	7.02	23.96	9.52	32.47	6.19	21.11
					31	87.8	8.21	28.02	6.90	23.54	9.33	31.84	7.37	25.16	9.61	32.80	6.73	22.96
	1400	824	37	0.15	23	73.4	7.57	25.83	5.68	19.37	8.60	29.35	6.02	20.55	8.86	30.23	4.78	16.33
					24	75.2	7.65	26.09	6.12	20.87	8.69	29.65	6.34	21.65	8.95	30.54	5.28	18.02
					27	80.6	7.72	26.36	6.26	21.35	8.78	29.95	6.67	22.76	9.04	30.85	5.88	20.05
					31	87.8	7.80	26.62	6.55	22.36	8.87	30.25	7.00	23.90	9.13	31.16	6.39	21.81
	1300	765	50	0.2	23	73.4	7.01	23.93	5.26	17.94	7.97	27.19	5.58	19.03	8.21	28.00	4.43	15.12
					24	75.2	7.08	24.17	5.67	19.34	8.05	27.47	5.88	20.05	8.29	28.29	4.89	16.69
					27	80.6	7.16	24.41	5.80	19.78	8.13	27.74	6.18	21.09	8.38	28.58	5.44	18.57
					31	87.8	7.23	24.66	6.07	20.71	8.21	28.02	6.49	22.14	8.46	28.86	5.92	20.20

Fan Speed	Air Flow Rate		ESP		Entering Air DBT		Outdoor Air Dry Bulb Temperature 95°F(35°C)											
							Indoor Air Wet Bulb Temperature °F(°C)											
					62°F(17°C)				67°F(19°C)				72°F(22°C)					
	m ³ /hr	cfm	Pa	in.wg	°C	°F	Total Capacity		Sensible Capacity		Total Capacity		Sensible Capacity		Total Capacity		Sensible Capacity	
						kW	Mbh	kW	Mbh	kW	Mbh	kW	Mbh	kW	Mbh	kW	Mbh	
High	1760	1036	0	0	23	73.4	7.68	26.20	5.76	19.65	8.73	29.77	6.11	20.84	8.99	30.67	4.85	16.56
					24	75.2	7.76	26.47	6.21	21.17	8.81	30.08	6.43	21.96	9.08	30.98	5.36	18.28
					27	80.6	7.84	26.73	6.35	21.66	8.90	30.38	6.77	23.09	9.17	31.29	5.96	20.34
					31	87.8	7.91	27.00	6.65	22.68	8.99	30.68	7.10	24.24	9.26	31.60	6.48	22.12
	1520	895	25	0.1	23	73.4	7.24	24.72	5.43	18.54	8.23	28.09	5.76	19.66	8.48	28.93	4.58	15.62
					24	75.2	7.32	24.97	5.85	19.98	8.32	28.37	6.07	20.71	8.57	29.23	5.05	17.24
					27	80.6	7.39	25.22	5.99	20.43	8.40	28.66	6.38	21.78	8.65	29.52	5.62	19.19
					31	87.8	7.47	25.47	6.27	21.40	8.48	28.95	6.70	22.87	8.74	29.82	6.12	20.87
	1400	824	37	0.15	23	73.4	6.88	23.48	5.16	17.61	7.82	26.68	5.47	18.68	8.06	27.48	4.35	14.84
					24	75.2	6.95	23.72	5.56	18.98	7.90	26.96	5.77	19.68	8.14	27.76	4.80	16.38
					27	80.6	7.02	23.96	5.69	19.41	7.98	27.23	6.06	20.69	8.22	28.04	5.34	18.23
					31	87.8	7.09	24.20	5.96	20.33	8.06	27.50	6.37	21.73	8.30	28.33	5.81	19.83
	1300	765	50	0.2	23	73.4	6.37	21.75	4.78	16.31	7.24	24.72	5.07	17.30	7.46	25.46	4.03	13.75
					24	75.2	6.44	21.97	5.15	17.58	7.32	24.97	5.34	18.23	7.54	25.72	4.45	15.17
					27	80.6	6.50	22.19	5.27	17.98	7.39	25.22	5.62	19.17	7.61	25.98	4.95	16.89
					31	87.8	6.57	22.42	5.52	18.83	7.47	25.47	5.90	20.12	7.69	26.24	5.38	18.37

DC Inverter U-match Air Conditioners Technical Sales Guide

Fan Speed	Air Flow Rate		ESP		Entering Air DBT		Outdoor Air Dry Bulb Temperature 110°F(43°C)											
							Indoor Air Wet Bulb Temperature °F(°C)											
					62°F(17°C)				67°F(19°C)				72°F(22°C)					
	m ³ /hr	cfm	Pa	in.wg	°C	°F	Total Capacity		Sensible Capacity		Total Capacity		Sensible Capacity		Total Capacity		Sensible Capacity	
						kW	Mbh	kW	Mbh	kW	Mbh	kW	Mbh	kW	Mbh	kW	Mbh	
High	1760	1036	0	0	23	73.4	6.91	23.58	5.18	17.69	7.85	26.80	5.50	18.76	8.09	27.60	4.37	14.90
					24	75.2	6.98	23.82	5.59	19.06	7.93	27.07	5.79	19.76	8.17	27.88	4.82	16.45
					27	80.6	7.05	24.06	5.71	19.49	8.01	27.34	6.09	20.78	8.25	28.16	5.37	18.31
					31	87.8	7.12	24.30	5.98	20.41	8.09	27.62	6.39	21.82	8.34	28.44	5.84	19.91
	1520	895	25	0.1	23	73.4	6.52	22.25	4.89	16.68	7.41	25.28	5.19	17.70	7.63	26.04	4.12	14.06
					24	75.2	6.59	22.47	5.27	17.98	7.48	25.54	5.46	18.64	7.71	26.30	4.55	15.52
					27	80.6	6.65	22.70	5.39	18.39	7.56	25.79	5.75	19.60	7.79	26.57	5.06	17.27
					31	87.8	6.72	22.93	5.64	19.26	7.64	26.05	6.03	20.58	7.86	26.83	5.51	18.78
	1400	824	37	0.15	23	73.4	6.19	21.13	4.65	15.85	7.04	24.01	4.93	16.81	7.25	24.74	3.91	13.36
					24	75.2	6.26	21.35	5.01	17.08	7.11	24.26	5.19	17.71	7.32	24.99	4.32	14.74
					27	80.6	6.32	21.56	5.12	17.47	7.18	24.50	5.46	18.62	7.40	25.24	4.81	16.41
					31	87.8	6.38	21.78	5.36	18.30	7.25	24.75	5.73	19.55	7.47	25.49	5.23	17.84
	1300	765	50	0.2	23	73.4	5.74	19.58	4.30	14.68	6.52	22.25	4.56	15.57	6.72	22.91	3.63	12.37
					24	75.2	5.80	19.78	4.64	15.82	6.59	22.47	4.81	16.40	6.78	23.15	4.00	13.66
					27	80.6	5.85	19.98	4.74	16.18	6.65	22.70	5.06	17.25	6.85	23.38	4.45	15.20
					31	87.8	5.91	20.18	4.97	16.95	6.72	22.93	5.31	18.11	6.92	23.61	4.84	16.53

Fan Speed	Air Flow Rate		ESP		Entering Air DBT		Outdoor Air Dry Bulb Temperature 77°F(25°C)											
							Indoor Air Wet Bulb Temperature °F(°C)											
					62°F(17°C)				67°F(19°C)				72°F(22°C)					
	m ³ /hr	cfm	Pa	in.wg	°C	°F	Total Capacity		Sensible Capacity		Total Capacity		Sensible Capacity		Total Capacity		Sensible Capacity	
						kW	Mbh	kW	Mbh	kW	Mbh	kW	Mbh	kW	Mbh	kW	Mbh	
Medium	1620	954	0	0	23	73.4	8.02	27.38	6.02	20.53	9.12	31.11	6.38	21.78	9.39	32.05	5.07	17.30
					24	75.2	8.11	27.66	6.48	22.13	9.21	31.43	6.72	22.94	9.49	32.37	5.60	19.10
					27	80.6	8.19	27.94	6.63	22.63	9.30	31.75	7.07	24.13	9.58	32.70	6.23	21.25
					31	87.8	8.27	28.22	6.95	23.70	9.40	32.07	7.42	25.33	9.68	33.03	6.78	23.12
	1400	824	25	0.1	23	73.4	7.57	25.83	5.68	19.37	8.60	29.35	6.02	20.55	8.86	30.23	4.78	16.33
					24	75.2	7.65	26.09	6.12	20.87	8.69	29.65	6.34	21.65	8.95	30.54	5.28	18.02
					27	80.6	7.72	26.36	6.26	21.35	8.78	29.95	6.67	22.76	9.04	30.85	5.88	20.05
					31	87.8	7.80	26.62	6.55	22.36	8.87	30.25	7.00	23.90	9.13	31.16	6.39	21.81
	1300	765	37	0.15	23	73.4	7.19	24.54	5.39	18.40	8.17	27.88	5.72	19.52	8.42	28.72	4.55	15.51
					24	75.2	7.27	24.79	5.81	19.83	8.26	28.17	6.03	20.56	8.50	29.01	5.02	17.12
					27	80.6	7.34	25.04	5.94	20.28	8.34	28.45	6.34	21.62	8.59	29.31	5.58	19.05
					31	87.8	7.41	25.29	6.23	21.24	8.42	28.74	6.65	22.70	8.68	29.60	6.07	20.72
	1140	671	50	0.2	23	73.4	6.66	22.73	5.00	17.05	7.57	25.83	5.30	18.08	7.80	26.60	4.21	14.37
					24	75.2	6.73	22.96	5.38	18.37	7.65	26.09	5.58	19.05	7.88	26.88	4.65	15.86
					27	80.6	6.80	23.19	5.51	18.79	7.72	26.36	5.87	20.03	7.96	27.15	5.17	17.65
					31	87.8	6.87	23.43	5.77	19.68	7.80	26.62	6.16	21.03	8.04	27.42	5.63	19.19

Fan Speed	Air Flow Rate		ESP		Entering Air DBT		Outdoor Air Dry Bulb Temperature 95°F(35°C)											
							Indoor Air Wet Bulb Temperature °F(°C)											
							62°F(17°C)				67°F(19°C)				72°F(22°C)			
							Total Capacity		Sensible Capacity		Total Capacity		Sensible Capacity		Total Capacity		Sensible Capacity	
m ³ /hr	cfm	Pa	in.wg	°C	°F	kW	Mbh	kW	Mbh	kW	Mbh	kW	Mbh	kW	Mbh	kW	Mbh	
Medium	1620	954	0	0	23	73.4	7.29	24.89	5.47	18.67	8.29	28.28	5.80	19.80	8.54	29.13	4.61	15.73
					24	75.2	7.37	25.14	5.90	20.12	8.37	28.57	6.11	20.86	8.63	29.43	5.09	17.36
					27	80.6	7.44	25.40	6.03	20.57	8.46	28.86	6.43	21.93	8.71	29.73	5.66	19.32
					31	87.8	7.52	25.65	6.32	21.55	8.54	29.15	6.75	23.03	8.80	30.02	6.16	21.02
	1400	824	25	0.1	23	73.4	6.88	23.48	5.16	17.61	7.82	26.68	5.47	18.68	8.06	27.48	4.35	14.84
					24	75.2	6.95	23.72	5.56	18.98	7.90	26.96	5.77	19.68	8.14	27.76	4.80	16.38
					27	80.6	7.02	23.96	5.69	19.41	7.98	27.23	6.06	20.69	8.22	28.04	5.34	18.23
					31	87.8	7.09	24.20	5.96	20.33	8.06	27.50	6.37	21.73	8.30	28.33	5.81	19.83
	1300	765	37	0.15	23	73.4	6.54	22.31	4.90	16.73	7.43	25.35	5.20	17.74	7.65	26.11	4.13	14.10
					24	75.2	6.60	22.53	5.28	18.03	7.51	25.61	5.48	18.69	7.73	26.38	4.56	15.56
					27	80.6	6.67	22.76	5.40	18.44	7.58	25.87	5.76	19.66	7.81	26.64	5.08	17.32
					31	87.8	6.74	22.99	5.66	19.31	7.66	26.13	6.05	20.64	7.89	26.91	5.52	18.84
	1140	671	50	0.2	23	73.4	6.06	20.66	4.54	15.50	6.88	23.48	4.82	16.44	7.09	24.19	3.83	13.06
					24	75.2	6.12	20.87	4.89	16.70	6.95	23.72	5.08	17.32	7.16	24.43	4.22	14.42
					27	80.6	6.18	21.09	5.01	17.08	7.02	23.96	5.34	18.21	7.23	24.68	4.70	16.04
					31	87.8	6.24	21.30	5.24	17.89	7.09	24.20	5.60	19.12	7.31	24.93	5.11	17.45

Fan Speed	Air Flow Rate		ESP		Entering Air DBT		Outdoor Air Dry Bulb Temperature 110°F(43°C)											
							Indoor Air Wet Bulb Temperature °F(°C)											
							62°F(17°C)				67°F(19°C)				72°F(22°C)			
							Total Capacity		Sensible Capacity		Total Capacity		Sensible Capacity		Total Capacity		Sensible Capacity	
m ³ /hr	cfm	Pa	in.wg	°C	°F	kW	Mbh	kW	Mbh	kW	Mbh	kW	Mbh	kW	Mbh	kW	Mbh	
Medium	1620	954	0	0	23	73.4	6.57	22.40	4.92	16.80	7.46	25.46	5.22	17.82	7.68	26.22	4.15	14.16
					24	75.2	6.63	22.63	5.31	18.10	7.54	25.72	5.50	18.77	7.76	26.49	4.58	15.63
					27	80.6	6.70	22.86	5.43	18.52	7.61	25.98	5.79	19.74	7.84	26.75	5.10	17.39
					31	87.8	6.77	23.09	5.68	19.39	7.69	26.24	6.07	20.73	7.92	27.02	5.54	18.92
	1400	824	25	0.1	23	73.4	6.19	21.13	4.65	15.85	7.04	24.01	4.93	16.81	7.25	24.74	3.91	13.36
					24	75.2	6.26	21.35	5.01	17.08	7.11	24.26	5.19	17.71	7.32	24.99	4.32	14.74
					27	80.6	6.32	21.56	5.12	17.47	7.18	24.50	5.46	18.62	7.40	25.24	4.81	16.41
					31	87.8	6.38	21.78	5.36	18.30	7.25	24.75	5.73	19.55	7.47	25.49	5.23	17.84
	1300	765	37	0.15	23	73.4	5.88	20.08	4.41	15.06	6.69	22.81	4.68	15.97	6.89	23.50	3.72	12.69
					24	75.2	5.94	20.28	4.76	16.23	6.75	23.05	4.93	16.82	6.96	23.74	4.10	14.01
					27	80.6	6.00	20.49	4.86	16.59	6.82	23.28	5.19	17.69	7.03	23.98	4.57	15.59
					31	87.8	6.06	20.69	5.09	17.38	6.89	23.51	5.44	18.57	7.10	24.22	4.97	16.95
	1140	671	50	0.2	23	73.4	5.45	18.60	4.09	13.95	6.19	21.13	4.34	14.79	6.38	21.77	3.44	11.75
					24	75.2	5.51	18.79	4.40	15.03	6.26	21.35	4.57	15.58	6.44	21.99	3.80	12.97
					27	80.6	5.56	18.98	4.51	15.37	6.32	21.56	4.80	16.39	6.51	22.21	4.23	14.44
					31	87.8	5.62	19.17	4.72	16.10	6.38	21.78	5.04	17.21	6.57	22.43	4.60	15.70

DC Inverter U-match Air Conditioners Technical Sales Guide

Fan Speed	Air Flow Rate		ESP		Entering Air DBT		Outdoor Air Dry Bulb Temperature 77°F(25°C)											
							Indoor Air Wet Bulb Temperature °F(°C)											
					62°F(17°C)		67°F(19°C)		72°F(22°C)									
	m ³ /hr	cfm	Pa	in.wg	°C	°F	Total Capacity	Sensible Capacity	Total Capacity	Sensible Capacity	Total Capacity	Sensible Capacity	Total Capacity	Sensible Capacity				
						kW	Mbh	kW	Mbh	kW	Mbh	kW	Mbh	kW	Mbh	kW	Mbh	
Low	1520	895	0	0	23	73.4	7.60	25.94	5.70	19.45	8.64	29.48	6.05	20.63	8.90	30.36	4.80	16.39
					24	75.2	7.68	26.20	6.14	20.96	8.73	29.78	6.37	21.74	8.99	30.67	5.30	18.09
					27	80.6	7.76	26.47	6.28	21.44	8.81	30.08	6.70	22.86	9.08	30.98	5.90	20.14
					31	87.8	7.83	26.73	6.58	22.45	8.90	30.38	7.03	24.00	9.17	31.29	6.42	21.90
	1300	765	25	0.1	23	73.4	7.17	24.47	5.38	18.35	8.15	27.81	5.70	19.46	8.39	28.64	4.53	15.47
					24	75.2	7.24	24.72	5.80	19.78	8.23	28.09	6.01	20.51	8.48	28.93	5.00	17.07
					27	80.6	7.32	24.97	5.93	20.23	8.32	28.37	6.32	21.56	8.57	29.23	5.57	19.00
					31	87.8	7.39	25.22	6.21	21.18	8.40	28.66	6.64	22.64	8.65	29.52	6.06	20.66
	1200	706	37	0.15	23	73.4	6.81	23.25	5.11	17.43	7.74	26.42	5.42	18.49	7.97	27.21	4.31	14.69
					24	75.2	6.88	23.48	5.51	18.79	7.82	26.69	5.71	19.48	8.06	27.49	4.75	16.22
					27	80.6	6.95	23.72	5.63	19.21	7.90	26.96	6.00	20.49	8.14	27.76	5.29	18.05
					31	87.8	7.02	23.96	5.90	20.12	7.98	27.23	6.30	21.51	8.22	28.04	5.75	19.63
	1020	600	50	0.2	23	73.4	6.31	21.53	4.73	16.15	7.17	24.47	5.02	17.13	7.39	25.20	3.99	13.61
					24	75.2	6.38	21.75	5.10	17.40	7.24	24.72	5.29	18.05	7.46	25.46	4.40	15.02
					27	80.6	6.44	21.97	5.22	17.80	7.32	24.97	5.56	18.98	7.54	25.72	4.90	16.72
					31	87.8	6.50	22.19	5.46	18.64	7.39	25.22	5.84	19.92	7.61	25.98	5.33	18.18

Fan Speed	Air Flow Rate		ESP		Entering Air DBT		Outdoor Air Dry Bulb Temperature 95°F(35°C)											
							Indoor Air Wet Bulb Temperature °F(°C)											
					62°F(17°C)		67°F(19°C)		72°F(22°C)									
	m ³ /hr	cfm	Pa	in.wg	°C	°F	Total Capacity	Sensible Capacity	Total Capacity	Sensible Capacity	Total Capacity	Sensible Capacity	Total Capacity	Sensible Capacity				
						kW	Mbh	kW	Mbh	kW	Mbh	kW	Mbh	kW	Mbh	kW	Mbh	
Low	1520	895	0	0	23	73.4	6.91	23.58	5.18	17.69	7.85	26.80	5.50	18.76	8.09	27.60	4.37	14.90
					24	75.2	6.98	23.82	5.59	19.06	7.93	27.07	5.79	19.76	8.17	27.88	4.82	16.45
					27	80.6	7.05	24.06	5.71	19.49	8.01	27.34	6.09	20.78	8.25	28.16	5.37	18.31
					31	87.8	7.12	24.30	5.98	20.41	8.09	27.62	6.39	21.82	8.34	28.44	5.84	19.91
	1300	765	25	0.1	23	73.4	6.52	22.25	4.89	16.68	7.41	25.28	5.19	17.70	7.63	26.04	4.12	14.06
					24	75.2	6.59	22.47	5.27	17.98	7.48	25.54	5.46	18.64	7.71	26.30	4.55	15.52
					27	80.6	6.65	22.70	5.39	18.39	7.56	25.79	5.75	19.60	7.79	26.57	5.06	17.27
					31	87.8	6.72	22.93	5.64	19.26	7.64	26.05	6.03	20.58	7.86	26.83	5.51	18.78
	1200	706	37	0.15	23	73.4	6.19	21.13	4.65	15.85	7.04	24.01	4.93	16.81	7.25	24.74	3.91	13.36
					24	75.2	6.26	21.35	5.01	17.08	7.11	24.26	5.19	17.71	7.32	24.99	4.32	14.74
					27	80.6	6.32	21.56	5.12	17.47	7.18	24.50	5.46	18.62	7.40	25.24	4.81	16.41
					31	87.8	6.38	21.78	5.36	18.30	7.25	24.75	5.73	19.55	7.47	25.49	5.23	17.84
	1020	600	50	0.2	23	73.4	5.74	19.58	4.30	14.68	6.52	22.25	4.56	15.57	6.72	22.91	3.63	12.37
					24	75.2	5.80	19.78	4.64	15.82	6.59	22.47	4.81	16.40	6.78	23.15	4.00	13.66
					27	80.6	5.85	19.98	4.74	16.18	6.65	22.70	5.06	17.25	6.85	23.38	4.45	15.20
					31	87.8	5.91	20.18	4.97	16.95	6.72	22.93	5.31	18.11	6.92	23.61	4.84	16.53

Fan Speed	Air Flow Rate		ESP		Entering Air DBT		Outdoor Air Dry Bulb Temperature 110°F(43°C)											
							Indoor Air Wet Bulb Temperature °F(°C)											
	m ³ /hr cfm		Pa in.wg		°C °F		62°F(17°C)				67°F(19°C)				72°F(22°C)			
							Total Capacity		Sensible Capacity		Total Capacity		Sensible Capacity		Total Capacity		Sensible Capacity	
						kW	Mbh	kW	Mbh	kW	Mbh	kW	Mbh	kW	Mbh	kW	Mbh	
Low	1520	895	0	0	23	73.4	6.22	21.22	4.66	15.92	7.07	24.12	4.95	16.88	7.28	24.84	3.93	13.41
					24	75.2	6.28	21.44	5.03	17.15	7.14	24.36	5.21	17.78	7.35	25.09	4.34	14.80
					27	80.6	6.35	21.66	5.14	17.54	7.21	24.61	5.48	18.70	7.43	25.35	4.83	16.48
					31	87.8	6.41	21.87	5.38	18.37	7.28	24.85	5.75	19.63	7.50	25.60	5.25	17.92
	1300	765	25	0.1	23	73.4	5.87	20.02	4.40	15.02	6.67	22.75	4.67	15.93	6.87	23.43	3.71	12.65
					24	75.2	5.93	20.23	4.74	16.18	6.74	22.98	4.92	16.78	6.94	23.67	4.09	13.97
					27	80.6	5.99	20.43	4.85	16.55	6.80	23.22	5.17	17.64	7.01	23.91	4.56	15.54
					31	87.8	6.05	20.63	5.08	17.33	6.87	23.45	5.43	18.52	7.08	24.15	4.95	16.91
	1200	706	37	0.15	23	73.4	5.57	19.02	4.18	14.26	6.33	21.61	4.43	15.13	6.52	22.26	3.52	12.02
					24	75.2	5.63	19.21	4.51	15.37	6.40	21.83	4.67	15.94	6.59	22.49	3.89	13.27
					27	80.6	5.69	19.41	4.61	15.72	6.46	22.05	4.91	16.76	6.66	22.72	4.33	14.77
					31	87.8	5.75	19.60	4.83	16.47	6.53	22.28	5.16	17.60	6.72	22.94	4.71	16.06
	1020	600	50	0.2	23	73.4	5.16	17.62	3.87	13.21	5.87	20.02	4.11	14.01	6.04	20.62	3.26	11.14
					24	75.2	5.22	17.80	4.17	14.24	5.93	20.23	4.33	14.76	6.11	20.83	3.60	12.29
					27	80.6	5.27	17.98	4.27	14.56	5.99	20.43	4.55	15.53	6.17	21.04	4.01	13.68
					31	87.8	5.32	18.16	4.47	15.25	6.05	20.63	4.78	16.30	6.23	21.25	4.36	14.88

GFH36K3FI:

Fan Speed	Air Flow Rate		ESP		Entering Air DBT		Outdoor Air Dry Bulb Temperature 77°F(25°C)											
							Indoor Air Wet Bulb Temperature °F(°C)											
	m ³ /hr cfm		Pa in.wg		°C °F		62°F(17°C)				67°F(19°C)				72°F(22°C)			
							Total Capacity		Sensible Capacity		Total Capacity		Sensible Capacity		Total Capacity		Sensible Capacity	
						kW	Mbh	kW	Mbh	kW	Mbh	kW	Mbh	kW	Mbh	kW	Mbh	
High	2500	1471	0	0	23	73.4	11.06	37.74	8.30	28.31	12.57	42.89	8.80	30.02	12.95	44.17	6.99	23.85
					24	75.2	11.17	38.13	8.94	30.50	12.70	43.32	9.27	31.63	13.08	44.62	7.72	26.33
					27	80.6	11.29	38.51	9.14	31.19	12.83	43.76	9.75	33.26	13.21	45.08	8.59	29.30
					31	87.8	11.40	38.90	9.58	32.67	12.95	44.20	10.23	34.92	13.34	45.53	9.34	31.87
	2260	1330	25	0.1	23	73.4	10.44	35.60	7.83	26.70	11.86	40.46	8.30	28.32	12.21	41.67	6.60	22.50
					24	75.2	10.54	35.97	8.43	28.77	11.98	40.87	8.74	29.84	12.34	42.10	7.28	24.84
					27	80.6	10.65	36.33	8.62	29.43	12.10	41.29	9.20	31.38	12.46	42.52	8.10	27.64
					31	87.8	10.75	36.69	9.03	30.82	12.22	41.70	9.65	32.94	12.59	42.95	8.81	30.06
	2100	1236	37	0.15	23	73.4	9.91	33.82	7.43	25.37	11.27	38.44	7.89	26.91	11.60	39.59	6.27	21.38
					24	75.2	10.01	34.17	8.01	27.34	11.38	38.83	8.31	28.34	11.72	39.99	6.92	23.60
					27	80.6	10.12	34.51	8.19	27.96	11.50	39.22	8.74	29.81	11.84	40.40	7.70	26.26
					31	87.8	10.22	34.86	8.58	29.28	11.61	39.61	9.17	31.29	11.96	40.80	8.37	28.56
	1980	1165	50	0.2	23	73.4	9.18	31.33	6.89	23.50	10.44	35.60	7.30	24.92	10.75	36.67	5.80	19.80
					24	75.2	9.28	31.65	7.42	25.32	10.54	35.97	7.70	26.26	10.86	37.05	6.41	21.86
					27	80.6	9.37	31.97	7.59	25.90	10.65	36.33	8.09	27.61	10.97	37.42	7.13	24.32
					31	87.8	9.46	32.29	7.95	27.12	10.75	36.69	8.50	28.99	11.08	37.80	7.75	26.46

DC Inverter U-match Air Conditioners Technical Sales Guide

Fan Speed	Air Flow Rate		ESP		Entering Air DBT		Outdoor Air Dry Bulb Temperature 95°F(35°C)											
							Indoor Air Wet Bulb Temperature °F(°C)											
					62°F(17°C)		67°F(19°C)		72°F(22°C)									
	m³/hr	cfm	Pa	in.wg	°C	°F	Total Capacity	Sensible Capacity	Total Capacity	Sensible Capacity	Total Capacity	Sensible Capacity						
						kW	Mbh	kW	Mbh	kW	Mbh	kW	Mbh	kW	Mbh	kW	Mbh	
High	2500	1471	0	0	23	73.4	10.06	34.31	7.54	25.73	11.43	38.99	8.00	27.29	11.77	40.16	6.36	21.69
					24	75.2	10.16	34.66	8.13	27.73	11.54	39.39	8.43	28.75	11.89	40.57	7.01	23.93
					27	80.6	10.26	35.01	8.31	28.36	11.66	39.78	8.86	30.24	12.01	40.98	7.81	26.64
					31	87.8	10.36	35.36	8.71	29.70	11.78	40.18	9.30	31.74	12.13	41.39	8.49	28.97
	2260	1330	25	0.1	23	73.4	9.49	32.37	7.11	24.28	10.78	36.78	7.55	25.75	11.10	37.88	6.00	20.46
					24	75.2	9.58	32.70	7.67	26.16	10.89	37.16	7.95	27.12	11.22	38.27	6.62	22.58
					27	80.6	9.68	33.03	7.84	26.75	11.00	37.53	8.36	28.52	11.33	38.66	7.36	25.13
					31	87.8	9.78	33.36	8.21	28.02	11.11	37.91	8.78	29.95	11.44	39.04	8.01	27.33
	2100	1236	37	0.15	23	73.4	9.01	30.75	6.76	23.06	10.24	34.94	7.17	24.46	10.55	35.99	5.70	19.43
					24	75.2	9.10	31.06	7.28	24.85	10.35	35.30	7.55	25.77	10.66	36.36	6.29	21.45
					27	80.6	9.20	31.38	7.45	25.42	10.45	35.66	7.94	27.10	10.76	36.73	7.00	23.87
					31	87.8	9.29	31.69	7.80	26.62	10.55	36.01	8.34	28.45	10.87	37.09	7.61	25.96
1980	1165	50	0.2	23	73.4	8.35	28.48	6.26	21.36	9.49	32.37	6.64	22.66	9.77	33.34	5.28	18.00	
				24	75.2	8.43	28.77	6.75	23.02	9.58	32.70	7.00	23.87	9.87	33.68	5.82	19.87	
				27	80.6	8.52	29.06	6.90	23.54	9.68	33.03	7.36	25.10	9.97	34.02	6.48	22.11	
				31	87.8	8.60	29.36	7.23	24.66	9.78	33.36	7.72	26.35	10.07	34.36	7.05	24.05	

Fan Speed	Air Flow Rate		ESP		Entering Air DBT		Outdoor Air Dry Bulb Temperature 110°F(43°C)											
							Indoor Air Wet Bulb Temperature °F(°C)											
					62°F(17°C)		67°F(19°C)		72°F(22°C)									
	m³/hr	cfm	Pa	in.wg	°C	°F	Total Capacity	Sensible Capacity	Total Capacity	Sensible Capacity	Total Capacity	Sensible Capacity						
						kW	Mbh	kW	Mbh	kW	Mbh	kW	Mbh	kW	Mbh	kW	Mbh	
High	2500	1471	0	0	23	73.4	9.05	30.88	6.79	23.16	10.28	35.09	7.20	24.56	10.59	36.14	5.72	19.52
					24	75.2	9.14	31.19	7.31	24.96	10.39	35.45	7.58	25.88	10.70	36.51	6.31	21.54
					27	80.6	9.23	31.51	7.48	25.52	10.49	35.81	7.98	27.21	10.81	36.88	7.03	23.97
					31	87.8	9.33	31.82	7.83	26.73	10.60	36.16	8.37	28.57	10.92	37.25	7.64	26.07
	2260	1330	25	0.1	23	73.4	8.54	29.13	6.40	21.85	9.70	33.10	6.79	23.17	9.99	34.10	5.40	18.41
					24	75.2	8.62	29.43	6.90	23.54	9.80	33.44	7.15	24.41	10.10	34.44	5.96	20.32
					27	80.6	8.71	29.73	7.06	24.08	9.90	33.78	7.52	25.67	10.20	34.79	6.63	22.61
					31	87.8	8.80	30.02	7.39	25.22	10.00	34.12	7.90	26.95	10.30	35.14	7.21	24.60
	2100	1236	37	0.15	23	73.4	8.11	27.67	6.08	20.76	9.22	31.45	6.45	22.01	9.49	32.39	5.13	17.49
					24	75.2	8.19	27.96	6.55	22.37	9.31	31.77	6.80	23.19	9.59	32.72	5.66	19.31
					27	80.6	8.28	28.24	6.70	22.87	9.41	32.09	7.15	24.39	9.69	33.05	6.30	21.48
					31	87.8	8.36	28.52	7.02	23.96	9.50	32.41	7.50	25.60	9.78	33.38	6.85	23.37
1980	1165	50	0.2	23	73.4	7.51	25.64	5.63	19.23	8.54	29.13	5.98	20.39	8.79	30.00	4.75	16.20	
				24	75.2	7.59	25.90	6.07	20.72	8.62	29.43	6.30	21.48	8.88	30.31	5.24	17.88	
				27	80.6	7.67	26.16	6.21	21.19	8.71	29.73	6.62	22.59	8.97	30.62	5.83	19.90	
				31	87.8	7.74	26.42	6.50	22.19	8.80	30.02	6.95	23.72	9.06	30.92	6.34	21.65	

Fan Speed	Air Flow Rate		ESP		Entering Air DBT		Outdoor Air Dry Bulb Temperature 77°F(25°C)											
							Indoor Air Wet Bulb Temperature °F(°C)											
							62°F(17°C)				67°F(19°C)				72°F(22°C)			
							Total Capacity		Sensible Capacity		Total Capacity		Sensible Capacity		Total Capacity		Sensible Capacity	
m ³ /hr	cfm	Pa	in.wg	°C	°F	kW	Mbh	kW	Mbh	kW	Mbh	kW	Mbh	kW	Mbh	kW	Mbh	
Medium	2380	1401	0	0	23	73.4	10.51	35.85	7.88	26.89	11.94	40.74	8.36	28.52	12.30	41.96	6.64	22.66
					24	75.2	10.62	36.22	8.49	28.98	12.06	41.16	8.81	30.05	12.42	42.39	7.33	25.01
					27	80.6	10.72	36.59	8.69	29.63	12.18	41.57	9.26	31.60	12.55	42.82	8.16	27.83
					31	87.8	10.83	36.95	9.10	31.04	12.31	41.99	9.72	33.17	12.68	43.25	8.87	30.27
	2150	1265	25	0.1	23	73.4	9.91	33.82	7.43	25.37	11.27	38.44	7.89	26.91	11.60	39.59	6.27	21.38
					24	75.2	10.01	34.17	8.01	27.34	11.38	38.83	8.31	28.34	11.72	39.99	6.92	23.60
					27	80.6	10.12	34.51	8.19	27.96	11.50	39.22	8.74	29.81	11.84	40.40	7.70	26.26
					31	87.8	10.22	34.86	8.58	29.28	11.61	39.61	9.17	31.29	11.96	40.80	8.37	28.56
	2020	1189	37	0.15	23	73.4	9.42	32.13	7.06	24.10	10.70	36.51	7.49	25.56	11.02	37.61	5.95	20.31
					24	75.2	9.51	32.46	7.61	25.97	10.81	36.89	7.89	26.93	11.14	37.99	6.57	22.42
					27	80.6	9.61	32.79	7.78	26.56	10.92	37.26	8.30	28.32	11.25	38.38	7.31	24.95
					31	87.8	9.71	33.12	8.15	27.82	11.03	37.63	8.71	29.73	11.36	38.76	7.95	27.13
	1860	1095	50	0.2	23	73.4	8.72	29.77	6.54	22.32	9.91	33.82	6.94	23.68	10.21	34.84	5.51	18.81
					24	75.2	8.81	30.07	7.05	24.06	10.01	34.17	7.31	24.94	10.31	35.19	6.09	20.76
					27	80.6	8.90	30.37	7.21	24.60	10.12	34.51	7.69	26.23	10.42	35.55	6.77	23.11
					31	87.8	8.99	30.68	7.55	25.77	10.22	34.86	8.07	27.54	10.52	35.91	7.37	25.13

Fan Speed	Air Flow Rate		ESP		Entering Air DBT		Outdoor Air Dry Bulb Temperature 95°F(35°C)											
							Indoor Air Wet Bulb Temperature °F(°C)											
							62°F(17°C)				67°F(19°C)				72°F(22°C)			
							Total Capacity		Sensible Capacity		Total Capacity		Sensible Capacity		Total Capacity		Sensible Capacity	
m ³ /hr	cfm	Pa	in.wg	°C	°F	kW	Mbh	kW	Mbh	kW	Mbh	kW	Mbh	kW	Mbh	kW	Mbh	
Medium	2380	1401	0	0	23	73.4	9.55	32.59	7.16	24.45	10.86	37.04	7.60	25.93	11.18	38.15	6.04	20.60
					24	75.2	9.65	32.93	7.72	26.34	10.97	37.42	8.01	27.31	11.30	38.54	6.66	22.74
					27	80.6	9.75	33.26	7.90	26.94	11.08	37.79	8.42	28.72	11.41	38.93	7.42	25.30
					31	87.8	9.85	33.59	8.27	28.22	11.19	38.17	8.84	30.16	11.52	39.32	8.07	27.52
	2150	1265	25	0.1	23	73.4	9.01	30.75	6.76	23.06	10.24	34.94	7.17	24.46	10.55	35.99	5.70	19.43
					24	75.2	9.10	31.06	7.28	24.85	10.35	35.30	7.55	25.77	10.66	36.36	6.29	21.45
					27	80.6	9.20	31.38	7.45	25.42	10.45	35.66	7.94	27.10	10.76	36.73	7.00	23.87
					31	87.8	9.29	31.69	7.80	26.62	10.55	36.01	8.34	28.45	10.87	37.09	7.61	25.96
	2020	1189	37	0.15	23	73.4	8.56	29.21	6.42	21.91	9.73	33.20	6.81	23.24	10.02	34.19	5.41	18.46
					24	75.2	8.65	29.51	6.92	23.61	9.83	33.53	7.17	24.48	10.12	34.54	5.97	20.38
					27	80.6	8.74	29.81	7.08	24.14	9.93	33.87	7.54	25.74	10.23	34.89	6.65	22.68
					31	87.8	8.82	30.11	7.41	25.29	10.03	34.21	7.92	27.03	10.33	35.24	7.23	24.67
	1860	1095	50	0.2	23	73.4	7.93	27.06	5.95	20.29	9.01	30.75	6.31	21.52	9.28	31.67	5.01	17.10
					24	75.2	8.01	27.34	6.41	21.87	9.10	31.06	6.65	22.68	9.38	31.99	5.53	18.88
					27	80.6	8.09	27.61	6.55	22.37	9.20	31.38	6.99	23.85	9.47	32.32	6.16	21.01
					31	87.8	8.17	27.89	6.87	23.43	9.29	31.69	7.34	25.04	9.57	32.64	6.70	22.85

DC Inverter U-match Air Conditioners Technical Sales Guide

Fan Speed	Air Flow Rate		ESP		Entering Air DBT		Outdoor Air Dry Bulb Temperature 110°F(43°C)											
							Indoor Air Wet Bulb Temperature °F(°C)											
					62°F(17°C)				67°F(19°C)				72°F(22°C)					
	m ³ /hr	cfm	Pa	in.wg	°C	°F	Total Capacity		Sensible Capacity		Total Capacity		Sensible Capacity		Total Capacity		Sensible Capacity	
						kW	Mbh	kW	Mbh	kW	Mbh	kW	Mbh	kW	Mbh	kW	Mbh	
Medium	2380	1401	0	0	23	73.4	8.60	29.33	6.45	22.00	9.77	33.33	6.84	23.33	10.06	34.33	5.43	18.54
					24	75.2	8.69	29.63	6.95	23.71	9.87	33.68	7.20	24.58	10.17	34.69	6.00	20.46
					27	80.6	8.77	29.93	7.11	24.25	9.97	34.02	7.58	25.85	10.27	35.04	6.67	22.77
					31	87.8	8.86	30.23	7.44	25.40	10.07	34.36	7.95	27.14	10.37	35.39	7.26	24.77
	2150	1265	25	0.1	23	73.4	8.11	27.67	6.08	20.76	9.22	31.45	6.45	22.01	9.49	32.39	5.13	17.49
					24	75.2	8.19	27.96	6.55	22.37	9.31	31.77	6.80	23.19	9.59	32.72	5.66	19.31
					27	80.6	8.28	28.24	6.70	22.87	9.41	32.09	7.15	24.39	9.69	33.05	6.30	21.48
					31	87.8	8.36	28.52	7.02	23.96	9.50	32.41	7.50	25.60	9.78	33.38	6.85	23.37
	2020	1189	37	0.15	23	73.4	7.71	26.29	5.78	19.72	8.76	29.88	6.13	20.91	9.02	30.77	4.87	16.62
					24	75.2	7.78	26.56	6.23	21.25	8.85	30.18	6.46	22.03	9.11	31.09	5.38	18.34
					27	80.6	7.86	26.83	6.37	21.73	8.93	30.49	6.79	23.17	9.20	31.40	5.98	20.41
					31	87.8	7.94	27.10	6.67	22.76	9.02	30.79	7.13	24.32	9.29	31.71	6.51	22.20
	1860	1095	50	0.2	23	73.4	7.14	24.35	5.35	18.27	8.11	27.67	5.68	19.37	8.35	28.50	4.51	15.39
					24	75.2	7.21	24.60	5.77	19.68	8.19	27.96	5.98	20.41	8.44	28.80	4.98	16.99
					27	80.6	7.28	24.85	5.90	20.13	8.28	28.24	6.29	21.46	8.52	29.09	5.54	18.91
					31	87.8	7.36	25.10	6.18	21.08	8.36	28.52	6.60	22.53	8.61	29.38	6.03	20.56

Fan Speed	Air Flow Rate		ESP		Entering Air DBT		Outdoor Air Dry Bulb Temperature 77°F(25°C)											
							Indoor Air Wet Bulb Temperature °F(°C)											
					62°F(17°C)				67°F(19°C)				72°F(22°C)					
	m ³ /hr	cfm	Pa	in.wg	°C	°F	Total Capacity		Sensible Capacity		Total Capacity		Sensible Capacity		Total Capacity		Sensible Capacity	
						kW	Mbh	kW	Mbh	kW	Mbh	kW	Mbh	kW	Mbh	kW	Mbh	
Low	2100	1236	0	0	23	73.4	9.96	33.97	7.47	25.47	11.31	38.60	7.92	27.02	11.65	39.76	6.29	21.47
					24	75.2	10.06	34.31	8.05	27.45	11.43	38.99	8.34	28.46	11.77	40.16	6.94	23.70
					27	80.6	10.16	34.66	8.23	28.07	11.54	39.39	8.77	29.93	11.89	40.57	7.73	26.37
					31	87.8	10.26	35.01	8.62	29.41	11.66	39.78	9.21	31.43	12.01	40.97	8.41	28.68
	1840	1083	25	0.1	23	73.4	9.39	32.04	7.04	24.03	10.67	36.41	7.47	25.49	10.99	37.51	5.94	20.25
					24	75.2	9.49	32.37	7.59	25.90	10.78	36.79	7.87	26.85	11.10	37.89	6.55	22.35
					27	80.6	9.58	32.70	7.76	26.49	10.89	37.16	8.28	28.24	11.22	38.27	7.29	24.88
					31	87.8	9.68	33.02	8.13	27.74	11.00	37.53	8.69	29.65	11.33	38.65	7.93	27.06
	1720	1012	37	0.15	23	73.4	8.92	30.44	6.69	22.83	10.14	34.59	7.10	24.22	10.44	35.63	5.64	19.24
					24	75.2	9.01	30.75	7.21	24.60	10.24	34.95	7.48	25.51	10.55	35.99	6.22	21.24
					27	80.6	9.10	31.06	7.37	25.16	10.35	35.30	7.86	26.83	10.66	36.36	6.93	23.63
					31	87.8	9.20	31.37	7.72	26.35	10.45	35.65	8.25	28.16	10.76	36.72	7.53	25.70
	1560	918	50	0.2	23	73.4	8.26	28.20	6.20	21.15	9.39	32.04	6.57	22.43	9.67	33.01	5.22	17.82
					24	75.2	8.35	28.49	6.68	22.79	9.49	32.37	6.93	23.63	9.77	33.34	5.77	19.67
					27	80.6	8.43	28.77	6.83	23.31	9.58	32.70	7.28	24.85	9.87	33.68	6.42	21.89
					31	87.8	8.52	29.06	7.15	24.41	9.68	33.02	7.65	26.09	9.97	34.02	6.98	23.81

Fan Speed	Air Flow Rate		ESP		Entering Air DBT		Outdoor Air Dry Bulb Temperature 95°F(35°C)											
							Indoor Air Wet Bulb Temperature °F(°C)											
							62°F(17°C)			67°F(19°C)			72°F(22°C)					
	m ³ /hr	cfm	Pa	in.wg	°C	°F	Total Capacity		Sensible Capacity		Total Capacity		Sensible Capacity		Total Capacity		Sensible Capacity	
						kW	Mbh	kW	Mbh	kW	Mbh	kW	Mbh	kW	Mbh	kW	Mbh	
Low	2100	1236	0	0	23	73.4	9.05	30.88	6.79	23.16	10.28	35.09	7.20	24.56	10.59	36.14	5.72	19.52
					24	75.2	9.14	31.19	7.31	24.96	10.39	35.45	7.58	25.88	10.70	36.51	6.31	21.54
					27	80.6	9.23	31.51	7.48	25.52	10.49	35.81	7.98	27.21	10.81	36.88	7.03	23.97
					31	87.8	9.33	31.82	7.83	26.73	10.60	36.16	8.37	28.57	10.92	37.25	7.64	26.07
	1840	1083	25	0.1	23	73.4	8.54	29.13	6.40	21.85	9.70	33.10	6.79	23.17	9.99	34.10	5.40	18.41
					24	75.2	8.62	29.43	6.90	23.54	9.80	33.44	7.15	24.41	10.10	34.44	5.96	20.32
					27	80.6	8.71	29.73	7.06	24.08	9.90	33.78	7.52	25.67	10.20	34.79	6.63	22.61
					31	87.8	8.80	30.02	7.39	25.22	10.00	34.12	7.90	26.95	10.30	35.14	7.21	24.60
	1720	1012	37	0.15	23	73.4	8.11	27.67	6.08	20.76	9.22	31.45	6.45	22.01	9.49	32.39	5.13	17.49
					24	75.2	8.19	27.96	6.55	22.37	9.31	31.77	6.80	23.19	9.59	32.72	5.66	19.31
					27	80.6	8.28	28.24	6.70	22.87	9.41	32.09	7.15	24.39	9.69	33.05	6.30	21.48
					31	87.8	8.36	28.52	7.02	23.96	9.50	32.41	7.50	25.60	9.78	33.38	6.85	23.37
	1560	918	50	0.2	23	73.4	7.51	25.64	5.63	19.23	8.54	29.13	5.98	20.39	8.79	30.00	4.75	16.20
					24	75.2	7.59	25.90	6.07	20.72	8.62	29.43	6.30	21.48	8.88	30.31	5.24	17.88
					27	80.6	7.67	26.16	6.21	21.19	8.71	29.73	6.62	22.59	8.97	30.62	5.83	19.90
					31	87.8	7.74	26.42	6.50	22.19	8.80	30.02	6.95	23.72	9.06	30.92	6.34	21.65

Fan Speed	Air Flow Rate		ESP		Entering Air DBT		Outdoor Air Dry Bulb Temperature 110°F(43°C)											
							Indoor Air Wet Bulb Temperature °F(°C)											
							62°F(17°C)			67°F(19°C)			72°F(22°C)					
	m ³ /hr	cfm	Pa	in.wg	°C	°F	Total Capacity		Sensible Capacity		Total Capacity		Sensible Capacity		Total Capacity		Sensible Capacity	
						kW	Mbh	kW	Mbh	kW	Mbh	kW	Mbh	kW	Mbh	kW	Mbh	
Low	2100	1236	0	0	23	73.4	8.15	27.79	6.11	20.84	9.26	31.58	6.48	22.11	9.53	32.53	5.15	17.57
					24	75.2	8.23	28.07	6.58	22.46	9.35	31.90	6.83	23.29	9.63	32.86	5.68	19.39
					27	80.6	8.31	28.36	6.73	22.97	9.44	32.22	7.18	24.49	9.73	33.19	6.32	21.57
					31	87.8	8.39	28.64	7.05	24.06	9.54	32.55	7.54	25.71	9.83	33.52	6.88	23.47
	1840	1083	25	0.1	23	73.4	7.68	26.22	5.76	19.66	8.73	29.79	6.11	20.86	8.99	30.69	4.86	16.57
					24	75.2	7.76	26.49	6.21	21.19	8.82	30.10	6.44	21.97	9.09	31.00	5.36	18.29
					27	80.6	7.84	26.75	6.35	21.67	8.91	30.40	6.77	23.10	9.18	31.31	5.97	20.35
					31	87.8	7.92	27.02	6.65	22.70	9.00	30.70	7.11	24.26	9.27	31.63	6.49	22.14
	1720	1012	37	0.15	23	73.4	7.30	24.91	5.47	18.68	8.30	28.30	5.81	19.81	8.54	29.15	4.61	15.74
					24	75.2	7.37	25.16	5.90	20.13	8.38	28.59	6.12	20.87	8.63	29.45	5.09	17.38
					27	80.6	7.45	25.42	6.03	20.59	8.46	28.88	6.43	21.95	8.72	29.75	5.67	19.34
					31	87.8	7.52	25.67	6.32	21.56	8.55	29.17	6.75	23.04	8.81	30.04	6.16	21.03
	1560	918	50	0.2	23	73.4	6.76	23.07	5.07	17.30	7.68	26.22	5.38	18.35	7.91	27.00	4.27	14.58
					24	75.2	6.83	23.31	5.46	18.65	7.76	26.49	5.67	19.33	8.00	27.28	4.72	16.10
					27	80.6	6.90	23.54	5.59	19.07	7.84	26.75	5.96	20.33	8.08	27.56	5.25	17.91
					31	87.8	6.97	23.78	5.85	19.97	7.92	27.02	6.26	21.35	8.16	27.83	5.71	19.48

DC Inverter U-match Air Conditioners Technical Sales Guide

GFH42K3FI:

Fan Speed	Air Flow Rate		ESP		Entering Air DBT		Outdoor Air Dry Bulb Temperature 77°F(25°C)											
							Indoor Air Wet Bulb Temperature °F(°C)											
	m ³ /hr cfm		Pa in.wg		°C °F		62°F(17°C)		67°F(19°C)		72°F(22°C)		72°F(22°C)					
							Total Capacity	Sensible Capacity	Total Capacity	Sensible Capacity	Total Capacity	Sensible Capacity	Total Capacity	Sensible Capacity				
						kW	Mbh	kW	Mbh	kW	Mbh	kW	Mbh	kW	Mbh	kW	Mbh	
High	2500	1471	0	0	23	73.4	11.87	40.49	8.90	30.36	13.48	46.01	9.44	32.20	13.89	47.39	7.50	25.59
					24	75.2	11.99	40.90	9.59	32.72	13.62	46.48	9.94	33.93	14.03	47.87	8.28	28.24
					27	80.6	12.11	41.31	9.81	33.46	13.76	46.95	10.46	35.68	14.17	48.35	9.21	31.43
					31	87.8	12.23	41.72	10.27	35.05	13.90	47.41	10.98	37.46	14.31	48.84	10.02	34.19
	2260	1330	25	0.1	23	73.4	11.19	38.19	8.40	28.65	12.72	43.40	8.90	30.38	13.10	44.70	7.08	24.14
					24	75.2	11.31	38.58	9.05	30.87	12.85	43.84	9.38	32.01	13.24	45.16	7.81	26.64
					27	80.6	11.42	38.97	9.25	31.57	12.98	44.29	9.86	33.66	13.37	45.62	8.69	29.65
					31	87.8	11.54	39.36	9.69	33.06	13.11	44.73	10.36	35.34	13.50	46.07	9.45	32.25
	2100	1236	37	0.15	23	73.4	10.63	36.28	7.98	27.21	12.08	41.23	8.46	28.86	12.45	42.47	6.72	22.93
					24	75.2	10.74	36.65	8.59	29.32	12.21	41.65	8.91	30.41	12.57	42.90	7.42	25.31
					27	80.6	10.85	37.02	8.79	29.99	12.33	42.07	9.37	31.98	12.70	43.34	8.26	28.17
					31	87.8	10.96	37.39	9.21	31.41	12.45	42.49	9.84	33.57	12.83	43.77	8.98	30.64
	1980	1165	50	0.2	23	73.4	9.85	33.61	7.39	25.21	11.19	38.19	7.84	26.74	11.53	39.34	6.23	21.24
					24	75.2	9.95	33.95	7.96	27.16	11.31	38.58	8.25	28.17	11.65	39.74	6.87	23.45
					27	80.6	10.05	34.30	8.14	27.78	11.42	38.97	8.68	29.62	11.77	40.14	7.65	26.09
					31	87.8	10.15	34.64	8.53	29.10	11.54	39.36	9.11	31.10	11.88	40.54	8.32	28.38

Fan Speed	Air Flow Rate		ESP		Entering Air DBT		Outdoor Air Dry Bulb Temperature 95°F(35°C)											
							Indoor Air Wet Bulb Temperature °F(°C)											
	m ³ /hr cfm		Pa in.wg		°C °F		62°F(17°C)		67°F(19°C)		72°F(22°C)		72°F(22°C)					
							Total Capacity	Sensible Capacity	Total Capacity	Sensible Capacity	Total Capacity	Sensible Capacity	Total Capacity	Sensible Capacity				
						kW	Mbh	kW	Mbh	kW	Mbh	kW	Mbh	kW	Mbh	kW	Mbh	
High	2500	1471	0	0	23	73.4	10.79	36.80	8.09	27.60	12.26	41.82	8.58	29.28	12.63	43.08	6.82	23.26
					24	75.2	10.90	37.18	8.72	29.74	12.38	42.25	9.04	30.84	12.75	43.52	7.53	25.68
					27	80.6	11.01	37.56	8.92	30.42	12.51	42.68	9.51	32.43	12.88	43.96	8.37	28.57
					31	87.8	11.12	37.93	9.34	31.86	12.63	43.10	9.98	34.05	13.01	44.40	9.11	31.08
	2260	1330	25	0.1	23	73.4	10.18	34.72	7.63	26.04	11.56	39.46	8.09	27.62	11.91	40.64	6.43	21.95
					24	75.2	10.28	35.08	8.22	28.06	11.68	39.86	8.53	29.10	12.03	41.05	7.10	24.22
					27	80.6	10.38	35.43	8.41	28.70	11.80	40.26	8.97	30.60	12.15	41.47	7.90	26.96
					31	87.8	10.49	35.78	8.81	30.06	11.92	40.66	9.42	32.12	12.28	41.88	8.59	29.32
	2100	1236	37	0.15	23	73.4	9.67	32.99	7.25	24.74	10.99	37.48	7.69	26.24	11.32	38.61	6.11	20.85
					24	75.2	9.77	33.32	7.81	26.66	11.10	37.87	8.10	27.64	11.43	39.00	6.74	23.01
					27	80.6	9.86	33.66	7.99	27.26	11.21	38.25	8.52	29.07	11.55	39.40	7.51	25.61
					31	87.8	9.96	34.00	8.37	28.56	11.32	38.63	8.94	30.52	11.66	39.79	8.16	27.85
	1980	1165	50	0.2	23	73.4	8.96	30.56	6.72	22.92	10.18	34.72	7.12	24.31	10.48	35.76	5.66	19.31
					24	75.2	9.05	30.87	7.24	24.69	10.28	35.08	7.50	25.61	10.59	36.13	6.25	21.32
					27	80.6	9.14	31.18	7.40	25.25	10.38	35.43	7.89	26.93	10.70	36.49	6.95	23.72
					31	87.8	9.23	31.49	7.75	26.45	10.49	35.78	8.29	28.27	10.80	36.86	7.56	25.80

Fan Speed	Air Flow Rate		ESP		Entering Air DBT		Outdoor Air Dry Bulb Temperature 110°F(43°C)											
							Indoor Air Wet Bulb Temperature °F(°C)											
	m ³ /hr cfm		Pa in.wg		°C °F		62°F(17°C)		67°F(19°C)		72°F(22°C)		72°F(22°C)					
							Total Capacity	Sensible Capacity	Total Capacity	Sensible Capacity	Total Capacity	Sensible Capacity	Total Capacity	Sensible Capacity				
						kW	Mbh	kW	Mbh	kW	Mbh	kW	Mbh	kW	Mbh	kW	Mbh	
High	2500	1471	0	0	23	73.4	9.71	33.12	7.28	24.84	11.03	37.64	7.72	26.35	11.36	38.77	6.14	20.94
					24	75.2	9.81	33.46	7.85	26.77	11.14	38.03	8.14	27.76	11.48	39.17	6.77	23.11
					27	80.6	9.91	33.80	8.02	27.38	11.26	38.41	8.56	29.19	11.59	39.56	7.54	25.72
					31	87.8	10.01	34.14	8.40	28.68	11.37	38.79	8.98	30.65	11.71	39.96	8.20	27.97
	2260	1330	25	0.1	23	73.4	9.16	31.25	6.87	23.44	10.41	35.51	7.29	24.86	10.72	36.58	5.79	19.75
					24	75.2	9.25	31.57	7.40	25.25	10.51	35.87	7.68	26.19	10.83	36.95	6.39	21.80
					27	80.6	9.35	31.89	7.57	25.83	10.62	36.24	8.07	27.54	10.94	37.32	7.11	24.26
					31	87.8	9.44	32.21	7.93	27.05	10.73	36.60	8.47	28.91	11.05	37.70	7.73	26.39
	2100	1236	37	0.15	23	73.4	8.70	29.69	6.53	22.27	9.89	33.74	6.92	23.61	10.18	34.75	5.50	18.76
					24	75.2	8.79	29.99	7.03	23.99	9.99	34.08	7.29	24.88	10.29	35.10	6.07	20.71
					27	80.6	8.88	30.29	7.19	24.54	10.09	34.42	7.67	26.16	10.39	35.46	6.75	23.05
					31	87.8	8.97	30.60	7.53	25.70	10.19	34.77	8.05	27.47	10.50	35.81	7.35	25.07
	1980	1165	50	0.2	23	73.4	8.06	27.50	6.04	20.62	9.16	31.25	6.41	21.87	9.43	32.19	5.09	17.38
					24	75.2	8.14	27.78	6.51	22.22	9.25	31.57	6.75	23.04	9.53	32.52	5.62	19.18
					27	80.6	8.22	28.06	6.66	22.73	9.35	31.89	7.10	24.23	9.63	32.84	6.26	21.35
					31	87.8	8.31	28.34	6.98	23.81	9.44	32.21	7.46	25.44	9.72	33.17	6.81	23.22

Fan Speed	Air Flow Rate		ESP		Entering Air DBT		Outdoor Air Dry Bulb Temperature 77°F(25°C)											
							Indoor Air Wet Bulb Temperature °F(°C)											
	m ³ /hr cfm		Pa in.wg		°C °F		62°F(17°C)		67°F(19°C)		72°F(22°C)		72°F(22°C)					
							Total Capacity	Sensible Capacity	Total Capacity	Sensible Capacity	Total Capacity	Sensible Capacity	Total Capacity	Sensible Capacity				
						kW	Mbh	kW	Mbh	kW	Mbh	kW	Mbh	kW	Mbh	kW	Mbh	
Medium	2380	1401	0	0	23	73.4	11.27	38.46	8.45	28.85	12.81	43.71	8.97	30.59	13.19	45.02	7.12	24.31
					24	75.2	11.39	38.85	9.11	31.08	12.94	44.15	9.45	32.23	13.33	45.48	7.86	26.83
					27	80.6	11.50	39.25	9.32	31.79	13.07	44.60	9.93	33.89	13.46	45.94	8.75	29.86
					31	87.8	11.62	39.64	9.76	33.30	13.20	45.04	10.43	35.58	13.60	46.40	9.52	32.48
	2150	1265	25	0.1	23	73.4	10.63	36.28	7.98	27.21	12.08	41.23	8.46	28.86	12.45	42.47	6.72	22.93
					24	75.2	10.74	36.65	8.59	29.32	12.21	41.65	8.91	30.41	12.57	42.90	7.42	25.31
					27	80.6	10.85	37.02	8.79	29.99	12.33	42.07	9.37	31.98	12.70	43.34	8.26	28.17
					31	87.8	10.96	37.39	9.21	31.41	12.45	42.49	9.84	33.57	12.83	43.77	8.98	30.64
	2020	1189	37	0.15	23	73.4	10.10	34.47	7.58	25.85	11.48	39.17	8.04	27.42	11.82	40.35	6.39	21.79
					24	75.2	10.21	34.82	8.16	27.86	11.60	39.57	8.47	28.89	11.95	40.76	7.05	24.05
					27	80.6	10.31	35.17	8.35	28.49	11.71	39.97	8.90	30.38	12.07	41.17	7.84	26.76
					31	87.8	10.41	35.53	8.75	29.84	11.83	40.37	9.35	31.89	12.19	41.58	8.53	29.11
	1860	1095	50	0.2	23	73.4	9.36	31.93	7.02	23.95	10.63	36.28	7.44	25.40	10.95	37.37	5.91	20.18
					24	75.2	9.45	32.26	7.56	25.80	10.74	36.65	7.84	26.76	11.07	37.75	6.53	22.27
					27	80.6	9.55	32.58	7.73	26.39	10.85	37.02	8.25	28.14	11.18	38.14	7.26	24.79
					31	87.8	9.64	32.91	8.10	27.64	10.96	37.39	8.66	29.54	11.29	38.52	7.90	26.96

DC Inverter U-match Air Conditioners Technical Sales Guide

Fan Speed	Air Flow Rate		ESP		Entering Air DBT		Outdoor Air Dry Bulb Temperature 95°F(35°C)											
							Indoor Air Wet Bulb Temperature °F(°C)											
					62°F(17°C)				67°F(19°C)				72°F(22°C)					
	m ³ /hr	cfm	Pa	in.wg	°C	°F	Total Capacity		Sensible Capacity		Total Capacity		Sensible Capacity		Total Capacity		Sensible Capacity	
						kW	Mbh	kW	Mbh	kW	Mbh	kW	Mbh	kW	Mbh	kW	Mbh	
Medium	2380	1401	0	0	23	73.4	10.25	34.96	7.69	26.22	11.64	39.73	8.15	27.81	11.99	40.92	6.48	22.10
					24	75.2	10.35	35.32	8.28	28.26	11.76	40.14	8.59	29.30	12.12	41.34	7.15	24.39
					27	80.6	10.46	35.68	8.47	28.90	11.88	40.54	9.03	30.81	12.24	41.76	7.96	27.14
					31	87.8	10.56	36.04	8.87	30.27	12.00	40.95	9.48	32.35	12.36	42.18	8.65	29.52
	2150	1265	25	0.1	23	73.4	9.67	32.99	7.25	24.74	10.99	37.48	7.69	26.24	11.32	38.61	6.11	20.85
					24	75.2	9.77	33.32	7.81	26.66	11.10	37.87	8.10	27.64	11.43	39.00	6.74	23.01
					27	80.6	9.86	33.66	7.99	27.26	11.21	38.25	8.52	29.07	11.55	39.40	7.51	25.61
					31	87.8	9.96	34.00	8.37	28.56	11.32	38.63	8.94	30.52	11.66	39.79	8.16	27.85
	2020	1189	37	0.15	23	73.4	9.18	31.34	6.89	23.50	10.44	35.61	7.31	24.93	10.75	36.68	5.80	19.81
					24	75.2	9.28	31.66	7.42	25.32	10.54	35.97	7.70	26.26	10.86	37.05	6.41	21.86
					27	80.6	9.37	31.98	7.59	25.90	10.65	36.34	8.09	27.62	10.97	37.43	7.13	24.33
					31	87.8	9.47	32.30	7.95	27.13	10.76	36.70	8.50	28.99	11.08	37.80	7.76	26.46
	1860	1095	50	0.2	23	73.4	8.51	29.03	6.38	21.77	9.67	32.99	6.77	23.09	9.96	33.98	5.38	18.35
					24	75.2	8.59	29.32	6.88	23.46	9.77	33.32	7.13	24.33	10.06	34.32	5.93	20.25
					27	80.6	8.68	29.62	7.03	23.99	9.86	33.66	7.50	25.58	10.16	34.67	6.60	22.53
					31	87.8	8.77	29.92	7.36	25.13	9.96	34.00	7.87	26.86	10.26	35.02	7.18	24.51

Fan Speed	Air Flow Rate		ESP		Entering Air DBT		Outdoor Air Dry Bulb Temperature 110°F(43°C)											
							Indoor Air Wet Bulb Temperature °F(°C)											
					62°F(17°C)				67°F(19°C)				72°F(22°C)					
	m ³ /hr	cfm	Pa	in.wg	°C	°F	Total Capacity		Sensible Capacity		Total Capacity		Sensible Capacity		Total Capacity		Sensible Capacity	
						kW	Mbh	kW	Mbh	kW	Mbh	kW	Mbh	kW	Mbh	kW	Mbh	
Medium	2380	1401	0	0	23	73.4	9.22	31.47	6.92	23.60	10.48	35.76	7.34	25.03	10.79	36.83	5.83	19.89
					24	75.2	9.32	31.79	7.45	25.43	10.59	36.12	7.73	26.37	10.91	37.21	6.43	21.95
					27	80.6	9.41	32.11	7.62	26.01	10.69	36.49	8.13	27.73	11.02	37.58	7.16	24.43
					31	87.8	9.51	32.43	7.98	27.24	10.80	36.85	8.53	29.11	11.13	37.96	7.79	26.57
	2150	1265	25	0.1	23	73.4	8.70	29.69	6.53	22.27	9.89	33.74	6.92	23.61	10.18	34.75	5.50	18.76
					24	75.2	8.79	29.99	7.03	23.99	9.99	34.08	7.29	24.88	10.29	35.10	6.07	20.71
					27	80.6	8.88	30.29	7.19	24.54	10.09	34.42	7.67	26.16	10.39	35.46	6.75	23.05
					31	87.8	8.97	30.60	7.53	25.70	10.19	34.77	8.05	27.47	10.50	35.81	7.35	25.07
	2020	1189	37	0.15	23	73.4	8.27	28.20	6.20	21.15	9.39	32.05	6.58	22.43	9.67	33.01	5.22	17.83
					24	75.2	8.35	28.49	6.68	22.79	9.49	32.38	6.93	23.63	9.77	33.35	5.77	19.67
					27	80.6	8.43	28.78	6.83	23.31	9.58	32.70	7.28	24.85	9.87	33.68	6.42	21.89
					31	87.8	8.52	29.07	7.16	24.42	9.68	33.03	7.65	26.09	9.97	34.02	6.98	23.81
	1860	1095	50	0.2	23	73.4	7.66	26.12	5.74	19.59	8.70	29.69	6.09	20.78	8.96	30.58	4.84	16.51
					24	75.2	7.73	26.39	6.19	21.11	8.79	29.99	6.42	21.89	9.05	30.89	5.34	18.22
					27	80.6	7.81	26.66	6.33	21.59	8.88	30.29	6.75	23.02	9.14	31.20	5.94	20.28
					31	87.8	7.89	26.92	6.63	22.62	8.97	30.60	7.08	24.17	9.24	31.51	6.47	22.06

Fan Speed	Air Flow Rate		ESP		Entering Air DBT		Outdoor Air Dry Bulb Temperature 77°F(25°C)												
							Indoor Air Wet Bulb Temperature °F(°C)												
							62°F(17°C)		67°F(19°C)		72°F(22°C)								
	m ³ /hr	cfm	Pa	in.wg	°C	°F	Total Capacity		Sensible Capacity		Total Capacity		Sensible Capacity		Total Capacity		Sensible Capacity		
						kW	Mbh	kW	Mbh	kW	Mbh	kW	Mbh	kW	Mbh	kW	Mbh	kW	Mbh
Low	2100	1236	0	0	23	73.4	10.68	36.44	8.01	27.33	12.14	41.41	8.49	28.98	12.50	42.65	6.75	23.03	
					24	75.2	10.79	36.81	8.63	29.45	12.26	41.83	8.95	30.53	12.63	43.08	7.45	25.42	
					27	80.6	10.90	37.18	8.83	30.12	12.38	42.25	9.41	32.11	12.75	43.52	8.29	28.29	
					31	87.8	11.01	37.55	9.24	31.54	12.51	42.67	9.88	33.71	12.88	43.95	9.02	30.77	
	1840	1083	25	0.1	23	73.4	10.07	34.37	7.56	25.78	11.45	39.06	8.01	27.34	11.79	40.23	6.37	21.73	
					24	75.2	10.18	34.73	8.14	27.78	11.57	39.46	8.44	28.81	11.91	40.64	7.03	23.98	
					27	80.6	10.28	35.08	8.33	28.41	11.68	39.86	8.88	30.29	12.03	41.05	7.82	26.69	
					31	87.8	10.38	35.43	8.72	29.76	11.80	40.26	9.32	31.80	12.15	41.47	8.51	29.03	
	1720	1012	37	0.15	23	73.4	9.57	32.66	7.18	24.49	10.88	37.11	7.61	25.98	11.20	38.22	6.05	20.64	
					24	75.2	9.67	32.99	7.73	26.39	10.99	37.49	8.02	27.37	11.32	38.61	6.68	22.78	
					27	80.6	9.77	33.32	7.91	26.99	11.10	37.87	8.43	28.78	11.43	39.00	7.43	25.35	
					31	87.8	9.86	33.66	8.29	28.27	11.21	38.24	8.86	30.21	11.55	39.39	8.08	27.57	
	1560	918	50	0.2	23	73.4	8.87	30.25	6.65	22.69	10.07	34.37	7.05	24.06	10.38	35.41	5.60	19.12	
					24	75.2	8.96	30.56	7.16	24.45	10.18	34.73	7.43	25.35	10.48	35.77	6.18	21.10	
					27	80.6	9.05	30.87	7.33	25.00	10.28	35.08	7.81	26.66	10.59	36.13	6.88	23.48	
					31	87.8	9.14	31.18	7.68	26.19	10.38	35.43	8.20	27.99	10.69	36.49	7.49	25.54	

Fan Speed	Air Flow Rate		ESP		Entering Air DBT		Outdoor Air Dry Bulb Temperature 95°F(35°C)												
							Indoor Air Wet Bulb Temperature °F(°C)												
							62°F(17°C)		67°F(19°C)		72°F(22°C)								
	m ³ /hr	cfm	Pa	in.wg	°C	°F	Total Capacity		Sensible Capacity		Total Capacity		Sensible Capacity		Total Capacity		Sensible Capacity		
						kW	Mbh	kW	Mbh	kW	Mbh	kW	Mbh	kW	Mbh	kW	Mbh	kW	Mbh
Low	2100	1236	0	0	23	73.4	9.71	33.12	7.28	24.84	11.03	37.64	7.72	26.35	11.36	38.77	6.14	20.94	
					24	75.2	9.81	33.46	7.85	26.77	11.14	38.03	8.14	27.76	11.48	39.17	6.77	23.11	
					27	80.6	9.91	33.80	8.02	27.38	11.26	38.41	8.56	29.19	11.59	39.56	7.54	25.72	
					31	87.8	10.01	34.14	8.40	28.68	11.37	38.79	8.98	30.65	11.71	39.96	8.20	27.97	
	1840	1083	25	0.1	23	73.4	9.16	31.25	6.87	23.44	10.41	35.51	7.29	24.86	10.72	36.58	5.79	19.75	
					24	75.2	9.25	31.57	7.40	25.25	10.51	35.87	7.68	26.19	10.83	36.95	6.39	21.80	
					27	80.6	9.35	31.89	7.57	25.83	10.62	36.24	8.07	27.54	10.94	37.32	7.11	24.26	
					31	87.8	9.44	32.21	7.93	27.05	10.73	36.60	8.47	28.91	11.05	37.70	7.73	26.39	
	1720	1012	37	0.15	23	73.4	8.70	29.69	6.53	22.27	9.89	33.74	6.92	23.61	10.18	34.75	5.50	18.76	
					24	75.2	8.79	29.99	7.03	23.99	9.99	34.08	7.29	24.88	10.29	35.10	6.07	20.71	
					27	80.6	8.88	30.29	7.19	24.54	10.09	34.42	7.67	26.16	10.39	35.46	6.75	23.05	
					31	87.8	8.97	30.60	7.53	25.70	10.19	34.77	8.05	27.47	10.50	35.81	7.35	25.07	
	1560	918	50	0.2	23	73.4	8.06	27.50	6.04	20.62	9.16	31.25	6.41	21.87	9.43	32.19	5.09	17.38	
					24	75.2	8.14	27.78	6.51	22.22	9.25	31.57	6.75	23.04	9.53	32.52	5.62	19.18	
					27	80.6	8.22	28.06	6.66	22.73	9.35	31.89	7.10	24.23	9.63	32.84	6.26	21.35	
					31	87.8	8.31	28.34	6.98	23.81	9.44	32.21	7.46	25.44	9.72	33.17	6.81	23.22	

DC Inverter U-match Air Conditioners Technical Sales Guide

Fan Speed	Air Flow Rate		ESP		Entering Air DBT		Outdoor Air Dry Bulb Temperature 110°F(43°C)											
							Indoor Air Wet Bulb Temperature °F(°C)											
					62°F(17°C)				67°F(19°C)				72°F(22°C)					
	m³/hr	cfm	Pa	in.wg	°C	°F	Total Capacity		Sensible Capacity		Total Capacity		Sensible Capacity		Total Capacity		Sensible Capacity	
						kW	Mbh	kW	Mbh	kW	Mbh	kW	Mbh	kW	Mbh	kW	Mbh	
Low	2100	1236	0	0	23	73.4	8.74	29.81	6.55	22.36	9.93	33.88	6.95	23.71	10.23	34.89	5.52	18.84
					24	75.2	8.83	30.12	7.06	24.09	10.03	34.22	7.32	24.98	10.33	35.25	6.10	20.80
					27	80.6	8.92	30.42	7.22	24.64	10.13	34.57	7.70	26.27	10.44	35.61	6.78	23.14
					31	87.8	9.00	30.72	7.56	25.81	10.23	34.91	8.08	27.58	10.54	35.96	7.38	25.17
	1840	1083	25	0.1	23	73.4	8.24	28.12	6.18	21.09	9.37	31.96	6.56	22.37	9.65	32.92	5.21	17.78
					24	75.2	8.33	28.41	6.66	22.73	9.46	32.29	6.91	23.57	9.75	33.25	5.75	19.62
					27	80.6	8.41	28.70	6.81	23.25	9.56	32.61	7.26	24.79	9.84	33.59	6.40	21.83
					31	87.8	8.50	28.99	7.14	24.35	9.65	32.94	7.63	26.02	9.94	33.93	6.96	23.75
	1720	1012	37	0.15	23	73.4	7.83	26.72	5.87	20.04	8.90	30.36	6.23	21.25	9.17	31.27	4.95	16.89
					24	75.2	7.91	26.99	6.33	21.59	8.99	30.67	6.56	22.39	9.26	31.59	5.46	18.64
					27	80.6	7.99	27.26	6.47	22.08	9.08	30.98	6.90	23.55	9.35	31.91	6.08	20.74
					31	87.8	8.07	27.54	6.78	23.13	9.17	31.29	7.25	24.72	9.45	32.23	6.61	22.56
	1560	918	50	0.2	23	73.4	7.25	24.75	5.44	18.56	8.24	28.12	5.77	19.69	8.49	28.97	4.58	15.64
					24	75.2	7.33	25.00	5.86	20.00	8.33	28.41	6.08	20.74	8.58	29.26	5.06	17.27
					27	80.6	7.40	25.25	6.00	20.46	8.41	28.70	6.39	21.81	8.66	29.56	5.63	19.21
					31	87.8	7.48	25.51	6.28	21.43	8.50	28.99	6.71	22.90	8.75	29.86	6.13	20.90

GFH48K3FI:

Fan Speed	Air Flow Rate		ESP		Entering Air DBT		Outdoor Air Dry Bulb Temperature 77°F(25°C)											
							Indoor Air Wet Bulb Temperature °F(°C)											
					62°F(17°C)				67°F(19°C)				72°F(22°C)					
	m³/hr	cfm	Pa	in.wg	°C	°F	Total Capacity		Sensible Capacity		Total Capacity		Sensible Capacity		Total Capacity		Sensible Capacity	
						kW	Mbh	kW	Mbh	kW	Mbh	kW	Mbh	kW	Mbh	kW	Mbh	
High	2800	1648	25	0.1	23	73.4	14.98	51.12	11.24	38.34	17.03	58.09	11.92	40.66	17.54	59.84	9.47	32.31
					24	75.2	15.14	51.64	12.11	41.31	17.20	58.69	12.56	42.84	17.72	60.45	10.45	35.66
					27	80.6	15.29	52.16	12.38	42.25	17.37	59.28	13.20	45.05	17.89	61.06	11.63	39.69
					31	87.8	15.44	52.69	12.97	44.26	17.55	59.87	13.86	47.30	18.07	61.67	12.65	43.17
	2580	1519	37	0.15	23	73.4	14.13	48.23	10.60	36.17	16.06	54.80	11.24	38.36	16.54	56.45	8.93	30.48
					24	75.2	14.28	48.72	11.42	38.98	16.23	55.36	11.85	40.42	16.71	57.02	9.86	33.64
					27	80.6	14.42	49.21	11.68	39.86	16.39	55.92	12.46	42.50	16.88	57.60	10.97	37.44
					31	87.8	14.57	49.70	12.24	41.75	16.55	56.48	13.08	44.62	17.05	58.18	11.94	40.72
	2400	1413	50	0.2	23	73.4	13.43	45.82	10.07	34.36	15.26	52.06	10.68	36.44	15.72	53.63	8.49	28.96
					24	75.2	13.57	46.28	10.85	37.03	15.41	52.60	11.25	38.39	15.88	54.17	9.37	31.96
					27	80.6	13.70	46.75	11.10	37.87	15.57	53.13	11.83	40.38	16.04	54.72	10.42	35.57
					31	87.8	13.84	47.22	11.62	39.66	15.73	53.66	12.42	42.39	16.20	55.27	11.34	38.69
	2100	1236	70	0.28	23	73.4	12.44	42.44	9.33	31.83	14.13	48.23	9.89	33.76	14.56	49.67	7.86	26.82
					24	75.2	12.57	42.87	10.05	34.30	14.28	48.72	10.42	35.57	14.71	50.18	8.68	29.61
					27	80.6	12.69	43.31	10.28	35.08	14.42	49.21	10.96	37.40	14.86	50.69	9.66	32.95
					31	87.8	12.82	43.74	10.77	36.74	14.57	49.70	11.51	39.27	15.00	51.20	10.50	35.84

Fan Speed	Air Flow Rate		ESP		Entering Air DBT		Outdoor Air Dry Bulb Temperature 95°F(35°C)											
							Indoor Air Wet Bulb Temperature °F(°C)											
					62°F(17°C)				67°F(19°C)				72°F(22°C)					
	m ³ /hr	cfm	Pa	in.wg	°C	°F	Total Capacity		Sensible Capacity		Total Capacity		Sensible Capacity		Total Capacity		Sensible Capacity	
						kW	Mbh	kW	Mbh	kW	Mbh	kW	Mbh	kW	Mbh	kW	Mbh	
High	2800	1648	25	0.1	23	73.4	13.62	46.47	10.22	34.86	15.48	52.81	10.83	36.97	15.94	54.40	8.61	29.37
					24	75.2	13.76	46.95	11.01	37.56	15.64	53.35	11.41	38.95	16.11	54.95	9.50	32.42
					27	80.6	13.90	47.42	11.26	38.41	15.79	53.89	12.00	40.96	16.27	55.51	10.57	36.08
					31	87.8	14.04	47.90	11.79	40.23	15.95	54.43	12.60	43.00	16.43	56.06	11.50	39.24
	2580	1519	37	0.15	23	73.4	12.85	43.84	9.64	32.88	14.60	49.82	10.22	34.88	15.04	51.32	8.12	27.71
					24	75.2	12.98	44.29	10.38	35.43	14.75	50.33	10.77	36.74	15.19	51.84	8.96	30.59
					27	80.6	13.11	44.74	10.62	36.24	14.90	50.84	11.32	38.64	15.35	52.36	9.98	34.04
					31	87.8	13.24	45.19	11.12	37.96	15.05	51.35	11.89	40.56	15.50	52.89	10.85	37.02
	2400	1413	50	0.2	23	73.4	12.21	41.65	9.16	31.24	13.87	47.33	9.71	33.13	14.29	48.75	7.72	26.33
					24	75.2	12.33	42.08	9.87	33.66	14.01	47.81	10.23	34.90	14.43	49.25	8.52	29.06
					27	80.6	12.46	42.50	10.09	34.43	14.16	48.30	10.76	36.71	14.58	49.75	9.48	32.33
					31	87.8	12.58	42.93	10.57	36.06	14.30	48.78	11.29	38.54	14.73	50.24	10.31	35.17
	2100	1236	70	0.28	23	73.4	11.31	38.58	8.48	28.94	12.85	43.84	8.99	30.69	13.24	45.16	7.15	24.39
					24	75.2	11.42	38.98	9.14	31.18	12.98	44.29	9.48	32.33	13.37	45.62	7.89	26.92
					27	80.6	11.54	39.37	9.35	31.89	13.11	44.74	9.97	34.00	13.51	46.08	8.78	29.95
					31	87.8	11.65	39.76	9.79	33.40	13.24	45.19	10.46	35.70	13.64	46.54	9.55	32.58

Fan Speed	Air Flow Rate		ESP		Entering Air DBT		Outdoor Air Dry Bulb Temperature 110°F(43°C)											
							Indoor Air Wet Bulb Temperature °F(°C)											
					62°F(17°C)				67°F(19°C)				72°F(22°C)					
	m ³ /hr	cfm	Pa	in.wg	°C	°F	Total Capacity		Sensible Capacity		Total Capacity		Sensible Capacity		Total Capacity		Sensible Capacity	
						kW	Mbh	kW	Mbh	kW	Mbh	kW	Mbh	kW	Mbh	kW	Mbh	
High	2800	1648	25	0.1	23	73.4	12.26	41.83	9.19	31.37	13.93	47.53	9.75	33.27	14.35	48.96	7.75	26.44
					24	75.2	12.38	42.25	9.91	33.80	14.07	48.02	10.27	35.05	14.49	49.46	8.55	29.18
					27	80.6	12.51	42.68	10.13	34.57	14.21	48.50	10.80	36.86	14.64	49.96	9.52	32.47
					31	87.8	12.63	43.11	10.61	36.21	14.36	48.99	11.34	38.70	14.79	50.45	10.35	35.32
	2580	1519	37	0.15	23	73.4	11.56	39.46	8.67	29.59	13.14	44.84	9.20	31.39	13.54	46.19	7.31	24.94
					24	75.2	11.68	39.86	9.35	31.89	13.28	45.30	9.69	33.07	13.67	46.66	8.07	27.53
					27	80.6	11.80	40.26	9.56	32.61	13.41	45.75	10.19	34.77	13.81	47.13	8.98	30.63
					31	87.8	11.92	40.67	10.01	34.16	13.54	46.21	10.70	36.51	13.95	47.60	9.77	33.32
	2400	1413	50	0.2	23	73.4	10.99	37.49	8.24	28.11	12.48	42.60	8.74	29.82	12.86	43.88	6.94	23.69
					24	75.2	11.10	37.87	8.88	30.29	12.61	43.03	9.21	31.41	12.99	44.32	7.66	26.15
					27	80.6	11.21	38.25	9.08	30.98	12.74	43.47	9.68	33.04	13.12	44.77	8.53	29.10
					31	87.8	11.32	38.63	9.51	32.45	12.87	43.90	10.16	34.68	13.25	45.22	9.28	31.65
	2100	1236	70	0.28	23	73.4	10.18	34.72	7.63	26.04	11.56	39.46	8.10	27.62	11.91	40.64	6.43	21.95
					24	75.2	10.28	35.08	8.22	28.06	11.68	39.86	8.53	29.10	12.03	41.06	7.10	24.22
					27	80.6	10.38	35.43	8.41	28.70	11.80	40.26	8.97	30.60	12.15	41.47	7.90	26.96
					31	87.8	10.49	35.79	8.81	30.06	11.92	40.67	9.42	32.13	12.28	41.89	8.59	29.32

DC Inverter U-match Air Conditioners Technical Sales Guide

Fan Speed	Air Flow Rate		ESP		Entering Air DBT		Outdoor Air Dry Bulb Temperature 77°F(25°C)											
							Indoor Air Wet Bulb Temperature °F(°C)											
					62°F(17°C)				67°F(19°C)				72°F(22°C)					
	m ³ /hr	cfm	Pa	in.wg	°C	°F	Total Capacity		Sensible Capacity		Total Capacity		Sensible Capacity		Total Capacity		Sensible Capacity	
						kW	Mbh	kW	Mbh	kW	Mbh	kW	Mbh	kW	Mbh	kW	Mbh	
Medium	2680	1577	25	0.1	23	73.4	14.23	48.57	10.68	36.42	16.17	55.19	11.32	38.63	16.66	56.84	9.00	30.70
					24	75.2	14.38	49.06	11.50	39.25	16.34	55.75	11.93	40.70	16.83	57.42	9.93	33.88
					27	80.6	14.52	49.56	11.76	40.14	16.50	56.31	12.54	42.80	17.00	58.00	11.05	37.70
					31	87.8	14.67	50.05	12.32	42.04	16.67	56.88	13.17	44.93	17.17	58.58	12.02	41.01
	2500	1471	37	0.15	23	73.4	13.43	45.82	10.07	34.36	15.26	52.06	10.68	36.44	15.72	53.63	8.49	28.96
					24	75.2	13.57	46.28	10.85	37.03	15.41	52.60	11.25	38.39	15.88	54.17	9.37	31.96
					27	80.6	13.70	46.75	11.10	37.87	15.57	53.13	11.83	40.38	16.04	54.72	10.42	35.57
					31	87.8	13.84	47.22	11.62	39.66	15.73	53.66	12.42	42.39	16.20	55.27	11.34	38.69
	2300	1354	50	0.2	23	73.4	12.76	43.53	9.57	32.64	14.50	49.46	10.15	34.62	14.93	50.94	8.06	27.51
					24	75.2	12.89	43.97	10.31	35.18	14.64	49.97	10.69	36.47	15.08	51.46	8.90	30.36
					27	80.6	13.02	44.41	10.54	35.98	14.79	50.47	11.24	38.36	15.24	51.98	9.90	33.79
					31	87.8	13.15	44.86	11.04	37.68	14.94	50.97	11.80	40.27	15.39	52.50	10.77	36.75
	2000	1177	70	0.28	23	73.4	11.82	40.32	8.86	30.24	13.43	45.82	9.40	32.07	13.83	47.19	7.47	25.48
					24	75.2	11.94	40.73	9.55	32.58	13.57	46.28	9.90	33.79	13.97	47.67	8.24	28.13
					27	80.6	12.06	41.14	9.77	33.32	13.70	46.75	10.41	35.53	14.11	48.15	9.17	31.30
					31	87.8	12.18	41.55	10.23	34.90	13.84	47.22	10.93	37.30	14.25	48.64	9.98	34.04

Fan Speed	Air Flow Rate		ESP		Entering Air DBT		Outdoor Air Dry Bulb Temperature 95°F(35°C)											
							Indoor Air Wet Bulb Temperature °F(°C)											
					62°F(17°C)				67°F(19°C)				72°F(22°C)					
	m ³ /hr	cfm	Pa	in.wg	°C	°F	Total Capacity		Sensible Capacity		Total Capacity		Sensible Capacity		Total Capacity		Sensible Capacity	
						kW	Mbh	kW	Mbh	kW	Mbh	kW	Mbh	kW	Mbh	kW	Mbh	
Medium	2680	1577	25	0.1	23	73.4	12.94	44.15	9.70	33.11	14.70	50.17	10.29	35.12	15.15	51.68	8.18	27.90
					24	75.2	13.07	44.60	10.46	35.68	14.85	50.68	10.84	37.00	15.30	52.20	9.03	30.80
					27	80.6	13.20	45.05	10.70	36.49	15.00	51.19	11.40	38.91	15.45	52.73	10.05	34.27
					31	87.8	13.34	45.50	11.20	38.22	15.15	51.71	11.97	40.85	15.61	53.26	10.93	37.28
	2500	1471	37	0.15	23	73.4	12.21	41.65	9.16	31.24	13.87	47.33	9.71	33.13	14.29	48.75	7.72	26.33
					24	75.2	12.33	42.08	9.87	33.66	14.01	47.81	10.23	34.90	14.43	49.25	8.52	29.06
					27	80.6	12.46	42.50	10.09	34.43	14.16	48.30	10.76	36.71	14.58	49.75	9.48	32.33
					31	87.8	12.58	42.93	10.57	36.06	14.30	48.78	11.29	38.54	14.73	50.24	10.31	35.17
	2300	1354	50	0.2	23	73.4	11.60	39.57	8.70	29.68	13.18	44.96	9.22	31.48	13.57	46.31	7.33	25.01
					24	75.2	11.72	39.97	9.37	31.98	13.31	45.42	9.72	33.16	13.71	46.79	8.09	27.60
					27	80.6	11.83	40.38	9.59	32.70	13.45	45.88	10.22	34.87	13.85	47.26	9.00	30.72
					31	87.8	11.95	40.78	10.04	34.26	13.58	46.34	10.73	36.61	13.99	47.73	9.79	33.41
	2000	1177	70	0.28	23	73.4	10.74	36.65	8.06	27.49	12.21	41.65	8.55	29.16	12.57	42.90	6.79	23.17
					24	75.2	10.85	37.03	8.68	29.62	12.33	42.08	9.00	30.72	12.70	43.34	7.49	25.57
					27	80.6	10.96	37.40	8.88	30.29	12.46	42.50	9.47	32.30	12.83	43.78	8.34	28.45
					31	87.8	11.07	37.78	9.30	31.73	12.58	42.93	9.94	33.91	12.96	44.21	9.07	30.95

Fan Speed	Air Flow Rate		ESP		Entering Air DBT		Outdoor Air Dry Bulb Temperature 110°F(43°C)											
							Indoor Air Wet Bulb Temperature °F(°C)											
							62°F(17°C)				67°F(19°C)				72°F(22°C)			
							Total Capacity		Sensible Capacity		Total Capacity		Sensible Capacity		Total Capacity		Sensible Capacity	
m ³ /hr	cfm	Pa	in.wg	°C	°F	kW	Mbh	kW	Mbh	kW	Mbh	kW	Mbh	kW	Mbh	kW	Mbh	
Medium	2680	1577	25	0.1	23	73.4	11.65	39.74	8.73	29.80	13.23	45.15	9.26	31.61	13.63	46.51	7.36	25.11
					24	75.2	11.76	40.14	9.41	32.11	13.37	45.61	9.76	33.30	13.77	46.98	8.12	27.72
					27	80.6	11.88	40.55	9.63	32.84	13.50	46.08	10.26	35.02	13.91	47.46	9.04	30.85
					31	87.8	12.00	40.95	10.08	34.40	13.64	46.54	10.77	36.76	14.05	47.93	9.83	33.55
	2500	1471	37	0.15	23	73.4	10.99	37.49	8.24	28.11	12.48	42.60	8.74	29.82	12.86	43.88	6.94	23.69
					24	75.2	11.10	37.87	8.88	30.29	12.61	43.03	9.21	31.41	12.99	44.32	7.66	26.15
					27	80.6	11.21	38.25	9.08	30.98	12.74	43.47	9.68	33.04	13.12	44.77	8.53	29.10
					31	87.8	11.32	38.63	9.51	32.45	12.87	43.90	10.16	34.68	13.25	45.22	9.28	31.65
	2300	1354	50	0.2	23	73.4	10.44	35.61	7.83	26.71	11.86	40.47	8.30	28.33	12.22	41.68	6.60	22.51
					24	75.2	10.54	35.98	8.43	28.78	11.98	40.88	8.75	29.84	12.34	42.11	7.28	24.84
					27	80.6	10.65	36.34	8.63	29.43	12.10	41.29	9.20	31.38	12.47	42.53	8.10	27.65
					31	87.8	10.76	36.70	9.04	30.83	12.22	41.71	9.66	32.95	12.59	42.96	8.81	30.07
2000	1177	70	0.28	23	73.4	9.67	32.99	7.25	24.74	10.99	37.49	7.69	26.24	11.32	38.61	6.11	20.85	
				24	75.2	9.77	33.32	7.81	26.66	11.10	37.87	8.10	27.64	11.43	39.00	6.74	23.01	
				27	80.6	9.87	33.66	7.99	27.27	11.21	38.25	8.52	29.07	11.55	39.40	7.51	25.61	
				31	87.8	9.96	34.00	8.37	28.56	11.32	38.63	8.95	30.52	11.66	39.79	8.16	27.85	

Fan Speed	Air Flow Rate		ESP		Entering Air DBT		Outdoor Air Dry Bulb Temperature 77°F(25°C)											
							Indoor Air Wet Bulb Temperature °F(°C)											
							62°F(17°C)				67°F(19°C)				72°F(22°C)			
							Total Capacity		Sensible Capacity		Total Capacity		Sensible Capacity		Total Capacity		Sensible Capacity	
m ³ /hr	cfm	Pa	in.wg	°C	°F	kW	Mbh	kW	Mbh	kW	Mbh	kW	Mbh	kW	Mbh	kW	Mbh	
Low	2420	1424	25	0.1	23	73.4	13.48	46.01	10.11	34.51	15.32	52.28	10.73	36.60	15.78	53.85	8.52	29.08
					24	75.2	13.62	46.48	10.90	37.18	15.48	52.82	11.30	38.56	15.94	54.40	9.41	32.10
					27	80.6	13.76	46.95	11.15	38.03	15.64	53.35	11.88	40.55	16.11	54.95	10.47	35.72
					31	87.8	13.90	47.42	11.67	39.83	15.79	53.88	12.48	42.57	16.27	55.50	11.39	38.85
	2250	1324	37	0.15	23	73.4	12.72	43.40	9.54	32.55	14.46	49.32	10.12	34.53	14.89	50.80	8.04	27.43
					24	75.2	12.85	43.85	10.28	35.08	14.60	49.83	10.66	36.37	15.04	51.32	8.87	30.28
					27	80.6	12.98	44.29	10.51	35.88	14.75	50.33	11.21	38.25	15.19	51.84	9.88	33.70
					31	87.8	13.11	44.73	11.01	37.58	14.90	50.83	11.77	40.16	15.35	52.36	10.74	36.65
	2050	1207	50	0.2	23	73.4	12.09	41.23	9.06	30.93	13.73	46.86	9.61	32.80	14.15	48.26	7.64	26.06
					24	75.2	12.21	41.66	9.77	33.32	13.87	47.34	10.13	34.56	14.29	48.76	8.43	28.77
					27	80.6	12.33	42.08	9.99	34.08	14.01	47.81	10.65	36.34	14.43	49.25	9.38	32.01
					31	87.8	12.46	42.50	10.46	35.70	14.15	48.29	11.18	38.15	14.58	49.74	10.20	34.82
1750	1030	70	0.28	23	73.4	11.19	38.20	8.40	28.65	12.72	43.40	8.90	30.38	13.10	44.71	7.08	24.14	
				24	75.2	11.31	38.59	9.05	30.87	12.85	43.85	9.38	32.01	13.24	45.16	7.81	26.65	
				27	80.6	11.42	38.98	9.25	31.57	12.98	44.29	9.87	33.66	13.37	45.62	8.69	29.65	
				31	87.8	11.54	39.37	9.69	33.07	13.11	44.73	10.36	35.34	13.50	46.08	9.45	32.25	

DC Inverter U-match Air Conditioners Technical Sales Guide

Fan Speed	Air Flow Rate		ESP		Entering Air DBT		Outdoor Air Dry Bulb Temperature 95°F(35°C)											
							Indoor Air Wet Bulb Temperature °F(°C)											
					62°F(17°C)		67°F(19°C)				72°F(22°C)							
	m ³ /hr	cfm	Pa	in.wg	°C	°F	Total Capacity		Sensible Capacity		Total Capacity		Sensible Capacity		Total Capacity		Sensible Capacity	
						kW	Mbh	kW	Mbh	kW	Mbh	kW	Mbh	kW	Mbh	kW	Mbh	
Low	2420	1424	25	0.1	23	73.4	12.26	41.83	9.19	31.37	13.93	47.53	9.75	33.27	14.35	48.96	7.75	26.44
					24	75.2	12.38	42.25	9.91	33.80	14.07	48.02	10.27	35.05	14.49	49.46	8.55	29.18
					27	80.6	12.51	42.68	10.13	34.57	14.21	48.50	10.80	36.86	14.64	49.96	9.52	32.47
					31	87.8	12.63	43.11	10.61	36.21	14.36	48.99	11.34	38.70	14.79	50.45	10.35	35.32
	2250	1324	37	0.15	23	73.4	11.56	39.46	8.67	29.59	13.14	44.84	9.20	31.39	13.54	46.19	7.31	24.94
					24	75.2	11.68	39.86	9.35	31.89	13.28	45.30	9.69	33.07	13.67	46.66	8.07	27.53
					27	80.6	11.80	40.26	9.56	32.61	13.41	45.75	10.19	34.77	13.81	47.13	8.98	30.63
					31	87.8	11.92	40.67	10.01	34.16	13.54	46.21	10.70	36.51	13.95	47.60	9.77	33.32
	2050	1207	50	0.2	23	73.4	10.99	37.49	8.24	28.11	12.48	42.60	8.74	29.82	12.86	43.88	6.94	23.69
					24	75.2	11.10	37.87	8.88	30.29	12.61	43.03	9.21	31.41	12.99	44.32	7.66	26.15
					27	80.6	11.21	38.25	9.08	30.98	12.74	43.47	9.68	33.04	13.12	44.77	8.53	29.10
					31	87.8	11.32	38.63	9.51	32.45	12.87	43.90	10.16	34.68	13.25	45.22	9.28	31.65
	1750	1030	70	0.28	23	73.4	10.18	34.72	7.63	26.04	11.56	39.46	8.10	27.62	11.91	40.64	6.43	21.95
					24	75.2	10.28	35.08	8.22	28.06	11.68	39.86	8.53	29.10	12.03	41.06	7.10	24.22
					27	80.6	10.38	35.43	8.41	28.70	11.80	40.26	8.97	30.60	12.15	41.47	7.90	26.96
					31	87.8	10.49	35.79	8.81	30.06	11.92	40.67	9.42	32.13	12.28	41.89	8.59	29.32

Fan Speed	Air Flow Rate		ESP		Entering Air DBT		Outdoor Air Dry Bulb Temperature 110°F(43°C)											
							Indoor Air Wet Bulb Temperature °F(°C)											
					62°F(17°C)		67°F(19°C)				72°F(22°C)							
	m ³ /hr	cfm	Pa	in.wg	°C	°F	Total Capacity		Sensible Capacity		Total Capacity		Sensible Capacity		Total Capacity		Sensible Capacity	
						kW	Mbh	kW	Mbh	kW	Mbh	kW	Mbh	kW	Mbh	kW	Mbh	
Low	2420	1424	25	0.1	23	73.4	11.03	37.64	8.27	28.23	12.54	42.78	8.78	29.94	12.91	44.06	6.97	23.79
					24	75.2	11.15	38.03	8.92	30.42	12.67	43.21	9.25	31.55	13.05	44.51	7.70	26.26
					27	80.6	11.26	38.41	9.12	31.11	12.79	43.65	9.72	33.17	13.18	44.96	8.57	29.22
					31	87.8	11.37	38.80	9.55	32.59	12.92	44.09	10.21	34.83	13.31	45.41	9.32	31.79
	2250	1324	37	0.15	23	73.4	10.41	35.51	7.81	26.63	11.83	40.36	8.28	28.25	12.18	41.57	6.58	22.45
					24	75.2	10.51	35.88	8.41	28.70	11.95	40.77	8.72	29.76	12.31	41.99	7.26	24.77
					27	80.6	10.62	36.24	8.60	29.35	12.07	41.18	9.17	31.30	12.43	42.41	8.08	27.57
					31	87.8	10.73	36.60	9.01	30.74	12.19	41.59	9.63	32.86	12.56	42.84	8.79	29.99
	2050	1207	50	0.2	23	73.4	9.89	33.74	7.42	25.30	11.24	38.34	7.87	26.84	11.57	39.49	6.25	21.32
					24	75.2	9.99	34.08	7.99	27.27	11.35	38.73	8.29	28.27	11.69	39.89	6.90	23.54
					27	80.6	10.09	34.43	8.17	27.89	11.47	39.12	8.71	29.73	11.81	40.29	7.68	26.19
					31	87.8	10.19	34.77	8.56	29.21	11.58	39.51	9.15	31.21	11.93	40.70	8.35	28.49
	1750	1030	70	0.28	23	73.4	9.16	31.25	6.87	23.44	10.41	35.51	7.29	24.86	10.72	36.58	5.79	19.75
					24	75.2	9.25	31.57	7.40	25.26	10.51	35.88	7.68	26.19	10.83	36.95	6.39	21.80
					27	80.6	9.35	31.89	7.57	25.83	10.62	36.24	8.07	27.54	10.94	37.33	7.11	24.26
					31	87.8	9.44	32.21	7.93	27.05	10.73	36.60	8.47	28.91	11.05	37.70	7.73	26.39

DC Inverter U-match Air Conditioners Technical Sales Guide

Fan Speed	Air Flow Rate		ESP		Entering Air DBT		Outdoor Air Dry Bulb Temperature 110°F(43°C)													
							Indoor Air Wet Bulb Temperature °F(°C)													
			62°F(17°C)				67°F(19°C)				72°F(22°C)									
	m ³ /hr	cfm	Pa	in.wg	°C	°F	Total Capacity		Sensible Capacity		Total Capacity		Sensible Capacity		Total Capacity		Sensible Capacity			
						kW	Mbh	kW	Mbh	kW	Mbh	kW	Mbh	kW	Mbh	kW	Mbh	kW	Mbh	
High	3380	1989	25	0.1	23	73.4	14.48	49.41	10.86	37.05	16.45	56.14	11.52	39.30	16.95	57.83	9.15	31.23		
					24	75.2	14.63	49.91	11.70	39.93	16.62	56.72	12.13	41.40	17.12	58.42	10.10	34.47		
					27	80.6	14.78	50.41	11.97	40.84	16.79	57.29	12.76	43.54	17.29	59.01	11.24	38.35		
					31	87.8	14.92	50.92	12.54	42.77	16.96	57.86	13.40	45.71	17.47	59.60	12.23	41.72		
	3200	1883	37	0.15	23	73.4	13.66	46.61	10.25	34.96	15.52	52.97	10.87	37.08	15.99	54.55	8.63	29.46		
					24	75.2	13.80	47.08	11.04	37.67	15.68	53.51	11.45	39.06	16.15	55.11	9.53	32.52		
					27	80.6	13.94	47.56	11.29	38.52	15.84	54.05	12.04	41.08	16.32	55.67	10.60	36.18		
					31	87.8	14.08	48.04	11.83	40.35	16.00	54.59	12.64	43.12	16.48	56.22	11.53	39.36		
	3000	1766	50	0.2	23	73.4	12.98	44.28	9.73	33.21	14.75	50.32	10.32	35.22	15.19	51.83	8.20	27.99		
					24	75.2	13.11	44.73	10.49	35.78	14.90	50.83	10.88	37.11	15.34	52.36	9.05	30.89		
					27	80.6	13.24	45.18	10.73	36.60	15.05	51.34	11.44	39.02	15.50	52.88	10.07	34.37		
					31	87.8	13.37	45.63	11.23	38.33	15.20	51.86	12.01	40.97	15.65	53.41	10.96	37.39		
	2700	1589	70	0.28	23	73.4	12.02	41.02	9.02	30.76	13.66	46.61	9.56	32.63	14.07	48.01	7.60	25.92		
					24	75.2	12.14	41.43	9.72	33.15	13.80	47.08	10.07	34.37	14.21	48.50	8.39	28.61		
					27	80.6	12.27	41.85	9.94	33.90	13.94	47.56	10.59	36.15	14.36	48.99	9.33	31.84		
					31	87.8	12.39	42.27	10.41	35.51	14.08	48.04	11.12	37.95	14.50	49.48	10.15	34.63		

Fan Speed	Air Flow Rate		ESP		Entering Air DBT		Outdoor Air Dry Bulb Temperature 77°F(25°C)													
							Indoor Air Wet Bulb Temperature °F(°C)													
			62°F(17°C)				67°F(19°C)				72°F(22°C)									
	m ³ /hr	cfm	Pa	in.wg	°C	°F	Total Capacity		Sensible Capacity		Total Capacity		Sensible Capacity		Total Capacity		Sensible Capacity			
						kW	Mbh	kW	Mbh	kW	Mbh	kW	Mbh	kW	Mbh	kW	Mbh	kW	Mbh	
Medium	3180	1872	25	0.1	23	73.4	16.81	57.37	12.61	43.02	19.11	65.19	13.37	45.63	19.68	67.14	10.63	36.26		
					24	75.2	16.98	57.95	13.59	46.36	19.30	65.85	14.09	48.07	19.88	67.83	11.73	40.02		
					27	80.6	17.16	58.54	13.90	47.41	19.50	66.52	14.82	50.55	20.08	68.51	13.05	44.53		
					31	87.8	17.33	59.12	14.56	49.66	19.69	67.18	15.56	53.08	20.28	69.20	14.20	48.44		
	3000	1766	37	0.15	23	73.4	15.86	54.12	11.90	40.59	18.02	61.50	12.62	43.05	18.56	63.34	10.03	34.21		
					24	75.2	16.02	54.67	12.82	43.74	18.21	62.13	13.29	45.35	18.75	63.99	11.07	37.75		
					27	80.6	16.18	55.22	13.11	44.73	18.39	62.75	13.98	47.69	18.94	64.64	12.31	42.01		
					31	87.8	16.35	55.78	13.73	46.85	18.58	63.38	14.67	50.07	19.13	65.28	13.39	45.70		
	2800	1648	50	0.2	23	73.4	15.07	51.41	11.30	38.56	17.12	58.42	11.99	40.90	17.64	60.18	9.52	32.50		
					24	75.2	15.22	51.94	12.18	41.55	17.30	59.02	12.63	43.08	17.82	60.79	10.51	35.87		
					27	80.6	15.38	52.46	12.45	42.49	17.47	59.62	13.28	45.31	18.00	61.40	11.70	39.91		
					31	87.8	15.53	52.99	13.04	44.51	17.65	60.21	13.94	47.57	18.18	62.02	12.72	43.41		
	2500	1471	70	0.28	23	73.4	13.96	47.62	10.47	35.72	15.86	54.12	11.10	37.88	16.34	55.74	8.82	30.10		
					24	75.2	14.10	48.11	11.28	38.49	16.02	54.67	11.70	39.91	16.50	56.31	9.74	33.22		
					27	80.6	14.24	48.60	11.54	39.36	16.18	55.22	12.30	41.97	16.67	56.88	10.84	36.97		
					31	87.8	14.39	49.08	12.08	41.23	16.35	55.78	12.91	44.06	16.84	57.45	11.79	40.21		

Fan Speed	Air Flow Rate		ESP		Entering Air DBT		Outdoor Air Dry Bulb Temperature 95°F(35°C)											
							Indoor Air Wet Bulb Temperature °F(°C)											
							62°F(17°C)				67°F(19°C)				72°F(22°C)			
							Total Capacity		Sensible Capacity		Total Capacity		Sensible Capacity		Total Capacity		Sensible Capacity	
m ³ /hr	cfm	Pa	in.wg	°C	°F	kW	Mbh	kW	Mbh	kW	Mbh	kW	Mbh	kW	Mbh	kW	Mbh	
Medium	3180	1872	25	0.1	23	73.4	15.28	52.15	11.46	39.11	17.37	59.26	12.16	41.48	17.89	61.04	9.66	32.96
					24	75.2	15.44	52.68	12.35	42.15	17.55	59.87	12.81	43.70	18.07	61.66	10.66	36.38
					27	80.6	15.60	53.21	12.63	43.10	17.72	60.47	13.47	45.96	18.25	62.29	11.87	40.49
					31	87.8	15.75	53.75	13.23	45.15	17.90	61.08	14.14	48.25	18.44	62.91	12.91	44.04
	3000	1766	37	0.15	23	73.4	14.42	49.20	10.81	36.90	16.39	55.91	11.47	39.14	16.88	57.58	9.11	31.10
					24	75.2	14.57	49.70	11.65	39.76	16.55	56.48	12.08	41.23	17.05	58.17	10.06	34.32
					27	80.6	14.71	50.20	11.92	40.66	16.72	57.05	12.71	43.36	17.22	58.76	11.19	38.19
					31	87.8	14.86	50.70	12.48	42.59	16.89	57.62	13.34	45.52	17.39	59.35	12.18	41.54
	2800	1648	50	0.2	23	73.4	13.70	46.74	10.27	35.05	15.57	53.11	10.90	37.18	16.03	54.71	8.66	29.54
					24	75.2	13.84	47.22	11.07	37.77	15.73	53.65	11.48	39.17	16.20	55.26	9.56	32.61
					27	80.6	13.98	47.69	11.32	38.63	15.88	54.20	12.07	41.19	16.36	55.82	10.63	36.28
					31	87.8	14.12	48.17	11.86	40.46	16.04	54.74	12.67	43.24	16.52	56.38	11.57	39.47
	2500	1471	70	0.28	23	73.4	12.69	43.29	9.52	32.47	14.42	49.20	10.09	34.44	14.85	50.67	8.02	27.36
					24	75.2	12.82	43.74	10.25	34.99	14.57	49.70	10.63	36.28	15.00	51.19	8.85	30.20
					27	80.6	12.95	44.18	10.49	35.78	14.71	50.20	11.18	38.15	15.16	51.71	9.85	33.61
					31	87.8	13.08	44.62	10.99	37.48	14.86	50.70	11.74	40.06	15.31	52.23	10.71	36.56

Fan Speed	Air Flow Rate		ESP		Entering Air DBT		Outdoor Air Dry Bulb Temperature 110°F(43°C)											
							Indoor Air Wet Bulb Temperature °F(°C)											
							62°F(17°C)				67°F(19°C)				72°F(22°C)			
							Total Capacity		Sensible Capacity		Total Capacity		Sensible Capacity		Total Capacity		Sensible Capacity	
m ³ /hr	cfm	Pa	in.wg	°C	°F	kW	Mbh	kW	Mbh	kW	Mbh	kW	Mbh	kW	Mbh	kW	Mbh	
Medium	3180	1872	25	0.1	23	73.4	13.76	46.94	10.32	35.20	15.63	53.34	10.94	37.34	16.10	54.94	8.69	29.67
					24	75.2	13.90	47.41	11.12	37.93	15.79	53.88	11.53	39.33	16.27	55.50	9.60	32.74
					27	80.6	14.04	47.89	11.37	38.79	15.95	54.42	12.12	41.36	16.43	56.06	10.68	36.44
					31	87.8	14.18	48.37	11.91	40.63	16.11	54.97	12.73	43.43	16.59	56.62	11.62	39.63
	3000	1766	37	0.15	23	73.4	12.98	44.28	9.73	33.21	14.75	50.32	10.32	35.22	15.19	51.83	8.20	27.99
					24	75.2	13.11	44.73	10.49	35.78	14.90	50.83	10.88	37.11	15.34	52.36	9.05	30.89
					27	80.6	13.24	45.18	10.73	36.60	15.05	51.34	11.44	39.02	15.50	52.88	10.07	34.37
					31	87.8	13.37	45.63	11.23	38.33	15.20	51.86	12.01	40.97	15.65	53.41	10.96	37.39
	2800	1648	50	0.2	23	73.4	12.33	42.06	9.25	31.55	14.01	47.80	9.81	33.46	14.43	49.24	7.79	26.59
					24	75.2	12.45	42.49	9.96	34.00	14.15	48.29	10.33	35.25	14.58	49.74	8.60	29.35
					27	80.6	12.58	42.92	10.19	34.77	14.30	48.78	10.86	37.07	14.72	50.24	9.57	32.66
					31	87.8	12.71	43.35	10.67	36.42	14.44	49.26	11.41	38.92	14.87	50.74	10.41	35.52
	2500	1471	70	0.28	23	73.4	11.42	38.97	8.57	29.22	12.98	44.28	9.08	31.00	13.37	45.61	7.22	24.63
					24	75.2	11.54	39.36	9.23	31.49	13.11	44.73	9.57	32.65	13.50	46.07	7.97	27.18
					27	80.6	11.65	39.76	9.44	32.21	13.24	45.18	10.06	34.34	13.64	46.54	8.87	30.25
					31	87.8	11.77	40.16	9.89	33.73	13.37	45.63	10.57	36.05	13.78	47.00	9.64	32.90

DC Inverter U-match Air Conditioners Technical Sales Guide

Fan Speed	Air Flow Rate		ESP		Entering Air DBT		Outdoor Air Dry Bulb Temperature 77°F(25°C)											
							Indoor Air Wet Bulb Temperature °F(°C)											
							62°F(17°C)				67°F(19°C)				72°F(22°C)			
							Total Capacity		Sensible Capacity		Total Capacity		Sensible Capacity		Total Capacity		Sensible Capacity	
m ³ /hr	cfm	Pa	in.wg	°C	°F	kW	Mbh	kW	Mbh	kW	Mbh	kW	Mbh	kW	Mbh	kW	Mbh	
Low	2780	1636	25	0.1	23	73.4	15.93	54.35	11.95	40.76	18.10	61.76	12.67	43.23	18.64	63.61	10.07	34.35
					24	75.2	16.09	54.90	12.87	43.92	18.28	62.39	13.35	45.54	18.83	64.26	11.11	37.91
					27	80.6	16.25	55.46	13.17	44.92	18.47	63.02	14.04	47.89	19.02	64.91	12.37	42.19
					31	87.8	16.42	56.01	13.79	47.05	18.65	63.65	14.74	50.28	19.21	65.56	13.45	45.89
	2600	1530	37	0.15	23	73.4	15.03	51.27	11.27	38.45	17.08	58.26	11.95	40.78	17.59	60.01	9.50	32.41
					24	75.2	15.18	51.79	12.14	41.43	17.25	58.86	12.59	42.97	17.77	60.62	10.48	35.77
					27	80.6	15.33	52.32	12.42	42.38	17.42	59.45	13.24	45.18	17.95	61.23	11.67	39.80
					31	87.8	15.49	52.84	13.01	44.39	17.60	60.05	13.90	47.44	18.13	61.85	12.69	43.29
	2400	1413	50	0.2	23	73.4	14.28	48.71	10.71	36.53	16.22	55.35	11.36	38.74	16.71	57.01	9.02	30.78
					24	75.2	14.42	49.20	11.54	39.36	16.39	55.91	11.96	40.82	16.88	57.59	9.96	33.98
					27	80.6	14.57	49.70	11.80	40.26	16.55	56.48	12.58	42.92	17.05	58.17	11.08	37.81
					31	87.8	14.71	50.20	12.36	42.17	16.72	57.04	13.21	45.06	17.22	58.75	12.05	41.13
	2100	1236	70	0.28	23	73.4	13.22	45.12	9.92	33.84	15.03	51.27	10.52	35.89	15.48	52.81	8.36	28.52
					24	75.2	13.36	45.58	10.69	36.46	15.18	51.79	11.08	37.81	15.64	53.35	9.22	31.47
					27	80.6	13.49	46.04	10.93	37.29	15.33	52.32	11.65	39.76	15.79	53.89	10.27	35.03
					31	87.8	13.63	46.50	11.45	39.06	15.49	52.84	12.23	41.74	15.95	54.42	11.17	38.10

Fan Speed	Air Flow Rate		ESP		Entering Air DBT		Outdoor Air Dry Bulb Temperature 95°F(35°C)											
							Indoor Air Wet Bulb Temperature °F(°C)											
							62°F(17°C)				67°F(19°C)				72°F(22°C)			
							Total Capacity		Sensible Capacity		Total Capacity		Sensible Capacity		Total Capacity		Sensible Capacity	
m ³ /hr	cfm	Pa	in.wg	°C	°F	kW	Mbh	kW	Mbh	kW	Mbh	kW	Mbh	kW	Mbh	kW	Mbh	
Low	2780	1636	25	0.1	23	73.4	14.48	49.41	10.86	37.05	16.45	56.14	11.52	39.30	16.95	57.83	9.15	31.23
					24	75.2	14.63	49.91	11.70	39.93	16.62	56.72	12.13	41.40	17.12	58.42	10.10	34.47
					27	80.6	14.78	50.41	11.97	40.84	16.79	57.29	12.76	43.54	17.29	59.01	11.24	38.35
					31	87.8	14.92	50.92	12.54	42.77	16.96	57.86	13.40	45.71	17.47	59.60	12.23	41.72
	2600	1530	37	0.15	23	73.4	13.66	46.61	10.25	34.96	15.52	52.97	10.87	37.08	15.99	54.55	8.63	29.46
					24	75.2	13.80	47.08	11.04	37.67	15.68	53.51	11.45	39.06	16.15	55.11	9.53	32.52
					27	80.6	13.94	47.56	11.29	38.52	15.84	54.05	12.04	41.08	16.32	55.67	10.60	36.18
					31	87.8	14.08	48.04	11.83	40.35	16.00	54.59	12.64	43.12	16.48	56.22	11.53	39.36
	2400	1413	50	0.2	23	73.4	12.98	44.28	9.73	33.21	14.75	50.32	10.32	35.22	15.19	51.83	8.20	27.99
					24	75.2	13.11	44.73	10.49	35.78	14.90	50.83	10.88	37.11	15.34	52.36	9.05	30.89
					27	80.6	13.24	45.18	10.73	36.60	15.05	51.34	11.44	39.02	15.50	52.88	10.07	34.37
					31	87.8	13.37	45.63	11.23	38.33	15.20	51.86	12.01	40.97	15.65	53.41	10.96	37.39
	2100	1236	70	0.28	23	73.4	12.02	41.02	9.02	30.76	13.66	46.61	9.56	32.63	14.07	48.01	7.60	25.92
					24	75.2	12.14	41.43	9.72	33.15	13.80	47.08	10.07	34.37	14.21	48.50	8.39	28.61
					27	80.6	12.27	41.85	9.94	33.90	13.94	47.56	10.59	36.15	14.36	48.99	9.33	31.84
					31	87.8	12.39	42.27	10.41	35.51	14.08	48.04	11.12	37.95	14.50	49.48	10.15	34.63

Fan Speed	Air Flow Rate		ESP		Entering Air DBT		Outdoor Air Dry Bulb Temperature 110°F(43°C)												
							Indoor Air Wet Bulb Temperature °F(°C)												
							62°F(17°C)				67°F(19°C)				72°F(22°C)				
m ³ /hr		cfm		Pa	in.wg	°C	°F	Total Capacity		Sensible Capacity		Total Capacity		Sensible Capacity		Total Capacity		Sensible Capacity	
						kW	Mbh	kW	Mbh	kW	Mbh	kW	Mbh	kW	Mbh	kW	Mbh	kW	Mbh
Low	2780	1636	25	0.1	23	73.4	13.03	44.47	9.77	33.35	14.81	50.53	10.37	35.37	15.25	52.04	8.24	28.10	
					24	75.2	13.17	44.92	10.53	35.94	14.96	51.04	10.92	37.26	15.41	52.58	9.09	31.02	
					27	80.6	13.30	45.37	10.77	36.75	15.11	51.56	11.48	39.19	15.56	53.11	10.12	34.52	
					31	87.8	13.43	45.83	11.28	38.49	15.26	52.08	12.06	41.14	15.72	53.64	11.00	37.55	
	2600	1530	37	0.15	23	73.4	12.29	41.95	9.22	31.46	13.97	47.67	9.78	33.37	14.39	49.10	7.77	26.51	
					24	75.2	12.42	42.38	9.94	33.90	14.11	48.16	10.30	35.15	14.54	49.60	8.58	29.26	
					27	80.6	12.55	42.80	10.16	34.67	14.26	48.64	10.83	36.97	14.68	50.10	9.54	32.57	
					31	87.8	12.67	43.23	10.64	36.32	14.40	49.13	11.37	38.81	14.83	50.60	10.38	35.42	
	2400	1413	50	0.2	23	73.4	11.68	39.85	8.76	29.89	13.27	45.29	9.29	31.70	13.67	46.64	7.38	25.19	
					24	75.2	11.80	40.26	9.44	32.21	13.41	45.75	9.79	33.40	13.81	47.12	8.15	27.80	
					27	80.6	11.92	40.66	9.65	32.94	13.54	46.21	10.29	35.12	13.95	47.60	9.07	30.94	
					31	87.8	12.04	41.07	10.11	34.50	13.68	46.67	10.81	36.87	14.09	48.07	9.86	33.65	
	2100	1236	70	0.28	23	73.4	10.82	36.91	8.11	27.69	12.29	41.95	8.61	29.36	12.66	43.21	6.84	23.33	
					24	75.2	10.93	37.29	8.74	29.83	12.42	42.38	9.07	30.93	12.79	43.65	7.55	25.75	
					27	80.6	11.04	37.67	8.94	30.51	12.55	42.80	9.53	32.53	12.92	44.09	8.40	28.66	
					31	87.8	11.15	38.04	9.37	31.96	12.67	43.23	10.01	34.15	13.05	44.53	9.14	31.17	

4.3.2 Cassette Type

GKH12K3FI:

Fan Speed	Air Flow Rate		ESP		Entering Air DBT		Outdoor Air Dry Bulb Temperature 77°F(25°C)												
							Indoor Air Wet Bulb Temperature °F(°C)												
							62°F(17°C)				67°F(19°C)				72°F(22°C)				
m ³ /hr		cfm		Pa	in.wg	°C	°F	Total Capacity		Sensible Capacity		Total Capacity		Sensible Capacity		Total Capacity		Sensible Capacity	
						kW	Mbh	kW	Mbh	kW	Mbh	kW	Mbh	kW	Mbh	kW	Mbh	kW	Mbh
High	700	412	0	0	23	73.4	3.34	11.39	2.50	8.55	3.79	12.95	2.66	9.06	3.91	13.34	2.11	7.20	
					24	75.2	3.37	11.51	2.70	9.21	3.83	13.08	2.80	9.55	3.95	13.47	2.33	7.95	
					27	80.6	3.41	11.63	2.76	9.42	3.87	13.21	2.94	10.04	3.99	13.61	2.59	8.84	
					31	87.8	3.44	11.74	2.89	9.86	3.91	13.34	3.09	10.54	4.03	13.74	2.82	9.62	
Medium	650	383	0	0	23	73.4	3.24	11.05	2.43	8.29	3.68	12.56	2.58	8.79	3.79	12.94	2.05	6.99	
					24	75.2	3.27	11.16	2.62	8.93	3.72	12.69	2.71	9.26	3.83	13.07	2.26	7.71	
					27	80.6	3.31	11.28	2.68	9.13	3.76	12.81	2.85	9.74	3.87	13.20	2.51	8.58	
					31	87.8	3.34	11.39	2.80	9.57	3.79	12.94	3.00	10.23	3.91	13.33	2.74	9.33	
Low	560	330	0	0	23	73.4	3.07	10.48	2.00	6.81	3.49	11.91	2.44	8.34	3.60	12.27	1.80	6.13	
					24	75.2	3.10	10.59	2.20	7.52	3.53	12.03	2.36	8.07	3.63	12.39	2.00	6.82	
					27	80.6	3.13	10.70	2.26	7.70	3.56	12.15	2.71	9.24	3.67	12.52	2.20	7.51	
					31	87.8	3.17	10.80	2.34	7.99	3.60	12.28	2.84	9.70	3.71	12.64	2.41	8.22	

DC Inverter U-match Air Conditioners Technical Sales Guide

Fan Speed	Air Flow Rate		ESP		Entering Air DBT		Outdoor Air Dry Bulb Temperature 95°F(35°C)											
							Indoor Air Wet Bulb Temperature °F(°C)											
	m ³ /hr cfm		Pa in.wg		°C °F		62°F(17°C)				67°F(19°C)				72°F(22°C)			
							Total Capacity		Sensible Capacity		Total Capacity		Sensible Capacity		Total Capacity		Sensible Capacity	
High	700	412	0	0	23	73.4	3.04	10.36	2.28	7.77	3.45	11.77	2.41	8.24	3.55	12.12	1.92	6.55
					24	75.2	3.07	10.46	2.45	8.37	3.48	11.89	2.54	8.68	3.59	12.25	2.12	7.23
					27	80.6	3.10	10.57	2.51	8.56	3.52	12.01	2.68	9.13	3.63	12.37	2.36	8.04
					31	87.8	3.13	10.67	2.63	8.97	3.56	12.13	2.81	9.58	3.66	12.49	2.56	8.75
Medium	650	383	0	0	23	73.4	2.94	10.05	2.21	7.54	3.35	11.42	2.34	7.99	3.45	11.76	1.86	6.35
					24	75.2	2.97	10.15	2.38	8.12	3.38	11.53	2.47	8.42	3.48	11.88	2.05	7.01
					27	80.6	3.00	10.25	2.43	8.30	3.41	11.65	2.59	8.85	3.52	12.00	2.29	7.80
					31	87.8	3.03	10.35	2.55	8.70	3.45	11.77	2.72	9.30	3.55	12.12	2.49	8.48
Low	560	330	0	0	23	73.4	2.79	9.53	1.82	6.19	3.17	10.83	2.22	7.58	3.27	11.15	1.63	5.58
					24	75.2	2.82	9.63	2.00	6.83	3.21	10.94	2.34	7.99	3.30	11.27	1.82	6.20
					27	80.6	2.85	9.72	2.05	7.00	3.24	11.05	2.46	8.40	3.34	11.38	2.00	6.83
					31	87.8	2.88	9.82	2.13	7.27	3.27	11.16	2.58	8.82	3.37	11.49	2.19	7.47

Fan Speed	Air Flow Rate		ESP		Entering Air DBT		Outdoor Air Dry Bulb Temperature 110°F(43°C)											
							Indoor Air Wet Bulb Temperature °F(°C)											
	m ³ /hr cfm		Pa in.wg		°C °F		62°F(17°C)				67°F(19°C)				72°F(22°C)			
							Total Capacity		Sensible Capacity		Total Capacity		Sensible Capacity		Total Capacity		Sensible Capacity	
High	700	412	0	0	23	73.4	2.73	9.32	2.05	6.99	3.10	10.59	2.17	7.42	3.20	10.91	1.73	5.89
					24	75.2	2.76	9.42	2.21	7.53	3.14	10.70	2.29	7.81	3.23	11.02	1.91	6.50
					27	80.6	2.79	9.51	2.26	7.70	3.17	10.81	2.41	8.22	3.26	11.13	2.12	7.24
					31	87.8	2.82	9.61	2.37	8.07	3.20	10.92	2.53	8.62	3.30	11.24	2.31	7.87
Medium	650	383	0	0	23	73.4	2.65	9.04	1.99	6.78	3.01	10.28	2.11	7.19	3.10	10.58	1.67	5.72
					24	75.2	2.68	9.13	2.14	7.31	3.04	10.38	2.22	7.58	3.13	10.69	1.85	6.31
					27	80.6	2.70	9.23	2.19	7.47	3.07	10.48	2.34	7.97	3.17	10.80	2.06	7.02
					31	87.8	2.73	9.32	2.29	7.83	3.10	10.59	2.45	8.37	3.20	10.91	2.24	7.64
Low	560	330	0	0	23	73.4	2.51	8.58	1.63	5.57	2.86	9.75	2.00	6.82	2.94	10.04	1.47	5.02
					24	75.2	2.54	8.66	1.80	6.15	2.89	9.85	2.11	7.19	2.97	10.14	1.63	5.58
					27	80.6	2.56	8.75	1.85	6.30	2.91	9.94	2.22	7.56	3.00	10.24	1.80	6.15
					31	87.8	2.59	8.84	1.92	6.54	2.94	10.04	2.33	7.93	3.03	10.35	1.97	6.72

GKH18K3FI:

Fan Speed	Air Flow Rate		ESP		Entering Air DBT		Outdoor Air Dry Bulb Temperature 77°F(25°C)											
							Indoor Air Wet Bulb Temperature °F(°C)											
	m ³ /hr cfm		Pa in.wg		°C °F		62°F(17°C)				67°F(19°C)				72°F(22°C)			
							Total Capacity		Sensible Capacity		Total Capacity		Sensible Capacity		Total Capacity		Sensible Capacity	
High	760	447	0	0	23	73.4	4.71	16.05	3.53	12.04	5.35	18.24	3.74	12.77	5.51	18.79	2.97	10.15
					24	75.2	4.75	16.22	3.80	12.97	5.40	18.43	3.94	13.45	5.56	18.98	3.28	11.20
					27	80.6	4.80	16.38	3.89	13.27	5.46	18.62	4.15	14.15	5.62	19.17	3.65	12.46
					31	87.8	4.85	16.55	4.07	13.90	5.51	18.80	4.35	14.85	5.68	19.37	3.97	13.56
Medium	720	424	0	0	23	73.4	4.56	15.57	3.42	11.68	5.19	17.70	3.63	12.39	5.34	18.23	2.88	9.84
					24	75.2	4.61	15.73	3.69	12.59	5.24	17.88	3.82	13.05	5.40	18.41	3.18	10.86
					27	80.6	4.66	15.89	3.77	12.87	5.29	18.06	4.02	13.72	5.45	18.60	3.54	12.09
					31	87.8	4.70	16.05	3.95	13.48	5.35	18.24	4.22	14.41	5.51	18.79	3.85	13.15
Low	650	383	0	0	23	73.4	4.33	14.77	2.81	9.60	4.92	16.78	3.44	11.75	5.07	17.29	2.53	8.64
					24	75.2	4.37	14.92	3.10	10.59	4.97	16.96	3.33	11.37	5.12	17.46	2.82	9.61
					27	80.6	4.42	15.07	3.18	10.85	5.02	17.13	3.81	13.02	5.17	17.64	3.10	10.58
					31	87.8	4.46	15.22	3.30	11.26	5.07	17.30	4.01	13.67	5.22	17.82	3.39	11.58

Fan Speed	Air Flow Rate		ESP		Entering Air DBT		Outdoor Air Dry Bulb Temperature 95°F(35°C)											
							Indoor Air Wet Bulb Temperature °F(°C)											
	m ³ /hr cfm		Pa in.wg		°C °F		62°F(17°C)				67°F(19°C)				72°F(22°C)			
							Total Capacity		Sensible Capacity		Total Capacity		Sensible Capacity		Total Capacity		Sensible Capacity	
High	760	447	0	0	23	73.4	4.28	14.59	3.21	10.95	4.86	16.59	3.40	11.61	5.01	17.08	2.70	9.22
					24	75.2	4.32	14.74	3.46	11.80	4.91	16.75	3.58	12.23	5.06	17.26	2.98	10.18
					27	80.6	4.36	14.89	3.54	12.06	4.96	16.92	3.77	12.86	5.11	17.43	3.32	11.33
					31	87.8	4.41	15.04	3.70	12.63	5.01	17.09	3.96	13.50	5.16	17.61	3.61	12.32
Medium	720	424	0	0	23	73.4	4.15	14.16	3.11	10.62	4.71	16.09	3.30	11.26	4.86	16.57	2.62	8.95
					24	75.2	4.19	14.30	3.35	11.44	4.76	16.25	3.48	11.86	4.91	16.74	2.89	9.88
					27	80.6	4.23	14.45	3.43	11.70	4.81	16.42	3.66	12.48	4.96	16.91	3.22	10.99
					31	87.8	4.28	14.59	3.59	12.26	4.86	16.58	3.84	13.10	5.01	17.08	3.50	11.95
Low	650	383	0	0	23	73.4	3.94	13.43	2.56	8.73	4.47	15.26	3.13	10.68	4.61	15.72	2.30	7.86
					24	75.2	3.98	13.56	2.82	9.63	4.52	15.41	3.30	11.25	4.65	15.88	2.56	8.73
					27	80.6	4.02	13.70	2.89	9.86	4.56	15.57	3.47	11.83	4.70	16.04	2.82	9.62
					31	87.8	4.06	13.84	3.00	10.24	4.61	15.73	3.64	12.42	4.75	16.20	3.09	10.53

Fan Speed	Air Flow Rate		ESP		Entering Air DBT		Outdoor Air Dry Bulb Temperature 110°F(43°C)											
							Indoor Air Wet Bulb Temperature °F(°C)											
	m ³ /hr cfm		Pa in.wg		°C °F		62°F(17°C)				67°F(19°C)				72°F(22°C)			
							Total Capacity		Sensible Capacity		Total Capacity		Sensible Capacity		Total Capacity		Sensible Capacity	
High	760	447	0	0	23	73.4	3.85	13.14	2.89	9.85	4.37	14.93	3.06	10.45	4.51	15.37	2.43	8.30
					24	75.2	3.89	13.27	3.11	10.62	4.42	15.08	3.23	11.01	4.55	15.53	2.69	9.16
					27	80.6	3.93	13.40	3.18	10.86	4.46	15.23	3.39	11.58	4.60	15.69	2.99	10.20
					31	87.8	3.97	13.54	3.33	11.37	4.51	15.38	3.56	12.15	4.64	15.84	3.25	11.09
Medium	720	424	0	0	23	73.4	3.73	12.74	2.80	9.56	4.24	14.48	2.97	10.14	4.37	14.91	2.36	8.05
					24	75.2	3.77	12.87	3.02	10.30	4.29	14.63	3.13	10.68	4.42	15.07	2.61	8.89
					27	80.6	3.81	13.00	3.09	10.53	4.33	14.77	3.29	11.23	4.46	15.22	2.90	9.89
					31	87.8	3.85	13.13	3.23	11.03	4.37	14.92	3.45	11.79	4.50	15.37	3.15	10.76
Low	650	383	0	0	23	73.4	3.54	12.08	2.30	7.85	4.02	13.73	2.82	9.61	4.15	14.14	2.07	7.07
					24	75.2	3.58	12.21	2.54	8.67	4.07	13.87	2.97	10.13	4.19	14.29	2.30	7.86
					27	80.6	3.61	12.33	2.60	8.88	4.11	14.01	3.12	10.65	4.23	14.43	2.54	8.66
					31	87.8	3.65	12.45	2.70	9.22	4.15	14.15	3.28	11.18	4.27	14.58	2.78	9.48

GKH24K3FI:

Fan Speed	Air Flow Rate		ESP		Entering Air DBT		Outdoor Air Dry Bulb Temperature 77°F(25°C)											
							Indoor Air Wet Bulb Temperature °F(°C)											
	m ³ /hr cfm		Pa in.wg		°C °F		62°F(17°C)				67°F(19°C)				72°F(22°C)			
							Total Capacity		Sensible Capacity		Total Capacity		Sensible Capacity		Total Capacity		Sensible Capacity	
High	1300	765	0	0	23	73.4	6.62	22.59	4.97	16.94	7.52	25.67	5.27	17.97	7.75	26.44	4.19	14.28
					24	75.2	6.69	22.82	5.35	18.26	7.60	25.94	5.55	18.93	7.83	26.71	4.62	15.76
					27	80.6	6.76	23.05	5.47	18.67	7.68	26.20	5.84	19.91	7.91	26.98	5.14	17.54
					31	87.8	6.82	23.28	5.73	19.56	7.75	26.46	6.13	20.90	7.99	27.25	5.59	19.08
Medium	1250	736	0	0	23	73.4	6.42	21.91	4.82	16.44	7.30	24.90	5.11	17.43	7.52	25.65	4.06	13.85
					24	75.2	6.49	22.14	5.19	17.71	7.37	25.16	5.38	18.36	7.59	25.91	4.48	15.29
					27	80.6	6.55	22.36	5.31	18.11	7.45	25.41	5.66	19.31	7.67	26.17	4.99	17.01
					31	87.8	6.62	22.59	5.56	18.97	7.52	25.67	5.94	20.28	7.75	26.44	5.42	18.50
Low	1150	677	0	0	23	73.4	6.09	20.79	3.96	13.51	6.92	23.62	4.85	16.53	7.13	24.33	3.57	12.16
					24	75.2	6.15	21.00	4.37	14.91	6.99	23.86	4.69	15.99	7.20	24.58	3.96	13.52
					27	80.6	6.22	21.21	4.48	15.27	7.06	24.10	5.37	18.32	7.28	24.82	4.37	14.89
					31	87.8	6.28	21.42	4.65	15.85	7.13	24.34	5.64	19.23	7.35	25.07	4.78	16.30

DC Inverter U-match Air Conditioners Technical Sales Guide

Fan Speed	Air Flow Rate		ESP		Entering Air DBT		Outdoor Air Dry Bulb Temperature 95°F(35°C)											
							Indoor Air Wet Bulb Temperature °F(°C)											
	m ³ /hr cfm		Pa in.wg		°C °F		62°F(17°C)				67°F(19°C)				72°F(22°C)			
							Total Capacity		Sensible Capacity		Total Capacity		Sensible Capacity		Total Capacity		Sensible Capacity	
						kW	Mbh	kW	Mbh	kW	Mbh	kW	Mbh	kW	Mbh	kW	Mbh	
High	1300	765	0	0	23	73.4	6.02	20.54	4.51	15.40	6.84	23.34	4.79	16.34	7.05	24.04	3.80	12.98
					24	75.2	6.08	20.75	4.86	16.60	6.91	23.58	5.04	17.21	7.12	24.28	4.20	14.33
					27	80.6	6.14	20.96	4.98	16.98	6.98	23.82	5.30	18.10	7.19	24.53	4.67	15.94
					31	87.8	6.20	21.17	5.21	17.78	7.05	24.05	5.57	19.00	7.26	24.78	5.08	17.34
Medium	1250	736	0	0	23	73.4	5.84	19.92	4.38	14.94	6.64	22.64	4.64	15.85	6.83	23.32	3.69	12.59
					24	75.2	5.90	20.13	4.72	16.10	6.70	22.87	4.89	16.70	6.90	23.56	4.07	13.90
					27	80.6	5.96	20.33	4.83	16.47	6.77	23.10	5.15	17.56	6.97	23.79	4.53	15.47
					31	87.8	6.02	20.53	5.05	17.25	6.84	23.33	5.40	18.43	7.04	24.03	4.93	16.82
Low	1150	677	0	0	23	73.4	5.54	18.90	3.60	12.28	6.29	21.47	4.41	15.03	6.48	22.12	3.24	11.06
					24	75.2	5.59	19.09	3.97	13.55	6.36	21.69	4.64	15.83	6.55	22.34	3.60	12.29
					27	80.6	5.65	19.28	4.07	13.88	6.42	21.91	4.88	16.65	6.61	22.57	3.97	13.54
					31	87.8	5.71	19.47	4.22	14.41	6.49	22.13	5.12	17.48	6.68	22.79	4.34	14.82

Fan Speed	Air Flow Rate		ESP		Entering Air DBT		Outdoor Air Dry Bulb Temperature 110°F(43°C)											
							Indoor Air Wet Bulb Temperature °F(°C)											
	m ³ /hr cfm		Pa in.wg		°C °F		62°F(17°C)				67°F(19°C)				72°F(22°C)			
							Total Capacity		Sensible Capacity		Total Capacity		Sensible Capacity		Total Capacity		Sensible Capacity	
						kW	Mbh	kW	Mbh	kW	Mbh	kW	Mbh	kW	Mbh	kW	Mbh	
High	1300	765	0	0	23	73.4	5.42	18.48	4.06	13.86	6.16	21.01	4.31	14.70	6.34	21.64	3.42	11.68
					24	75.2	5.47	18.67	4.38	14.94	6.22	21.22	4.54	15.49	6.41	21.86	3.78	12.90
					27	80.6	5.53	18.86	4.48	15.28	6.28	21.43	4.77	16.29	6.47	22.08	4.21	14.35
					31	87.8	5.58	19.05	4.69	16.00	6.34	21.65	5.01	17.10	6.54	22.30	4.57	15.61
Medium	1250	736	0	0	23	73.4	5.26	17.93	3.94	13.45	5.97	20.38	4.18	14.26	6.15	20.99	3.32	11.33
					24	75.2	5.31	18.11	4.25	14.49	6.03	20.58	4.40	15.03	6.21	21.20	3.67	12.51
					27	80.6	5.36	18.30	4.34	14.82	6.09	20.79	4.63	15.80	6.28	21.41	4.08	13.92
					31	87.8	5.42	18.48	4.55	15.52	6.15	21.00	4.86	16.59	6.34	21.63	4.44	15.14
Low	1150	677	0	0	23	73.4	4.98	17.01	3.24	11.05	5.66	19.33	3.96	13.53	5.83	19.90	2.92	9.95
					24	75.2	5.04	17.18	3.57	12.20	5.72	19.52	4.18	14.25	5.89	20.11	3.24	11.06
					27	80.6	5.09	17.35	3.66	12.49	5.78	19.72	4.39	14.99	5.95	20.31	3.57	12.19
					31	87.8	5.14	17.53	3.80	12.97	5.84	19.92	4.61	15.73	6.01	20.51	3.91	13.33

GKH30K3FI:

Fan Speed	Air Flow Rate		ESP		Entering Air DBT		Outdoor Air Dry Bulb Temperature 77°F(25°C)											
							Indoor Air Wet Bulb Temperature °F(°C)											
	m ³ /hr cfm		Pa in.wg		°C °F		62°F(17°C)				67°F(19°C)				72°F(22°C)			
							Total Capacity		Sensible Capacity		Total Capacity		Sensible Capacity		Total Capacity		Sensible Capacity	
						kW	Mbh	kW	Mbh	kW	Mbh	kW	Mbh	kW	Mbh	kW	Mbh	
High	1500	883	0	0	23	73.4	8.12	27.71	6.09	20.78	9.23	31.48	6.46	22.04	9.50	32.43	5.13	17.51
					24	75.2	8.20	27.99	6.56	22.39	9.32	31.81	6.80	23.22	9.60	32.76	5.66	19.33
					27	80.6	8.29	28.27	6.71	22.90	9.42	32.13	7.16	24.42	9.70	33.09	6.30	21.51
					31	87.8	8.37	28.55	7.03	23.99	9.51	32.45	7.51	25.63	9.80	33.42	6.86	23.40
Medium	1400	824	0	0	23	73.4	7.88	26.88	5.91	20.16	8.95	30.54	6.27	21.38	9.22	31.46	4.98	16.99
					24	75.2	7.96	27.15	6.37	21.72	9.04	30.85	6.60	22.52	9.31	31.78	5.49	18.75
					27	80.6	8.04	27.42	6.51	22.21	9.13	31.16	6.94	23.68	9.41	32.10	6.11	20.86
					31	87.8	8.12	27.70	6.82	23.27	9.22	31.48	7.29	24.87	9.50	32.42	6.65	22.69
Low	1300	765	0	0	23	73.4	7.47	25.49	4.86	16.57	8.49	28.97	5.94	20.28	8.74	29.84	4.37	14.92
					24	75.2	7.55	25.75	5.36	18.28	8.58	29.26	5.75	19.62	8.83	30.14	4.86	16.58
					27	80.6	7.62	26.01	5.49	18.73	8.66	29.56	6.58	22.46	8.92	30.44	5.35	18.27
					31	87.8	7.70	26.27	5.70	19.44	8.75	29.85	6.91	23.58	9.01	30.75	5.86	19.99

Fan Speed	Air Flow Rate		ESP		Entering Air DBT		Outdoor Air Dry Bulb Temperature 95°F(35°C)											
							Indoor Air Wet Bulb Temperature °F(°C)											
	m ³ /hr cfm		Pa in.wg		°C °F		62°F(17°C)				67°F(19°C)				72°F(22°C)			
							Total Capacity		Sensible Capacity		Total Capacity		Sensible Capacity		Total Capacity		Sensible Capacity	
High	1500	883	0	0	23	73.4	7.38	25.19	5.54	18.89	8.39	28.62	5.87	20.04	8.64	29.48	4.67	15.92
					24	75.2	7.46	25.44	5.97	20.36	8.47	28.91	6.19	21.11	8.73	29.78	5.15	17.57
					27	80.6	7.53	25.70	6.10	20.82	8.56	29.21	6.51	22.20	8.82	30.08	5.73	19.55
					31	87.8	7.61	25.96	6.39	21.81	8.65	29.50	6.83	23.30	8.90	30.38	6.23	21.27
Medium	1400	824	0	0	23	73.4	7.16	24.43	5.37	18.32	8.14	27.76	5.70	19.43	8.38	28.60	4.53	15.44
					24	75.2	7.23	24.68	5.79	19.75	8.22	28.05	6.00	20.47	8.47	28.89	5.00	17.04
					27	80.6	7.31	24.93	5.92	20.19	8.30	28.33	6.31	21.53	8.55	29.18	5.56	18.97
					31	87.8	7.38	25.18	6.20	21.15	8.39	28.61	6.63	22.60	8.64	29.47	6.05	20.63
Low	1300	765	0	0	23	73.4	6.79	23.17	4.41	15.06	7.72	26.33	5.40	18.43	7.95	27.12	3.97	13.56
					24	75.2	6.86	23.41	4.87	16.62	7.80	26.60	5.69	19.42	8.03	27.40	4.42	15.07
					27	80.6	6.93	23.65	4.99	17.02	7.88	26.87	5.99	20.42	8.11	27.68	4.87	16.61
					31	87.8	7.00	23.88	5.18	17.67	7.95	27.14	6.28	21.44	8.19	27.95	5.33	18.17

Fan Speed	Air Flow Rate		ESP		Entering Air DBT		Outdoor Air Dry Bulb Temperature 110°F(43°C)											
							Indoor Air Wet Bulb Temperature °F(°C)											
	m ³ /hr cfm		Pa in.wg		°C °F		62°F(17°C)				67°F(19°C)				72°F(22°C)			
							Total Capacity		Sensible Capacity		Total Capacity		Sensible Capacity		Total Capacity		Sensible Capacity	
High	1500	883	0	0	23	73.4	6.64	22.67	4.98	17.00	7.55	25.76	5.28	18.03	7.78	26.53	4.20	14.33
					24	75.2	6.71	22.90	5.37	18.32	7.63	26.02	5.57	19.00	7.86	26.80	4.63	15.81
					27	80.6	6.78	23.13	5.49	18.74	7.70	26.29	5.86	19.98	7.94	27.07	5.16	17.60
					31	87.8	6.85	23.36	5.75	19.62	7.78	26.55	6.15	20.97	8.01	27.35	5.61	19.14
Medium	1400	824	0	0	23	73.4	6.44	21.99	4.83	16.49	7.32	24.99	5.13	17.49	7.54	25.74	4.07	13.90
					24	75.2	6.51	22.21	5.21	17.77	7.40	25.24	5.40	18.43	7.62	26.00	4.50	15.34
					27	80.6	6.58	22.44	5.33	18.17	7.47	25.50	5.68	19.38	7.70	26.26	5.00	17.07
					31	87.8	6.64	22.66	5.58	19.04	7.55	25.75	5.96	20.34	7.77	26.53	5.44	18.57
Low	1300	765	0	0	23	73.4	6.11	20.86	3.97	13.56	6.95	23.70	4.86	16.59	7.15	24.41	3.58	12.21
					24	75.2	6.17	21.07	4.38	14.96	7.02	23.94	5.12	17.48	7.23	24.66	3.98	13.56
					27	80.6	6.24	21.28	4.49	15.32	7.09	24.18	5.39	18.38	7.30	24.91	4.38	14.95
					31	87.8	6.30	21.49	4.66	15.91	7.16	24.42	5.66	19.30	7.37	25.16	4.79	16.35

GKH36K3FI:

Fan Speed	Air Flow Rate		ESP		Entering Air DBT		Outdoor Air Dry Bulb Temperature 77°F(25°C)											
							Indoor Air Wet Bulb Temperature °F(°C)											
	m ³ /hr cfm		Pa in.wg		°C °F		62°F(17°C)				67°F(19°C)				72°F(22°C)			
							Total Capacity		Sensible Capacity		Total Capacity		Sensible Capacity		Total Capacity		Sensible Capacity	
High	1860	1095	0	0	23	73.4	9.62	32.82	7.21	24.62	10.93	37.30	7.65	26.11	11.26	38.42	6.08	20.74
					24	75.2	9.72	33.16	7.77	26.52	11.04	37.68	8.06	27.50	11.37	38.81	6.71	22.90
					27	80.6	9.82	33.49	7.95	27.13	11.15	38.06	8.48	28.92	11.49	39.20	7.47	25.48
					31	87.8	9.91	33.83	8.33	28.41	11.27	38.44	8.90	30.37	11.60	39.59	8.12	27.71
Medium	1750	1030	0	0	23	73.4	9.33	31.84	7.00	23.88	10.60	36.18	7.42	25.32	10.92	37.26	5.90	20.12
					24	75.2	9.43	32.16	7.54	25.73	10.71	36.55	7.82	26.68	11.03	37.64	6.51	22.21
					27	80.6	9.52	32.49	7.71	26.31	10.82	36.92	8.22	28.06	11.14	38.02	7.24	24.72
					31	87.8	9.62	32.81	8.08	27.56	10.93	37.28	8.63	29.46	11.26	38.40	7.88	26.88
Low	1550	912	0	0	23	73.4	8.85	30.20	5.75	19.63	10.06	34.31	7.04	24.02	10.36	35.34	5.18	17.67
					24	75.2	8.94	30.50	6.35	21.66	10.16	34.66	7.42	25.32	10.46	35.70	5.76	19.64
					27	80.6	9.03	30.81	6.50	22.18	10.26	35.01	7.80	26.61	10.57	36.06	6.34	21.64
					31	87.8	9.12	31.12	6.75	23.03	10.36	35.36	8.19	27.94	10.68	36.42	6.94	23.68

DC Inverter U-match Air Conditioners Technical Sales Guide

Fan Speed	Air Flow Rate		ESP		Entering Air DBT		Outdoor Air Dry Bulb Temperature 95°F(35°C)											
							Indoor Air Wet Bulb Temperature °F(°C)											
					62°F(17°C)				67°F(19°C)				72°F(22°C)					
	m ³ /hr	cfm	Pa	in.wg	°C	°F	Total Capacity		Sensible Capacity		Total Capacity		Sensible Capacity		Total Capacity		Sensible Capacity	
High	1860	1095	0	0	23	73.4	8.74	29.84	6.56	22.38	9.94	33.91	6.96	23.73	10.24	34.92	5.53	18.86
					24	75.2	8.83	30.14	7.07	24.11	10.04	34.25	7.33	25.00	10.34	35.28	6.10	20.81
					27	80.6	8.92	30.45	7.23	24.66	10.14	34.60	7.71	26.29	10.44	35.64	6.79	23.16
					31	87.8	9.01	30.75	7.57	25.83	10.24	34.94	8.09	27.61	10.55	35.99	7.38	25.19
Medium	1750	1030	0	0	23	73.4	8.48	28.94	6.36	21.71	9.64	32.89	6.75	23.02	9.93	33.88	5.36	18.29
					24	75.2	8.57	29.24	6.86	23.39	9.74	33.22	7.11	24.25	10.03	34.22	5.92	20.19
					27	80.6	8.66	29.53	7.01	23.92	9.84	33.56	7.48	25.51	10.13	34.57	6.59	22.47
					31	87.8	8.74	29.83	7.34	25.06	9.93	33.90	7.85	26.78	10.23	34.91	7.16	24.44
Low	1550	912	0	0	23	73.4	8.05	27.45	5.23	17.84	9.14	31.19	6.40	21.84	9.42	32.13	4.71	16.06
					24	75.2	8.13	27.73	5.77	19.69	9.24	31.51	6.74	23.00	9.51	32.46	5.23	17.85
					27	80.6	8.21	28.01	5.91	20.17	9.33	31.83	7.09	24.19	9.61	32.78	5.77	19.67
					31	87.8	8.29	28.29	6.14	20.93	9.42	32.15	7.44	25.40	9.70	33.11	6.31	21.52

Fan Speed	Air Flow Rate		ESP		Entering Air DBT		Outdoor Air Dry Bulb Temperature 110°F(43°C)											
							Indoor Air Wet Bulb Temperature °F(°C)											
					62°F(17°C)				67°F(19°C)				72°F(22°C)					
	m ³ /hr	cfm	Pa	in.wg	°C	°F	Total Capacity		Sensible Capacity		Total Capacity		Sensible Capacity		Total Capacity		Sensible Capacity	
High	1860	1095	0	0	23	73.4	7.87	26.85	5.90	20.14	8.94	30.52	6.26	21.36	9.21	31.43	4.97	16.97
					24	75.2	7.95	27.13	6.36	21.70	9.03	30.83	6.60	22.50	9.31	31.75	5.49	18.73
					27	80.6	8.03	27.40	6.51	22.20	9.13	31.14	6.94	23.66	9.40	32.07	6.11	20.85
					31	87.8	8.11	27.68	6.81	23.25	9.22	31.45	7.28	24.84	9.49	32.39	6.65	22.67
Medium	1750	1030	0	0	23	73.4	7.63	26.05	5.73	19.54	8.68	29.60	6.07	20.72	8.94	30.49	4.83	16.46
					24	75.2	7.71	26.31	6.17	21.05	8.76	29.90	6.40	21.83	9.03	30.80	5.33	18.17
					27	80.6	7.79	26.58	6.31	21.53	8.85	30.20	6.73	22.95	9.12	31.11	5.93	20.22
					31	87.8	7.87	26.85	6.61	22.55	8.94	30.51	7.06	24.10	9.21	31.42	6.45	21.99
Low	1550	912	0	0	23	73.4	7.24	24.71	4.71	16.06	8.23	28.07	5.76	19.65	8.47	28.92	4.24	14.46
					24	75.2	7.31	24.96	5.19	17.72	8.31	28.36	6.07	20.70	8.56	29.21	4.71	16.07
					27	80.6	7.39	25.21	5.32	18.15	8.40	28.65	6.38	21.77	8.65	29.51	5.19	17.70
					31	87.8	7.46	25.46	5.52	18.84	8.48	28.93	6.70	22.86	8.73	29.80	5.68	19.37

GKH42K3FI:

Fan Speed	Air Flow Rate		ESP		Entering Air DBT		Outdoor Air Dry Bulb Temperature 77°F(25°C)											
							Indoor Air Wet Bulb Temperature °F(°C)											
					62°F(17°C)				67°F(19°C)				72°F(22°C)					
	m ³ /hr	cfm	Pa	in.wg	°C	°F	Total Capacity		Sensible Capacity		Total Capacity		Sensible Capacity		Total Capacity		Sensible Capacity	
High	1860	1095	0	0	23	73.4	10.45	35.67	7.84	26.75	11.88	40.53	8.32	28.37	12.24	41.75	6.61	22.54
					24	75.2	10.56	36.03	8.45	28.83	12.00	40.95	8.76	29.89	12.36	42.18	7.29	24.88
					27	80.6	10.67	36.40	8.64	29.48	12.12	41.36	9.21	31.43	12.49	42.60	8.12	27.69
					31	87.8	10.77	36.76	9.05	30.88	12.24	41.77	9.67	33.00	12.61	43.03	8.83	30.12
Medium	1750	1030	0	0	23	73.4	10.14	34.60	7.61	25.95	11.52	39.32	8.07	27.52	11.87	40.50	6.41	21.87
					24	75.2	10.24	34.95	8.20	27.96	11.64	39.72	8.50	28.99	11.99	40.91	7.07	24.14
					27	80.6	10.35	35.31	8.38	28.60	11.76	40.12	8.94	30.49	12.11	41.32	7.87	26.86
					31	87.8	10.45	35.66	8.78	29.95	11.88	40.52	9.38	32.01	12.23	41.74	8.56	29.22
Low	1550	912	0	0	23	73.4	9.62	32.82	6.25	21.33	10.93	37.29	7.65	26.10	11.26	38.41	5.63	19.20
					24	75.2	9.72	33.15	6.90	23.54	11.04	37.67	7.40	25.25	11.37	38.80	6.25	21.34
					27	80.6	9.81	33.49	7.07	24.11	11.15	38.05	8.48	28.92	11.49	39.19	6.89	23.52
					31	87.8	9.91	33.82	7.33	25.03	11.26	38.43	8.90	30.36	11.60	39.58	7.54	25.73

Fan Speed	Air Flow Rate		ESP		Entering Air DBT		Outdoor Air Dry Bulb Temperature 95°F(35°C)											
							Indoor Air Wet Bulb Temperature °F(°C)											
	m ³ /hr cfm		Pa in.wg		°C °F		62°F(17°C)				67°F(19°C)				72°F(22°C)			
							Total Capacity		Sensible Capacity		Total Capacity		Sensible Capacity		Total Capacity		Sensible Capacity	
High	1860	1095	0	0	23	73.4	9.50	32.43	7.13	24.32	10.80	36.85	7.56	25.79	11.12	37.95	6.01	20.49
					24	75.2	9.60	32.76	7.68	26.21	10.91	37.22	7.96	27.17	11.24	38.34	6.63	22.62
					27	80.6	9.70	33.09	7.86	26.80	11.02	37.60	8.38	28.58	11.35	38.73	7.38	25.17
					31	87.8	9.79	33.42	8.23	28.07	11.13	37.98	8.79	30.00	11.46	39.12	8.02	27.38
Medium	1750	1030	0	0	23	73.4	9.22	31.45	6.91	23.59	10.48	35.74	7.33	25.02	10.79	36.82	5.83	19.88
					24	75.2	9.31	31.77	7.45	25.42	10.58	36.11	7.73	26.36	10.90	37.19	6.43	21.94
					27	80.6	9.41	32.10	7.62	26.00	10.69	36.47	8.12	27.72	11.01	37.57	7.16	24.42
					31	87.8	9.50	32.42	7.98	27.23	10.80	36.84	8.53	29.10	11.12	37.94	7.78	26.56
Low	1550	912	0	0	23	73.4	8.74	29.83	5.68	19.39	9.94	33.90	6.95	23.73	10.23	34.92	5.12	17.46
					24	75.2	8.83	30.14	6.27	21.40	10.04	34.25	7.33	25.00	10.34	35.27	5.69	19.40
					27	80.6	8.92	30.44	6.42	21.92	10.14	34.59	7.71	26.29	10.44	35.63	6.27	21.38
					31	87.8	9.01	30.75	6.67	22.75	10.24	34.94	8.09	27.60	10.55	35.99	6.86	23.39

Fan Speed	Air Flow Rate		ESP		Entering Air DBT		Outdoor Air Dry Bulb Temperature 110°F(43°C)											
							Indoor Air Wet Bulb Temperature °F(°C)											
	m ³ /hr cfm		Pa in.wg		°C °F		62°F(17°C)				67°F(19°C)				72°F(22°C)			
							Total Capacity		Sensible Capacity		Total Capacity		Sensible Capacity		Total Capacity		Sensible Capacity	
High	1860	1095	0	0	23	73.4	8.55	29.18	6.41	21.89	9.72	33.16	6.80	23.21	10.01	34.16	5.41	18.45
					24	75.2	8.64	29.48	6.91	23.59	9.82	33.50	7.17	24.46	10.11	34.51	5.97	20.36
					27	80.6	8.73	29.78	7.07	24.12	9.92	33.84	7.54	25.72	10.22	34.86	6.64	22.66
					31	87.8	8.82	30.08	7.40	25.26	10.02	34.18	7.91	27.00	10.32	35.20	7.22	24.64
Medium	1750	1030	0	0	23	73.4	8.30	28.31	6.22	21.23	9.43	32.17	6.60	22.52	9.71	33.13	5.24	17.89
					24	75.2	8.38	28.60	6.71	22.88	9.52	32.50	6.95	23.72	9.81	33.47	5.79	19.75
					27	80.6	8.47	28.89	6.86	23.40	9.62	32.83	7.31	24.95	9.91	33.81	6.44	21.98
					31	87.8	8.55	29.17	7.18	24.51	9.72	33.15	7.68	26.19	10.01	34.15	7.01	23.90
Low	1550	912	0	0	23	73.4	7.87	26.85	5.11	17.45	8.94	30.51	6.26	21.36	9.21	31.43	4.61	15.71
					24	75.2	7.95	27.12	5.64	19.26	9.03	30.82	6.59	22.50	9.30	31.75	5.12	17.46
					27	80.6	8.03	27.40	5.78	19.73	9.12	31.13	6.93	23.66	9.40	32.07	5.64	19.24
					31	87.8	8.11	27.67	6.00	20.48	9.22	31.44	7.28	24.84	9.49	32.39	6.17	21.05

GKH48K3FI:

Fan Speed	Air Flow Rate		ESP		Entering Air DBT		Outdoor Air Dry Bulb Temperature 77°F(25°C)											
							Indoor Air Wet Bulb Temperature °F(°C)											
	m ³ /hr cfm		Pa in.wg		°C °F		62°F(17°C)				67°F(19°C)				72°F(22°C)			
							Total Capacity		Sensible Capacity		Total Capacity		Sensible Capacity		Total Capacity		Sensible Capacity	
High	2300	1354	0	0	23	73.4	13.30	45.38	9.97	34.03	15.11	51.57	10.58	36.10	15.57	53.11	8.41	28.68
					24	75.2	13.44	45.84	10.75	36.67	15.27	52.09	11.15	38.03	15.73	53.66	9.28	31.66
					27	80.6	13.57	46.31	10.99	37.51	15.42	52.62	11.72	39.99	15.88	54.20	10.33	35.23
					31	87.8	13.71	46.77	11.51	39.29	15.58	53.15	12.31	41.99	16.04	54.74	11.23	38.32
Medium	2200	1295	0	0	23	73.4	12.90	44.02	9.68	33.01	14.66	50.02	10.26	35.01	15.10	51.52	8.15	27.82
					24	75.2	13.03	44.47	10.43	35.57	14.81	50.53	10.81	36.89	15.25	52.05	9.00	30.71
					27	80.6	13.16	44.92	10.66	36.38	14.96	51.04	11.37	38.79	15.41	52.57	10.02	34.17
					31	87.8	13.30	45.37	11.17	38.11	15.11	51.55	11.94	40.73	15.56	53.10	10.89	37.17
Low	1900	1118	0	0	23	73.4	12.24	41.75	7.95	27.14	13.90	47.44	9.73	33.21	14.32	48.87	7.16	24.43
					24	75.2	12.36	42.18	8.78	29.94	14.05	47.93	9.42	32.13	14.47	49.36	7.96	27.15
					27	80.6	12.49	42.60	8.99	30.67	14.19	48.41	10.78	36.79	14.61	49.86	8.77	29.92
					31	87.8	12.61	43.03	9.33	31.84	14.33	48.89	11.32	38.63	14.76	50.36	9.59	32.73

DC Inverter U-match Air Conditioners Technical Sales Guide

Fan Speed	Air Flow Rate		ESP		Entering Air DBT		Outdoor Air Dry Bulb Temperature 95°F(35°C)											
							Indoor Air Wet Bulb Temperature °F(°C)											
	m ³ /hr cfm		Pa in.wg		°C °F		62°F(17°C)				67°F(19°C)				72°F(22°C)			
							Total Capacity		Sensible Capacity		Total Capacity		Sensible Capacity		Total Capacity		Sensible Capacity	
High	2300	1354	0	0	23	73.4	12.09	41.25	9.07	30.94	13.74	46.88	9.62	32.82	14.15	48.29	7.64	26.07
					24	75.2	12.21	41.67	9.77	33.34	13.88	47.36	10.13	34.57	14.30	48.78	8.43	28.78
					27	80.6	12.34	42.10	9.99	34.10	14.02	47.84	10.66	36.36	14.44	49.27	9.39	32.03
					31	87.8	12.46	42.52	10.47	35.71	14.16	48.31	11.19	38.17	14.59	49.76	10.21	34.83
Medium	2200	1295	0	0	23	73.4	11.73	40.02	8.80	30.01	13.33	45.47	9.33	31.83	13.73	46.84	7.41	25.29
					24	75.2	11.85	40.42	9.48	32.34	13.46	45.94	9.83	33.53	13.87	47.32	8.18	27.92
					27	80.6	11.97	40.83	9.69	33.07	13.60	46.40	10.34	35.26	14.01	47.79	9.10	31.07
					31	87.8	12.09	41.24	10.15	34.64	13.74	46.87	10.85	37.02	14.15	48.27	9.90	33.79
Low	1900	1118	0	0	23	73.4	11.12	37.95	7.23	24.67	12.64	43.13	8.85	30.19	13.02	44.42	6.51	22.21
					24	75.2	11.24	38.34	7.98	27.22	12.77	43.57	9.32	31.81	13.15	44.88	7.23	24.68
					27	80.6	11.35	38.73	8.17	27.88	12.90	44.01	9.80	33.45	13.29	45.33	7.97	27.20
					31	87.8	11.46	39.12	8.48	28.95	13.03	44.45	10.29	35.12	13.42	45.78	8.72	29.76

Fan Speed	Air Flow Rate		ESP		Entering Air DBT		Outdoor Air Dry Bulb Temperature 110°F(43°C)											
							Indoor Air Wet Bulb Temperature °F(°C)											
	m ³ /hr cfm		Pa in.wg		°C °F		62°F(17°C)				67°F(19°C)				72°F(22°C)			
							Total Capacity		Sensible Capacity		Total Capacity		Sensible Capacity		Total Capacity		Sensible Capacity	
High	2300	1354	0	0	23	73.4	10.88	37.13	8.16	27.85	12.37	42.19	8.66	29.53	12.74	43.46	6.88	23.47
					24	75.2	10.99	37.51	8.79	30.01	12.49	42.62	9.12	31.11	12.87	43.90	7.59	25.90
					27	80.6	11.10	37.89	8.99	30.69	12.62	43.05	9.59	32.72	13.00	44.34	8.45	28.82
					31	87.8	11.21	38.27	9.42	32.14	12.74	43.48	10.07	34.35	13.13	44.79	9.19	31.35
Medium	2200	1295	0	0	23	73.4	10.56	36.01	7.92	27.01	11.99	40.93	8.40	28.65	12.35	42.15	6.67	22.76
					24	75.2	10.66	36.38	8.53	29.11	12.12	41.34	8.85	30.18	12.48	42.58	7.36	25.12
					27	80.6	10.77	36.75	8.72	29.77	12.24	41.76	9.30	31.74	12.61	43.01	8.19	27.96
					31	87.8	10.88	37.12	9.14	31.18	12.36	42.18	9.77	33.32	12.73	43.44	8.91	30.41
Low	1900	1118	0	0	23	73.4	10.01	34.16	6.51	22.20	11.38	38.82	7.96	27.17	11.72	39.98	5.86	19.99
					24	75.2	10.11	34.51	7.18	24.50	11.49	39.21	8.39	28.62	11.84	40.39	6.51	22.21
					27	80.6	10.22	34.86	7.36	25.10	11.61	39.61	8.82	30.10	11.96	40.80	7.17	24.48
					31	87.8	10.32	35.20	7.64	26.05	11.72	40.00	9.26	31.60	12.08	41.20	7.85	26.78

GKH60K3FI:

Fan Speed	Air Flow Rate		ESP		Entering Air DBT		Outdoor Air Dry Bulb Temperature 77°F(25°C)											
							Indoor Air Wet Bulb Temperature °F(°C)											
	m ³ /hr cfm		Pa in.wg		°C °F		62°F(17°C)				67°F(19°C)				72°F(22°C)			
							Total Capacity		Sensible Capacity		Total Capacity		Sensible Capacity		Total Capacity		Sensible Capacity	
High	2400	1413	0	0	23	73.4	15.98	54.51	11.98	40.88	18.15	61.94	12.71	43.36	18.70	63.80	10.10	34.45
					24	75.2	16.14	55.06	12.91	44.05	18.34	62.57	13.39	45.68	18.89	64.45	11.14	38.02
					27	80.6	16.30	55.62	13.20	45.05	18.52	63.20	14.08	48.03	19.08	65.10	12.40	42.32
					31	87.8	16.46	56.18	13.83	47.19	18.71	63.84	14.78	50.43	19.27	65.75	13.49	46.03
Medium	2300	1354	0	0	23	73.4	15.50	52.87	11.62	39.65	17.61	60.08	12.33	42.06	18.14	61.88	9.79	33.42
					24	75.2	15.65	53.41	12.52	42.73	17.79	60.69	12.99	44.31	18.32	62.52	10.81	36.88
					27	80.6	15.81	53.95	12.81	43.70	17.97	61.31	13.66	46.59	18.51	63.15	12.03	41.05
					31	87.8	15.97	54.49	13.41	45.77	18.15	61.92	14.34	48.92	18.69	63.78	13.08	44.64
Low	1900	1118	0	0	23	73.4	14.70	50.15	9.55	32.60	16.70	56.98	11.69	39.89	17.20	58.69	8.60	29.35
					24	75.2	14.85	50.66	10.54	35.97	16.87	57.57	11.31	38.59	17.38	59.29	9.56	32.61
					27	80.6	15.00	51.17	10.80	36.84	17.04	58.15	12.95	44.19	17.55	59.89	10.53	35.94
					31	87.8	15.15	51.68	11.21	38.24	17.21	58.73	13.60	46.40	17.73	60.49	11.52	39.32

DC Inverter U-match Air Conditioners Technical Sales Guide

Fan Speed	Air Flow Rate		ESP		Entering Air DBT		Outdoor Air Dry Bulb Temperature 95°F(35°C)											
							Indoor Air Wet Bulb Temperature °F(°C)											
	m ³ /hr cfm		Pa in.wg		°C °F		62°F(17°C)				67°F(19°C)				72°F(22°C)			
							Total Capacity		Sensible Capacity		Total Capacity		Sensible Capacity		Total Capacity		Sensible Capacity	
						kW	Mbh	kW	Mbh	kW	Mbh	kW	Mbh	kW	Mbh	kW	Mbh	
High	600	353	0	0	23	73.4	2.35	8.00	1.76	6.00	2.67	9.10	1.87	6.37	2.75	9.37	1.48	5.06
					24	75.2	2.37	8.09	1.90	6.47	2.69	9.19	1.97	6.71	2.77	9.46	1.64	5.58
					27	80.6	2.39	8.17	1.94	6.62	2.72	9.28	2.07	7.05	2.80	9.56	1.82	6.21
					31	87.8	2.42	8.25	2.03	6.93	2.75	9.37	2.17	7.41	2.83	9.65	1.98	6.76
Medium	520	306	0	0	23	73.4	2.28	7.76	1.71	5.82	2.59	8.82	1.81	6.18	2.66	9.09	1.44	4.91
					24	75.2	2.30	7.84	1.84	6.27	2.61	8.91	1.91	6.51	2.69	9.18	1.59	5.42
					27	80.6	2.32	7.92	1.88	6.42	2.64	9.00	2.01	6.84	2.72	9.27	1.77	6.03
					31	87.8	2.35	8.00	1.97	6.72	2.66	9.09	2.11	7.18	2.74	9.37	1.92	6.56
Low	480	283	0	0	23	73.4	2.16	7.36	1.40	4.79	2.45	8.37	1.72	5.86	2.53	8.62	1.26	4.31
					24	75.2	2.18	7.44	1.55	5.28	2.48	8.45	1.81	6.17	2.55	8.71	1.40	4.79
					27	80.6	2.20	7.51	1.59	5.41	2.50	8.54	1.90	6.49	2.58	8.79	1.55	5.28
					31	87.8	2.22	7.59	1.65	5.62	2.53	8.62	2.00	6.81	2.60	8.88	1.69	5.77

Fan Speed	Air Flow Rate		ESP		Entering Air DBT		Outdoor Air Dry Bulb Temperature 110°F(43°C)											
							Indoor Air Wet Bulb Temperature °F(°C)											
	m ³ /hr cfm		Pa in.wg		°C °F		62°F(17°C)				67°F(19°C)				72°F(22°C)			
							Total Capacity		Sensible Capacity		Total Capacity		Sensible Capacity		Total Capacity		Sensible Capacity	
						kW	Mbh	kW	Mbh	kW	Mbh	kW	Mbh	kW	Mbh	kW	Mbh	
High	600	353	0	0	23	73.4	2.11	7.20	1.58	5.40	2.40	8.19	1.68	5.73	2.47	8.43	1.33	4.55
					24	75.2	2.13	7.28	1.71	5.82	2.42	8.27	1.77	6.04	2.50	8.52	1.47	5.03
					27	80.6	2.15	7.35	1.74	5.95	2.45	8.35	1.86	6.35	2.52	8.60	1.64	5.59
					31	87.8	2.18	7.42	1.83	6.24	2.47	8.44	1.95	6.66	2.55	8.69	1.78	6.08
Medium	520	306	0	0	23	73.4	2.05	6.99	1.54	5.24	2.33	7.94	1.63	5.56	2.40	8.18	1.29	4.42
					24	75.2	2.07	7.06	1.65	5.65	2.35	8.02	1.72	5.86	2.42	8.26	1.43	4.87
					27	80.6	2.09	7.13	1.69	5.78	2.37	8.10	1.80	6.16	2.45	8.35	1.59	5.42
					31	87.8	2.11	7.20	1.77	6.05	2.40	8.18	1.89	6.46	2.47	8.43	1.73	5.90
Low	480	283	0	0	23	73.4	1.94	6.63	1.26	4.31	2.21	7.53	1.54	5.27	2.27	7.76	1.14	3.88
					24	75.2	1.96	6.69	1.39	4.75	2.23	7.61	1.63	5.55	2.30	7.84	1.26	4.31
					27	80.6	1.98	6.76	1.43	4.87	2.25	7.68	1.71	5.84	2.32	7.91	1.39	4.75
					31	87.8	2.00	6.83	1.48	5.05	2.27	7.76	1.80	6.13	2.34	7.99	1.52	5.20

GTH12K3FI:

Fan Speed	Air Flow Rate		ESP		Entering Air DBT		Outdoor Air Dry Bulb Temperature 77°F(25°C)											
							Indoor Air Wet Bulb Temperature °F(°C)											
	m ³ /hr cfm		Pa in.wg		°C °F		62°F(17°C)				67°F(19°C)				72°F(22°C)			
							Total Capacity		Sensible Capacity		Total Capacity		Sensible Capacity		Total Capacity		Sensible Capacity	
						kW	Mbh	kW	Mbh	kW	Mbh	kW	Mbh	kW	Mbh	kW	Mbh	
High	700	412	0	0	23	73.4	3.36	11.46	2.52	8.59	3.82	13.02	2.67	9.11	3.93	13.41	2.12	7.24
					24	75.2	3.39	11.58	2.71	9.26	3.86	13.15	2.81	9.60	3.97	13.55	2.34	7.99
					27	80.6	3.43	11.69	2.78	9.47	3.89	13.29	2.96	10.10	4.01	13.68	2.61	8.90
					31	87.8	3.46	11.81	2.91	9.92	3.93	13.42	3.11	10.60	4.05	13.82	2.84	9.68
Medium	650	383	0	0	23	73.4	3.26	11.11	2.44	8.34	3.70	12.63	2.59	8.84	3.81	13.01	2.06	7.02
					24	75.2	3.29	11.23	2.63	8.98	3.74	12.76	2.73	9.31	3.85	13.14	2.27	7.75
					27	80.6	3.32	11.34	2.69	9.19	3.78	12.89	2.87	9.79	3.89	13.27	2.53	8.63
					31	87.8	3.36	11.45	2.82	9.62	3.81	13.02	3.01	10.28	3.93	13.41	2.75	9.38
Low	580	341	0	0	23	73.4	3.09	10.54	2.01	6.85	3.51	11.98	2.46	8.39	3.62	12.34	1.81	6.17
					24	75.2	3.12	10.65	2.22	7.56	3.55	12.10	2.38	8.11	3.65	12.46	2.01	6.86
					27	80.6	3.15	10.76	2.27	7.74	3.58	12.22	2.72	9.29	3.69	12.59	2.21	7.55
					31	87.8	3.18	10.86	2.36	8.04	3.62	12.35	2.86	9.75	3.73	12.72	2.42	8.27

Fan Speed	Air Flow Rate		ESP		Entering Air DBT		Outdoor Air Dry Bulb Temperature 95°F(35°C)											
							Indoor Air Wet Bulb Temperature °F(°C)											
	m ³ /hr cfm		Pa in.wg		°C °F		62°F(17°C)				67°F(19°C)				72°F(22°C)			
							Total Capacity		Sensible Capacity		Total Capacity		Sensible Capacity		Total Capacity		Sensible Capacity	
High	700	412	0	0	23	73.4	3.05	10.42	2.29	7.81	3.47	11.84	2.43	8.29	3.57	12.19	1.93	6.58
					24	75.2	3.08	10.52	2.47	8.42	3.50	11.96	2.56	8.73	3.61	12.32	2.13	7.27
					27	80.6	3.12	10.63	2.52	8.61	3.54	12.08	2.69	9.18	3.65	12.44	2.37	8.09
					31	87.8	3.15	10.74	2.64	9.02	3.58	12.20	2.82	9.64	3.68	12.57	2.58	8.80
Medium	650	383	0	0	23	73.4	2.96	10.10	2.22	7.58	3.37	11.48	2.36	8.04	3.47	11.83	1.87	6.39
					24	75.2	2.99	10.21	2.39	8.17	3.40	11.60	2.48	8.47	3.50	11.95	2.07	7.05
					27	80.6	3.02	10.31	2.45	8.35	3.43	11.72	2.61	8.90	3.54	12.07	2.30	7.84
					31	87.8	3.05	10.41	2.56	8.75	3.47	11.83	2.74	9.35	3.57	12.19	2.50	8.53
Low	580	341	0	0	23	73.4	2.81	9.58	1.83	6.23	3.19	10.89	2.23	7.62	3.29	11.22	1.64	5.61
					24	75.2	2.84	9.68	2.01	6.87	3.22	11.00	2.35	8.03	3.32	11.33	1.83	6.23
					27	80.6	2.87	9.78	2.06	7.04	3.26	11.11	2.48	8.45	3.35	11.45	2.01	6.87
					31	87.8	2.89	9.88	2.14	7.31	3.29	11.22	2.60	8.87	3.39	11.56	2.20	7.51

Fan Speed	Air Flow Rate		ESP		Entering Air DBT		Outdoor Air Dry Bulb Temperature 110°F(43°C)											
							Indoor Air Wet Bulb Temperature °F(°C)											
	m ³ /hr cfm		Pa in.wg		°C °F		62°F(17°C)				67°F(19°C)				72°F(22°C)			
							Total Capacity		Sensible Capacity		Total Capacity		Sensible Capacity		Total Capacity		Sensible Capacity	
High	700	412	0	0	23	73.4	2.75	9.37	2.06	7.03	3.12	10.65	2.19	7.46	3.22	10.97	1.74	5.93
					24	75.2	2.78	9.47	2.22	7.58	3.15	10.76	2.30	7.86	3.25	11.08	1.92	6.54
					27	80.6	2.80	9.57	2.27	7.75	3.19	10.87	2.42	8.26	3.28	11.20	2.13	7.28
					31	87.8	2.83	9.66	2.38	8.12	3.22	10.98	2.54	8.67	3.31	11.31	2.32	7.92
Medium	650	383	0	0	23	73.4	2.67	9.09	2.00	6.82	3.03	10.33	2.12	7.23	3.12	10.64	1.68	5.75
					24	75.2	2.69	9.19	2.15	7.35	3.06	10.44	2.23	7.62	3.15	10.75	1.86	6.34
					27	80.6	2.72	9.28	2.20	7.52	3.09	10.54	2.35	8.01	3.18	10.86	2.07	7.06
					31	87.8	2.75	9.37	2.31	7.87	3.12	10.65	2.47	8.41	3.21	10.97	2.25	7.68
Low	580	341	0	0	23	73.4	2.53	8.62	1.64	5.61	2.87	9.80	2.01	6.86	2.96	10.09	1.48	5.05
					24	75.2	2.55	8.71	1.81	6.19	2.90	9.90	2.12	7.23	2.99	10.20	1.64	5.61
					27	80.6	2.58	8.80	1.86	6.34	2.93	10.00	2.23	7.60	3.02	10.30	1.81	6.18
					31	87.8	2.61	8.89	1.93	6.58	2.96	10.10	2.34	7.98	3.05	10.40	1.98	6.76

GTH18K3FI:

Fan Speed	Air Flow Rate		ESP		Entering Air DBT		Outdoor Air Dry Bulb Temperature 77°F(25°C)											
							Indoor Air Wet Bulb Temperature °F(°C)											
	m ³ /hr cfm		Pa in.wg		°C °F		62°F(17°C)				67°F(19°C)				72°F(22°C)			
							Total Capacity		Sensible Capacity		Total Capacity		Sensible Capacity		Total Capacity		Sensible Capacity	
High	1000	589	0	0	23	73.4	4.71	16.05	3.53	12.04	5.35	18.24	3.74	12.77	5.51	18.79	2.97	10.15
					24	75.2	4.75	16.22	3.80	12.97	5.40	18.43	3.94	13.45	5.56	18.98	3.28	11.20
					27	80.6	4.80	16.38	3.89	13.27	5.46	18.62	4.15	14.15	5.62	19.17	3.65	12.46
					31	87.8	4.85	16.55	4.07	13.90	5.51	18.80	4.35	14.85	5.68	19.37	3.97	13.56
Medium	940	553	0	0	23	73.4	4.56	15.57	3.42	11.68	5.19	17.70	3.63	12.39	5.34	18.23	2.88	9.84
					24	75.2	4.61	15.73	3.69	12.59	5.24	17.88	3.82	13.05	5.40	18.41	3.18	10.86
					27	80.6	4.66	15.89	3.77	12.87	5.29	18.06	4.02	13.72	5.45	18.60	3.54	12.09
					31	87.8	4.70	16.05	3.95	13.48	5.35	18.24	4.22	14.41	5.51	18.79	3.85	13.15
Low	820	483	0	0	23	73.4	4.33	14.77	2.81	9.60	4.92	16.78	3.44	11.75	5.07	17.29	2.53	8.64
					24	75.2	4.37	14.92	3.10	10.59	4.97	16.96	3.33	11.37	5.12	17.46	2.82	9.61
					27	80.6	4.42	15.07	3.18	10.85	5.02	17.13	3.81	13.02	5.17	17.64	3.10	10.58
					31	87.8	4.46	15.22	3.30	11.26	5.07	17.30	4.01	13.67	5.22	17.82	3.39	11.58

DC Inverter U-match Air Conditioners Technical Sales Guide

Fan Speed	Air Flow Rate		ESP		Entering Air DBT		Outdoor Air Dry Bulb Temperature 95°F(35°C)											
							Indoor Air Wet Bulb Temperature °F(°C)											
	m ³ /hr cfm		Pa in.wg		°C °F		62°F(17°C)				67°F(19°C)				72°F(22°C)			
							Total Capacity		Sensible Capacity		Total Capacity		Sensible Capacity		Total Capacity		Sensible Capacity	
High	1000	589	0	0	23	73.4	4.28	14.59	3.21	10.95	4.86	16.59	3.40	11.61	5.01	17.08	2.70	9.22
					24	75.2	4.32	14.74	3.46	11.80	4.91	16.75	3.58	12.23	5.06	17.26	2.98	10.18
					27	80.6	4.36	14.89	3.54	12.06	4.96	16.92	3.77	12.86	5.11	17.43	3.32	11.33
					31	87.8	4.41	15.04	3.70	12.63	5.01	17.09	3.96	13.50	5.16	17.61	3.61	12.32
Medium	940	553	0	0	23	73.4	4.15	14.16	3.11	10.62	4.71	16.09	3.30	11.26	4.86	16.57	2.62	8.95
					24	75.2	4.19	14.30	3.35	11.44	4.76	16.25	3.48	11.86	4.91	16.74	2.89	9.88
					27	80.6	4.23	14.45	3.43	11.70	4.81	16.42	3.66	12.48	4.96	16.91	3.22	10.99
					31	87.8	4.28	14.59	3.59	12.26	4.86	16.58	3.84	13.10	5.01	17.08	3.50	11.95
Low	820	483	0	0	23	73.4	3.94	13.43	2.56	8.73	4.47	15.26	3.13	10.68	4.61	15.72	2.30	7.86
					24	75.2	3.98	13.56	2.82	9.63	4.52	15.41	3.30	11.25	4.65	15.88	2.56	8.73
					27	80.6	4.02	13.70	2.89	9.86	4.56	15.57	3.47	11.83	4.70	16.04	2.82	9.62
					31	87.8	4.06	13.84	3.00	10.24	4.61	15.73	3.64	12.42	4.75	16.20	3.09	10.53

Fan Speed	Air Flow Rate		ESP		Entering Air DBT		Outdoor Air Dry Bulb Temperature 110°F(43°C)											
							Indoor Air Wet Bulb Temperature °F(°C)											
	m ³ /hr cfm		Pa in.wg		°C °F		62°F(17°C)				67°F(19°C)				72°F(22°C)			
							Total Capacity		Sensible Capacity		Total Capacity		Sensible Capacity		Total Capacity		Sensible Capacity	
High	1000	589	0	0	23	73.4	3.85	13.14	2.89	9.85	4.37	14.93	3.06	10.45	4.51	15.37	2.43	8.30
					24	75.2	3.89	13.27	3.11	10.62	4.42	15.08	3.23	11.01	4.55	15.53	2.69	9.16
					27	80.6	3.93	13.40	3.18	10.86	4.46	15.23	3.39	11.58	4.60	15.69	2.99	10.20
					31	87.8	3.97	13.54	3.33	11.37	4.51	15.38	3.56	12.15	4.64	15.84	3.25	11.09
Medium	940	553	0	0	23	73.4	3.73	12.74	2.80	9.56	4.24	14.48	2.97	10.14	4.37	14.91	2.36	8.05
					24	75.2	3.77	12.87	3.02	10.30	4.29	14.63	3.13	10.68	4.42	15.07	2.61	8.89
					27	80.6	3.81	13.00	3.09	10.53	4.33	14.77	3.29	11.23	4.46	15.22	2.90	9.89
					31	87.8	3.85	13.13	3.23	11.03	4.37	14.92	3.45	11.79	4.50	15.37	3.15	10.76
Low	820	483	0	0	23	73.4	3.54	12.08	2.30	7.85	4.02	13.73	2.82	9.61	4.15	14.14	2.07	7.07
					24	75.2	3.58	12.21	2.54	8.67	4.07	13.87	2.97	10.13	4.19	14.29	2.30	7.86
					27	80.6	3.61	12.33	2.60	8.88	4.11	14.01	3.12	10.65	4.23	14.43	2.54	8.66
					31	87.8	3.65	12.45	2.70	9.22	4.15	14.15	3.28	11.18	4.27	14.58	2.78	9.48

GTH24K3FI:

Fan Speed	Air Flow Rate		ESP		Entering Air DBT		Outdoor Air Dry Bulb Temperature 77°F(25°C)											
							Indoor Air Wet Bulb Temperature °F(°C)											
	m ³ /hr cfm		Pa in.wg		°C °F		62°F(17°C)				67°F(19°C)				72°F(22°C)			
							Total Capacity		Sensible Capacity		Total Capacity		Sensible Capacity		Total Capacity		Sensible Capacity	
High	1200	706	0	0	23	73.4	6.58	22.46	4.94	16.85	7.48	25.53	5.24	17.87	7.71	26.29	4.16	14.20
					24	75.2	6.65	22.69	5.32	18.15	7.56	25.79	5.52	18.82	7.78	26.56	4.59	15.67
					27	80.6	6.72	22.92	5.44	18.57	7.63	26.05	5.80	19.80	7.86	26.83	5.11	17.44
					31	87.8	6.79	23.15	5.70	19.45	7.71	26.31	6.09	20.78	7.94	27.10	5.56	18.97
Medium	1150	677	0	0	23	73.4	6.39	21.79	4.79	16.34	7.26	24.76	5.08	17.33	7.47	25.50	4.04	13.77
					24	75.2	6.45	22.01	5.16	17.61	7.33	25.01	5.35	18.26	7.55	25.76	4.46	15.20
					27	80.6	6.52	22.23	5.28	18.01	7.40	25.27	5.63	19.20	7.63	26.02	4.96	16.92
					31	87.8	6.58	22.46	5.53	18.86	7.48	25.52	5.91	20.16	7.70	26.28	5.39	18.40
Low	1050	618	0	0	23	73.4	6.06	20.67	3.94	13.43	6.88	23.48	4.82	16.44	7.09	24.19	3.54	12.09
					24	75.2	6.12	20.88	4.34	14.82	6.95	23.72	4.66	15.90	7.16	24.44	3.94	13.44
					27	80.6	6.18	21.09	4.45	15.18	7.02	23.96	5.34	18.21	7.23	24.68	4.34	14.81
					31	87.8	6.24	21.30	4.62	15.76	7.09	24.20	5.60	19.12	7.31	24.93	4.75	16.20

Fan Speed	Air Flow Rate		ESP		Entering Air DBT		Outdoor Air Dry Bulb Temperature 95°F(35°C)											
							Indoor Air Wet Bulb Temperature °F(°C)											
	m ³ /hr cfm		Pa in.wg		°C °F		62°F(17°C)				67°F(19°C)				72°F(22°C)			
							Total Capacity		Sensible Capacity		Total Capacity		Sensible Capacity		Total Capacity		Sensible Capacity	
High	1200	706	0	0	23	73.4	5.99	20.42	4.49	15.32	6.80	23.21	4.76	16.24	7.01	23.90	3.78	12.91
					24	75.2	6.05	20.63	4.84	16.50	6.87	23.44	5.02	17.11	7.08	24.15	4.18	14.25
					27	80.6	6.11	20.84	4.95	16.88	6.94	23.68	5.27	18.00	7.15	24.39	4.65	15.85
					31	87.8	6.17	21.05	5.18	17.68	7.01	23.92	5.54	18.89	7.22	24.63	5.05	17.24
Medium	1150	677	0	0	23	73.4	5.81	19.81	4.35	14.86	6.60	22.51	4.62	15.76	6.80	23.18	3.67	12.52
					24	75.2	5.86	20.01	4.69	16.01	6.66	22.74	4.87	16.60	6.86	23.42	4.05	13.82
					27	80.6	5.92	20.21	4.80	16.37	6.73	22.97	5.12	17.46	6.93	23.66	4.51	15.38
					31	87.8	5.98	20.41	5.03	17.15	6.80	23.20	5.37	18.33	7.00	23.89	4.90	16.73
Low	1050	618	0	0	23	73.4	5.51	18.79	3.58	12.21	6.26	21.35	4.38	14.94	6.44	21.99	3.22	10.99
					24	75.2	5.56	18.98	3.95	13.48	6.32	21.57	4.61	15.74	6.51	22.21	3.58	12.22
					27	80.6	5.62	19.17	4.05	13.80	6.38	21.78	4.85	16.56	6.58	22.44	3.95	13.46
					31	87.8	5.67	19.36	4.20	14.33	6.45	22.00	5.09	17.38	6.64	22.66	4.32	14.73

Fan Speed	Air Flow Rate		ESP		Entering Air DBT		Outdoor Air Dry Bulb Temperature 110°F(43°C)											
							Indoor Air Wet Bulb Temperature °F(°C)											
	m ³ /hr cfm		Pa in.wg		°C °F		62°F(17°C)				67°F(19°C)				72°F(22°C)			
							Total Capacity		Sensible Capacity		Total Capacity		Sensible Capacity		Total Capacity		Sensible Capacity	
High	1200	706	0	0	23	73.4	5.39	18.38	4.04	13.78	6.12	20.89	4.28	14.62	6.30	21.51	3.40	11.62
					24	75.2	5.44	18.57	4.35	14.85	6.18	21.10	4.51	15.40	6.37	21.73	3.76	12.82
					27	80.6	5.50	18.75	4.45	15.19	6.25	21.31	4.75	16.20	6.43	21.95	4.18	14.27
					31	87.8	5.55	18.94	4.66	15.91	6.31	21.52	4.98	17.00	6.50	22.17	4.55	15.52
Medium	1150	677	0	0	23	73.4	5.22	17.83	3.92	13.37	5.94	20.26	4.16	14.18	6.12	20.87	3.30	11.27
					24	75.2	5.28	18.01	4.22	14.41	6.00	20.47	4.38	14.94	6.18	21.08	3.65	12.44
					27	80.6	5.33	18.19	4.32	14.74	6.06	20.67	4.60	15.71	6.24	21.29	4.06	13.84
					31	87.8	5.38	18.37	4.52	15.43	6.12	20.88	4.83	16.49	6.30	21.51	4.41	15.05
Low	1050	618	0	0	23	73.4	4.96	16.91	3.22	10.99	5.63	19.21	3.94	13.45	5.80	19.79	2.90	9.90
					24	75.2	5.01	17.08	3.55	12.13	5.69	19.41	4.15	14.17	5.86	19.99	3.22	11.00
					27	80.6	5.06	17.25	3.64	12.42	5.75	19.61	4.37	14.90	5.92	20.19	3.55	12.12
					31	87.8	5.11	17.43	3.78	12.90	5.80	19.80	4.58	15.64	5.98	20.40	3.89	13.26

GTH30K3FI:

Fan Speed	Air Flow Rate		ESP		Entering Air DBT		Outdoor Air Dry Bulb Temperature 77°F(25°C)											
							Indoor Air Wet Bulb Temperature °F(°C)											
	m ³ /hr cfm		Pa in.wg		°C °F		62°F(17°C)				67°F(19°C)				72°F(22°C)			
							Total Capacity		Sensible Capacity		Total Capacity		Sensible Capacity		Total Capacity		Sensible Capacity	
High	1500	883	0	0	23	73.4	8.03	27.38	6.02	20.54	9.12	31.12	6.38	21.78	9.39	32.05	5.07	17.31
					24	75.2	8.11	27.66	6.49	22.13	9.21	31.43	6.73	22.95	9.49	32.38	5.60	19.10
					27	80.6	8.19	27.94	6.63	22.63	9.31	31.75	7.07	24.13	9.59	32.70	6.23	21.26
					31	87.8	8.27	28.22	6.95	23.71	9.40	32.07	7.43	25.33	9.68	33.03	6.78	23.12
Medium	1400	824	0	0	23	73.4	7.78	26.56	5.84	19.92	8.85	30.18	6.19	21.13	9.11	31.09	4.92	16.79
					24	75.2	7.86	26.83	6.29	21.47	8.94	30.49	6.52	22.26	9.20	31.41	5.43	18.53
					27	80.6	7.94	27.10	6.43	21.95	9.03	30.80	6.86	23.41	9.30	31.72	6.04	20.62
					31	87.8	8.02	27.37	6.74	22.99	9.12	31.11	7.20	24.57	9.39	32.04	6.57	22.43
Low	1350	795	0	0	23	73.4	7.38	25.19	4.80	16.38	8.39	28.63	5.87	20.04	8.64	29.49	4.32	14.74
					24	75.2	7.46	25.45	5.30	18.07	8.48	28.92	6.19	21.13	8.73	29.79	4.80	16.38
					27	80.6	7.53	25.71	5.42	18.51	8.56	29.21	6.51	22.20	8.82	30.09	5.29	18.05
					31	87.8	7.61	25.96	5.63	19.21	8.65	29.50	6.83	23.31	8.91	30.39	5.79	19.75

DC Inverter U-match Air Conditioners Technical Sales Guide

Fan Speed	Air Flow Rate		ESP		Entering Air DBT		Outdoor Air Dry Bulb Temperature 95°F(35°C)											
							Indoor Air Wet Bulb Temperature °F(°C)											
					62°F(17°C)				67°F(19°C)				72°F(22°C)					
	m³/hr	cfm	Pa	in.wg	°C	°F	Total Capacity		Sensible Capacity		Total Capacity		Sensible Capacity		Total Capacity		Sensible Capacity	
High	1500	883	0	0	23	73.4	7.30	24.89	5.47	18.67	8.29	28.29	5.80	19.80	8.54	29.14	4.61	15.73
					24	75.2	7.37	25.15	5.90	20.12	8.38	28.58	6.11	20.86	8.63	29.43	5.09	17.37
					27	80.6	7.44	25.40	6.03	20.58	8.46	28.87	6.43	21.94	8.71	29.73	5.66	19.33
					31	87.8	7.52	25.66	6.32	21.55	8.54	29.15	6.75	23.03	8.80	30.03	6.16	21.02
Medium	1400	824	0	0	23	73.4	7.08	24.15	5.31	18.11	8.04	27.44	5.63	19.21	8.28	28.26	4.47	15.26
					24	75.2	7.15	24.39	5.72	19.51	8.12	27.72	5.93	20.24	8.37	28.55	4.94	16.85
					27	80.6	7.22	24.64	5.85	19.96	8.21	28.00	6.24	21.28	8.45	28.84	5.49	18.75
					31	87.8	7.29	24.89	6.13	20.90	8.29	28.28	6.55	22.34	8.54	29.13	5.98	20.39
Low	1350	795	0	0	23	73.4	6.71	22.90	4.36	14.89	7.63	26.03	5.34	18.22	7.86	26.81	3.93	13.40
					24	75.2	6.78	23.14	4.81	16.43	7.71	26.29	5.62	19.19	7.94	27.08	4.37	14.89
					27	80.6	6.85	23.37	4.93	16.83	7.78	26.56	5.92	20.18	8.02	27.35	4.81	16.41
					31	87.8	6.92	23.60	5.12	17.47	7.86	26.82	6.21	21.19	8.10	27.63	5.26	17.96

Fan Speed	Air Flow Rate		ESP		Entering Air DBT		Outdoor Air Dry Bulb Temperature 110°F(43°C)											
							Indoor Air Wet Bulb Temperature °F(°C)											
					62°F(17°C)				67°F(19°C)				72°F(22°C)					
	m³/hr	cfm	Pa	in.wg	°C	°F	Total Capacity		Sensible Capacity		Total Capacity		Sensible Capacity		Total Capacity		Sensible Capacity	
High	1500	883	0	0	23	73.4	6.57	22.40	4.92	16.80	7.46	25.46	5.22	17.82	7.69	26.22	4.15	14.16
					24	75.2	6.63	22.63	5.31	18.11	7.54	25.72	5.50	18.78	7.76	26.49	4.58	15.63
					27	80.6	6.70	22.86	5.43	18.52	7.61	25.98	5.79	19.74	7.84	26.76	5.10	17.39
					31	87.8	6.77	23.09	5.68	19.40	7.69	26.24	6.08	20.73	7.92	27.03	5.54	18.92
Medium	1400	824	0	0	23	73.4	6.37	21.73	4.78	16.30	7.24	24.70	5.07	17.29	7.46	25.44	4.03	13.74
					24	75.2	6.43	21.95	5.15	17.56	7.31	24.95	5.34	18.21	7.53	25.70	4.44	15.16
					27	80.6	6.50	22.18	5.26	17.96	7.39	25.20	5.61	19.15	7.61	25.96	4.94	16.87
					31	87.8	6.56	22.40	5.51	18.81	7.46	25.45	5.89	20.11	7.68	26.22	5.38	18.35
Low	1350	795	0	0	23	73.4	6.04	20.61	3.93	13.40	6.86	23.42	4.81	16.40	7.07	24.13	3.54	12.06
					24	75.2	6.10	20.82	4.33	14.78	6.93	23.66	5.06	17.27	7.14	24.37	3.93	13.40
					27	80.6	6.16	21.03	4.44	15.14	7.00	23.90	5.32	18.16	7.22	24.62	4.33	14.77
					31	87.8	6.23	21.24	4.61	15.72	7.07	24.14	5.59	19.07	7.29	24.86	4.74	16.16

GTH36K3FI:

Fan Speed	Air Flow Rate		ESP		Entering Air DBT		Outdoor Air Dry Bulb Temperature 77°F(25°C)											
							Indoor Air Wet Bulb Temperature °F(°C)											
					62°F(17°C)				67°F(19°C)				72°F(22°C)					
	m³/hr	cfm	Pa	in.wg	°C	°F	Total Capacity		Sensible Capacity		Total Capacity		Sensible Capacity		Total Capacity		Sensible Capacity	
High	1900	1118	0	0	23	73.4	9.88	33.73	7.41	25.30	11.23	38.33	7.86	26.83	11.57	39.48	6.25	21.32
					24	75.2	9.99	34.07	7.99	27.26	11.35	38.72	8.28	28.26	11.69	39.88	6.90	23.53
					27	80.6	10.09	34.42	8.17	27.88	11.46	39.11	8.71	29.72	11.81	40.28	7.67	26.18
					31	87.8	10.19	34.76	8.56	29.20	11.58	39.50	9.15	31.20	11.92	40.68	8.35	28.48
Medium	1800	1059	0	0	23	73.4	9.59	32.72	7.19	24.54	10.90	37.18	7.63	26.02	11.22	38.29	6.06	20.68
					24	75.2	9.69	33.05	7.75	26.44	11.01	37.56	8.04	27.42	11.34	38.68	6.69	22.82
					27	80.6	9.78	33.38	7.93	27.04	11.12	37.94	8.45	28.83	11.45	39.07	7.44	25.40
					31	87.8	9.88	33.72	8.30	28.32	11.23	38.31	8.87	30.27	11.57	39.46	8.10	27.62
Low	1400	824	0	0	23	73.4	9.09	31.03	5.91	20.17	10.33	35.26	7.23	24.68	10.64	36.32	5.32	18.16
					24	75.2	9.19	31.35	6.52	22.26	10.44	35.62	7.00	23.88	10.75	36.69	5.91	20.18
					27	80.6	9.28	31.66	6.68	22.80	10.55	35.98	8.01	27.34	10.86	37.06	6.52	22.24
					31	87.8	9.37	31.98	6.94	23.66	10.65	36.34	8.41	28.71	10.97	37.43	7.13	24.33

Fan Speed	Air Flow Rate		ESP		Entering Air DBT		Outdoor Air Dry Bulb Temperature 95°F(35°C)											
							Indoor Air Wet Bulb Temperature °F(°C)											
	m ³ /hr cfm		Pa in.wg		°C °F		62°F(17°C)				67°F(19°C)				72°F(22°C)			
							Total Capacity		Sensible Capacity		Total Capacity		Sensible Capacity		Total Capacity		Sensible Capacity	
						kW	Mbh	kW	Mbh	kW	Mbh	kW	Mbh	kW	Mbh	kW	Mbh	
High	1900	1118	0	0	23	73.4	8.99	30.66	6.74	23.00	10.21	34.84	7.15	24.39	10.52	35.89	5.68	19.38
					24	75.2	9.08	30.97	7.26	24.78	10.32	35.20	7.53	25.69	10.63	36.25	6.27	21.39
					27	80.6	9.17	31.29	7.43	25.34	10.42	35.55	7.92	27.02	10.73	36.62	6.98	23.80
					31	87.8	9.26	31.60	7.78	26.54	10.52	35.91	8.31	28.37	10.84	36.99	7.59	25.89
Medium	1800	1059	0	0	23	73.4	8.72	29.74	6.54	22.31	9.91	33.80	6.93	23.66	10.20	34.81	5.51	18.80
					24	75.2	8.81	30.04	7.04	24.04	10.01	34.14	7.30	24.92	10.31	35.17	6.08	20.75
					27	80.6	8.89	30.35	7.20	24.58	10.11	34.49	7.68	26.21	10.41	35.52	6.77	23.09
					31	87.8	8.98	30.65	7.55	25.75	10.21	34.83	8.06	27.52	10.51	35.88	7.36	25.11
Low	1400	824	0	0	23	73.4	8.27	28.21	5.37	18.34	9.39	32.05	6.58	22.44	9.68	33.02	4.84	16.51
					24	75.2	8.35	28.50	5.93	20.23	9.49	32.38	6.93	23.64	9.78	33.35	5.38	18.34
					27	80.6	8.44	28.78	6.07	20.72	9.59	32.71	7.29	24.86	9.87	33.69	5.92	20.21
					31	87.8	8.52	29.07	6.31	21.51	9.68	33.04	7.65	26.10	9.97	34.03	6.48	22.12

Fan Speed	Air Flow Rate		ESP		Entering Air DBT		Outdoor Air Dry Bulb Temperature 110°F(43°C)											
							Indoor Air Wet Bulb Temperature °F(°C)											
	m ³ /hr cfm		Pa in.wg		°C °F		62°F(17°C)				67°F(19°C)				72°F(22°C)			
							Total Capacity		Sensible Capacity		Total Capacity		Sensible Capacity		Total Capacity		Sensible Capacity	
						kW	Mbh	kW	Mbh	kW	Mbh	kW	Mbh	kW	Mbh	kW	Mbh	
High	1900	1118	0	0	23	73.4	8.09	27.59	6.07	20.70	9.19	31.36	6.43	21.95	9.47	32.30	5.11	17.44
					24	75.2	8.17	27.88	6.54	22.30	9.28	31.68	6.78	23.12	9.56	32.63	5.64	19.25
					27	80.6	8.25	28.16	6.68	22.81	9.38	32.00	7.13	24.32	9.66	32.96	6.28	21.42
					31	87.8	8.34	28.44	7.00	23.89	9.47	32.32	7.48	25.53	9.76	33.29	6.83	23.30
Medium	1800	1059	0	0	23	73.4	7.84	26.77	5.88	20.08	8.91	30.42	6.24	21.29	9.18	31.33	4.96	16.92
					24	75.2	7.93	27.04	6.34	21.63	9.01	30.73	6.57	22.43	9.28	31.65	5.47	18.67
					27	80.6	8.01	27.31	6.48	22.12	9.10	31.04	6.91	23.59	9.37	31.97	6.09	20.78
					31	87.8	8.09	27.59	6.79	23.17	9.19	31.35	7.26	24.77	9.46	32.29	6.62	22.60
Low	1400	824	0	0	23	73.4	7.44	25.39	4.84	16.50	8.46	28.85	5.92	20.19	8.71	29.71	4.35	14.86
					24	75.2	7.52	25.65	5.34	18.21	8.54	29.14	6.24	21.27	8.80	30.02	4.84	16.51
					27	80.6	7.59	25.91	5.47	18.65	8.63	29.44	6.56	22.37	8.89	30.32	5.33	18.19
					31	87.8	7.67	26.16	5.67	19.36	8.71	29.73	6.88	23.49	8.98	30.62	5.83	19.91

GTH42K3FI:

Fan Speed	Air Flow Rate		ESP		Entering Air DBT		Outdoor Air Dry Bulb Temperature 77°F(25°C)											
							Indoor Air Wet Bulb Temperature °F(°C)											
	m ³ /hr cfm		Pa in.wg		°C °F		62°F(17°C)				67°F(19°C)				72°F(22°C)			
							Total Capacity		Sensible Capacity		Total Capacity		Sensible Capacity		Total Capacity		Sensible Capacity	
						kW	Mbh	kW	Mbh	kW	Mbh	kW	Mbh	kW	Mbh	kW	Mbh	
High	1900	1118	0	0	23	73.4	10.83	36.96	8.13	27.72	12.31	42.00	8.62	29.40	12.68	43.26	6.85	23.36
					24	75.2	10.94	37.34	8.76	29.87	12.44	42.43	9.08	30.98	12.81	43.71	7.56	25.79
					27	80.6	11.05	37.72	8.95	30.55	12.56	42.86	9.55	32.57	12.94	44.15	8.41	28.70
					31	87.8	11.17	38.10	9.38	32.00	12.69	43.29	10.02	34.20	13.07	44.59	9.15	31.21
Medium	1800	1059	0	0	23	73.4	10.51	35.85	7.88	26.89	11.94	40.74	8.36	28.52	12.30	41.97	6.64	22.66
					24	75.2	10.62	36.22	8.49	28.98	12.06	41.16	8.81	30.05	12.43	42.39	7.33	25.01
					27	80.6	10.72	36.59	8.69	29.64	12.19	41.58	9.26	31.60	12.55	42.82	8.16	27.83
					31	87.8	10.83	36.95	9.10	31.04	12.31	41.99	9.72	33.17	12.68	43.25	8.87	30.28
Low	1400	824	0	0	23	73.4	9.97	34.01	6.48	22.10	11.33	38.64	7.93	27.05	11.67	39.80	5.83	19.90
					24	75.2	10.07	34.35	7.15	24.39	11.44	39.04	7.67	26.17	11.78	40.21	6.48	22.12
					27	80.6	10.17	34.70	7.32	24.98	11.56	39.43	8.78	29.97	11.90	40.62	7.14	24.37
					31	87.8	10.27	35.05	7.60	25.94	11.67	39.83	9.22	31.46	12.02	41.02	7.81	26.66

DC Inverter U-match Air Conditioners Technical Sales Guide

Fan Speed	Air Flow Rate		ESP		Entering Air DBT		Outdoor Air Dry Bulb Temperature 95°F(35°C)											
							Indoor Air Wet Bulb Temperature °F(°C)											
					62°F(17°C)				67°F(19°C)				72°F(22°C)					
	m ³ /hr	cfm	Pa	in.wg	°C	°F	Total Capacity		Sensible Capacity		Total Capacity		Sensible Capacity		Total Capacity		Sensible Capacity	
High	1900	1118	0	0	23	73.4	9.85	33.60	7.39	25.20	11.19	38.19	7.83	26.73	11.53	39.33	6.22	21.24
					24	75.2	9.95	33.95	7.96	27.16	11.31	38.58	8.25	28.16	11.64	39.73	6.87	23.44
					27	80.6	10.05	34.29	8.14	27.77	11.42	38.97	8.68	29.61	11.76	40.13	7.65	26.09
					31	87.8	10.15	34.63	8.53	29.09	11.53	39.35	9.11	31.09	11.88	40.54	8.32	28.37
Medium	1800	1059	0	0	23	73.4	9.55	32.60	7.16	24.45	10.86	37.04	7.60	25.93	11.18	38.15	6.04	20.60
					24	75.2	9.65	32.93	7.72	26.34	10.97	37.42	8.01	27.32	11.30	38.54	6.66	22.74
					27	80.6	9.75	33.26	7.90	26.94	11.08	37.80	8.42	28.73	11.41	38.93	7.42	25.30
					31	87.8	9.85	33.59	8.27	28.22	11.19	38.17	8.84	30.16	11.52	39.32	8.07	27.52
Low	1400	824	0	0	23	73.4	9.06	30.92	5.89	20.09	10.30	35.13	7.21	24.59	10.61	36.18	5.30	18.09
					24	75.2	9.15	31.23	6.50	22.17	10.40	35.49	7.59	25.91	10.71	36.55	5.89	20.10
					27	80.6	9.25	31.55	6.66	22.71	10.51	35.85	7.98	27.24	10.82	36.92	6.49	22.15
					31	87.8	9.34	31.86	6.91	23.58	10.61	36.21	8.38	28.60	10.93	37.29	7.10	24.24

Fan Speed	Air Flow Rate		ESP		Entering Air DBT		Outdoor Air Dry Bulb Temperature 110°F(43°C)											
							Indoor Air Wet Bulb Temperature °F(°C)											
					62°F(17°C)				67°F(19°C)				72°F(22°C)					
	m ³ /hr	cfm	Pa	in.wg	°C	°F	Total Capacity		Sensible Capacity		Total Capacity		Sensible Capacity		Total Capacity		Sensible Capacity	
High	1900	1118	0	0	23	73.4	8.86	30.24	6.65	22.68	10.07	34.37	7.05	24.06	10.37	35.40	5.60	19.12
					24	75.2	8.95	30.55	7.16	24.44	10.18	34.72	7.43	25.34	10.48	35.76	6.18	21.10
					27	80.6	9.04	30.86	7.33	25.00	10.28	35.07	7.81	26.65	10.59	36.12	6.88	23.48
					31	87.8	9.14	31.17	7.67	26.18	10.38	35.42	8.20	27.98	10.69	36.48	7.48	25.54
Medium	1800	1059	0	0	23	73.4	8.60	29.34	6.45	22.00	9.77	33.34	6.84	23.34	10.06	34.34	5.43	18.54
					24	75.2	8.69	29.64	6.95	23.71	9.87	33.68	7.21	24.58	10.17	34.69	6.00	20.47
					27	80.6	8.77	29.93	7.11	24.25	9.97	34.02	7.58	25.85	10.27	35.04	6.67	22.77
					31	87.8	8.86	30.23	7.44	25.40	10.07	34.36	7.95	27.14	10.37	35.39	7.26	24.77
Low	1400	824	0	0	23	73.4	8.15	27.82	5.30	18.09	9.27	31.62	6.49	22.13	9.54	32.57	4.77	16.28
					24	75.2	8.24	28.11	5.85	19.96	9.36	31.94	6.83	23.32	9.64	32.90	5.30	18.09
					27	80.6	8.32	28.39	5.99	20.44	9.46	32.26	7.19	24.52	9.74	33.23	5.84	19.94
					31	87.8	8.40	28.68	6.22	21.22	9.55	32.59	7.54	25.74	9.84	33.56	6.39	21.82

GTH48K3FI:

Fan Speed	Air Flow Rate		ESP		Entering Air DBT		Outdoor Air Dry Bulb Temperature 77°F(25°C)											
							Indoor Air Wet Bulb Temperature °F(°C)											
					62°F(17°C)				67°F(19°C)				72°F(22°C)					
	m ³ /hr	cfm	Pa	in.wg	°C	°F	Total Capacity		Sensible Capacity		Total Capacity		Sensible Capacity		Total Capacity		Sensible Capacity	
High	2300	1354	0	0	23	73.4	13.22	45.12	9.92	33.84	15.03	51.27	10.52	35.89	15.48	52.81	8.36	28.52
					24	75.2	13.36	45.58	10.69	36.46	15.18	51.80	11.08	37.81	15.64	53.35	9.23	31.48
					27	80.6	13.49	46.04	10.93	37.29	15.33	52.32	11.65	39.76	15.79	53.89	10.27	35.03
					31	87.8	13.63	46.50	11.45	39.06	15.49	52.84	12.23	41.75	15.95	54.43	11.17	38.10
Medium	2100	1236	0	0	23	73.4	12.83	43.77	9.62	32.83	14.58	49.74	10.20	34.81	15.01	51.23	8.11	27.66
					24	75.2	12.96	44.21	10.37	35.37	14.73	50.24	10.75	36.68	15.17	51.75	8.95	30.53
					27	80.6	13.09	44.66	10.60	36.17	14.87	50.75	11.30	38.57	15.32	52.27	9.96	33.98
					31	87.8	13.22	45.11	11.10	37.89	15.02	51.26	11.87	40.49	15.47	52.80	10.83	36.96
Low	1800	1059	0	0	23	73.4	12.17	41.51	7.91	26.98	13.83	47.17	9.68	33.02	14.24	48.59	7.12	24.29
					24	75.2	12.29	41.93	8.73	29.77	13.97	47.65	9.36	31.94	14.39	49.08	7.91	27.00
					27	80.6	12.41	42.36	8.94	30.50	14.11	48.13	10.72	36.58	14.53	49.58	8.72	29.75
					31	87.8	12.54	42.78	9.28	31.66	14.25	48.62	11.26	38.41	14.68	50.07	9.54	32.55

Fan Speed	Air Flow Rate		ESP		Entering Air DBT		Outdoor Air Dry Bulb Temperature 95°F(35°C)											
							Indoor Air Wet Bulb Temperature °F(°C)											
							62°F(17°C)				67°F(19°C)				72°F(22°C)			
	m ³ /hr	cfm	Pa	in.wg	°C	°F	Total Capacity		Sensible Capacity		Total Capacity		Sensible Capacity		Total Capacity		Sensible Capacity	
High	2300	1354	0	0	23	73.4	12.02	41.02	9.02	30.76	13.66	46.61	9.56	32.63	14.07	48.01	7.60	25.93
					24	75.2	12.14	41.44	9.72	33.15	13.80	47.09	10.07	34.37	14.21	48.50	8.39	28.62
					27	80.6	12.27	41.86	9.94	33.90	13.94	47.56	10.59	36.15	14.36	48.99	9.33	31.84
					31	87.8	12.39	42.27	10.41	35.51	14.08	48.04	11.12	37.95	14.50	49.48	10.15	34.64
Medium	2100	1236	0	0	23	73.4	11.66	39.79	8.75	29.84	13.25	45.21	9.28	31.65	13.65	46.57	7.37	25.15
					24	75.2	11.78	40.19	9.42	32.16	13.39	45.68	9.77	33.34	13.79	47.05	8.14	27.76
					27	80.6	11.90	40.60	9.64	32.89	13.52	46.14	10.28	35.06	13.93	47.52	9.05	30.89
					31	87.8	12.02	41.01	10.10	34.45	13.66	46.60	10.79	36.81	14.07	48.00	9.85	33.60
Low	1800	1059	0	0	23	73.4	11.06	37.74	7.19	24.53	12.57	42.88	8.80	30.02	12.95	44.17	6.47	22.08
					24	75.2	11.17	38.12	7.93	27.07	12.70	43.32	9.27	31.62	13.08	44.62	7.19	24.54
					27	80.6	11.29	38.51	8.13	27.73	12.82	43.76	9.75	33.26	13.21	45.07	7.93	27.04
					31	87.8	11.40	38.89	8.44	28.78	12.95	44.20	10.23	34.91	13.34	45.52	8.67	29.59

Fan Speed	Air Flow Rate		ESP		Entering Air DBT		Outdoor Air Dry Bulb Temperature 110°F(43°C)											
							Indoor Air Wet Bulb Temperature °F(°C)											
							62°F(17°C)				67°F(19°C)				72°F(22°C)			
	m ³ /hr	cfm	Pa	in.wg	°C	°F	Total Capacity		Sensible Capacity		Total Capacity		Sensible Capacity		Total Capacity		Sensible Capacity	
High	2300	1354	0	0	23	73.4	10.82	36.92	8.11	27.69	12.30	41.95	8.61	29.37	12.66	43.21	6.84	23.33
					24	75.2	10.93	37.29	8.74	29.83	12.42	42.38	9.07	30.94	12.79	43.65	7.55	25.75
					27	80.6	11.04	37.67	8.94	30.51	12.55	42.81	9.53	32.53	12.92	44.09	8.40	28.66
					31	87.8	11.15	38.05	9.37	31.96	12.67	43.24	10.01	34.16	13.05	44.53	9.14	31.17
Medium	2100	1236	0	0	23	73.4	10.50	35.81	7.87	26.86	11.93	40.69	8.35	28.48	12.28	41.91	6.63	22.63
					24	75.2	10.60	36.17	8.48	28.94	12.05	41.11	8.79	30.01	12.41	42.34	7.32	24.98
					27	80.6	10.71	36.54	8.67	29.60	12.17	41.52	9.25	31.56	12.53	42.77	8.15	27.80
					31	87.8	10.82	36.91	9.09	31.00	12.29	41.94	9.71	33.13	12.66	43.20	8.86	30.24
Low	1800	1059	0	0	23	73.4	9.95	33.96	6.47	22.08	11.31	38.59	7.92	27.02	11.65	39.75	5.83	19.88
					24	75.2	10.06	34.31	7.14	24.36	11.43	38.99	8.34	28.46	11.77	40.16	6.47	22.09
					27	80.6	10.16	34.66	7.31	24.95	11.54	39.38	8.77	29.93	11.89	40.56	7.13	24.34
					31	87.8	10.26	35.00	7.59	25.90	11.66	39.78	9.21	31.42	12.01	40.97	7.80	26.63

GTH60K3FI:

Fan Speed	Air Flow Rate		ESP		Entering Air DBT		Outdoor Air Dry Bulb Temperature 77°F(25°C)											
							Indoor Air Wet Bulb Temperature °F(°C)											
							62°F(17°C)				67°F(19°C)				72°F(22°C)			
	m ³ /hr	cfm	Pa	in.wg	°C	°F	Total Capacity		Sensible Capacity		Total Capacity		Sensible Capacity		Total Capacity		Sensible Capacity	
High	2500	1471	0	0	23	73.4	15.41	52.56	11.55	39.42	17.51	59.73	12.25	41.81	18.03	61.52	9.74	33.22
					24	75.2	15.56	53.10	12.45	42.48	17.69	60.34	12.91	44.05	18.22	62.15	10.75	36.67
					27	80.6	15.72	53.64	12.73	43.45	17.86	60.95	13.58	46.32	18.40	62.78	11.96	40.81
					31	87.8	15.88	54.17	13.34	45.51	18.04	61.56	14.25	48.63	18.58	63.41	13.01	44.39
Medium	2300	1354	0	0	23	73.4	14.94	50.99	11.21	38.24	16.98	57.94	11.89	40.56	17.49	59.68	9.45	32.23
					24	75.2	15.10	51.51	12.08	41.21	17.15	58.53	12.52	42.73	17.67	60.29	10.42	35.57
					27	80.6	15.25	52.03	12.35	42.14	17.33	59.12	13.17	44.93	17.85	60.90	11.60	39.58
					31	87.8	15.40	52.55	12.94	44.14	17.50	59.71	13.83	47.17	18.03	61.51	12.62	43.05
Low	2100	1236	0	0	23	73.4	14.17	48.36	9.21	31.43	16.11	54.95	11.27	38.47	16.59	56.60	8.29	28.30
					24	75.2	14.32	48.85	10.17	34.69	16.27	55.52	10.91	37.21	16.76	57.18	9.22	31.45
					27	80.6	14.46	49.35	10.41	35.53	16.43	56.08	12.49	42.62	16.93	57.76	10.16	34.65
					31	87.8	14.61	49.84	10.81	36.88	16.60	56.64	13.11	44.74	17.10	58.34	11.11	37.92

DC Inverter U-match Air Conditioners Technical Sales Guide

Fan Speed	Air Flow Rate		ESP		Entering Air DBT		Outdoor Air Dry Bulb Temperature 95°F(35°C)											
							Indoor Air Wet Bulb Temperature °F(°C)											
					62°F(17°C)				67°F(19°C)				72°F(22°C)					
	m ³ /hr	cfm	Pa	in.wg	°C	°F	Total Capacity		Sensible Capacity		Total Capacity		Sensible Capacity		Total Capacity		Sensible Capacity	
High	2500	1471	0	0	23	73.4	14.01	47.79	10.50	35.84	15.92	54.30	11.14	38.01	16.39	55.93	8.85	30.20
					24	75.2	14.15	48.27	11.32	38.62	16.08	54.86	11.74	40.05	16.56	56.50	9.77	33.34
					27	80.6	14.29	48.76	11.58	39.50	16.24	55.41	12.34	42.11	16.73	57.07	10.87	37.10
					31	87.8	14.43	49.25	12.12	41.37	16.40	55.96	12.96	44.21	16.89	57.64	11.83	40.35
Medium	2300	1354	0	0	23	73.4	13.59	46.35	10.19	34.76	15.44	52.67	10.81	36.87	15.90	54.25	8.59	29.30
					24	75.2	13.72	46.83	10.98	37.46	15.60	53.21	11.38	38.84	16.06	54.81	9.48	32.34
					27	80.6	13.86	47.30	11.23	38.31	15.75	53.75	11.97	40.85	16.23	55.36	10.55	35.98
					31	87.8	14.00	47.77	11.76	40.13	15.91	54.29	12.57	42.89	16.39	55.91	11.47	39.14
Low	2100	1236	0	0	23	73.4	12.88	43.96	8.38	28.58	14.64	49.96	10.25	34.97	15.08	51.46	7.54	25.73
					24	75.2	13.02	44.41	9.24	31.53	14.79	50.47	10.80	36.84	15.24	51.98	8.38	28.59
					27	80.6	13.15	44.86	9.47	32.30	14.94	50.98	11.36	38.74	15.39	52.51	9.23	31.50
					31	87.8	13.28	45.31	9.83	33.53	15.09	51.49	11.92	40.68	15.54	53.03	10.10	34.47

Fan Speed	Air Flow Rate		ESP		Entering Air DBT		Outdoor Air Dry Bulb Temperature 110°F(43°C)											
							Indoor Air Wet Bulb Temperature °F(°C)											
					62°F(17°C)				67°F(19°C)				72°F(22°C)					
	m ³ /hr	cfm	Pa	in.wg	°C	°F	Total Capacity		Sensible Capacity		Total Capacity		Sensible Capacity		Total Capacity		Sensible Capacity	
High	2500	1471	0	0	23	73.4	12.60	43.01	9.45	32.26	14.32	48.87	10.03	34.21	14.75	50.34	7.97	27.18
					24	75.2	12.73	43.45	10.19	34.76	14.47	49.37	10.56	36.04	14.90	50.85	8.79	30.00
					27	80.6	12.86	43.89	10.42	35.55	14.62	49.87	11.11	37.90	15.05	51.37	9.79	33.39
					31	87.8	12.99	44.32	10.91	37.23	14.76	50.37	11.66	39.79	15.21	51.88	10.64	36.32
Medium	2300	1354	0	0	23	73.4	12.23	41.72	9.17	31.29	13.89	47.41	9.73	33.18	14.31	48.83	7.73	26.37
					24	75.2	12.35	42.14	9.88	33.71	14.04	47.89	10.25	34.96	14.46	49.33	8.53	29.10
					27	80.6	12.48	42.57	10.11	34.48	14.18	48.37	10.77	36.76	14.60	49.82	9.49	32.39
					31	87.8	12.60	42.99	10.58	36.12	14.32	48.86	11.31	38.60	14.75	50.32	10.32	35.23
Low	2100	1236	0	0	23	73.4	11.60	39.57	7.54	25.72	13.18	44.96	9.22	31.47	13.57	46.31	6.79	23.16
					24	75.2	11.71	39.97	8.32	28.38	13.31	45.42	9.72	33.16	13.71	46.78	7.54	25.73
					27	80.6	11.83	40.37	8.52	29.07	13.45	45.88	10.22	34.87	13.85	47.26	8.31	28.35
					31	87.8	11.95	40.78	8.84	30.18	13.58	46.34	10.73	36.61	13.99	47.73	9.09	31.02



4 Electrical Data

Outdoor unit

Model	Compressor			Fan Motor	Fuse/Breaker Capacity	Min. Power Supply Cord
	Power Supply	Qty.	RLA	FLA		
	V/Ph/Hz	–	A	A	A	mm ²
GUHD09NK3FO	220-240,1,50	1	4.5	<1	15/13	1.5
GUHD12NK3FO	220-240,1,50	1	4.5	<1	15/13	1.5
GUHD18NK3FO	220-240,1,50	1	7.2	<1	15/16	1.5
GUHD24NK3FO	220-240,1,50	1	11.5	<1	30/20	2.5
GUHD30NK3FO	220-240,1,50	1	11.5	<1	30/20	2.5
GUHD36NK3FO	220-240,1,50	1	19	<1	30/25	2.5
GUHD42NK3FO	220-240,1,50	1	19	<1	30/25	2.5
GUHD48NK3FO	220-240,1,50	1	21	<1	-/40	6.0
GUHD36NM3FO	380-415,3,50	1	7.8	<1	-/16	1.5
GUHD42NM3FO	380-415,3,50	1	7.8	<1	-/16	1.5
GUHD48NM3FO	380-415,3,50	1	8	<1	-/16	1.5
GUHD60NM3FO	380-415,3,50	1	8	<1	-/16	1.5

Indoor unit

Model	Power Supply	Fan Motor FLA	Fuse/Breaker Capacity	Min. Power Supply Cord
	V/Ph/Hz	A	A	mm ²
GFH09K3FI	220-240,1,50	<1	5/6	1.0
GFH12K3FI	220-240,1,50	<1	5/6	1.0
GFH18K3FI	220-240,1,50	<1	5/6	1.0
GFH24K3FI	220-240,1,50	<1	5/6	1.0
GFH30K3FI	220-240,1,50	<1	5/6	1.0
GFH36K3FI	220-240,1,50	<1	5/6	1.0
GFH42K3FI	220-240,1,50	<1	5/6	1.0
GFH48K3FI	220-240,1,50	<1	5/6	1.0
GFH60K3FI	220-240,1,50	<1	5/6	1.0
GKH12K3FI	220-240,1,50	<1	5/6	1.0
GKH18K3FI	220-240,1,50	<1	5/6	1.0
GKH24K3FI	220-240,1,50	<1	5/6	1.0
GKH30K3FI	220-240,1,50	<1	5/6	1.0
GKH36K3FI	220-240,1,50	<1	5/6	1.0
GKH42K3FI	220-240,1,50	<1	5/6	1.0
GKH48K3FI	220-240,1,50	<1	5/6	1.0
GKH60K3FI	220-240,1,50	<1	5/6	1.0
GTH09K3FI	220-240,1,50	<1	5/6	1.0
GTH12K3FI	220-240,1,50	<1	5/6	1.0
GTH18K3FI	220-240,1,50	<1	5/6	1.0
GTH24K3FI	220-240,1,50	<1	5/6	1.0

GTH30K3FI	220-240,1,50	<1	5/6	1.0
GTH36K3FI	220-240,1,50	<1	5/6	1.0
GTH42K3FI	220-240,1,50	<1	5/6	1.0
GTH48K3FI	220-240,1,50	<1	5/6	1.0
GTH60K3FI	220-240,1,50	<1	5/6	1.0

Notes:

RLA:Rated load amperes

LRA:Locked rotor amperes

FLA:Full load current

Fuse: On the main board

- a. The specifications of the breaker and power cable listed in the table above are determined based on the maximum power (maximum amps) of the unit.
- b. The specifications of the power cable listed in the table above are applied to the conduit-guarded multi-wire copper cable (like, YJV copper cable, consisting of PE insulated wires and a PVC cable jacket) used at 40°C and resistible to 90°C (see IEC 60364-5-52). If the working condition changes, they should be modified according to the related national standard.
- c. The specifications of the breaker listed in the table above are applied to the breaker with the working temperature at 40°C. If the working condition changes, they should be modified according to the related national standard.

5 FAN CHARACTERISTICS

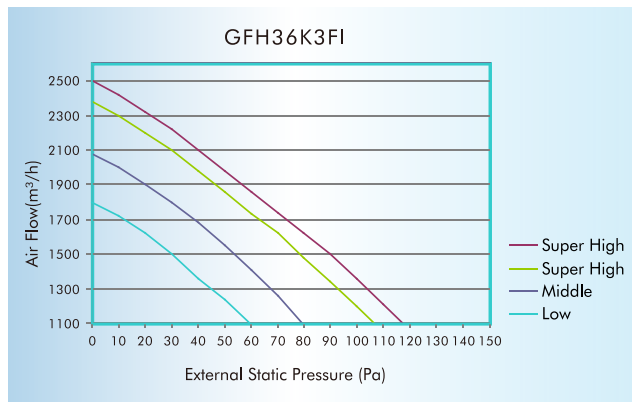
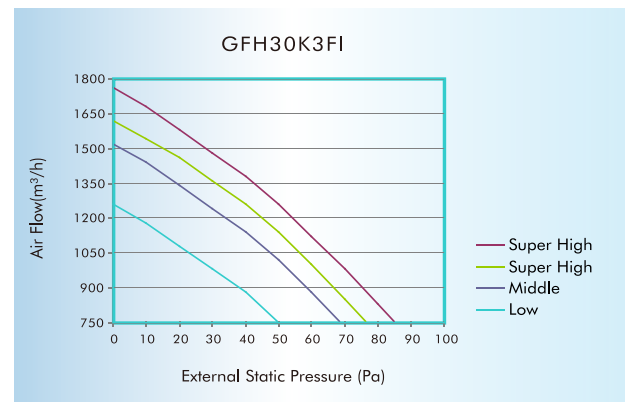
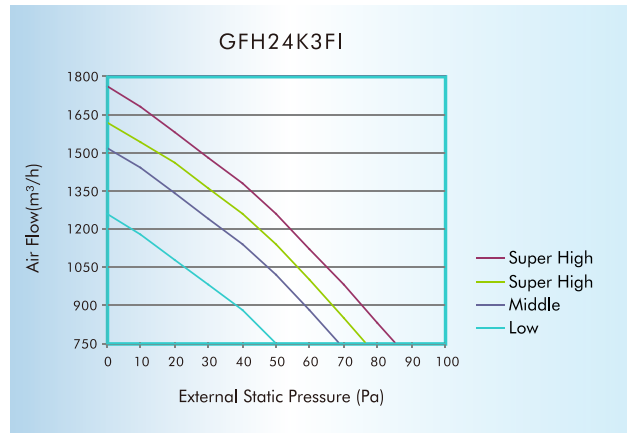
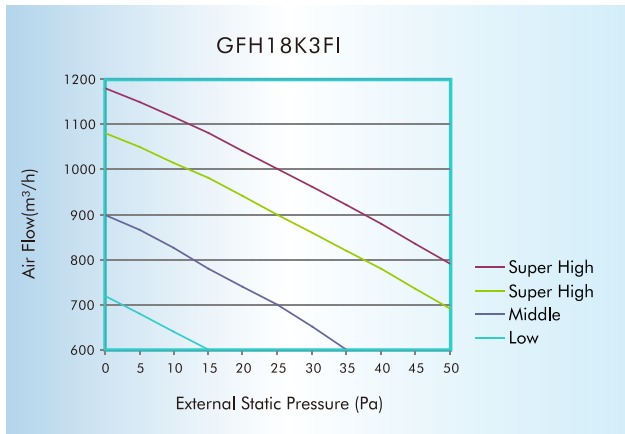
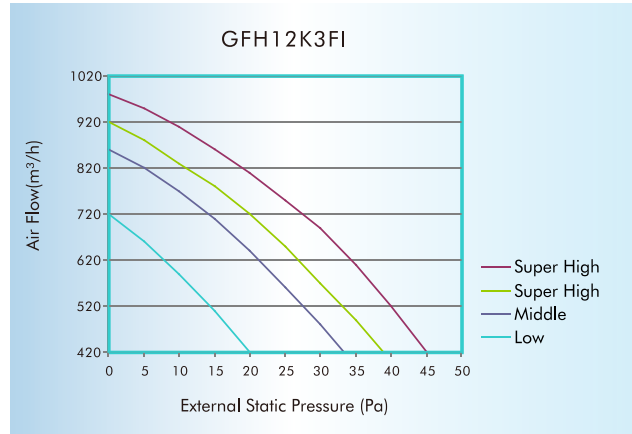
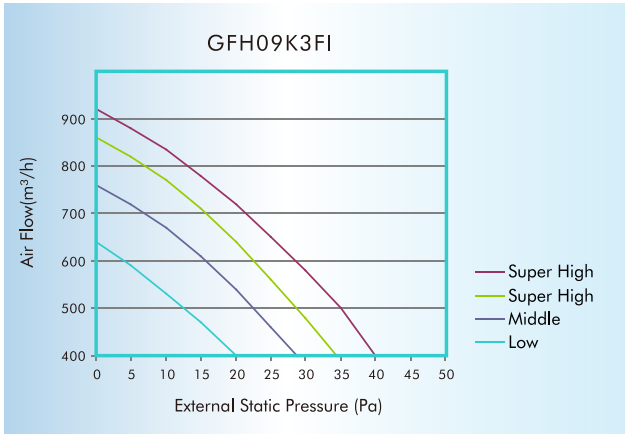

DC Inverter U-match Air Conditioners Technical Sales Guide

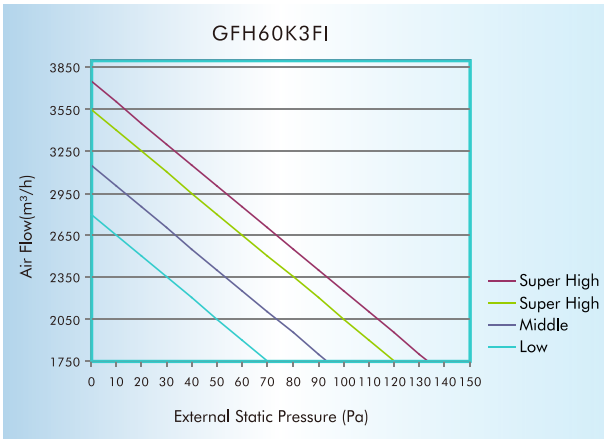
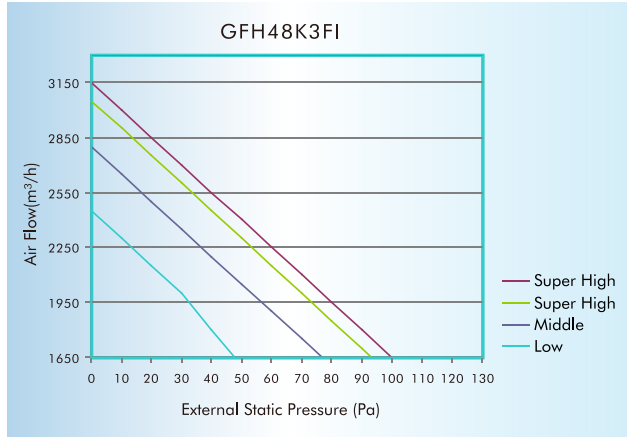
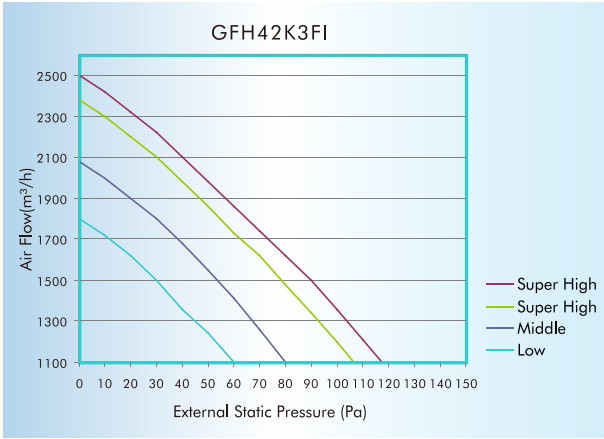

6 DIMENSION

6.1 Indoor Units

6.1.1 Duct type 2.6-5kw

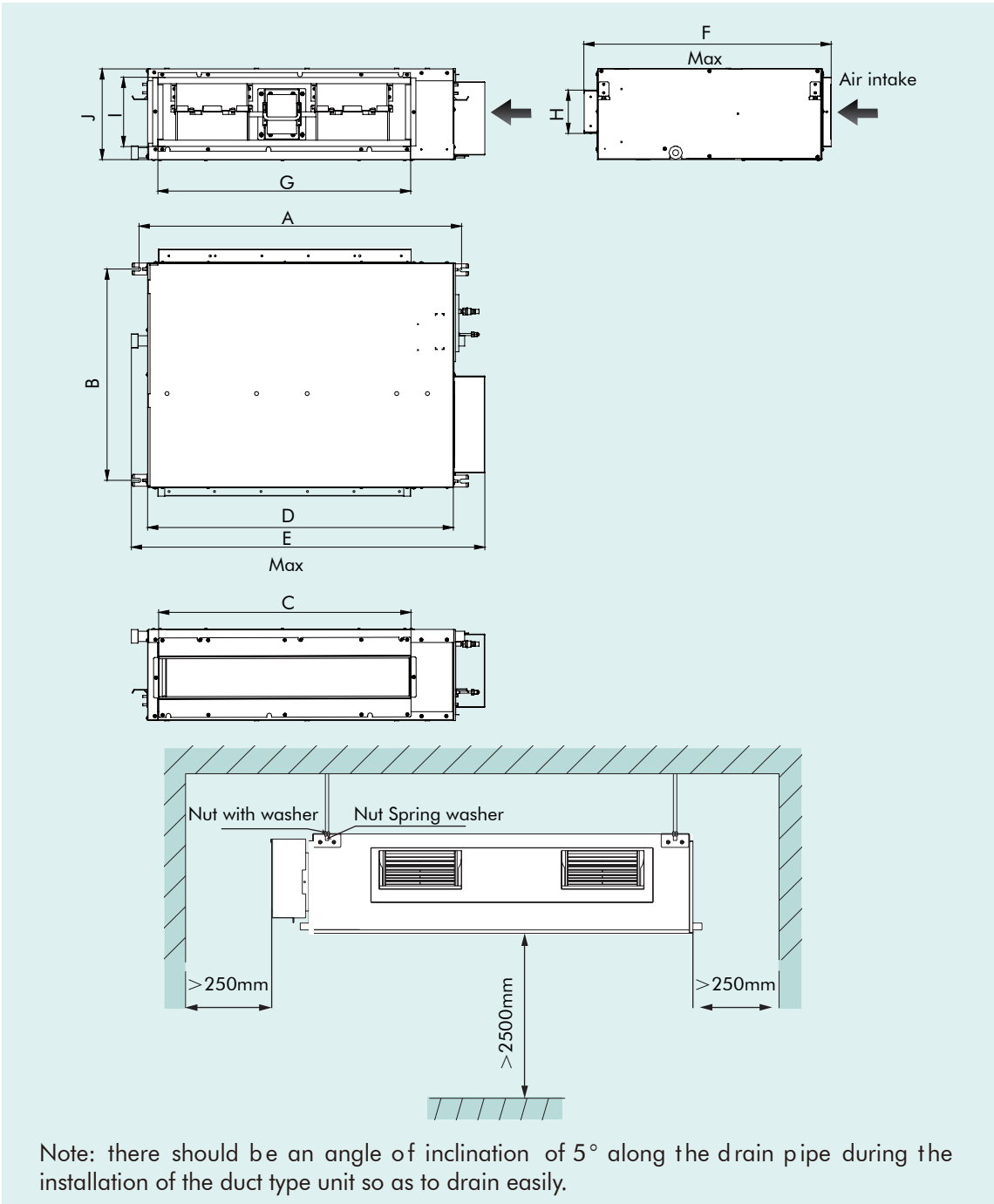

Note: there should be an angle of inclination of 5° along the drain pipe during the installation of the duct type unit so as to drain easily.

24-42kbtu/h:

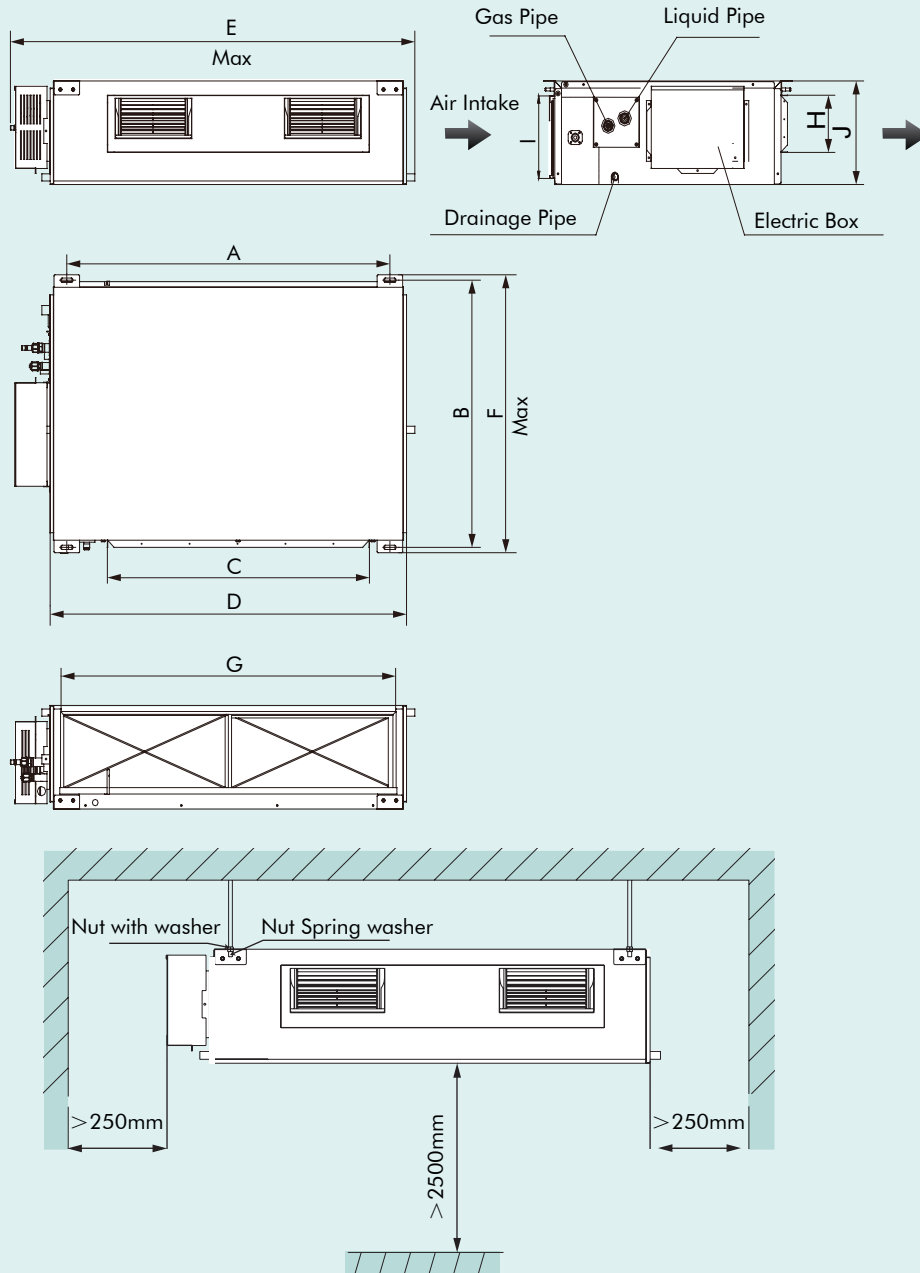

Note: there should be an angle of inclination of 5° along the drain pipe during the installation of the duct type unit so as to drain easily.

48-60kBtu/h:

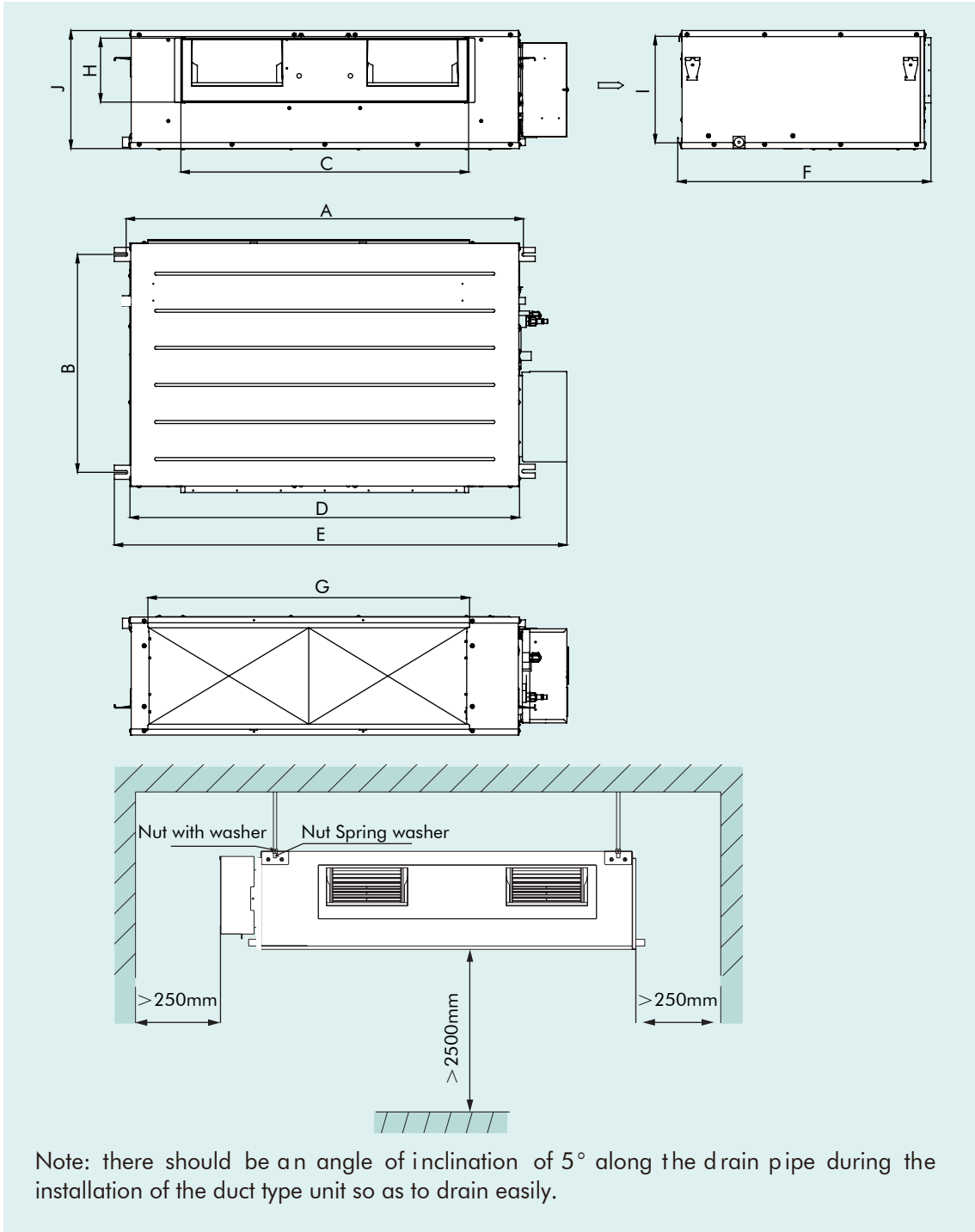

Unit: mm

Item	A	B	C	D	E	F	G	H	I	J
Model GFH09K3FI	840	561	635	790	925	665	738	125	203	250
GFH12K3FI	945	618	738	892	1037	721	738	125	203	266
GFH18K3FI										
GFH24K3FI	1101	517	820	1159	1279	558	1002	160	235	268
GFH30K3FI										
GFH36K3FI	1011	748	820	1115	1226	775	979	160	231	290
GFH42K3FI										
GFH48K3FI	1177	646	852	1150	1340	750	953	190	316	350
GFH60K3FI										

6.1.2 Floor-Ceiling type

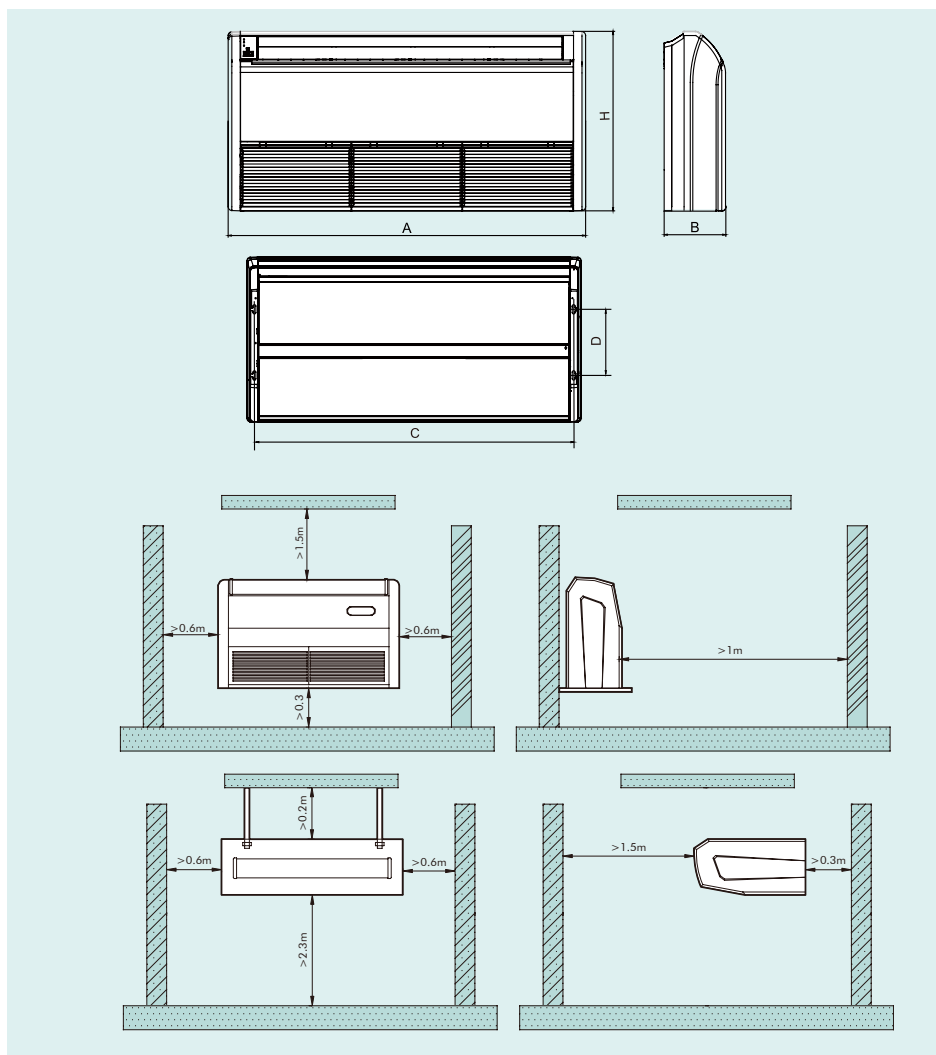

Unit: mm

Model	A	B	C	D	H
GTH09K3FI	1220	225	1158	280	700
GTH12K3FI					
GTH18K3FI					
GTH24K3FI					
GTH30K3FI	1420	245	1354	280	700
GTH36K3FI					
GTH42K3FI					
GTH48K3FI	1700	245	1634	280	700
GTH60K3FI					

6.1.3 Cassette type

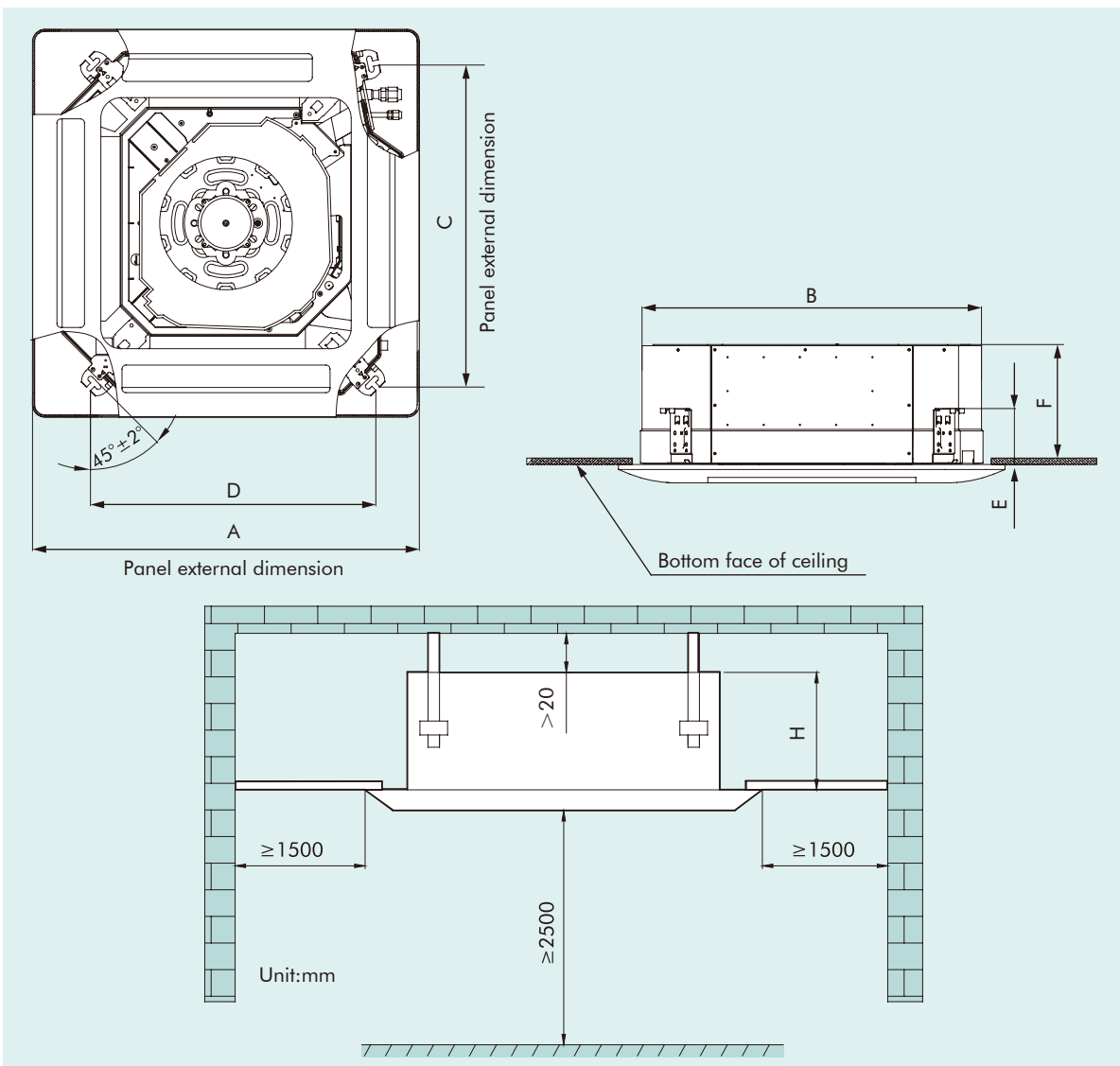

Unit: mm

Item Model	A	B	C	D	E	F	H
GKH12K3FI	670	596	592	571	145	240	255
GKH18K3FI							
GKH24K3FI	950	840	780	680	160	240	260
GKH30K3FI	950	840	780	680	160	320	340
GKH36K3FI							
GKH42K3FI							
GKH48K3FI	1040	910	842	788	170	290	320
GKH60K3FI							



6.2 Outdoor Units

Be suit for: 09~36(kBtu/h):

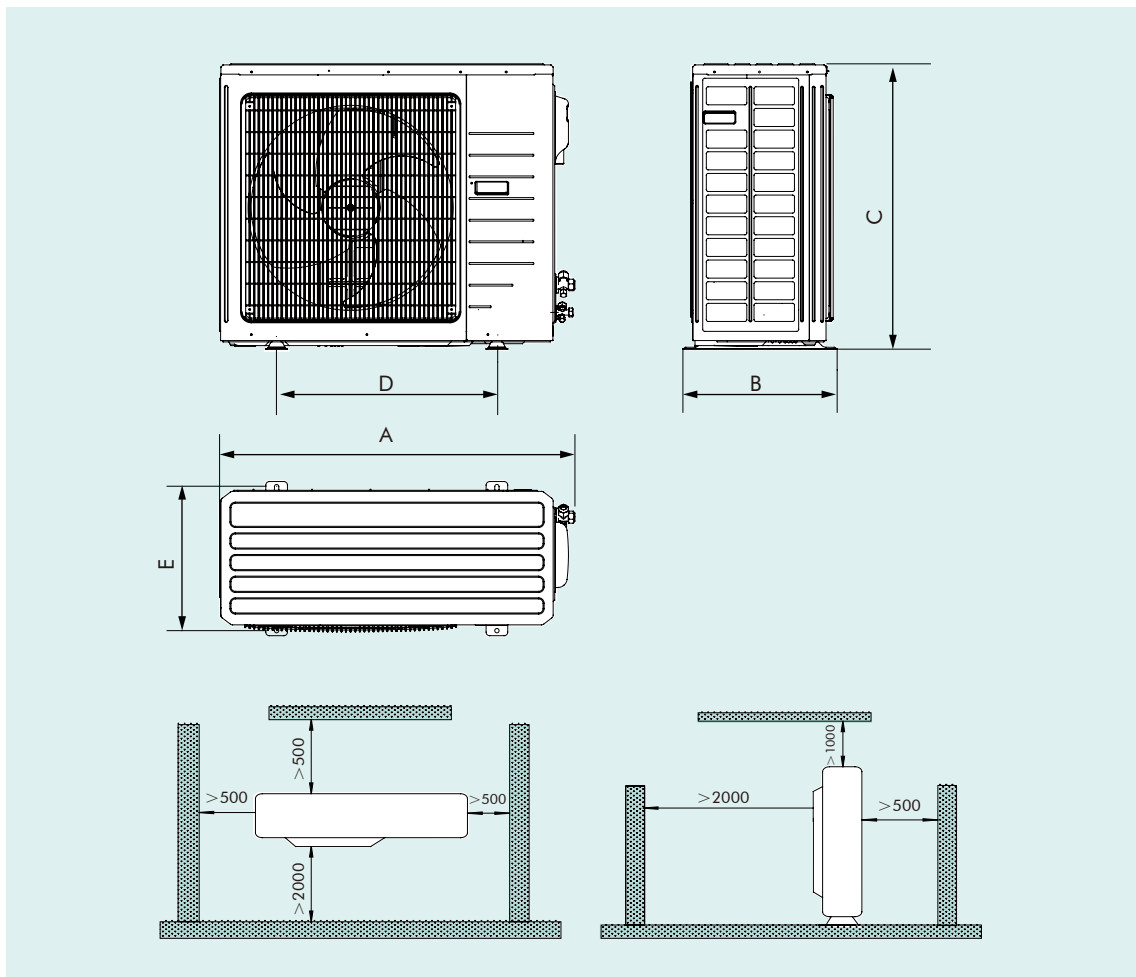

Be suit for: 42~60(kBtu/h):

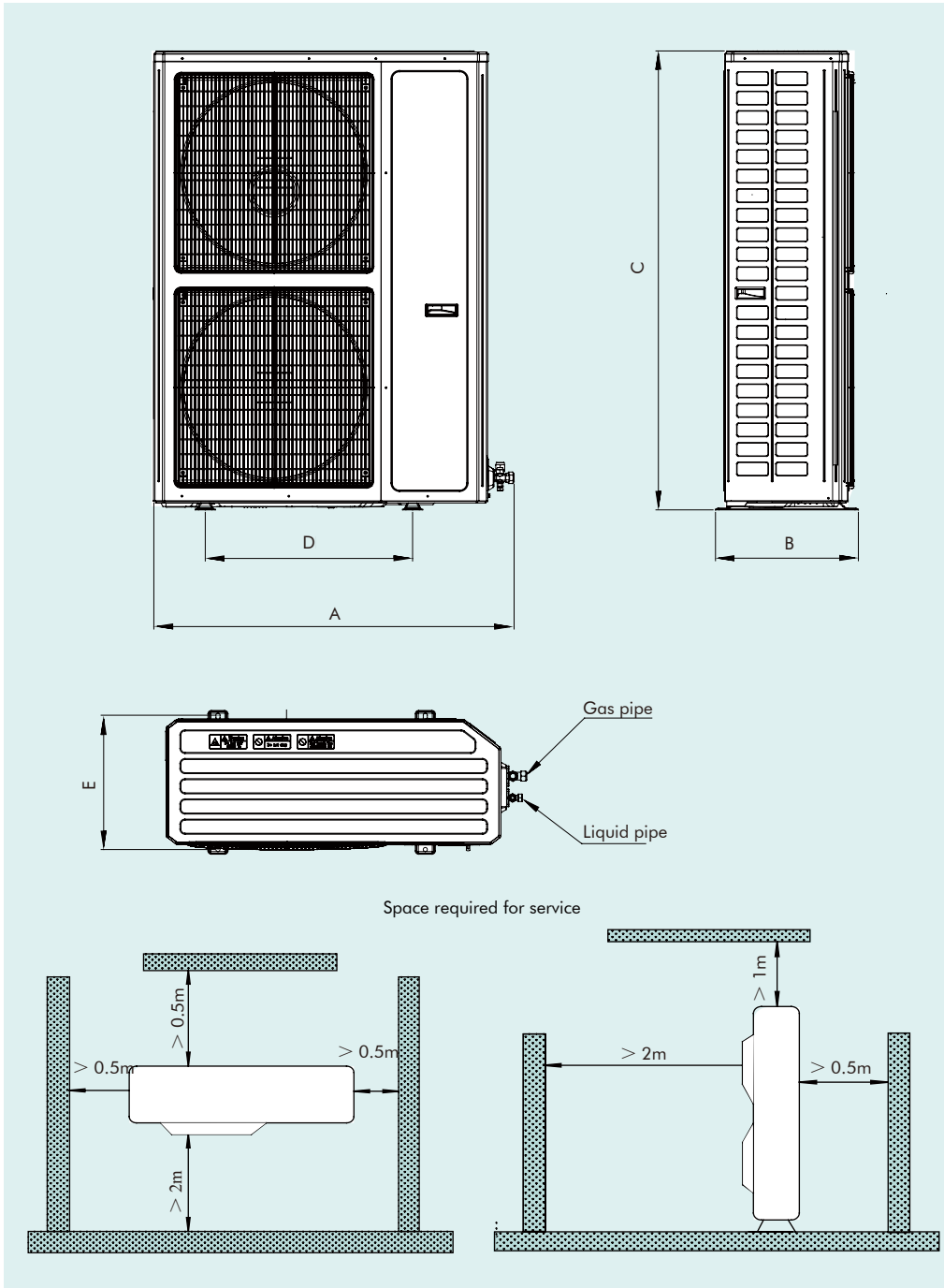

Unit: mm

Model \ Item	A	B	C	D	E
GUHD09NK3FO GUHD12NK3FO	848	320	540	540	286
GUHD18NK3FO	955	396	700	560	360
GUHD24NK3FO GUHD30NK3FO	980	427	790	610	395
GUHD36NK3FO GUHD36NM3FO	1107	440	1100	631	400
GUHD42NK3FO GUHD42NM3FO GUHD48NK3FO GUHD48NM3FO	958	412	1349	572	376
GUHD60NM3FO	1085	427	1365	620	395



6.3 Dimension – Controller

Wired Controller (Standard)

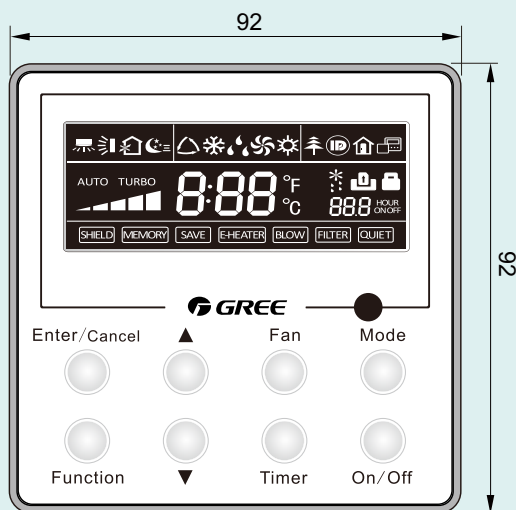

Centralized Controller

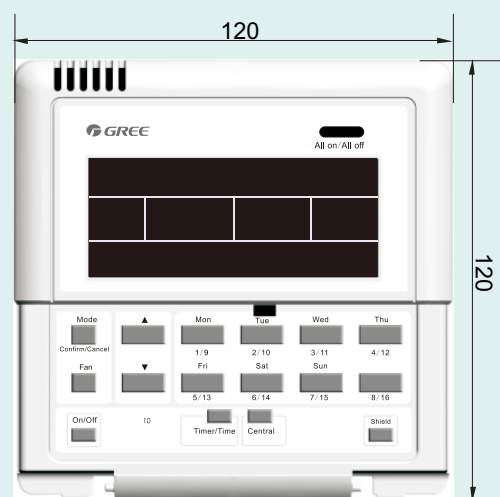

7 WIRING DIAGRAM

7.1 Field Wiring Diagrams

◆ Single-phase units (09K~30K)

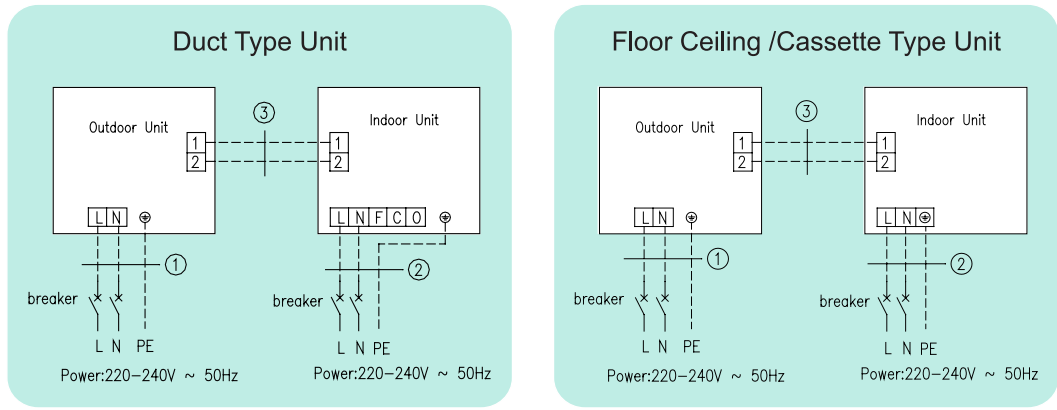

Outdoor Unit Model	Indoor Unit Model
GUHD09NK3FO	+GFH09K3FI
	+GTH09K3FI
GUHD12NK3FO	+GFH12K3FI
	+GTH12K3FI
	+GKH12K3FI
GUHD18NK3FO	+GFH18K3FI
	+GTH18K3FI
	+GKH18K3FI

① . Power cord 3×1.5 mm²(H07RN-F)
 ② . Power cord 3×1.0 mm²(H05VV-F)
 ③ . Communication Cords 2×0.75 mm²(H05VV-F)

Outdoor Unit Model	Indoor Unit Model
GUHD24NK3FO	+GFH24K3FI
	+GTH24K3FI
	+GKH24K3FI
GUHD30NK3FO	+GFH30K3FI
	+GTH30K3FI
	+GKH30K3FI

① . Power cord 3×2.5 mm²(H07RN-F)
 ② . Power cord 3×1.0 mm²(H05VV-F)
 ③ . Communication Cords 2×0.75 mm²(H05VV-F)

◆ Single-phase units (36K~48K):

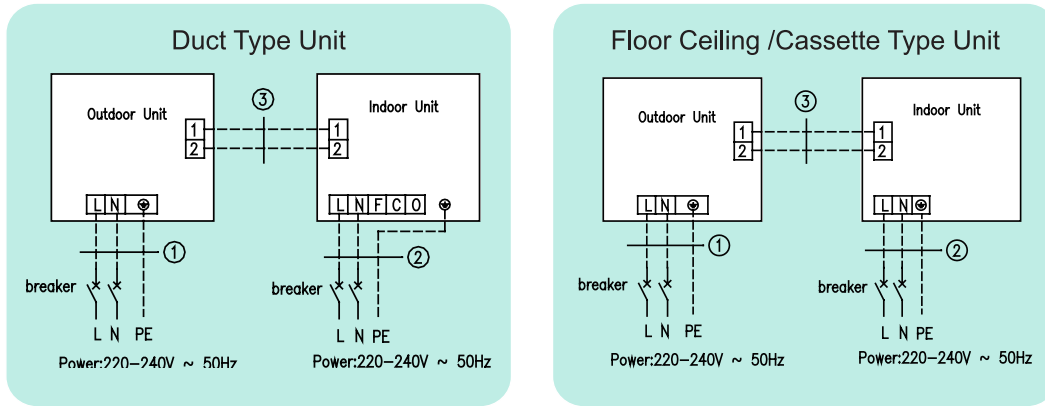

Outdoor Unit Model	Indoor Unit Model
GUHD36NK3FO	+GFH36K3FI
	+GTH36K3FI
	+GKH36K3FI
GUHD42NK3FO	+GFH42K3FI
	+GTH42K3FI
	+GKH42K3FI

① . Power cord $3 \times 2.5 \text{ mm}^2$ (H07RN-F)
 ② . Power cord $3 \times 1.0 \text{ mm}^2$ (H05VV-F)
 ③ . Communication Cords $2 \times 0.75 \text{ mm}^2$ (H05VV-F)

Outdoor Unit Model	Indoor Unit Model
GUHD48NK3FO	+GFH48K3FI
	+GTH48K3FI
	+GKH48K3FI

① . Power cord $3 \times 6.0 \text{ mm}^2$ (H07RN-F)
 ② . Power cord $3 \times 1.0 \text{ mm}^2$ (H05VV-F)
 ③ . Communication Cords $2 \times 0.75 \text{ mm}^2$ (H05VV-F)

◆ Three-phase units:

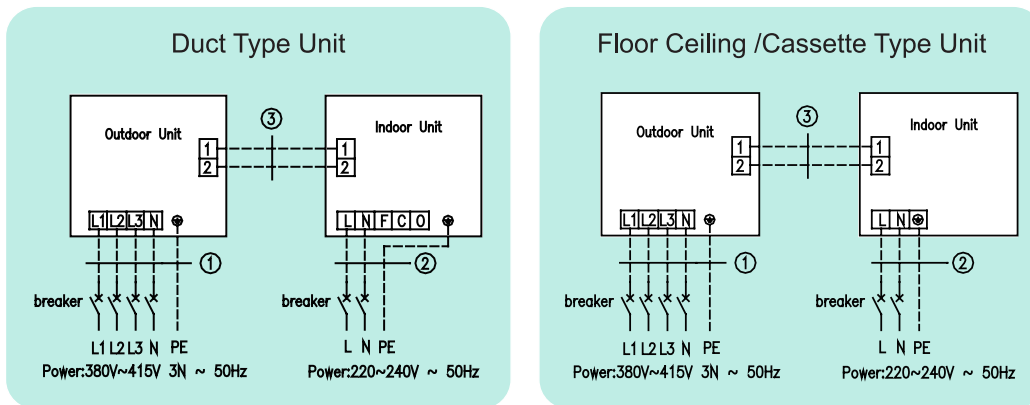

Outdoor Unit Model	Indoor Unit Model
GUHD36NM3FO	+GFH36K3FI
	+GTH36K3FI
	+GKH36K3FI
GUHD42NM3FO	+GFH42K3FI
	+GTH42K3FI
	+GKH42K3FI
GUHD48NM3FO	+GFH48K3FI
	+GTH48K3FI
	+GKH48K3FI
GUHD60NM3FO	+GFH60K3FI
	+GTH60K3FI
	+GKH60K3FI

① . Power cord 5×1.5 mm²(H07RN-F)
 ② . Power cord 3×1.0 mm²(H05VV-F)
 ③ . Communication Cords 2×0.75 mm²(H05VV-F)



7.2 Specification of Power Supply Wire and Air Switch

7.2.1 Outdoor Unit

Model	Power Supply (V,Ph,Hz)	Capability of Air Swith	Minimum Sectional Area of Earth Wire	Minimum Sectional Area of Power Supply Wire
		(A)	(mm ²)	(mm ²)
GUHD09NK3FO	220-240,1,50	13	1.5	1.5
GUHD12NK3FO	220-240,1,50	13	1.5	1.5
GUHD18NK3FO	220-240,1,50	16	1.5	1.5
GUHD24NK3FO	220-240,1,50	20	2.5	2.5
GUHD30NK3FO	220-240,1,50	20	2.5	2.5
GUHD36NK3FO	220-240,1,50	25	2.5	2.5
GUHD42NK3FO	220-240,1,50	25	2.5	2.5
GUHD48NK3FO	220-240,1,50	40	6.0	6.0
GUHD36NM3FO	380-415,3,50	16	1.5	1.5
GUHD42NM3FO	380-415,3,50	16	1.5	1.5
GUHD48NM3FO	380-415,3,50	16	1.5	1.5
GUHD60NM3FO	380-415,3,50	16	1.5	1.5

7.2.2 Indoor Unit

Duct Type

Model	Power Supply (V,Ph,Hz)	Capability of Air Swith	Minimum Sectional Area of Earth Wire	Minimum Sectional Area of Power Supply Wire
		(A)	(mm ²)	(mm ²)
GFH09K3FI	220-240,1,50	6	1.0	1.0
GFH12K3FI	220-240,1,50	6	1.0	1.0
GFH18K3FI	220-240,1,50	6	1.0	1.0
GFH24K3FI	220-240,1,50	6	1.0	1.0
GFH30K3FI	220-240,1,50	6	1.0	1.0
GFH36K3FI	220-240,1,50	6	1.0	1.0
GFH42K3FI	220-240,1,50	6	1.0	1.0
GFH48K3FI	220-240,1,50	6	1.0	1.0
GFH60K3FI	220-240,1,50	6	1.0	1.0

Ceiling Type

Model	Power Supply (V,Ph,Hz)	Capability of Air Swith	Minimum Sectional Area of Earth Wire	Minimum Sectional Area of Power Supply Wire
		(A)	(mm ²)	(mm ²)
GTH09K3FI	220-240,1,50	6	1.0	1.0
GTH12K3FI	220-240,1,50	6	1.0	1.0
GTH18K3FI	220-240,1,50	6	1.0	1.0
GTH24K3FI	220-240,1,50	6	1.0	1.0
GTH30K3FI	220-240,1,50	6	1.0	1.0
GTH36K3FI	220-240,1,50	6	1.0	1.0
GTH42K3FI	220-240,1,50	6	1.0	1.0
GTH48K3FI	220-240,1,50	6	1.0	1.0
GTH60K3FI	220-240,1,50	6	1.0	1.0

Cassette Type

Model	Power Supply (V,Ph,Hz)	Capability of Air Swith	Minimum Sectional Area of Earth Wire	Minimum Sectional Area of Power Supply Wire
		(A)	(mm ²)	(mm ²)
GKH12K3FI	220-240,1,50	6	1.0	1.0
GKH18K3FI	220-240,1,50	6	1.0	1.0
GKH24K3FI	220-240,1,50	6	1.0	1.0
GKH30K3FI	220-240,1,50	6	1.0	1.0
GKH36K3FI	220-240,1,50	6	1.0	1.0
GKH42K3FI	220-240,1,50	6	1.0	1.0
GKH48K3FI	220-240,1,50	6	1.0	1.0
GKH60K3FI	220-240,1,50	6	1.0	1.0

8 ACCESSORIES

7.1 Indoor Unit

Class Model Name	Wireless controller	wired controller	Central controller with weekly timer	Long-distance monitoring system	Communication cable	Water pump	Flexible pipe
GFH09K3FI GFH12K3FI GFH18K3FI GFH24K3FI GFH30K3FI GFH36K3FI GFH42K3FI GFH48K3FI GFH60K3FI	○	●	○	○	○	○	●
GTH09K3FI GTH12K3FI GTH18K3FI GTH24K3FI GTH30K3FI GTH36K3FI GTH42K3FI GTH48K3FI GTH60K3FI	●	○	○	○	○	/	●
GKH12K3FI GKH18K3FI GKH24K3FI GKH30K3FI GKH36K3FI GKH42K3FI GKH48K3FI GKH60K3FI	●	○	○	○	○	●	●

Note: "●" is standard part ; "○" is optional; "/" is unavailable.

Gree Electric Appliance, Inc. of Zhuhai, founded in 1991, is the world's largest air conditioner enterprise integrating R&D, manufacturing, marketing and services. Technology Innovation and quality are always our priority. With efforts of thousands of Gree's engineers, we own more than 3500 patents for our products. Nowadays, we have 7 production bases in Zhuhai, Chongqing, Hefei and Zhengzhou(China), as well as Brazil, Pakistan and Vietnam, with annual production capacity of 30 million sets of residential air conditioners and 4 million sets of commercial air conditioners.

With the installation of Gree commercial air conditioners in important projects at home and abroad like Media Village for 2008 Beijing Olympic Games, Stadiums for 2010 World Cup in South Africa, as well as India Telecom base station, Gree commercial air conditioners are ready to develop steadily to every corner in the world, to present a more comfortable and harmonious working environment and family atmosphere.



Add: West Jinji Rd, Qianshan Zhuhai, Guangdong, China 519070

Tel: (+86-756)8614883 Fax: (+86-756)8614998

Http://www.gree.com Email: gree@gree.com.cn

For continuous improvement in the products, Gree reserves the right to modify the product specification and appearance in this manual without notice and without incurring and obligations.

■ SJ00394493