

Service Manual

Model: GWHD(18)NK3FO
GWHD(24)NK3FO
GWHD(24)NK3GO
GWHD(28)NK3FO
GWHD(36)NK3BO
GWHD(42)NK3AO
(Refrigerant:R410A)

Table of Contents

Part I : Technical Information	1
1. Summary	1
2. Specifications	2
3. Outline Dimension Diagram	10
4. Refrigerant System Diagram	12
5. Electrical Part	14
5.1 Wiring Diagram.....	14
5.2 PCB Printed Diagram	19
6. Function and Control	23
Part II : Installation and Maintenance	28
7. Notes for Installation and Maintenance	28
8. Installation Manual	30
8.1 Electrical Connections.....	31
8.2 Installing the Outdoor Unit.....	34
8.3 Installation Dimension Diagram.....	35
8.4 Check after Installation.....	36
9. Maintenance	46
9.1 Precautions before Performing Inspection or Repair	46
9.2 Flashing LED of Indoor/Outdoor Unit and Primary Judgement	47
9.3 Malfunction Checking and Elimination	48
9.4 Maintenance Method for Normal Malfunction.....	72
10. Exploded View and Parts' List	74
11. Removal Procedure	85
Appendix:	105
Appendix 1: Reference Sheet of Celsius and Fahrenheit	105
Appendix 2: Configuration of Connection Pipe.....	105
Appendix 3: Pipe Expanding Method	106
Appendix 4: List of Resistance for Ambient Temperature Sensor	107



Part I : Technical Information

1. Summary

Outdoor Unit

GWHD(18)NK3FO

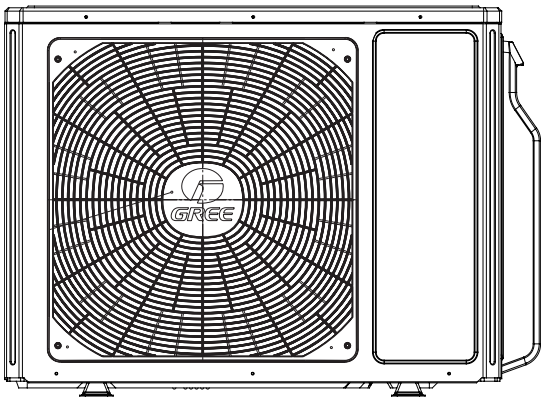

GWHD(24)NK3FO
GWHD(24)NK3GO
GWHD(28)NK3FO

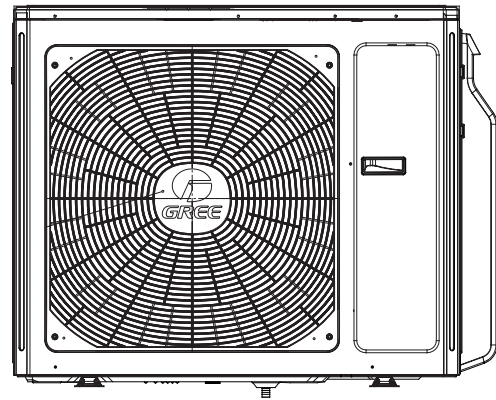

GWHD(36)NK3BO

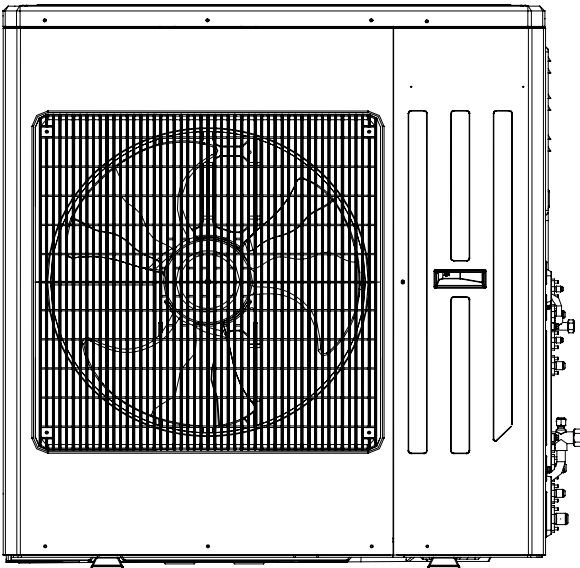

GWHD(42)NK3AO

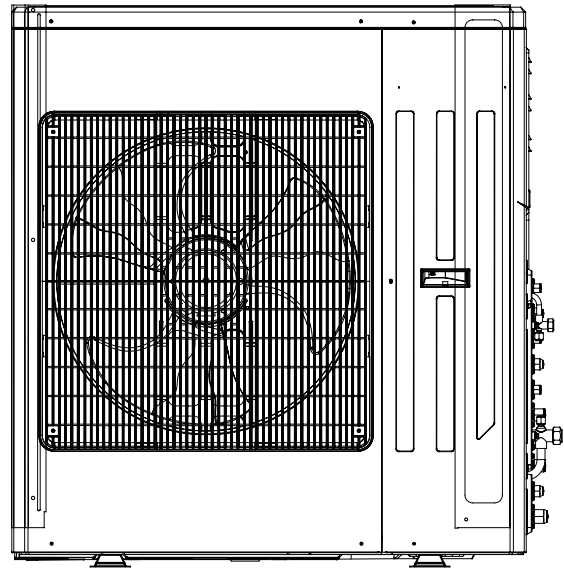

2. Specifications

Model			GWHD(18)NK3FO	
Product Code			CB228W03500/CB228W03501	
Power supply	Rated Voltage	V~	220-240V	
	Rated Frequency	Hz	50	
	Phases		1	
Cooling capacity(max~min)		W	5000(2050~6200)	
Heating capacity(max~min)		W	5600(2500~6650)	
Cooling Power Input(max~min)		W	1550(500~2550)	
Heating Power Input(max~min)		W	1550(580~2700)	
Cooling Current Input		A	6.88	
Heating Current Input		A	6.88	
Rated Power Input		W	2700	
Rated Current		A	11.98	
SEER		W/W	5.6	
SCOP		W/W	3.8	
Outdoor Unit	Compressor Trademark		ZHUHAI LANDA COMPRESSOR CO.,LTD	
	Compressor Model		QXA-B141zF030A	
	Compressor Refrigerant Oil Type		RB68EP	
	Compressor Type		Rotary	
	L.R.A		A	/
	Compressor Rated Load Amp (RLA)		A	7.2
	Compressor Power Input		W	1440
	Compressor Thermal Protector			1NT11L-6233
	Throttling Method			Electron expansion valve
	Cooling Operation Ambient Temperature Range		°C	-15~48
	Heating Operation Ambient Temperature Range		°C	-15~24
	Condenser Material			Aluminum Fin-copper Tube
	Condenser Pipe Diameter		mm	Φ7
	Rows-Fin Gap(mm)		mm	2-1.4
	Coil length (l) X height (H) X coil width (L)		mm	851X38.1X660
	Fan Motor Speed (rpm) (H/M/L)		rpm	630
	Output of Fan Motor		W	60
	Fan Motor RLA		A	/
	Fan Motor Capacitor		μF	/
	Air Flow Volume of Outdoor Unit		m ³ /h	3200
	Fan Type-Piece			Axial-flow
	Fan Diameter		mm	Φ520
	Defrosting Method			Automatic Defrosting
	Climate Type			T1
	Isolation			I
	Moisture Protection			IP24
	Permissible Excessive Operating Pressure for the Discharge Side		MPa	4.3
	Permissible Excessive Operating Pressure for the Suction Side		MPa	2.5
	Dimension (W/H/D)		mm	963X700X396
	Dimension of Package (L/W/H)		mm	1026X455X735
	Dimension of Package(L/W/H)		mm	1029X458X750
	Net Weight		kg	50
	Gross Weight		kg	55
Refrigerant Charge			R410A	
Refrigerant Charge		kg	1.40	

Outdoor Unit	Cross-sectional Area of Power Cable Conductor	mm ²	2.50
	Recommended Power Cable(Core)	N	3
	Connection Pipe Connection Method	-	Flare Connection
	Not Additional Gas Connection Pipe Length	m	5
	Connection Pipe Gas Additional Charge	g/m	15
	Outer Diameter of Liquid Pipe(GREE Allocation) (Metric)	mm	Φ6
	Outer Diameter of Gas Pipe(GREE Allocation) (Metric)	mm	Φ9.52
	Connection Pipe Max. Height Distance(indoor and indoor)	m	10
	Max. equivalent connection pipe length(outdoor to last indoor)	m	20
	Connection Pipe Max. Length Distance(total length)	m	20

The above data is subject to change without notice; please refer to the nameplate of the unit.

Model			GWHD(24)NK3FO	GWHD(24)NK3GO
Product Code			CB228W03301	CB228W03401
Power supply	Rated Voltage	V~	220-240V	220-240V
	Rated Frequency	Hz	50	50
	Phases		1	1
Cooling capacity(max~min)		W	7000(2200~10000)	7100(2200~10000)
Heating capacity(max~min)		W	7700(2600~11000)	8500(3600~11000)
Cooling Power Input(max~min)		W	2460(650~4550)	2400(650~4550)
Heating Power Input(max~min)		W	2560(980~3950)	2350(980~3950)
Cooling Current Input		A	10.91	10.91
Heating Current Input		A	11.36	11.36
Rated Power Input		W	4550	4550
Rated Current		A	20.19	20.19
SEER		W/W	5.1	5.1
SCOP		W/W	3.8	3.8
Outdoor Unit	Compressor Trademark		ZHUHAI LANDA COMPRESSOR CO.,LTD	ZHUHAI LANDA COMPRESSOR CO.,LTD
	Compressor Model		QXAS-D23zX090B	QXAS-D23zX090B
	Compressor Refrigerant Oil Type		RB68EP	RB68EP
	Compressor Type		Rotary	Rotary
	L.R.A		A	/
	Compressor Rated Load Amp (RLA)		A	11.5
	Compressor Power Input		W	2550
	Compressor Thermal Protector			1NT11L-6233
	Throttling Method			Electron expansion valve
	Cooling Operation Ambient Temperature Range		°C	-15~48
	Heating Operation Ambient Temperature Range		°C	-15~24
	Condenser Material			Aluminum Fin-copper Tube
	Condenser Pipe Diameter		mm	Φ7
	Rows-Fin Gap(mm)		mm	2-1.4
	Coil length (l) X height (H) X coil width (L)		mm	982.2X38.1X748
	Fan Motor Speed (rpm) (H/M/L)		rpm	710
	Output of Fan Motor		W	90
	Fan Motor RLA		A	/
	Fan Motor Capacitor		μF	/
	Air Flow Volume of Outdoor Unit		m ³ /h	4000
	Fan Type-Piece			Axial-flow
	Fan Diameter		mm	Φ552
	Defrosting Method			Automatic Defrosting
	Climate Type			T1
	Isolation			I
	Moisture Protection			IP24
	Permissible Excessive Operating Pressure for the Discharge Side		MPa	4.3
Permissible Excessive Operating Pressure for the Suction Side		MPa	2.5	
Dimension (W/H/D)		mm	1001X790X427	
Dimension of Package (L/W/H)		mm	1080X485X840	
Dimension of Package(L/W/H)		mm	1083X488X855	
Net Weight		kg	68	
Gross Weight		kg	73	
Refrigerant Charge			R410A	
Refrigerant Charge		kg	2.00	

Outdoor Unit	Cross-sectional Area of Power Cable Conductor	mm ²	2.50	2.50
	Recommended Power Cable(Core)	N	3	3
	Connection Pipe Connection Method	-	Flare Connection	Flare Connection
	Not Additional Gas Connection Pipe Length	m	5	5
	Connection Pipe Gas Additional Charge	g/m	15	15
	Outer Diameter of Liquid Pipe(GREE Allocation) (Metric)	mm	Φ6	Φ6
	Outer Diameter of Gas Pipe(GREE Allocation) (Metric)	mm	Φ9.52	Φ9.52
	Connection Pipe Max. Height Distance(indoor and indoor)	m	10	10
	Max. equivalent connection pipe length(outdoor to last indoor)	m	20	20
	Connection Pipe Max. Length Distance(total length)	m	20	20

The above data is subject to change without notice. Please refer to the nameplate of the unit.

Model			GWHD(28)NK3FO	
Product Code			CB228W03600/CB228W03601	
Power supply	Rated Voltage	V~	220-240V	
	Rated Frequency	Hz	50	
	Phases		1	
Cooling capacity(max~min)		W	8000(2200~10000)	
Heating capacity(max~min)		W	9300(2800~11000)	
Cooling Power Input(max~min)		W	2490(650~4550)	
Heating Power Input(max~min)		W	2580(980~3950)	
Cooling Current Input		A	11.05	
Heating Current Input		A	11.45	
Rated Power Input		W	4550	
Rated Current		A	20.19	
SEER		W/W	5.1	
SCOP		W/W	3.8	
Outdoor Unit	Compressor Trademark		ZHUHAI LANDA COMPRESSOR CO.,LTD	
	Compressor Model		QXAS-D23zX090B	
	Compressor Refrigerant Oil Type		RB68EP	
	Compressor Type		Rotary	
	L.R.A		A	/
	Compressor Rated Load Amp (RLA)		A	11.5
	Compressor Power Input		W	2550
	Compressor Thermal Protector			1NT11L-6233
	Throttling Method			Electron expansion valve
	Cooling Operation Ambient Temperature Range		°C	-15~48
	Heating Operation Ambient Temperature Range		°C	-15~24
	Condenser Material			Aluminum Fin-copper Tube
	Condenser Pipe Diameter		mm	Φ7
	Rows-Fin Gap(mm)		mm	2-1.4
	Coil length (l) X height (H) X coil width (L)		mm	982.2X38.1X748
	Fan Motor Speed (rpm) (H/M/L)		rpm	710
	Output of Fan Motor		W	90
	Fan Motor RLA		A	/
	Fan Motor Capacitor		μF	/
	Air Flow Volume of Outdoor Unit		m ³ /h	4000
	Fan Type-Piece			Axial-flow
	Fan Diameter		mm	Φ552
	Defrosting Method			Automatic Defrosting
	Climate Type			T1
	Isolation			I
	Moisture Protection			IP24
	Permissible Excessive Operating Pressure for the Discharge Side		MPa	4.3
	Permissible Excessive Operating Pressure for the Suction Side		MPa	2.5
	Dimension (W/H/D)		mm	1001X790X427
	Dimension of Package (L/W/H)		mm	1080X485X840
Dimension of Package(L/W/H)		mm	1083X488X855	
Net Weight		kg	69	
Gross Weight		kg	74	
Refrigerant Charge			R410A	
Refrigerant Charge		kg	2.20	

Outdoor Unit	Cross-sectional Area of Power Cable Conductor	mm ²	2.50
	Recommended Power Cable(Core)	N	3
	Connection Pipe Connection Method	-	Flare Connection
	Not Additional Gas Connection Pipe Length	m	5
	Connection Pipe Gas Additional Charge	g/m	15
	Outer Diameter of Liquid Pipe(GREE Allocation) (Metric)	mm	Φ6
	Outer Diameter of Gas Pipe(GREE Allocation) (Metric)	mm	Φ9.52
	Connection Pipe Max. Height Distance(indoor and indoor)	m	10
	Max. equivalent connection pipe length(outdoor to last indoor)	m	20
	Connection Pipe Max. Length Distance(total length)	m	20

The above data is subject to change without notice. Please refer to the nameplate of the unit.

Model			GWHD(36)NK3BO	GWHD(42)NK3AO
Product Code			CN860W0130	CN860W0020
Power supply	Rated Voltage	V~	220-240V	220-240V
	Rated Frequency	Hz	50	50
	Phases		1	1
Cooling capacity(max~min)		W	10500(2100~11000)	12100(2100~13600)
Heating capacity(max~min)		W	12000(2600~13000)	13000(2600~14000)
Cooling Power Input		W	3500	3590
Heating Power Input		W	3750	3550
Cooling Current Input		A	15.42	16.43
Heating Current Input		A	15.20	16.22
Rated Power Input		W	4880	5300
Rated Current		A	21.65	23.50
SEER		W/W	5.5	/
SCOP		W/W	3.8	/
Outdoor Unit	Compressor Trademark		ZHUHAI LANDA COMPRESSOR CO.,LTD	MITSUBISHI ELECTRIC(GUANGZHOU) COMPRESSOR CO.LTD
	Compressor Model		QXAS-D32zX090A	TNB306FPGMC
	Compressor Refrigerant Oil Type		RB68ER	PVE(PV50S)
	Compressor Type		Inverter Rotary	Inverter Rotary
	L.R.A		A	/
	Compressor Rated Load Amp (RLA)		A	14
	Compressor Power Input		W	3300
	Compressor Thermal Protector			internal
	Throttling Method			Electron expansion valve
	Cooling Operation Ambient Temperature Range		°C	-15~48
	Heating Operation Ambient Temperature Range		°C	-15~27
	Condenser Material			Copper tube-Aluminum fin
	Condenser Pipe Diameter		mm	Φ7.94
	Rows-Fin Gap(mm)		mm	2-1.4
	Coil length (l) X height (H) X coil width (L)		mm	1009.4X38.1X1056
	Fan Motor Speed (rpm) (H/M/L)		rpm	820
	Output of Fan Motor		W	170
	Fan Motor RLA		A	/
	Fan Motor Capacitor		μF	/
	Air Flow Volume of Outdoor Unit		m ³ /h	5200
	Fan Type-Piece			Axial-flow
	Fan Diameter		mm	Φ570-152
	Defrosting Method			Automatic Defrosting
	Climate Type			T1
	Isolation			I
	Moisture Protection			IPX4
	Permissible Excessive Operating Pressure for the Discharge Side		MPa	4.3
	Permissible Excessive Operating Pressure for the Suction Side		MPa	2.5
	Dimension (W/H/D)		mm	1015X440X1103
	Dimension of Package (L/W/H)		mm	1155X490X1220
Dimension of Package(L/W/H)		mm	1158X493X1235	
Net Weight		kg	94	
Gross Weight		kg	104	
Refrigerant Charge			R410A	
Refrigerant Charge		kg	4.3	

Outdoor Unit	Cross-sectional Area of Power Cable Conductor	mm ²	4.0	4.0
	Recommended Power Cable(Core)	N	3	3
	Connection Pipe Connection Method	-	Flare Connection	Flare Connection
	Not Additional Gas Connection Pipe Length	m	40	50
	Connection Pipe Gas Additional Charge	g/m	22	22
	Outer Diameter of Liquid Pipe(GREE Allocation) (Metric)1	mm	Φ6	Φ6
	Outer Diameter of Gas Pipe(GREE Allocation) (Metric)1	mm	Φ9.52	Φ9.52
	Outer Diameter of Liquid Pipe(GREE Allocation) (Metric)2		Φ6	Φ6
	Outer Diameter of Gas Pipe(GREE Allocation) (Metric)2		Φ9.52	Φ9.52
	Outer Diameter of Liquid Pipe(GREE Allocation) (Metric)3		Φ6	Φ6
	Outer Diameter of Gas Pipe(GREE Allocation) (Metric)3		Φ12	Φ12
	Outer Diameter of Liquid Pipe(GREE Allocation) (Metric)4		Φ9.52	Φ6
	Outer Diameter of Gas Pipe(GREE Allocation) (Metric)4		Φ16	Φ12
	Outer Diameter of Liquid Pipe(GREE Allocation) (Metric)5		/	Φ9.52
	Outer Diameter of Gas Pipe(GREE Allocation) (Metric)5		/	Φ16
	Connection Pipe Max. Height Distance(indoor and indoor)	m	7.5	7.5
Max. equivalent connection pipe length(outdoor to last indoor)	m	20	25	
Connection Pipe Max. Length Distance(total length)	m	70	80	

The above data is subject to change without notice. Please refer to the nameplate of the unit.

3. Outline Dimension Diagram

(1) Model:GWHD(18)NK3FO

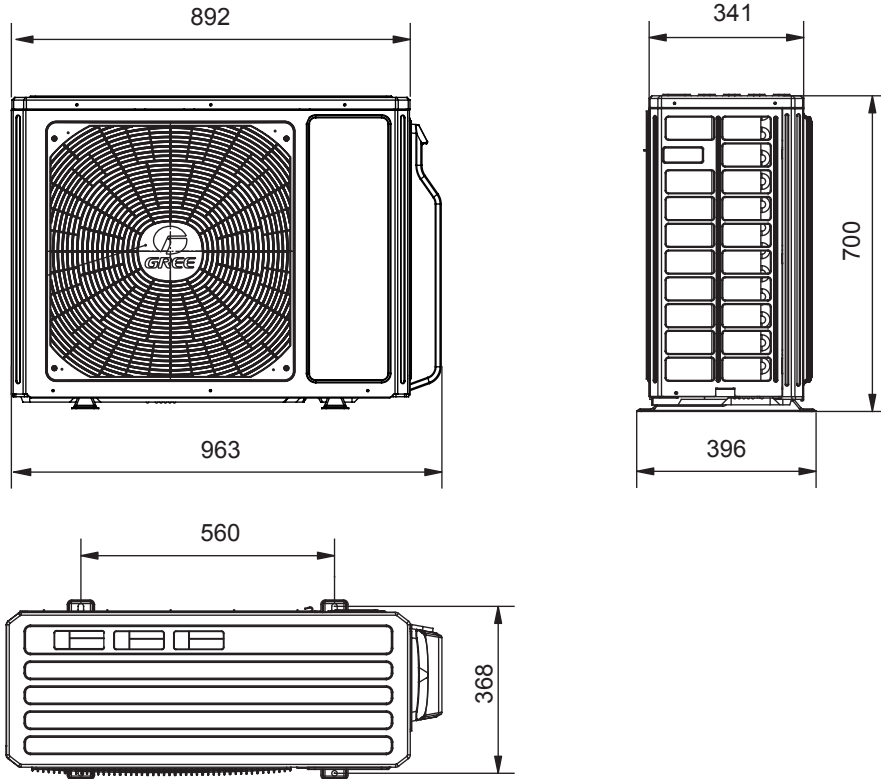

(2) Models:GWHD(24)NK3FO GWHD(24)NK3GO GWHD(28) NK3FO

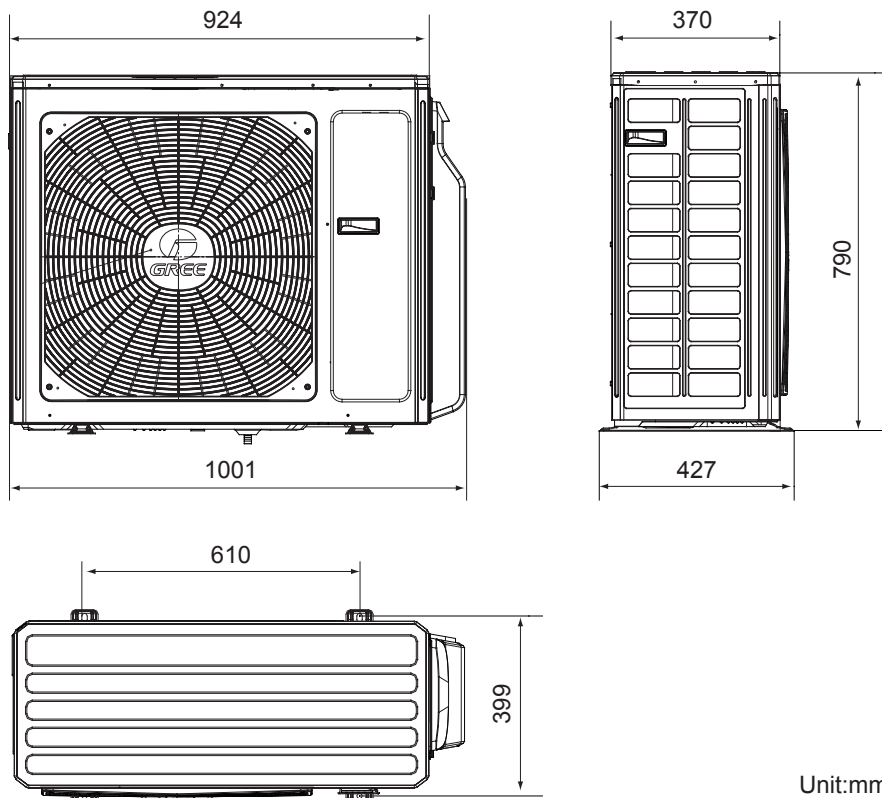

Unit:mm

(3) Model:GWHD(36)NK3BO

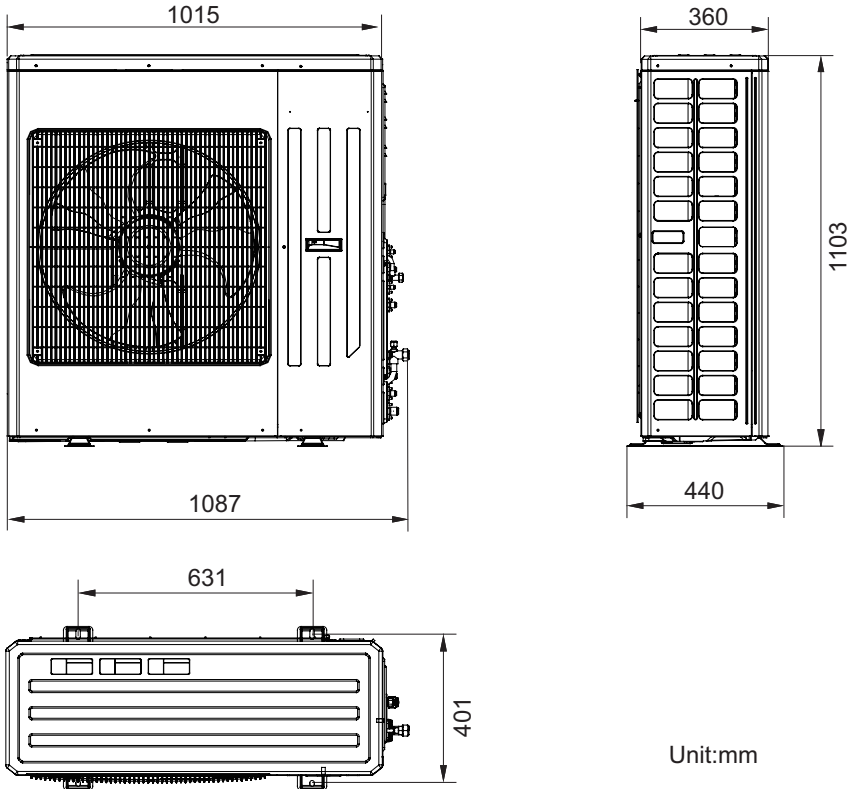

(4) Model:GWHD(42)NK3AO

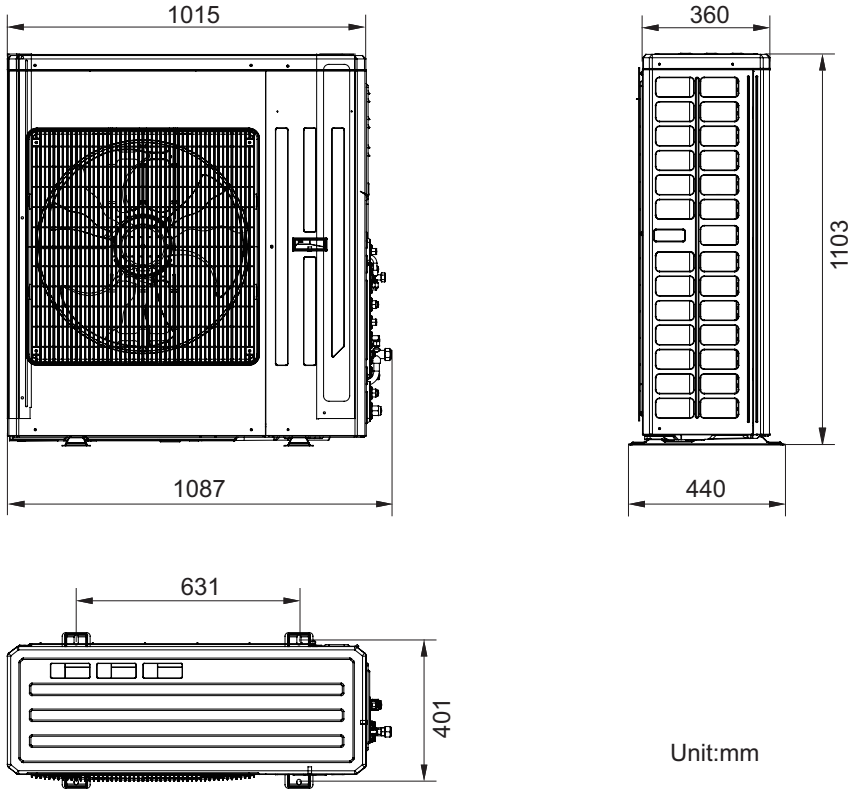

4. Refrigerant System Diagram

Models:GWHD(18)NK3FO GWHD(24)NK3FO GWHD(24)NK3GO GWHD(28) NK3FO

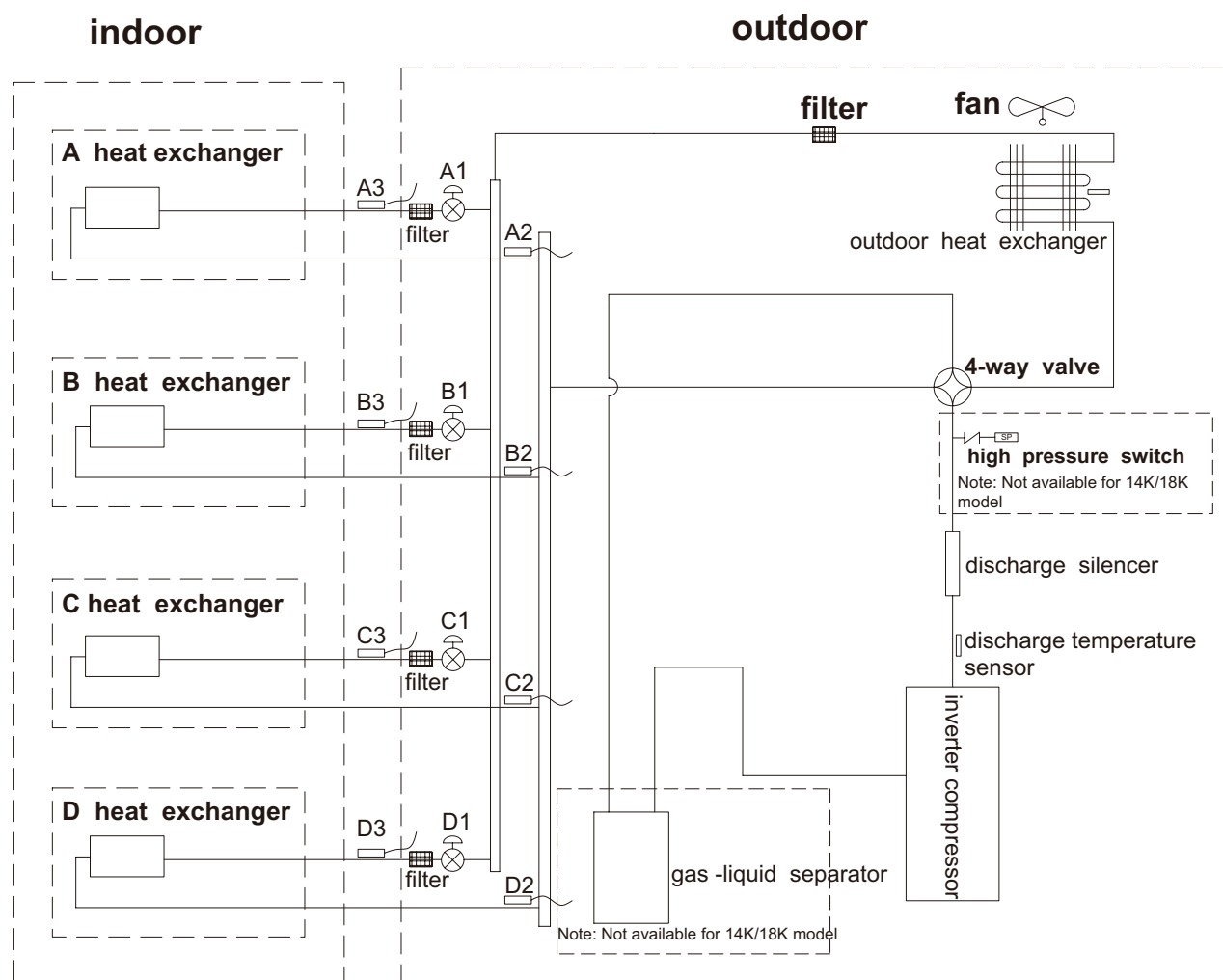

A1:A-unit electronic expansion valve B1:B-unit electronic expansion valve
C1:C-unit electronic expansion valve D1:D-unit electronic expansion valve
A2:A-unit gas pipe temperature sensor B2:B-unit gas pipe temperature sensor
C2:C-unit gas pipe temperature sensor D2:D-unit gas pipe temperature sensor
A3:A-unit liquid pipe temperature sensor B3:B-unit liquid pipe temperature sensor
C3:C-unit liquid pipe temperature sensor D3:D-unit liquid pipe temperature sensor

Models:GWHD(36)NK3BO,GWHD(42)NK3AO

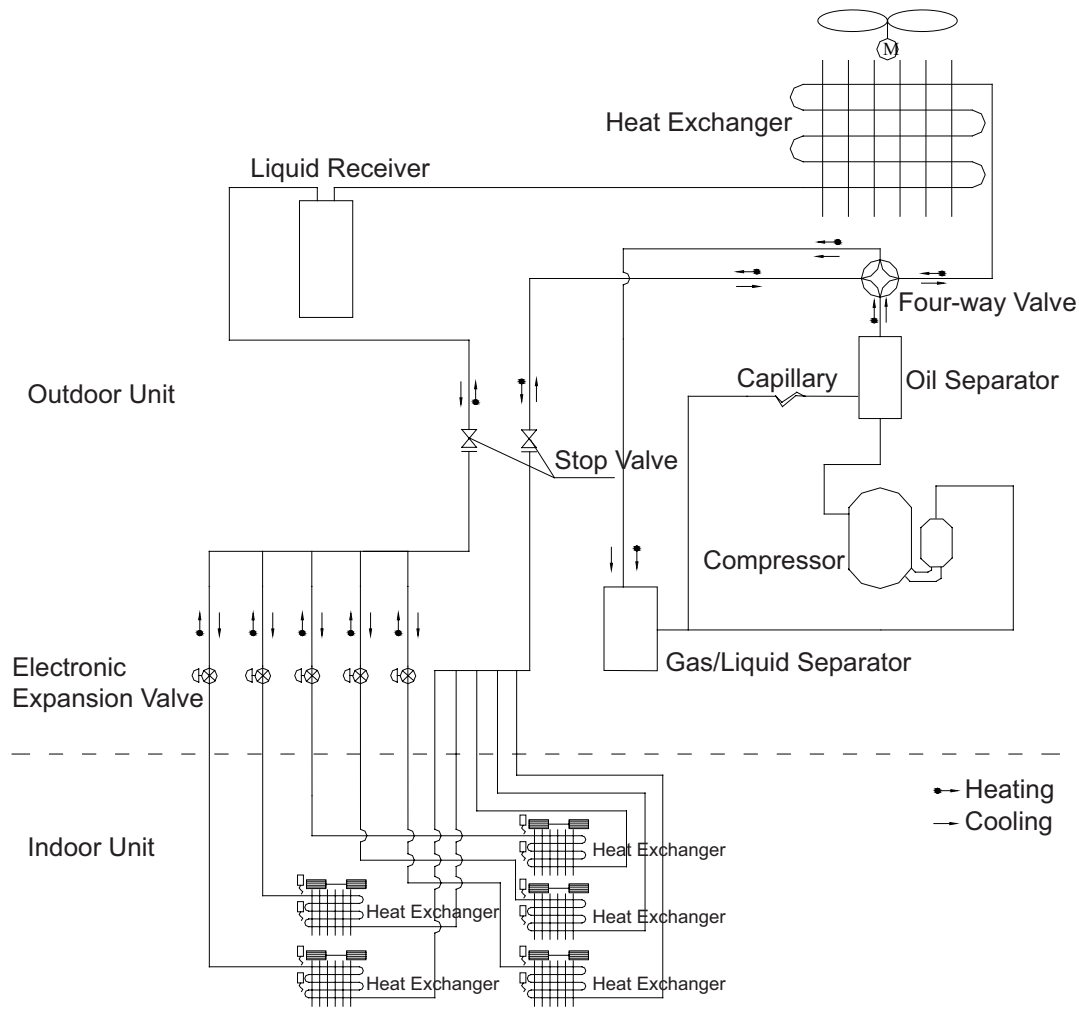

The outdoor and indoor units start to work once the power is switched on. During the cooling operation, the low temperature, low pressure refrigerant gas from the heat exchanger of each indoor unit gets together and then is taken into the compressor to be compressed into high temperature, high pressure gas, which will soon go to the heat exchanger of the outdoor unit to exchange heat with the outdoor air and then is turned into refrigerant liquid. After passing through the throttling device, the temperature and pressure of the refrigerant liquid will further decrease and then go the main valve. After that, it will be divided and go to the heat exchanger of each indoor unit to exchange heat with the air which needs to be conditioned. Consequently, the refrigerant liquid become low temperature, low pressure refrigerant gas again. Such a refrigeration cycle goes round and round to achieve the desired cooling purpose. During the heating operation, the four-way valve is involved to make the refrigeration cycle run reversely. The refrigerant radiates heat in the heat exchanger of the indoor unit (so do the electric heating devices) and absorb heat in the heat exchanger of the outdoor unit for a heat pump heating cycle so as to achieve the desired heating purpose.

5. Electrical Part

5.1 Wiring Diagram

● Instruction

Symbol	Symbol Color	Symbol	Symbol Color	Symbol	Name
WH	White	GN	GREEN	COMP	Compressor
YE	Yellow	BN	Brown		Grounding wire
RD	Red	BU	Blue		
YEGN	Yellow/Green	BK	Black		
VT	Violet	OG	Orange		

● Indoor Unit

(1)Model:GWHD(18)NK3FO(CB228W03501)

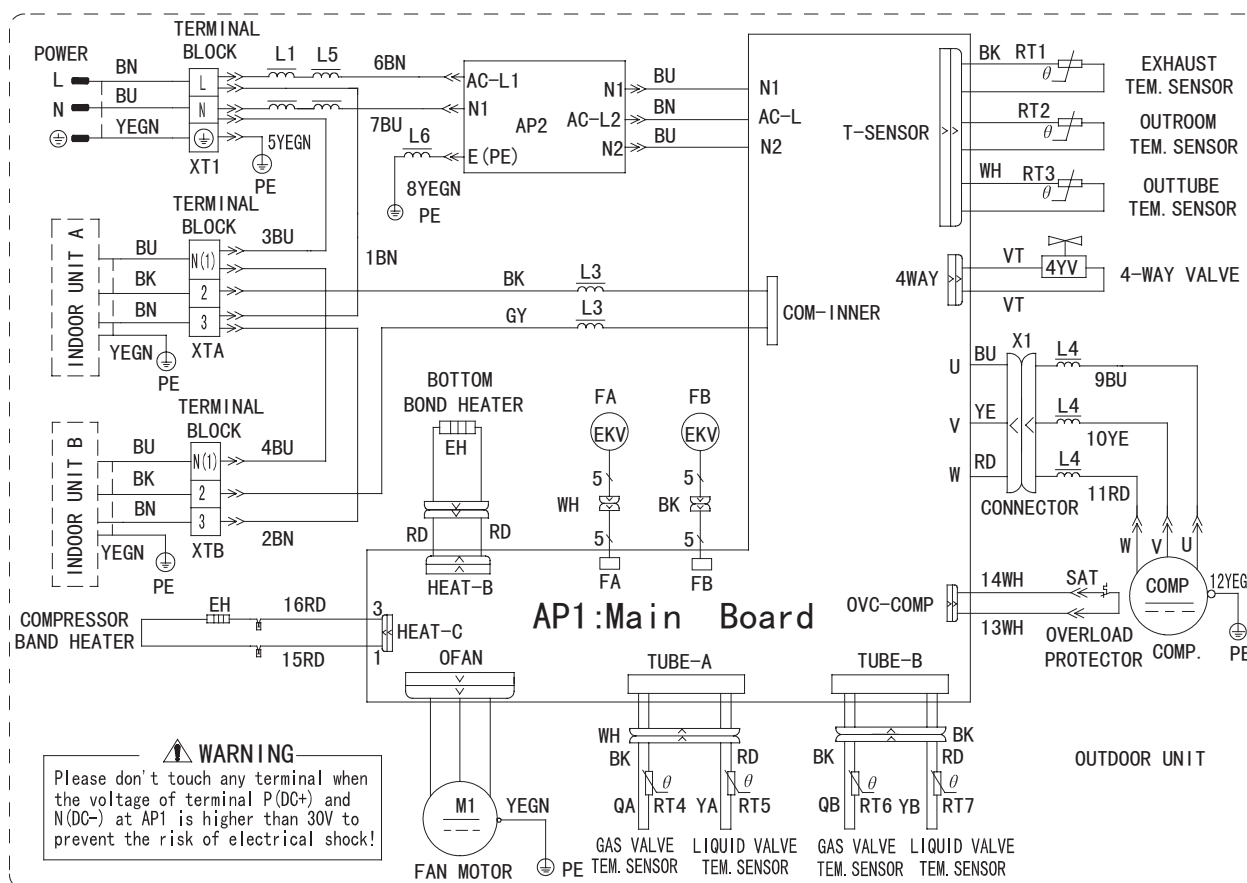

(2)Model:GWHD(18)NK3FO(CB228W0350)

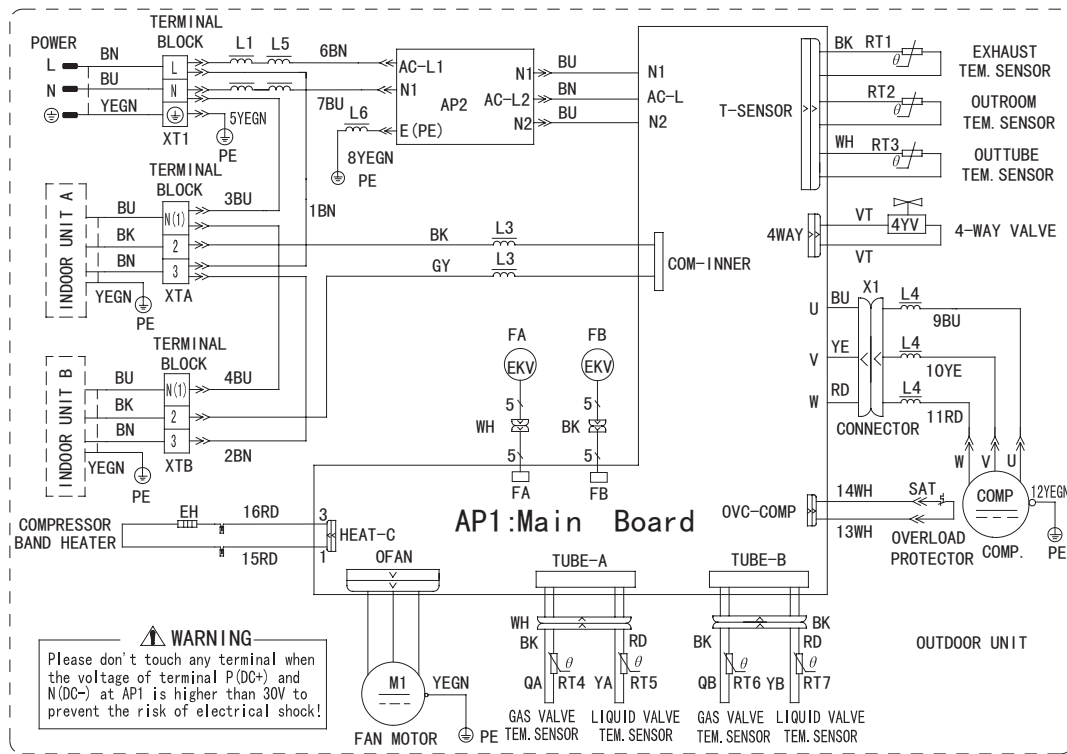

(3)Model:GWHD(24)NK3FO

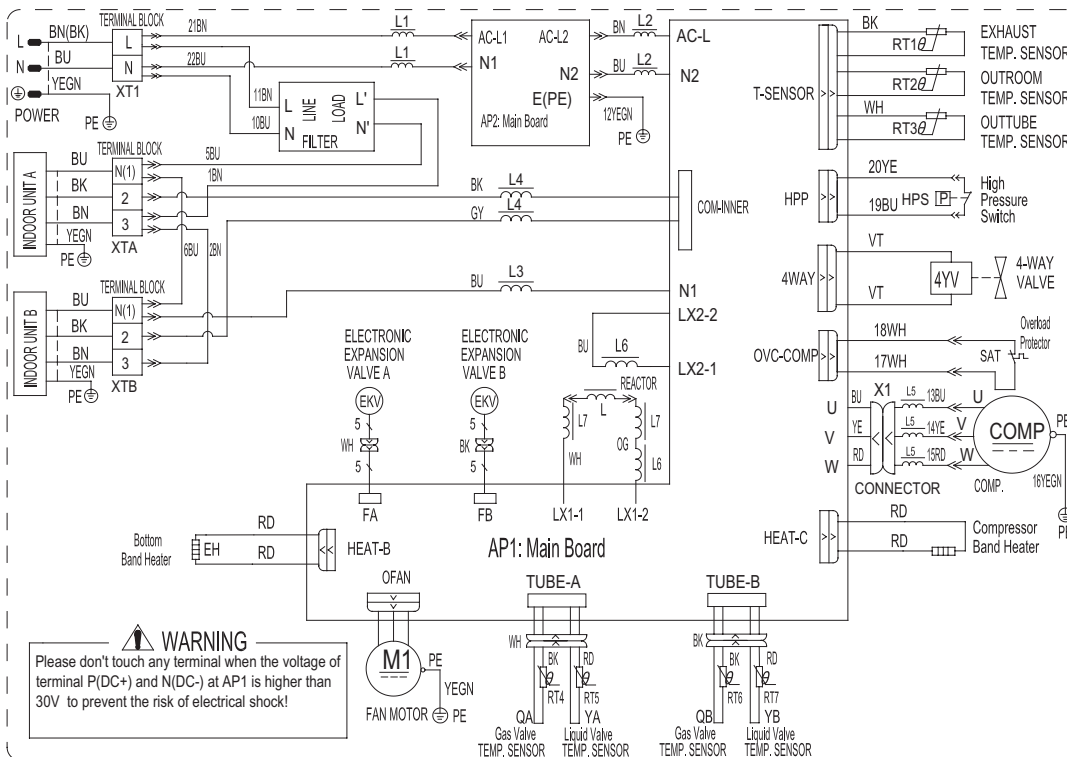

(4) Model: GWHD(24)NK3GO

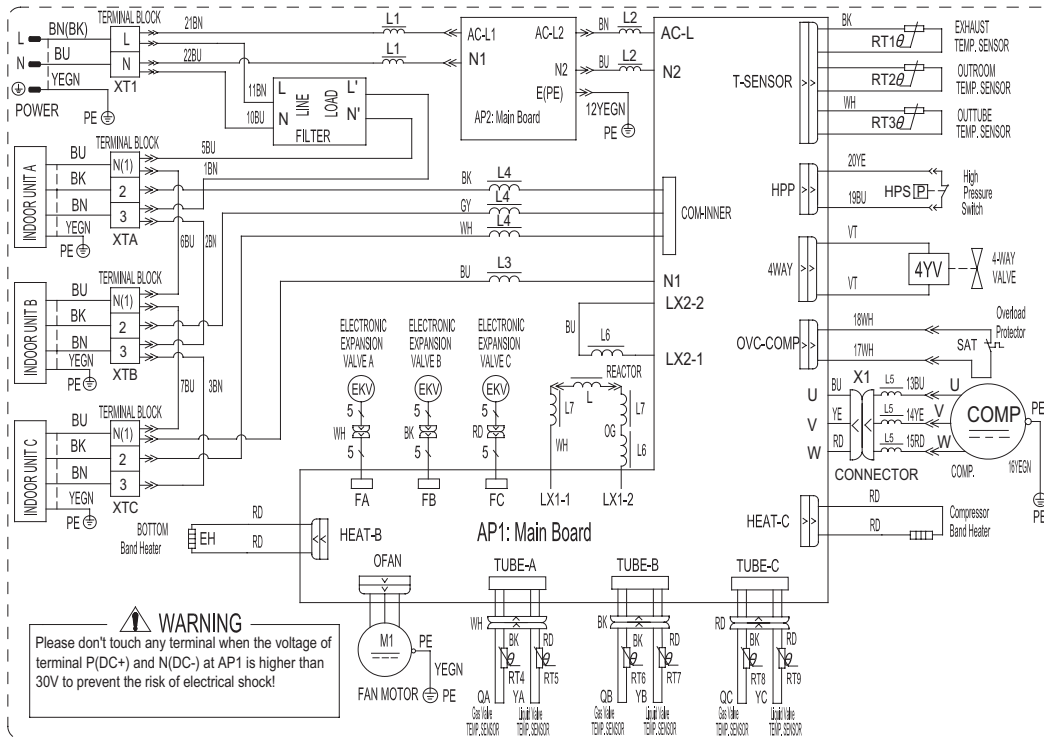

(5) Model: GWHD(28) NK3FO(CB228W03601)(CB228W03600)

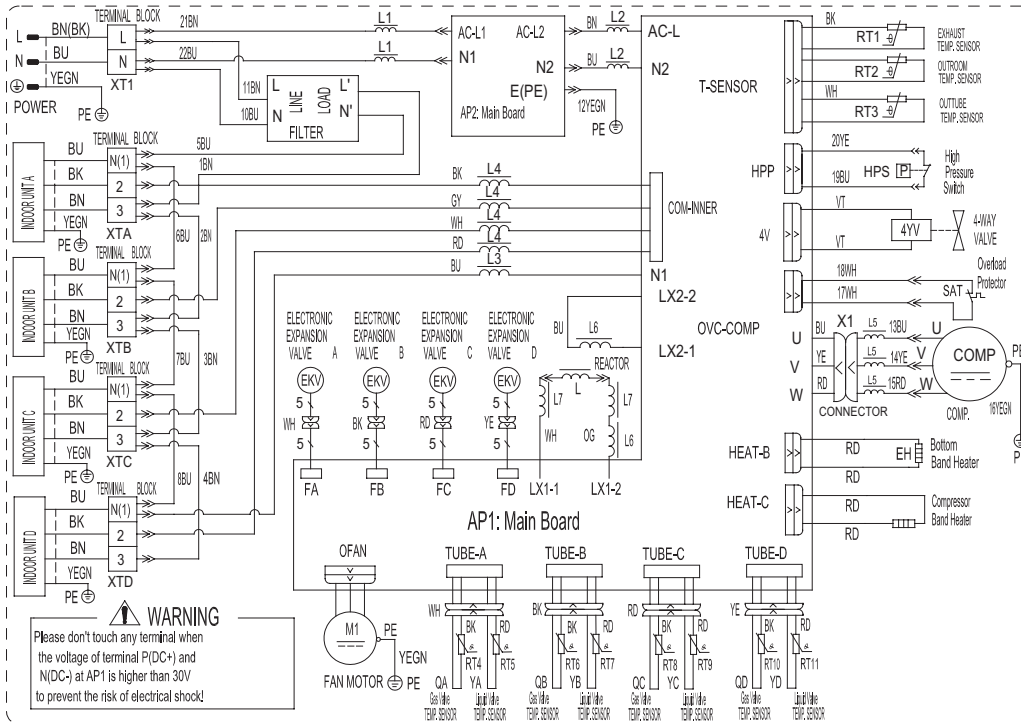

(6)Model:GWHD(36)NK3BO

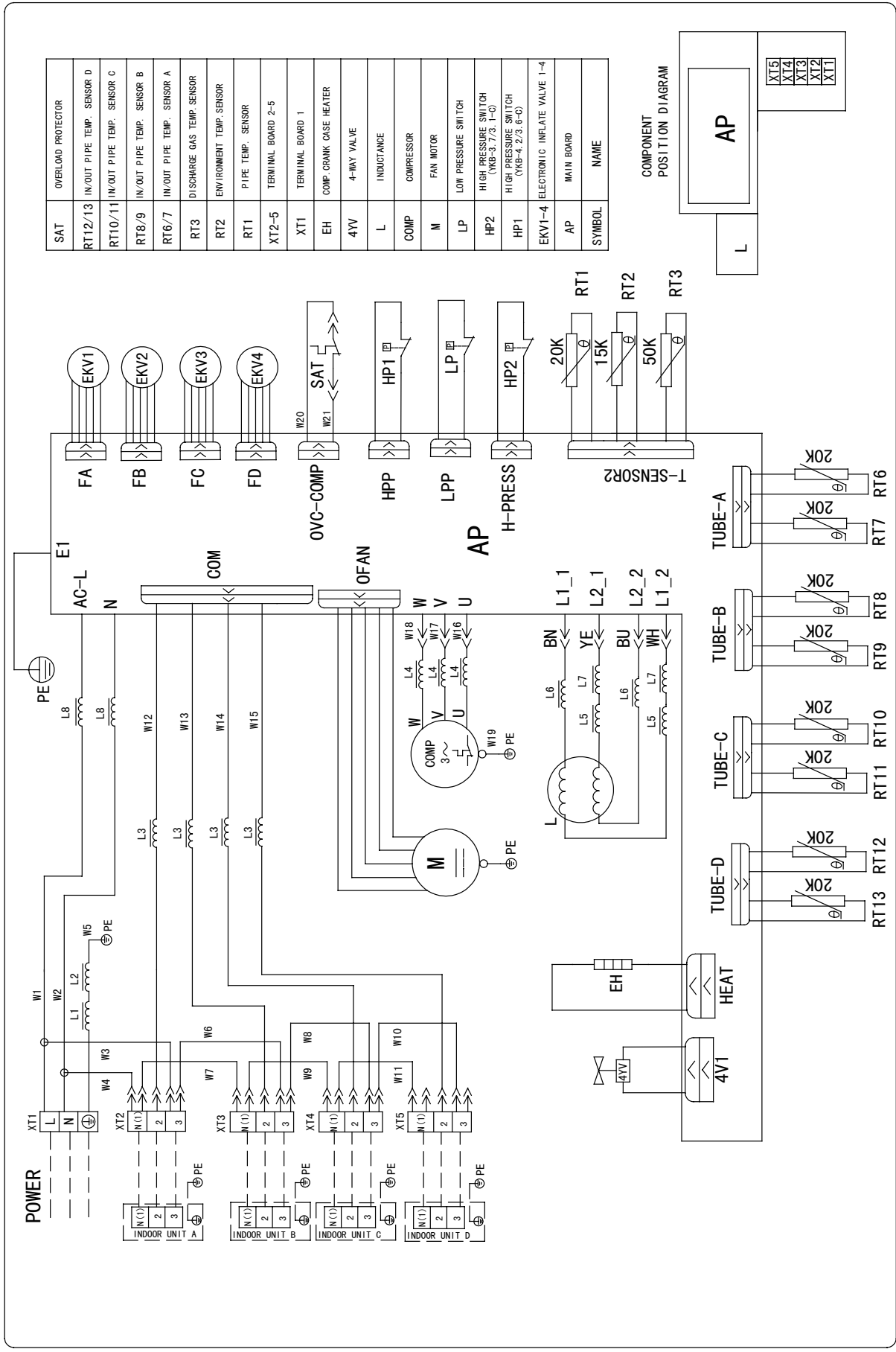

(7) Model:GWHD(42)NK3AO

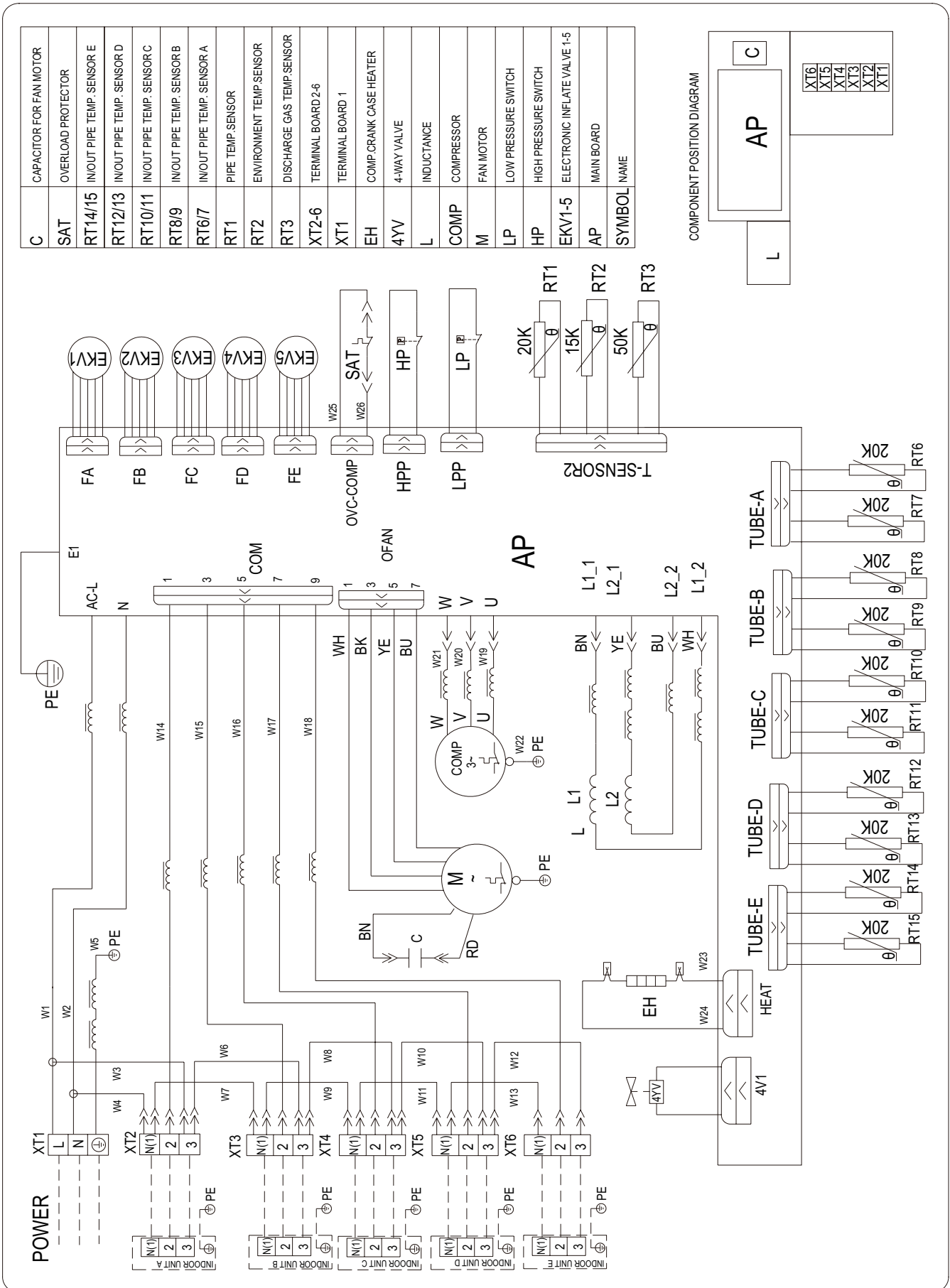

C	CAPACITOR FOR FAN MOTOR
SAT	OVERLOAD PROTECTOR
RT14/15	IN/OUT PIPE TEMP. SENSOR E
RT12/13	IN/OUT PIPE TEMP. SENSOR D
RT10/11	IN/OUT PIPE TEMP. SENSOR C
RT8/9	IN/OUT PIPE TEMP. SENSOR B
RT6/7	IN/OUT PIPE TEMP. SENSOR A
RT1	PIPE TEMP. SENSOR
RT2	ENVIRONMENT TEMP. SENSOR
RT3	DISCHARGE GAS TEMP. SENSOR
XT2-6	TERMINAL BOARD 2-6
XT1	TERMINAL BOARD 1
EH	COMP. CRANK CASE HEATER
4V1	4-WAY VALVE
L	INDUCTANCE
COMP	COMPRESSOR
M	FAN MOTOR
LP	LOW PRESSURE SWITCH
HP	HIGH PRESSURE SWITCH
EKV1-5	ELECTRONIC INFLATE VALVE 1-5
AP	MAIN BOARD
SYMBOL	NAME

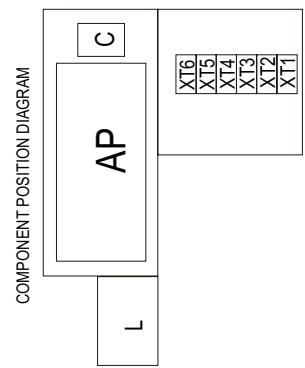

These circuit diagrams are subject to change without notice, please refer to the one supplied with the unit.

(2)Models:GWHD(24)NK3FO GWHD(24)NK3GO GWHD(28) NK3FO

• TOP VIEW

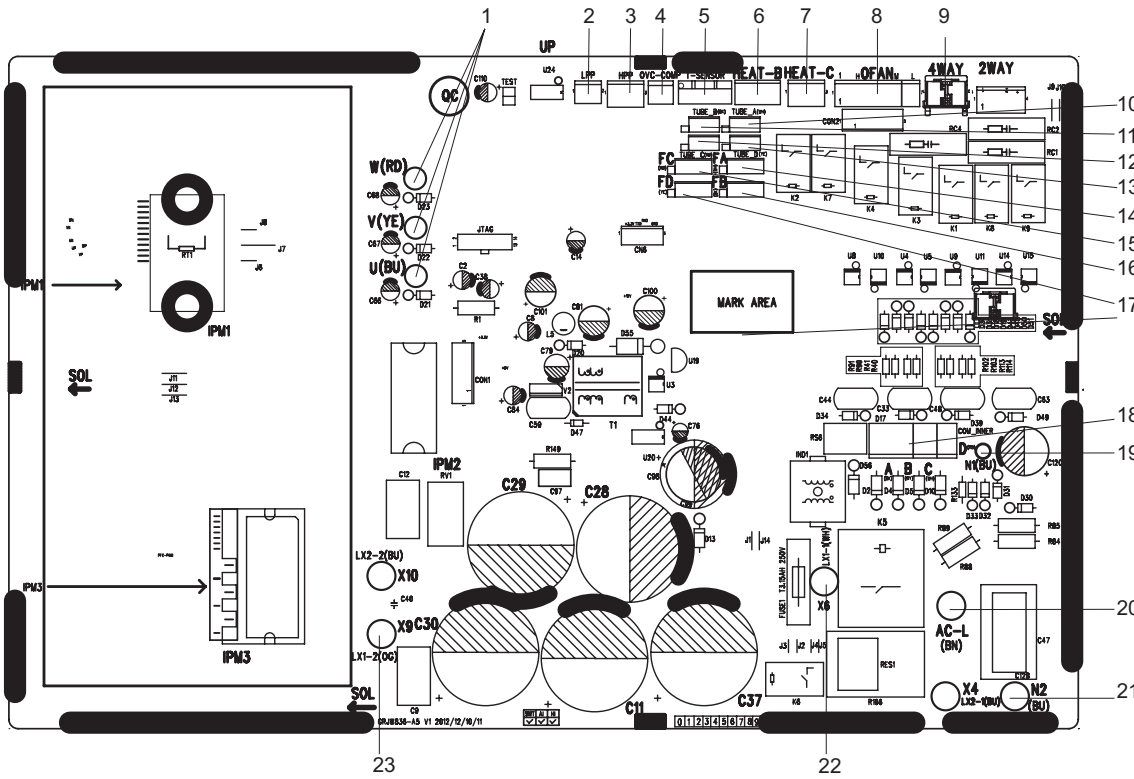

1	压缩机端子
2	低压保护端子
3	高压保护端子
4	压缩机过载保护端子
5	外机感温包端子
6	底盘电加热端子
7	压缩机电加热端子
8	外风机端子
9	四通阀端子
10	A机液阀气阀感温包
11	B机液阀气阀感温包
12	C机液阀气阀感温包
13	D机液阀气阀感温包
14	A机电膨胀阀
15	C机电膨胀阀
16	B机电膨胀阀
17	D机电膨胀阀
18	与内机通讯线
19	通讯零线
20	火线
21	零线
22	电抗器线 1
23	电抗器线 2

• BOTTOM VIEW

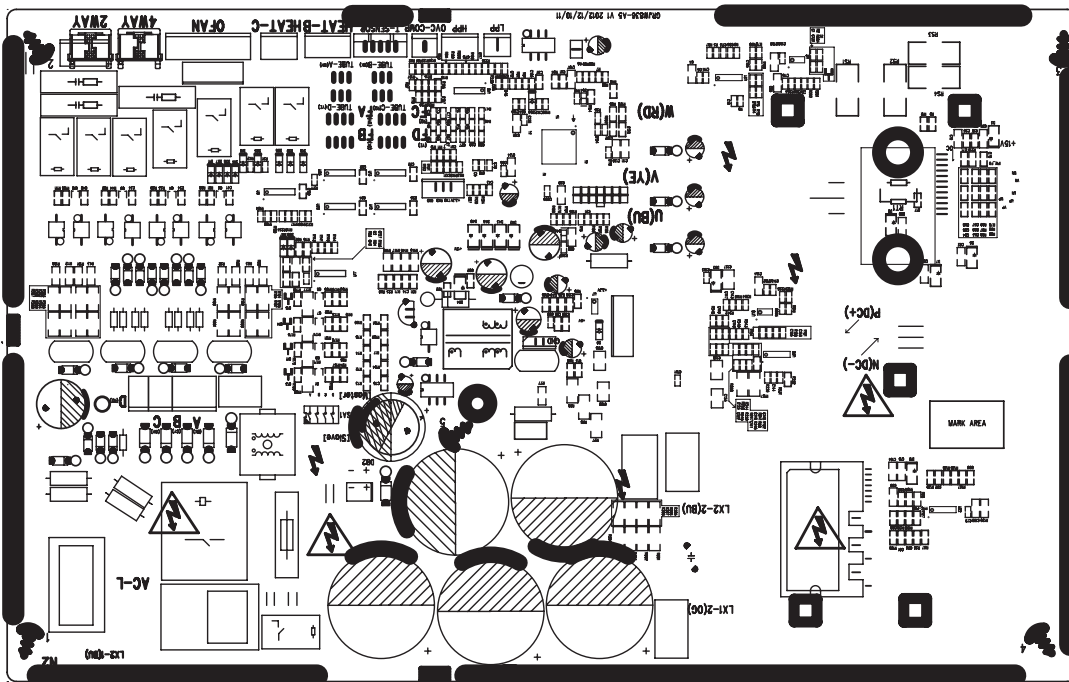

(3)Model:GWHD(36)NK3BO

• TOP VIEW

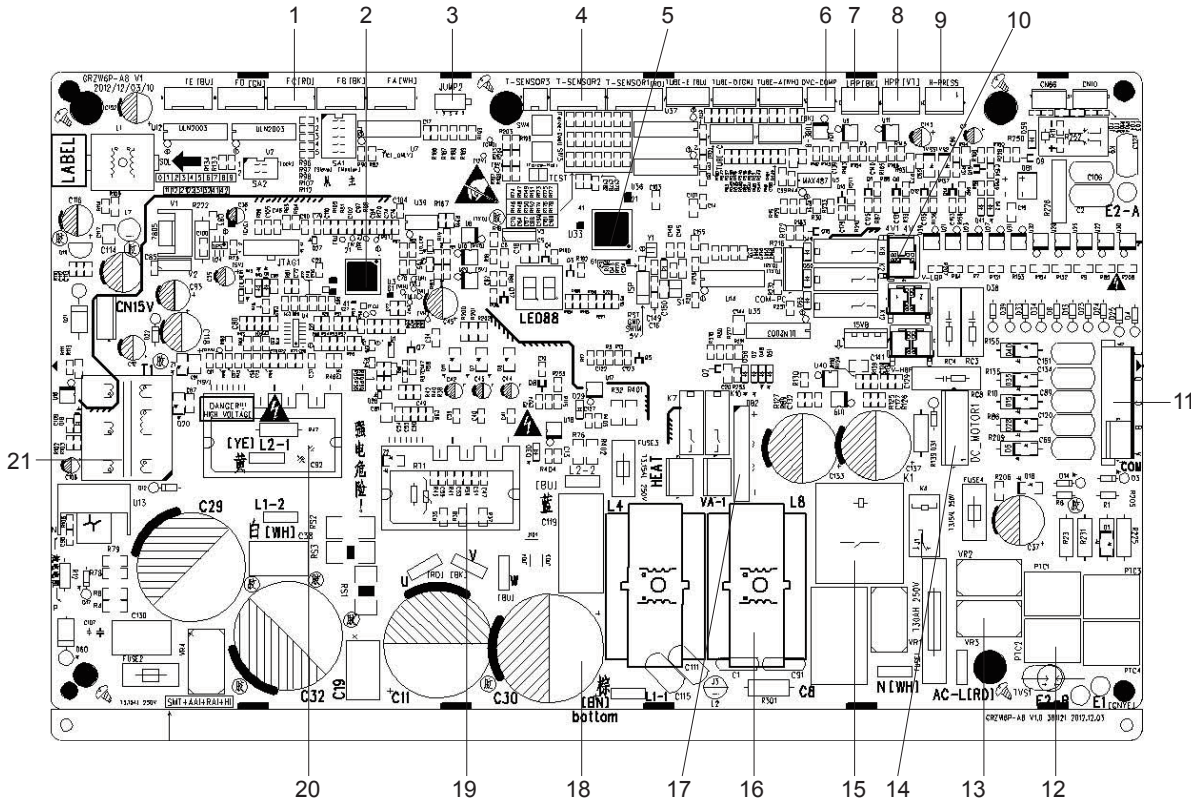

1	电子膨胀阀端子
2	G-MatrikII 芯片
3	跳线帽
4	感温包端子
5	STM8S207 芯片
6	压缩机过载保护端子
7	低压保护端子
8	高压开关 1
9	高压开关 2
10	四通阀端子
11	内外机通讯接口
12	PTC 电阻
13	压敏电阻
14	直流风机端子
15	继电器
16	共模电感
17	整流桥
18	电解电容
19	IPM 模块
20	PFC 模块
21	变压器

• BOTTOM VIEW

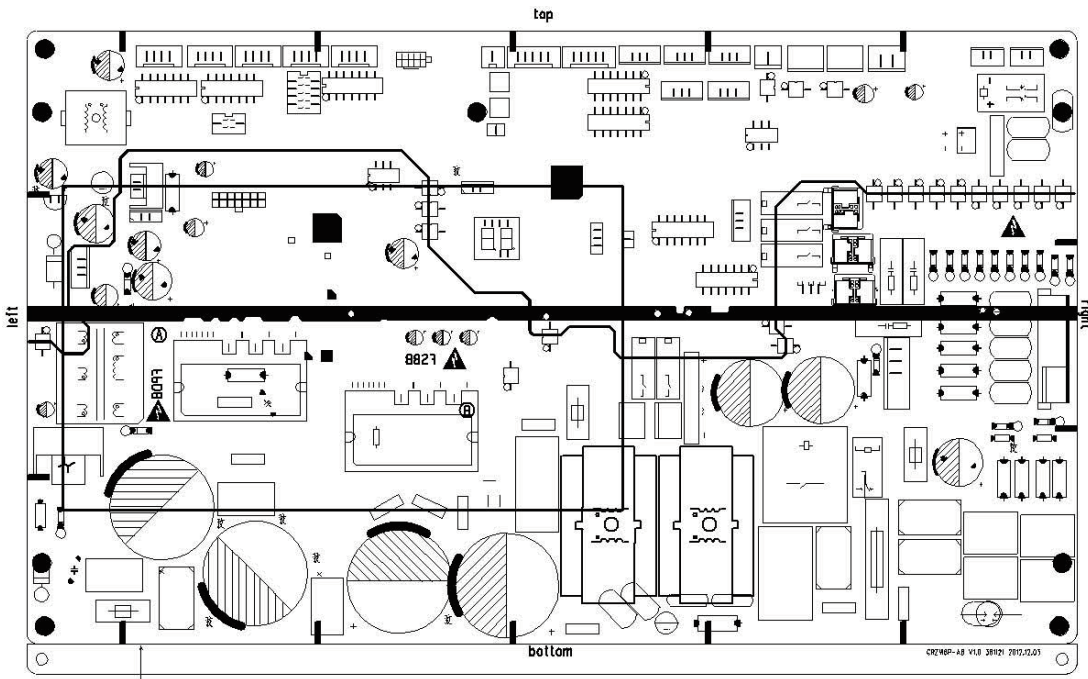

(4)Model:GWHD(42)NK3A0

● TOP VIEW

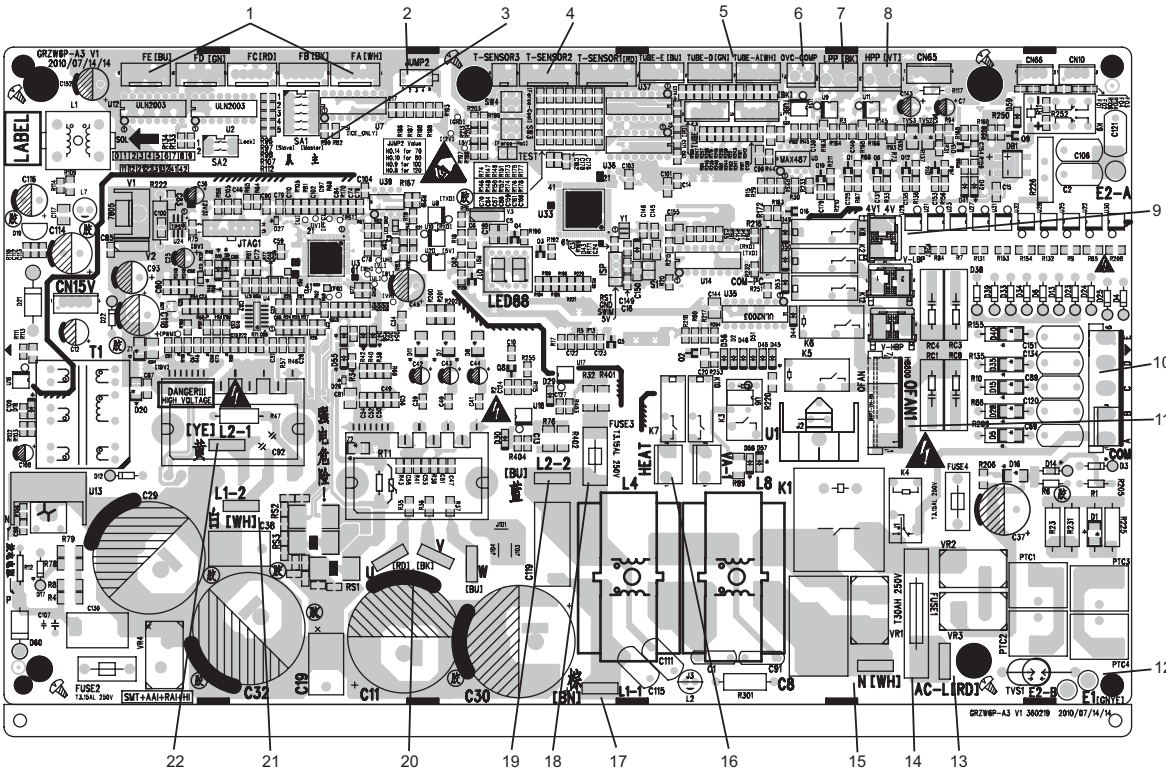

● BOTTOM VIEW

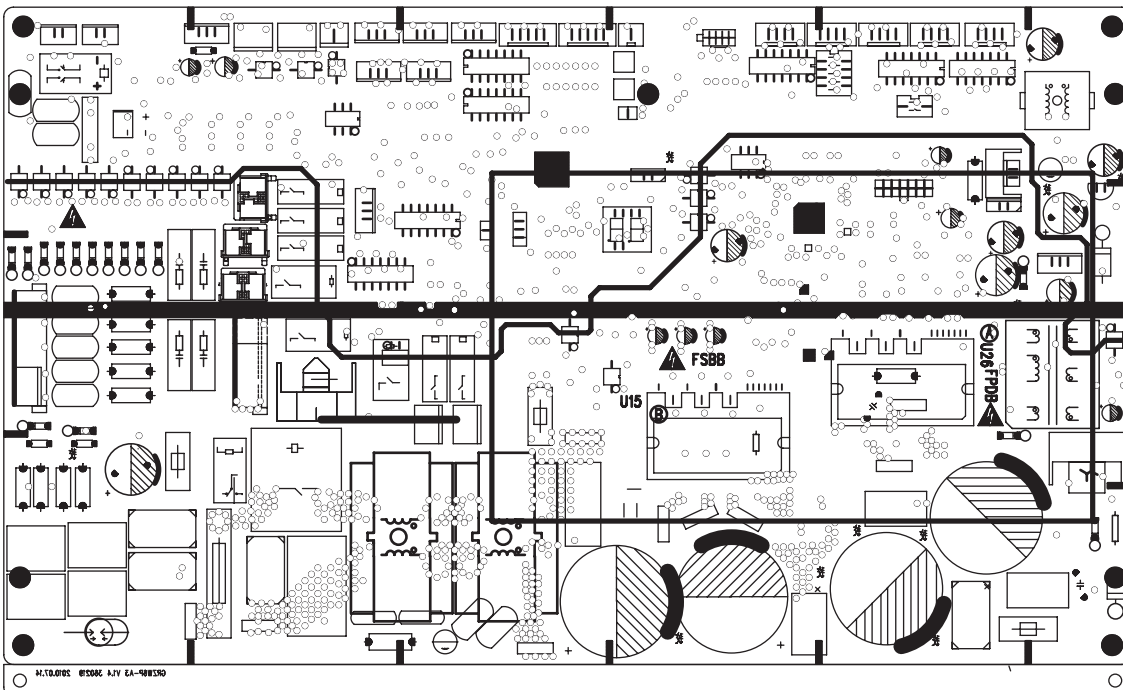

1	FA-FE: Terminals of EXV(Electronic expansion Valve)
2	JUMP2:the code of capacity
3	SA1: Master select switch
4	T-SENSOR2:Terminals of temperature sensor
5	TUBE-A - TUBE-E:Terminals of tube temperature sensor
6	OVC-COMP:Terminals of overload protector
7	LPP:Terminals of low pressure switch
8	HPP:Terminals of high pressure switch
9	4V1:Terminals of 4-way valve
10	COM:Terminals of communication
11	OFAN1:Terminals of fan
12	E1:Terminals of Earth
13	AC-L:Terminals of line wire
14	FUSE1: Fuse
15	N:Terminals of neutral wire
16	HEAT:Terminals of compressor band heater
17	L1-1:Terminals of reactor's brown wire
18	FUSE3: Fuse of fan
19	L2-2:Terminals of reactor's blue wire
20	U/V/W:Terminals of compressor
21	L1-2:Terminals of reactor's white wire
22	L2-1:Terminals of reactor's yellow wire

6. Function and Control

For 18/24/28K

1 Basic functions of the system

1.1 Cooling Mode

1.1.1 Cooling conditions and process:

If the compressor is in stop status and start the unit for cooling operation, when one of the indoor units reaches the cooling operation condition, the unit start cooling operation; in this case, the electronic expansion valve, the outdoor fan and the compressor start operation.

1.1.2 Stop in cooling operation

1.1.2.1 Compressor stops

The compressor stops immediately, the outdoor fan stops after 1min.

1.1.2.2 Some of the indoor units reach the stop condition (the compressor does not stop)

The compressor operates immediately according to the required frequency. For the indoor unit with no requirement, the corresponding electronic expansion valve is closed to OP.

1.1.3 Cooling mode transfers to heating mode

When the unit transfers to heating mode, the 4-way valve is energized after the compressor stops for 2min. The other disposals are the same as stopping in cooling mode.

1.1.4 4-way valve: in this mode, the 4-way valve is closed.

1.1.5 Outdoor fan control in cooling mode

The outdoor fan starts before 5s of the starting of compressor. The outdoor fan will run in high speed for 3min after starting and then it will run in set speed. The fan shall run at every speed for at least 80s. (When the quantity of running indoor unit is changed, the unit will enter the control described in 1.3.5.1 and 1.3.5.2);

When the compressor stops, the outdoor fan runs at present speed and stops after 1min.

1.2 Dry Mode

1.2.1 The dry conditions and process are the same as those in cooling mode;

1.2.2 The status of 4-way valve: closed;

1.2.3 The temperature setting range: 16 ~ 30℃;

1.2.4 Protection function: the same as those in cooling mode;

1.2.5 In dry mode, the maximum value A of the capacity requirement percentage of single unit is 90% of that in cooling mode.

The open condition of the electronic expansion valve, outdoor fan and compressor is the same as those in cooling mode.

1.3 Heating Mode

1.3.1 Cooling conditions and process:

When one of the indoor units reaches the heating operation condition, the unit starts heating operation.

1.3.2 Stop in heating operation:

1.3.2.1 When all the indoor units reach the stop condition, the compressor stops and the outdoor fan stops after 1min;

1.3.2.2 Some of the indoor units reach the stop condition

The compressor reduces the frequency immediately and operates according to the required frequency;

1.3.2.3 Heating mode transfers to cooling mode(dry mode), fan mode

a. The compressor stops; b. the power of 4-way valve is cut off after 2min; c. the outdoor fan stops after 1min; d. the status of 4-way valve: energized;

1.3.3 Outdoor fan control in heating mode

The outdoor fan starts before 5s of the starting of compressor and then it will run in high speed for 40s;

The fan shall run at every speed for at least 80s;

When the compressor stops, the outdoor fan stops after 1min.

1.3.4 Defrosting function

When the defrosting condition is met, the compressor stops; the electronic expansion valve of all indoor units open in big angle; the outdoor fan stops after 40s of the stop of compressor, meanwhile, the 4-way valve reverses the direction; after the 4-way valve reverses the direction, the compressor starts; then begin to calculate the time of defrosting, the frequency of the compressor rises to reach the defrosting frequency.

1.3.5 Oil-returned control in heating mode

1.3.5.1 Oil-returned condition

The whole unit is operating in low frequency for a long time

1.3.5.2 Oil-returned process in heating mode

The indoor unit displays "H1"

1.3.5.3 Oil-returned finished condition in heating mode

The duration reaches 5min

1.4 Fan Mode

The compressor, the outdoor fan and the 4-way valve are closed; temperature setting range is 16~30°C.

2. Protection Function

2.1 Mode Conflict Protection of indoor unit

When the setting mode is different of different indoor unit, the unit runs in below status:

- a. The mode of the first operating indoor unit is the basic mode, then compare the mode of the other indoor units to see if there is a conflict. Cooling mode (dry mode) is in conflict with heating mode.
- b. Fan mode is in conflict with heating mode and the heating mode is the basic mode. No matter which indoor unit operates first, the unit will run in heating mode.

2.2 Overload protection function

When the tube temperature is a little low, the compressor raises the operation frequency; when the tube temperature is a little high, the compressor frequency is restricted or lows down the operation frequency; when the tube temperature is too high, the compressor protection stops running.

If the discharge temperature protection continuously appears for 6 times, the compressor can't resume running. The compressor can resume running after cutting off the power and then putting through the power. (if the running time of the compressor is longer than 7min, the protection times record will be cleared)

2.3 Discharge Protection Function

When the discharge temperature is a little low, the compressor raises the operation frequency; when the discharge temperature is a little high, the compressor frequency is restricted or lows down the operation frequency; when the discharge temperature is too high, the compressor protection stops running.

If the discharge temperature protection continuously appears for 6 times, the compressor can't resume running. The compressor can resume running after cutting off the power and then putting through the power. (if the running time of the compressor is longer than 7min, the protection times record will be cleared)

2.4 Communication malfunction

Detection of the quantity of installed indoor units:

After 3min of energizing, if the outdoor unit does not receive the communication data of certain indoor unit, the outdoor unit will judge that indoor unit is not installed and will treat it as it is not installed. If the outdoor unit receives the communication data of that indoor unit later, the outdoor unit will treat that unit as it is installed.

2.5 Overcurrent Protection

a. Overcurrent protection of complete unit; b. phase wire current protection; c. compressor phase current protection

2.6 Compressor high-pressure protection

2.6.1 When the high-pressure switch is detected cut off for 3s continuously, the compressor will enter high-pressure protection as it stops when reaching set temperature. Meanwhile, the outdoor unit will send the signal of "high-pressure protection" to the indoor units;

2.6.2 After the appearance of high-pressure protection, when the high-pressure switch is detected closed for 6s continuously, the compressor can resume running only after cutting off the power and then putting through the power.

2.7 Compressor overload protection

If the compressor overload switch is detected having movement, the indoor unit will display the corresponding malfunction as it stops when the indoor temperature reaching set temperature. When the compressor stops for more than 3min and the compressor overload switch is reset, the unit will resume operation status automatically. If the protection appears for more than 6 times (if the running time of the compressor is longer than 30min, the protection times record will be cleared), the unit can not resume operation status automatically, but can resume running only after cutting off the power and then putting through the power.

2.8 Compressor Phase-lacking Protection

When the compressor starts, if one of the three phases is detected open, the compressor will enter phase-lacking protection. The malfunction will be cleared after 1min, the unit will restart and then detect if there is still has phase-lacking protection. If the phase-lacking protection is detected for 6 times continuously, the compressor will not restart but can resume running only after cutting off the power and then putting through the power. If the running time of the compressor is longer than 7min, the protection times record will be cleared.

2.9 IPM Protection

2.9.1 When the IMP module protection is detected, the unit will stop as the indoor temperature reaching set temperature, PFC is closed, display IMP protection malfunction. After the compressor stops for 3min, the unit will resume operation status automatically; if the IMP protection is detected for more than 6 times continuously (If the running time of the compressor is longer than 7min, the protection times record will be cleared), the system will stop and send the signal of module protection to indoor unit. The unit can not resume operation status automatically, but can resume running only after cutting off the power and then putting through the power.

2.9.2 IMP module overheating protection

2.9.2.1 When $T_{IMP} > 85^{\circ}\text{C}$, prohibit to raise frequency;

2.9.2.2 When $T_{IMP} \geq 90^{\circ}\text{C}$, the operation frequency of compressor lows down by 15% every 90s according to the present capacity requirement of the complete unit. It will keep 90s after lowering down the frequency. After lowering down the frequency, if $T_{IMP} \geq 90^{\circ}\text{C}$, the unit will circulate the above movement until reaching the minimum frequency; if $85^{\circ}\text{C} < T_{IMP} < 90^{\circ}\text{C}$, the unit will run at this frequency; when $T_{IMP} \leq 85^{\circ}\text{C}$, the unit will run at the frequency according to the capacity requirement;

2.9.2.3 When $T_{IMP} \geq 95^{\circ}\text{C}$, the compressor stops. After the compressor stops for 3min, if $T_{IMP} < 85^{\circ}\text{C}$, the compressor and the outdoor fan will resume operation.

For 36K/42K

1. Function Control

1) Cooling mode

- a. Turning on the unit for cooling operation, and if any one of the indoor units satisfy the cooling operation condition, the system will start for cooling operation; and the electronic expansion valve, the outdoor fan and the compressor start operation.
- b. When some of the indoor units satisfy the stop-condition while some indoor units does not satisfy the stop-condition, the compressor does not stop, the compressor adjust the frequency according to demand. For the indoor unit with stop-condition satisfies, the corresponding electronic expansion valve will be closed.
- c. Change Cooling mode to heating mode

When change the unit to heating mode from cooling mode, the whole system will stop first. Then the system will restart in heating mode after the compressor stops.

d. 4-way valve

In this mode, the 4-way valve is closed.

e. Outdoor fan control in cooling mode

The outdoor fan starts before 5s of the starting of compressor. The outdoor fan will run in middle speed after starting and then it will run in set speed.

2) Dry mode (dehumidification mode)

this mode is the same as cooling mode;

3) Heating mode

- a. Turning on the unit for heating operation, If any one of the indoor unit satisfy the heating condition, the system will start to run in heating mode
- b. If all the indoor units satisfy the stop-condition, the compressor stops and the outdoor fan stops after 1min;
- c. If only part of the indoor units satisfy the stop-condition, the compressor decrease the frequency immediately and operates according to demand.
- d. Change Heating mode to cooling mode or dehumidification mode, the whole system will stop first, then restart under the required mode.

e. Defrosting function

When the defrosting condition is satisfied, the 4-way valve reverses the direction, the outdoor fan stop. After the 4-way valve reverses the direction, the frequency of compressor rises, and the unit will start defrosting under cooling cycle.

f. Oil-return control in heating mode

a) If the whole system runs in low frequency for a long time, the system will run a oil-return operation in high frequency, the indoor unit displays "H1", the oil-return operation will runs for 3 minutes.

4) Fan mode

Only indoor fan run. Compressor, outdoor fan and 4-way valve are closed .

2. Protection Function

1) Mode conflict protection of indoor units

When the setting mode is different of different indoor unit, the unit runs in below status:

- a. The system mode is determined by the first turning on indoor unit except indoor unit is in fan mode. Cooling mode (dry mode) is in conflict with heating mode.
- b. If the first turning on unit is fan mode, and the second turning on unit is cooling or heating mode, then the system will run in cooling or heating mode

2) Overload protection

If the tube temperature at the high pressure side is higher than normal, the compressor frequency is restricted or decreased to normal operation frequency.

3) High exhaust temperature protection

If the exhaust temperature is higher than protection value, the compressor stops running.

If the exhaust temperature protection continuously appears for 6 times, the compressor can't resume running. In this case, only by cutting off the power and then reenergize that the compressor can restart. If the running duration of the compressor is longer than 7min, the protection times will be cleared to zero time.

4) Communication malfunction

Detection of the quantity of installed indoor units: after 3min of energizing, if the outdoor unit does not receive the communication data of certain indoor unit, the outdoor unit will judge that indoor unit is not installed. If the outdoor unit receives the communication data of that indoor unit later, the communication malfunction will be cleared.

5) System high-pressure protection

- a. When the high-pressure switch detects the system pressure higher than limit ,then the high-pressure switch cuts off, the system will stop to run.
- b.If high-pressure protection is detected for two times within one hour, only by cutting off the power and then reenergize that the compressor can restart.

6)System low-pressure protection

- a. When the low-pressure switch detects the system pressure lower than limit ,then the low-pressure switch cuts off , the system will stop to run.
- b. If low-pressure protection is detected for two times within one hour, only by cutting off the power and then reenergize that the compressor can restart.

7) Compressor overload protection

No matter the compressor is on or off, when the compressor overload switch is detected activated, the system will stop and indoor unit will display H3. If the compressor overload protection appears for more than 6 times, in this case, only by cutting off the power and then reenergize that the compressor can restart. If the running duration of the compressor is longer than 30min, the protection times will be cleared to zero.

3.Other function

1) Refrigerant Recovery

When the unit is powered on and runs under the COOL mode, it is available within five minute to go the refrigerant recovery mode by pressing three times the "LIGHT" button on the wireless controller in three seconds with "Fo" displayed.

How to quit the refrigerant recovery:

When the refrigerant recovery has started, it will quit when there is a signal from the wireless controller or it has run for ten minutes.

2) Setting function of master/slave indoor unit

Picture of DIP switch on outdoor mainboard :

SA1(5-bit): dial-switch for master/slave indoor unit,

SA2(2-bit): dial-switch for mode locking (not for wall mounted indoor units)

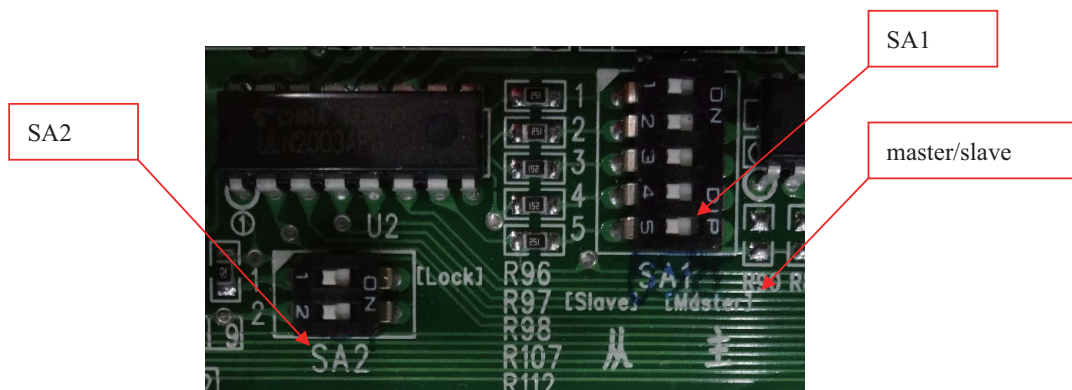

5-bit dial-switch to set master/slave indoor unit: it is corresponding to indoor units of no.1 to no.5. Dial the switch to ON(master side. Right side) to set that indoor unit as master indoor unit , and dial the switch to slave side(left side) to set indoor unit as slave indoor unit. There can be only one master unit in a system, If more than one indoor units are set as master unit, the unit with smallest number is the master unit. (smallest number here means number 1 to number 5 on the switch)

2-bit dial-switch to set mode locking

(note:

1.only use no.1 bit. no.2 bit is for future use

2.this function is only for duct and cassette unit, not for wall mounted unit:

Locked mode: Switch no.1 bit to "ON"side(lock side, or right side on the picture): even the master indoor unit is off, the system will run according to the mode before the master unit off.

Unlocked mode: Switch no.1 bit to left side on the picture: If the master indoor unit is off , the system will not care what the master unit mode was, it will run according to the mode of the first turning on slave indoor unit.

Note: For wall-mounted indoor unit, unlocked model is default, and locked mode is invalid.

Part II : Installation and Maintenance

7. Notes for Installation and Maintenance

Safety Precautions: Important!

Please read the safety precautions carefully before installation and maintenance.

The following contents are very important for installation and maintenance.

Please follow the instructions below.

- The installation or maintenance must accord with the instructions.
- Comply with all national electrical codes and local electrical codes.
- Pay attention to the warnings and cautions in this manual.
- All installation and maintenance shall be performed by distributor or qualified person.
- All electric work must be performed by a licensed technician according to local regulations and the instructions given in this manual.
- Be caution during installation and maintenance. Prohibit incorrect operation to prevent electric shock, casualty and other accidents.



Warnings

Electrical Safety Precautions:

1. Cut off the power supply of air conditioner before checking and maintenance.
2. The air condition must apply specialized circuit and prohibit share the same circuit with other appliances.
3. The air conditioner should be installed in suitable location and ensure the power plug is touchable.
4. Make sure each wiring terminal is connected firmly during installation and maintenance.
5. Have the unit adequately grounded. The grounding wire can't be used for other purposes.
6. Must apply protective accessories such as protective boards, cable-cross loop and wire clip.
7. The live wire, neutral wire and grounding wire of power supply must be corresponding to the live wire, neutral wire and grounding wire of the air conditioner.
8. The power cord and power connection wires can't be pressed by hard objects.
9. If power cord or connection wire is broken, it must be replaced by a qualified person.

10. If the power cord or connection wire is not long enough, please get the specialized power cord or connection wire from the manufacture or distributor. Prohibit prolong the wire by yourself.

11. For the air conditioner without plug, an air switch must be installed in the circuit. The air switch should be all-pole parting and the contact parting distance should be more than 3m.

12. Make sure all wires and pipes are connected properly and the valves are opened before energizing.

13. Check if there is electric leakage on the unit body. If yes, please eliminate the electric leakage.

14. Replace the fuse with a new one of the same specification if it is burnt down; don't replace it with a cooper wire or conducting wire.

15. If the unit is to be installed in a humid place, the circuit breaker must be installed.

Installation Safety Precautions:

1. Select the installation location according to the requirement of this manual.(See the requirements in installation part)
2. Handle unit transportation with care; the unit should not be carried by only one person if it is more than 20kg.
3. When installing the indoor unit and outdoor unit, a sufficient fixing bolt must be installed; make sure the installation support is firm.
4. Ware safety belt if the height of working is above 2m.
5. Use equipped components or appointed components during installation.
6. Make sure no foreign objects are left in the unit after finishing installation.

Refrigerant Safety Precautions:

1. Avoid contact between refrigerant and fire as it generates poisonous gas; Prohibit prolong the connection pipe by welding.
2. Apply specified refrigerant only. Never have it mixed with any other refrigerant. Never have air remain in the refrigerant line as it may lead to rupture or other hazards.
3. Make sure no refrigerant gas is leaking out when installation is completed.
4. If there is refrigerant leakage, please take sufficient measure to minimize the density of refrigerant.
5. Never touch the refrigerant piping or compressor without wearing glove to avoid scald or frostbite.

Improper installation may lead to fire hazard, explosion, electric shock or injury.

Main Tools for Installation and Maintenance

<p>1. Level meter, measuring tape</p> 	<p>2. Screw driver</p> 	<p>3. Impact drill, drill head, electric drill</p> 
<p>4. Electroprobe</p> 	<p>5. Universal meter</p> 	<p>6. Torque wrench, open-end wrench, inner hexagon spanner</p> 
<p>7. Electronic leakage detector</p> 	<p>8. Vacuum pump</p> 	<p>9. Pressure meter</p> 
<p>10. Pipe pliers, pipe cutter</p> 	<p>11. Pipe expander, pipe bender</p> 	<p>12. Soldering appliance, refrigerant container</p> 

8. Installation Manual

Installation procedures

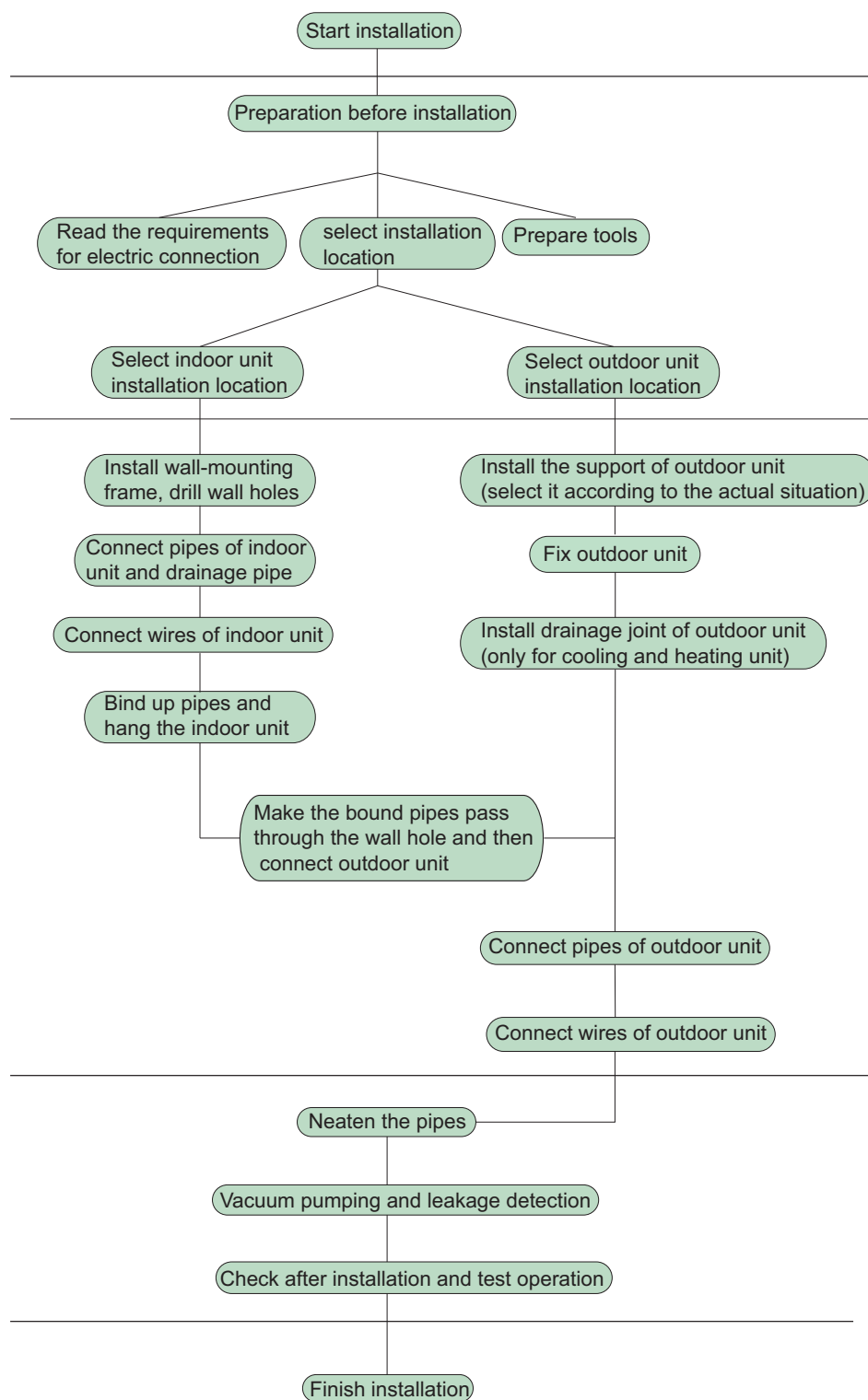

Note: this flow is only for reference; please find the more detailed installation steps in this section.

8.1 Electrical Connections

GWHD(18)NK3FO GWHD(24)NK3FO

1. Remove the handle at the right side plate of the outdoor unit (one screw).
2. Remove the cable clamp, connect the power connection cable with the terminal at the row of connection and fix the connection. The fitting line distributing must be consistent with the indoor unit. terminal of line bank. Wiring should meet that of indoor unit.
3. Fix power connection wire by wire clamp.
4. Ensure wire has been fixed well.
5. Install the handle.

! Including an air switch with suitable capacity, please note the following table. Air switch should be included magnet buckle and heating buckle function, it can protect the circuit-short and overload. (Caution: please do not use the fuse only for protect the circuit)

Air-conditioner	Air switch capacity
GWHD(18)NK3FO	20A
GWHD(24)NK3FO	25A

! An all-pole disconnection switch having a contact separation of at least 3mm in all pole should be connected in fixed wiring.

! Wrong wire connection may cause malfunction of some electric components. After fixing cable, ensure that leads between connection to fixed point have some space.

! The connection pipes and the connecting wirings of the unit A and unit B must be corresponding to each other respective.

! The appliance shall be installed in accordance with national wiring regulations.

Note: the above figures are only intended to be a simple diagram of the appliance and may not correspond to the appearance of the units that have been purchased.

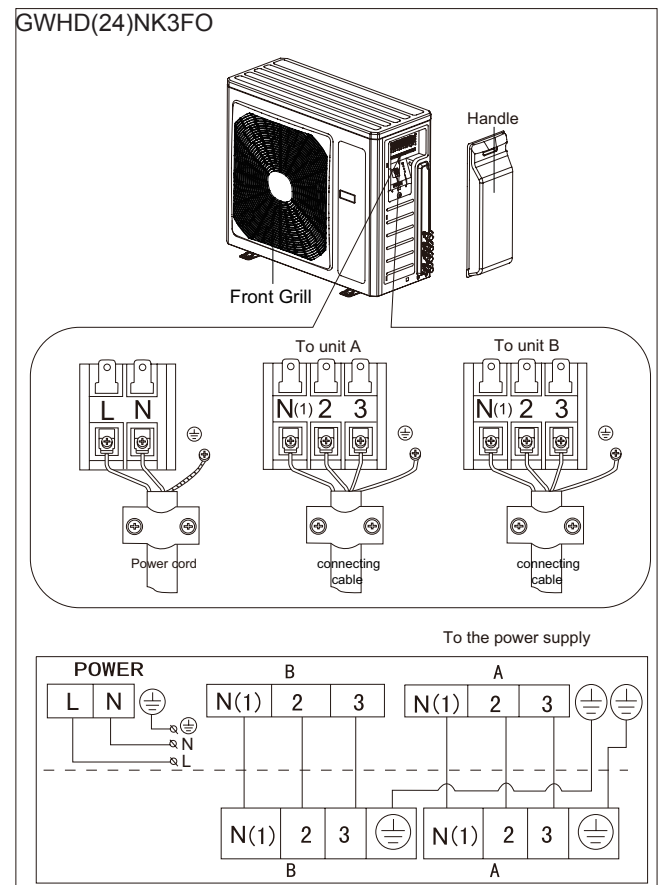
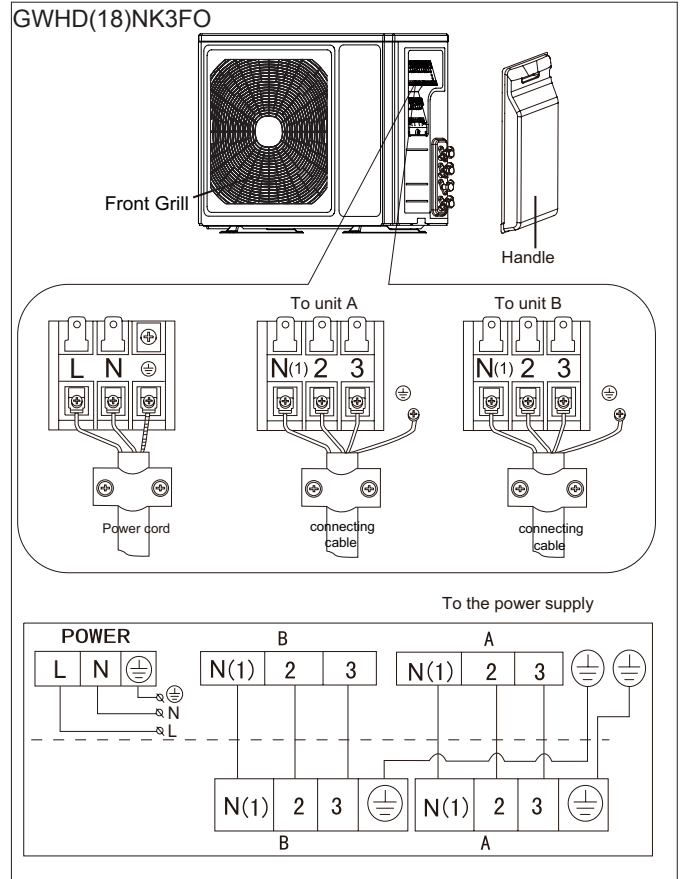

GWHD(24)NK3GO

1. Remove the handle at the right side plate of the outdoor unit (one screw).
2. Remove the cable clamp, connect the power connection cable with the terminal at the row of connection and fix the connection. The fitting line distributing must be consistent with the indoor unit. terminal of line bank. Wiring should meet that of indoor unit.
3. Fix power connection wire by wire clamp.
4. Ensure wire has been fixed well.
5. Install the handle.

! Including an air switch with suitable capacity, please note the following table. Air switch should be included magnet buckle and heating buckle function, it can protect the circuit-short and overload. (Caution: please do not use the fuse only for protect the circuit)

Air-conditioner	Air switch capacity
GWHD(24)NK3GO	25A

! An all-pole disconnection switch having a contact separation of at least 3mm in all pole should be connected in fixed wiring.

! Wrong wire connection may cause malfunction of some electric components. After fixing cable, ensure that leads between connection to fixed point have some space.

! The connection pipes and the connecting wirings of the unit A, unit B, unit C and unit D must be corresponding to each other respective.

! The appliance shall be installed in accordance with national wiring regulations.

Note: The above figures are only intended to be a simple diagram of the appliance and may not correspond to the appearance of the units that have been purchased.

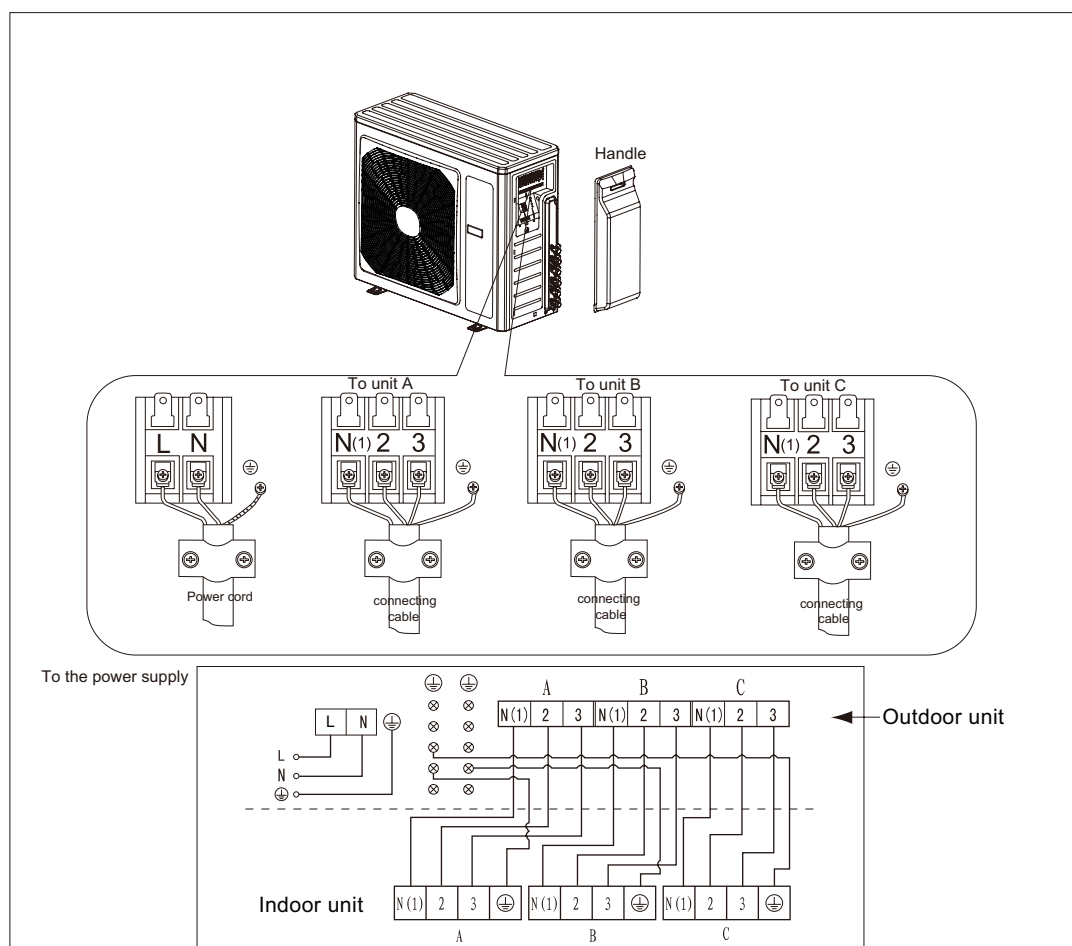

GWHD(28) NK3FO

1. Remove the handle at the right side plate of the outdoor unit (one screw).
2. Remove the cable clamp, connect the power connection cable with the terminal at the row of connection and fix the connection. The fitting line distributing must be consistent with the indoor unit. terminal of line bank. Wiring should meet that of indoor unit.
3. Fix power connection wire by wire clamp.
4. Ensure wire has been fixed well.
5. Install the handle.

! Including an air switch with suitable capacity, please note the following table. Air switch should be included magnet buckle and heating buckle function, it can protect the circuit-short and overload. (Caution: please do not use the fuse only for protect the circuit)

Air-conditioner	Air switch capacity
GWHD(28)NK3FO	25A

! An all-pole disconnection switch having a contact separation of at least 3mm in all pole should be connected in fixed wiring.

! Wrong wire connection may cause malfunction of some electric components. After fixing cable, ensure that leads between connection to fixed point have some space.

! The connection pipes and the connecting wirings of the unit A, unit B, unit C and unit D must be corresponding to each other respective.

! The appliance shall be installed in accordance with national wiring regulations.

Note: The above figures are only intended to be a simple diagram of the appliance and may not correspond to the appearance of the units that have been purchased.

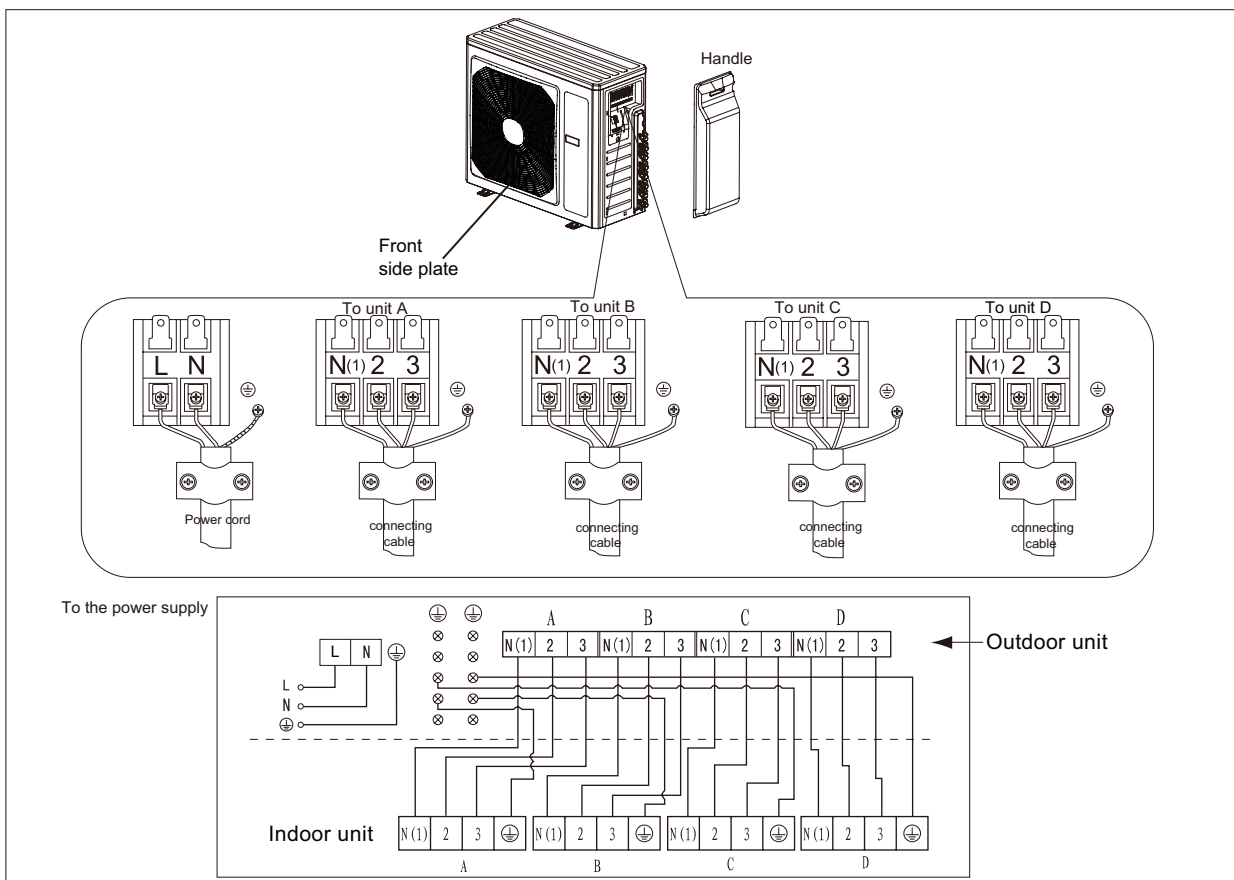

8.2 Installing the Outdoor Unit

! Use bolts to secure the unit to a flat, solid floor. When mounting the unit on a wall or the roof, make sure the support is firmly secured so that it cannot move in the event of intense vibrations or a strong wind.

Do not install the outdoor unit in pits or air vents
Installing the pipes

! Use suitable connecting pipes and equipment for the refrigerant R410A.

Models(m)	18K	24K	24K	28K
Max. connection pipe length	20	20	60	70
Max. connection pipe length(Simple one indoor unit)	10	10	20	20

! The refrigerant pipes must not exceed the maximum heights 10m.

! Wrap all the refrigerant pipes and joints.

! Tighten the connections using two wrenches working in opposite directions.

Caution: Installation Must be Performed in Accordance with the NEC/CEC by Authorized Personnel Only.

Humid air left inside the refrigerant circuit can cause compressor malfunction. After having connected the indoor and outdoor units, bleed the air and humidity from the refrigerant circuit using a vacuum pump.

1. Unscrew and remove the caps from the 2-way and 3-way valves.
2. Unscrew and remove the cap from the service valve.
3. Connect the vacuum pump hose to the service valve.
4. Operate the vacuum pump for 10-15 minutes until an absolute vacuum of 10 mm Hg has been reached.
5. With the vacuum pump still in operation, close the low-pressure knob on the vacuum pump coupling. Stop the vacuum pump.
6. Open the 2-way valve by 1/4 turn and then close it after 10 seconds. Check all the joints for leaks using liquid soap or an electronic leak device.
7. Turn the body of the 2-way and 3-way valves. Disconnect the vacuum pump hose.
8. Replace and tighten all the caps on the valves.

Diameter (mm)	Twisting moment (N.m)
Φ6	15-20
Φ9.52	35-40
Φ16	60-65
Φ12	45-50
Φ19	70-75

18K unit need to be installed the indoor unit

18K Model:

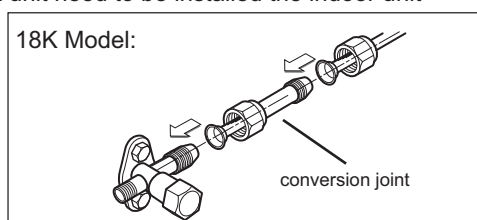

Install the drain fitting and the drain hose (for model with heat pump only)

Condensation is produced and flows from the outdoor unit when the appliance is operating in the heating mode. In order not to disturb neighbours and to respect the environment, install a drain fitting and a drain hose to channel the condensate water. Install the drain fitting and rubber washer on the outdoor unit chassis and connect a drain hose to it as shown in the figure.

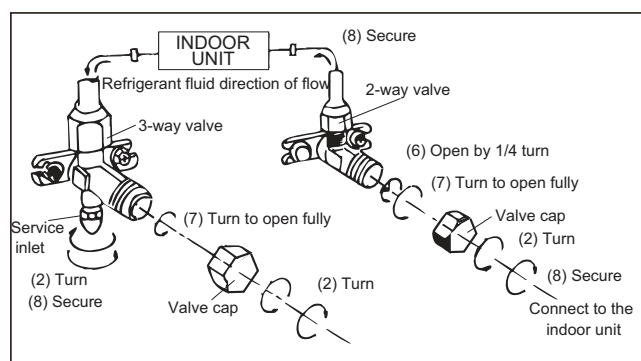
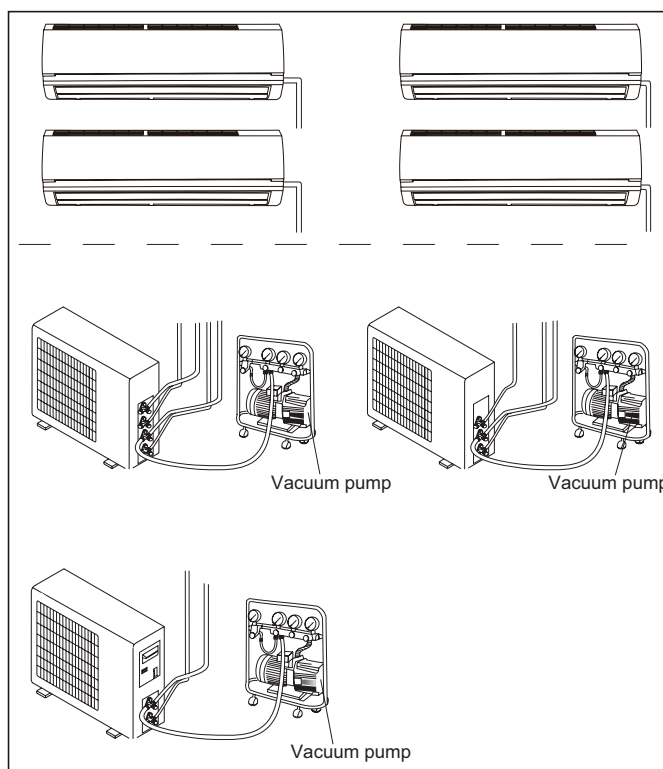
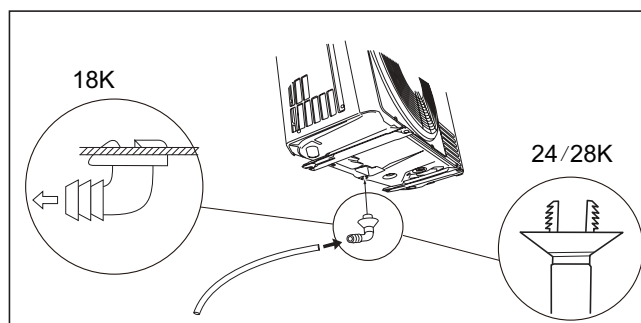

8.3 Installation Dimension Diagram

! Use suitable instruments for the refrigerant R410A.

- Do not use any other refrigerant than R410A.

! Do not use mineral oils to clean the unit.

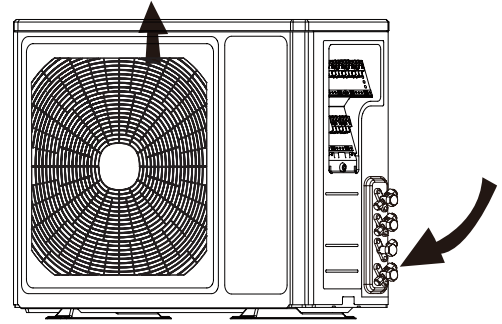

! The installation must be done by trained and qualified service personnel with reliability according to this manual.

! Contact service center before installation to avoid the malfunction due to unprofessional installation.

! When picking up and moving the units, you must be guided by trained and qualified person.

! Ensure that the recommended space is left around the appliance.

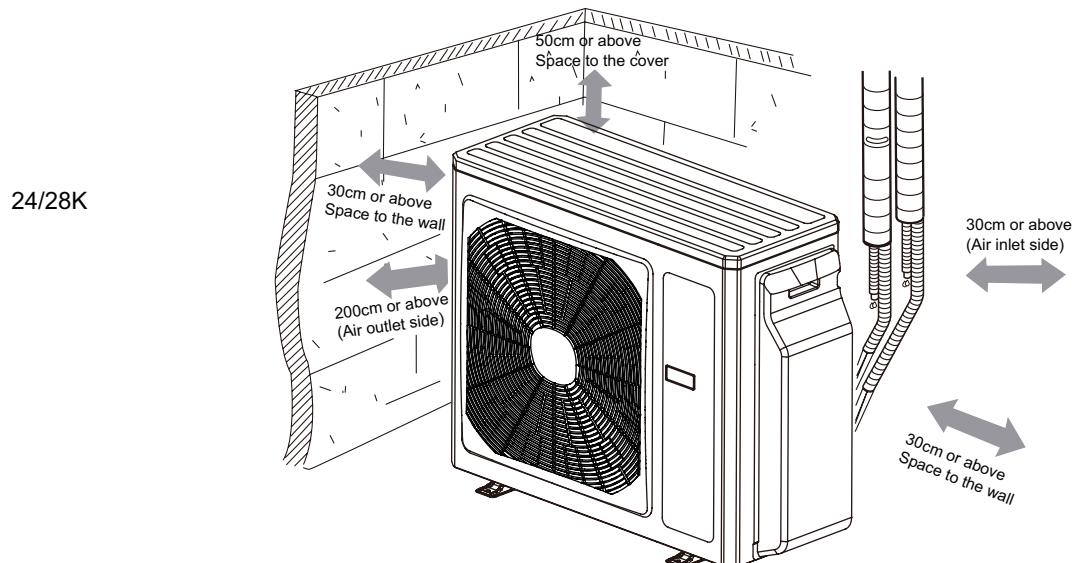
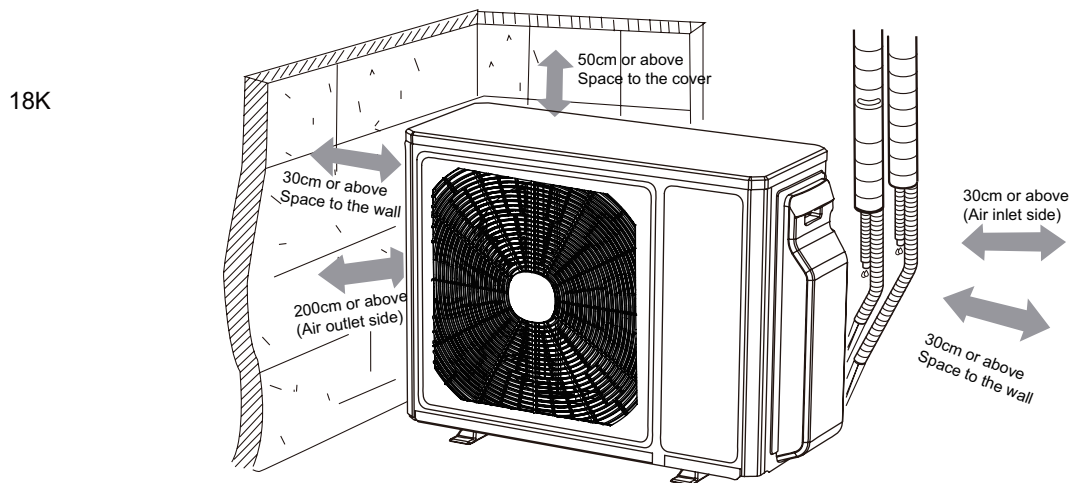

8.4 Check after Installation

Check Items	Problems Owing to Improper Installation
Is the installation reliable?	The unit may drop, vibrate or make noises
Has the gas leakage been checked?	May cause unsatisfactory cooling (heating) effect
Is the thermal insulation of the unit sufficient?	May cause condensation and water dropping
Is the drainage smooth?	May cause condensation and water dropping
Does the power supply voltage accord with the rated voltage specified on the nameplate?	The unit may bread down or the components may be burned out
Are the lines and pipelines correctly installed?	The unit may bread down or the components may be burned out
Has the unit been safely grounded?	Risk of electrical leakage
Are the models of lines in conformity with requirements?	The unit may bread down or the components may be burned out
Are there any obstacles near the air inlet and outlet of the indoor and outdoor units?	The unit may bread down or the components may be burned out
Have the length of refrigerating pipe and refrigerant charge amount been recorded?	It is not easy to decide the charge amount of refrigerant.

36K and 42K

Safety Precautions

Please read this manual carefully before using and operating correctly as instructed in this manual.
Please especially take notice of the following two symbols:

 **Warning!** It indicates improper operation which will lead to human casualty or severe injury.

 **Caution!** It indicates improper operation which will lead to injury or property damage.

 **Warning!**

- ◆ The installation should be committed to the appointed service center; otherwise it will cause water leakage, electric shock or fire etc.
- ◆ Please install the unit in a place where is strong enough to withstand the weight of the unit; otherwise, the unit would fall down and cause injury or death.
- ◆ The drain pipe should be installed as instructed in the manual to guarantee the proper drainage; meanwhile it should be insulated to prevent condensing; otherwise the improper installation would cause water leakage and then wet the household wares in the room.
- ◆ Do not use or place any inflammable or explosive substance near the unit.
- ◆ Under the occurrence of an error (like burning smell etc.), please cut off the main power supply of the unit.
- ◆ Keep good ventilation in the room to avoid oxygen deficit.
- ◆ Never insert your finger or any other object into the air outlet/inlet grille.
- ◆ Please take notice of the supporting frame of the unit to see if it is damaged over the long time period of use.
- ◆ Never refit the unit and contact the sales agent or the professional installation personnel for the repair or relocation of the unit.
- ◆ Non-professional personnel are prohibited to dismantle the electric box owing to the high voltage of the outdoor unit.

An all-pole disconnection switch having a contact separation of at least 3mm in all poles should be connected in fixed wiring.

 **Caution!**

- ◆ Before installation, please check if the power supply corresponds with the requirement specified on the nameplate and also check its security.
- ◆ Before using the unit, please check if the piping and wiring are correct to avoid water leakage, refrigerant leakage, electric shock, or fire etc.
- ◆ The main power supply must be earthed to avoid the hazard of electric shock and never connect this earth wire to the gas pipe, running water pipe, lightning rod or phone cable's earth lead.
- ◆ Turn off the unit after it runs at least five minutes; otherwise its service life will be shortened.
- ◆ Do not allow children operate this unit.
- ◆ Do not operate this unit with wet hands.
- ◆ Cut off the main power supply prior to the cleaning of the unit or the replacement of the air filter.
- ◆ When the unit is not to be used for a long time, please cut off the main power supply of the unit.
- ◆ Do not expose the unit to the moist or corrosive circumstances.
- ◆ Never step on the unit or place any object on it.
- ◆ It is suggested to have a power-on test annually.

8.5.1 Installation Location and Matters Needing Attention

The installation of the unit must comply with the national and local safety regulations. The installation quality directly affects the normal use, so the user should not carry out the installation personally, instead, the installation and debugging should be done by technician according to this manual. Only after that, can the unit be energized.

- a. How to select the installation location for the indoor unit
 - 1) Where there is no direct sunlight.
 - 2) Where the top hanger, ceiling and the building structure are strong enough to withstand the weight of the unit.
 - 3) Where the drain pipe can be easily connected to outside.
 - 4) Where the flow of the air inlet/outlet is not blocked.
 - 5) Where the refrigerant pipe of the indoor unit can be easily led to outside.
 - 6) Where there is no inflammable, explosive substances or their leakage.
 - 7) Where there is no corrosive gas, heavy dust, salt mist, smog or moisture.
- b. How to select the installation location for the outdoor unit
 - 1) The outdoor unit must be installed where the bearing surface is stable and secure enough.
 - 2) The outdoor unit and indoor unit should be placed as close as possible to minimize the length and bends of the refrigerant pipe.
 - 3) Do not install the outdoor unit under the window or between the buildings to prevent the normal running noise entering the room.
 - 4) Where the flow of the air inlet/outlet is not blocked.
 - 5) The outdoor unit should be installed where ventilation is in good condition so that the unit can take in and discharge enough air.
 - 6) Do not install the unit where there are inflammable and explosive substances and where there is heavy dust, salt fog and other severely polluted air.

No air guiding pipe is allowed to be installed at the air inlet/outlet of the outdoor unit. Under the heating mode, the condensate water would drip down from the base frame and would be frozen when the outdoor ambient temperature is lower than 0°C (32 °F) . Besides, the installation of the outdoor unit should not affect the heat radiation of the unit.

⚠CAUTION!

The unit installed in the following places is likely to run abnormally. If unavoidable, please contact the professional personnel at the GREE appointed service center. ① where is full of oil; ② alkaline soil off the sea; ③ where there is sulfur gas (like sulfur hot spring) ; ④ where there are devices with high frequency (like wireless devices, electric welding devices, or medical equipments); ⑤ special circumstances.

- c. Electric Wiring
 - 1) The installation must be done in accordance with the national wiring regulations.
 - 2) Only the power cord with the rated voltage and exclusive circuit for the air conditioning can be used.
 - 3) Do not pull the power cord by force.
 - 4) The electric installation should be carried out by the professional personnel as instructed by the local laws, regulations and also this manual.
 - 5) The diameter of the power cord should be large enough and once it is damaged it must be replaced by the dedicated one.
 - 6) The earthing should be reliable and the earth wire should be connected to the dedicated device of the building by the professional personnel. Besides, the air switch coupled with the leakage current protection switch must be equipped, which is of enough capacity and of both magnetic and thermal tripping functions in case of the short circuit and overload.

Table 1

Models	Power Supply	Capacity of the Air Switch	Recommended Cord (pieces× sectional area)
36/42K	220-240V~ 50Hz	32A	4mm ² ×3

d. Earthing Requirements

- 1) The air conditioner is classified into the Class I appliances, so its earthing must be reliable.
- 2) The yellow-green line of the air conditioner is the earth line and can not be used for other purpose, cut off or fixed by the tapping screw; otherwise it would cause the hazard of electric shock.
- 3) The reliable earth terminal should be provided and the earth wire can not be connected to any of the following places.
 - ① Running water pipe;
 - ② Coal gas pipe;
 - ③ Sewage pipe;
 - ④ Other places where the professional personnel think unreliable.

GWHD(36)NK3BO

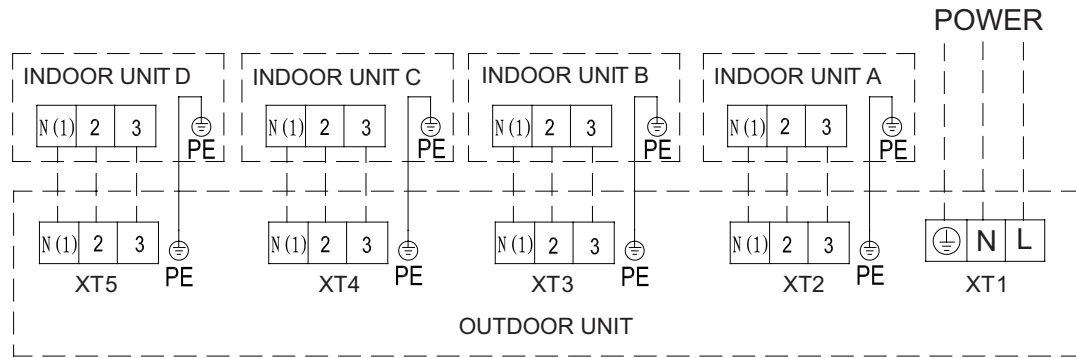

Fig.1

GWHD(42)NK3AO

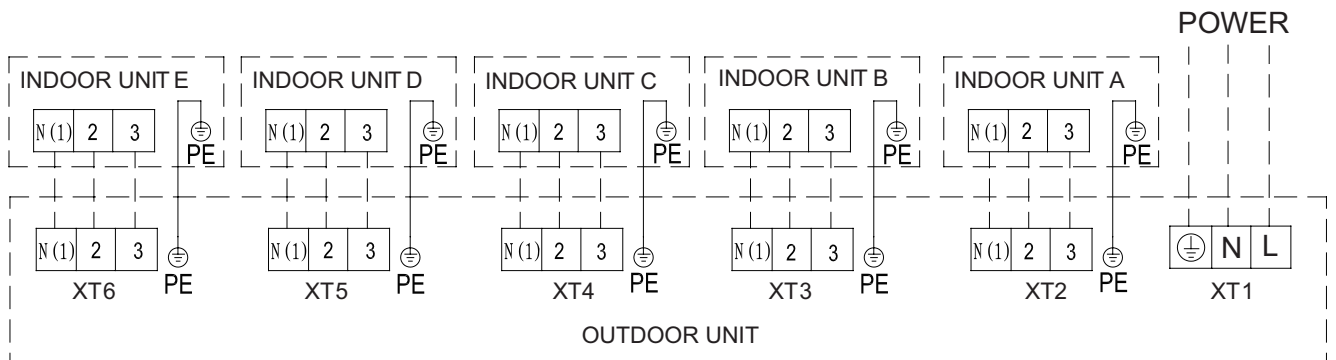

Fig.2

a. Noise Precautions

- 1) The air conditioning unit should be installed where ventilation is in good condition, otherwise the working capability of the unit would be reduced or working noise would be increased.
- 2) The air conditioning unit should be installed on the base frame which is stable and secure uncouth to withstand the weight of the unit; otherwise it would incur vibration and noise.
- 3) During the installation, a consideration should be taken that the produced hot air or noise should not affect neighbors or surroundings.
- 4) Do not stack obstacles near the air outlet of the outdoor unit; otherwise it would reduce the working capability of the unit or increase the working noise.
- 5) In the event of the occurrence of abnormal noise, please contact the sales agent as soon as possible.

b. Accessories for Installation

Refer to the packing list for the accessories of the indoor and outdoor units respectively.

8.5.2 Installation of the Outdoor Unit

a. Precautions for the Installation of the Outdoor Unit

The following rules should be followed when the installation location is being considered so as to let the unit run well enough.

- 1) The discharged air from the outdoor unit won't return back and enough space should be left for maintenance around the unit.
- 2) The installation location should be in good condition so that the unit is able to take in and discharge enough air. Besides, make sure there is no obstacle at the air inlet/outlet of the unit. If there is, remove it.
- 3) The unit must be installed where it is secure enough to support the weight of the unit and capable of reducing to some extent noise and vibration to make sure they do not bother your neighbors.
- 4) The designated lifting hole must be used for lifting the unit and protect the unit carefully during lifting to prevent damaging the metal sheet which would result in rusting in future.
- 5) The unit should be installed where there is as little as direct sunlight.
- 6) The unit must be installed where the rain water and defrosting water can be drained.
- 7) The unit must be installed where the unit won't be covered by the snow and won't be affected by rubbish and oil fog.
- 8) Rubber or spring shock absorbers should be used during the installation of the outdoor unit to meet the noise and vibration requirements.
- 9) The installation dimensions should meet the requirement covered in this manual and the outdoor unit must be fixed securely.
- 10) For the Free Match system, Do not install only one indoor unit for the outdoor unit.
- 11) The installation should be carried out by the professionally skilled personnel.

b. Installation of the Outdoor Unit

- 1) Outline dimension of the outdoor unit.

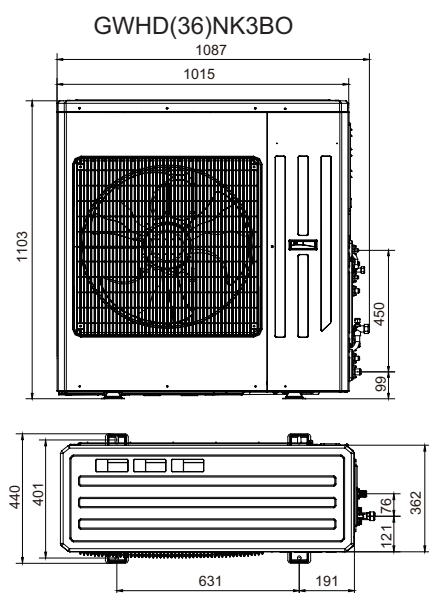

Fig.3

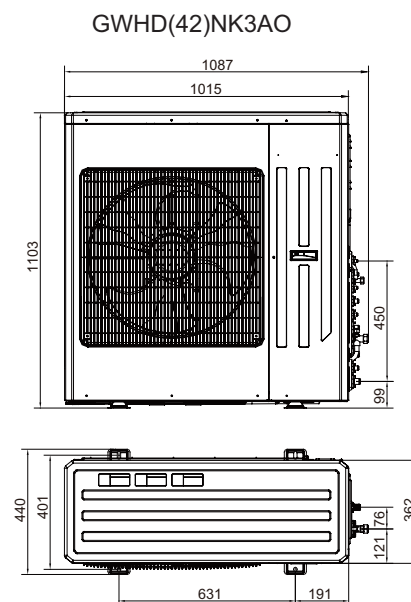

Fig.4

- 2) During the transportation of the outdoor unit, two lifting ropes long enough must be used in four directions and the included angle must be less than 40° prevent the center of unit deviating.
- 3) During the installation, M12 screws should be used to fix the support leg and base frame of the unit.
- 4) The unit should be installed on a concrete base frame with a height of 10cm.
- 5) The installation space of the unit should be as required in Fig.5.

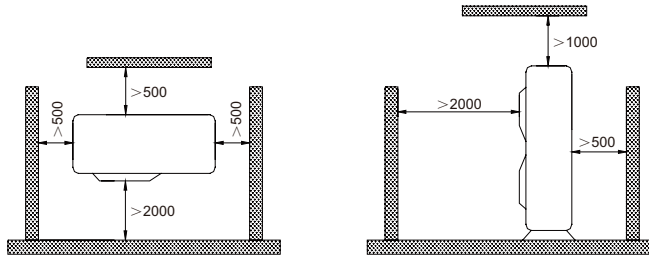

Fig.5

8.5.3 Connection between Indoor and Outdoor Units

a. Wiring of the Power Cord

▲CAUTION!

A breaker must be installed, capable of cutting off the power supply for the whole system.

- 1) Open the side plate.
- 2) Let the power cord go through the rubber ring.
- 3) Connect the power card to the terminals “L”, “N” and also the earthing bolt, and then connect the wiring terminals “N(1),2,3” of the indoor unit to those of the outdoor unit correspondingly.
- 4) Fix the power cord with wire clips.

b. Energy Level and Capacity Code of the Indoor and Outdoor Units

Table 2

	Energy Level	Capacity Code
Indoor Unit	09	25
	12	35
	18	50
	21	60
	24	71
Outdoor Unit	36	100
	42	120

- 1) The outdoor unit with energy level 36 can drive up to four sets of indoor units, while the outdoor unit 42 can drive up to five.
- 2) The sum of the capacity codes of the indoor units should be among 50%-150% of that of the outdoor unit.

c. Allowable Length and Height Fall of the Refrigerant Pipe

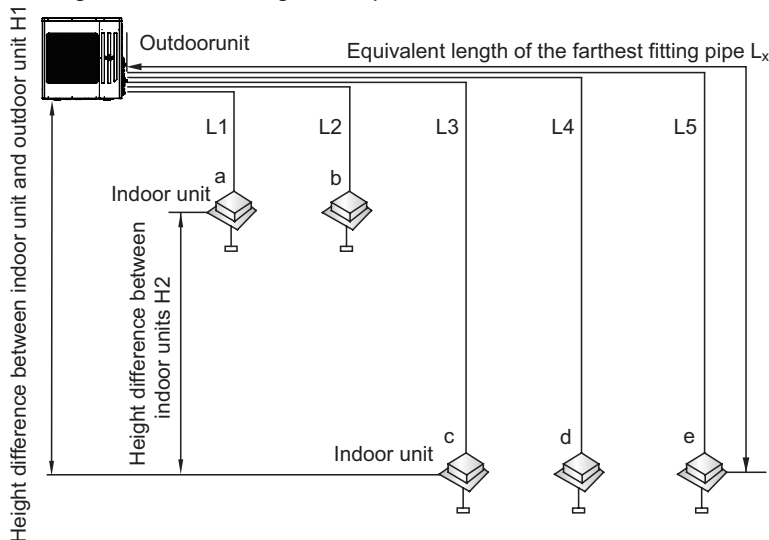

Table 3

		Allowable Length		Refrigerant Pipe	
		36	42	36	42
Total Length(m)		70	80	$L_1+L_2+L_3+L_4$	$L_1+L_2+L_3+L_4+L_5$
Max. Length for Single Unit(m)		20	25	L_x	
Max. installation altitude	Outdoor unit and indoor unit	15	15	H1	
	Indoor unit and indoor unit	7.5	7.5	H2	

Table 4: Dimension of the Refrigerant Pipe of the Indoor Unit unit: mm

Capacity Level of the Indoor Unit	Gas Pipe	Liquid Pipe
09,12	Φ9.52	Φ6.35
18	Φ12.7	Φ6.35
21,24	Φ15.9	Φ9.52

d.Piping between the Indoor and Outdoor Units

- 1) Refer to Fig.6 for the moments of torque for tightening screws.
- 2) Let the flare end of the copper pipe point at the screw and then tighten the screw by hand.
- 3) After that, tighten the screw by the torque wrench unit it clatters (as shown in Fig.6).
- 4) The bending degree of the pipe can not be too small; otherwise it will crack. And please use a pipe tube bender to bend the pipe.
- 5) Wrap the exposed refrigerant pipe and the joints by sponge and then tighten them with the plastic tape.

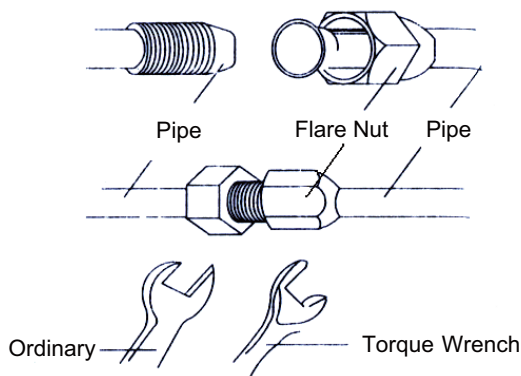
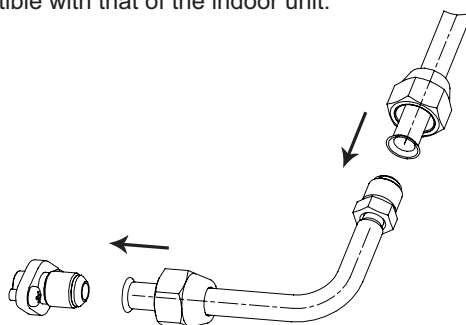

Fig.6

Table 5: Moments of Torque for Tightening Screws

Diameter	Wall Thickness (mm)	Moment of Torque
Φ6.35mm	≥0.5	15-30(N·m)
Φ9.52mm	≥0.71	30-40(N·m)
Φ12.7mm	≥1	45-50(N·m)
Φ15.9mm	≥1	60-65(N·m)

If the specification of the outdoor unit pipe joint does not conform to that of the indoor unit, then the joint specification of the outlet pipe of the indoor unit takes precedence. A reducing nipple shall be installed at the joint of the outdoor unit so as to make the joint of the outdoor unit compatible with that of the indoor unit.



4) Make sure the system has no leakage. When compressor is not working, fill a set amount of R410a refrigerant into the unit through outdoor unit's liquid valve. If the inner tube pressure rises and the set amount of refrigerant can't be filled inside quickly, you can turn on the unit to make it start cooling, then fill the refrigerant inside through outdoor unit's gas valve.

- a. Calculation of the Additional Refrigerant Charging
- 1) Refrigerant Charge in the Outdoor Unit before Shipment

Table 6

Model	GWHD(36)NK3BO	GWHD(42)NK3AO
Refrigerant Charge (kg)	4.2	4.8

Notes:

① The refrigerant charge mentioned in the table above is not included those charged additionally in the indoor unit and the refrigerant pipe.

② The amount of the additional refrigerant charge is dependent on the diameter and length of the liquid refrigerant pipe which is decided by the actual yield installation requirement.

③ Record the additional refrigerant charge for future maintenance.

- 2) Calculation of the Additional Refrigerant Charge

If the total refrigerant pipe length (liquid pipe) is smaller than that listed in the table below, no additional refrigerant will be charged.

Table 7

Model	Total Liquid Pipe Length (a+b+c+d+e)
GWHD(36)NK3BO	≤40m
GWHD(42)NK3AO	≤50m

Additional Refrigerant Charge₂=ΣExtra Liquid Pipe Length×22g/m(liquid pipe 1/4").

Note: if the total refrigerant pipe length is larger than that listed in the table above, the additional refrigerant for the extra length of the pipe needs to be charged as per 22g/m.

- 3) Example : GWHD (42) NK3AO

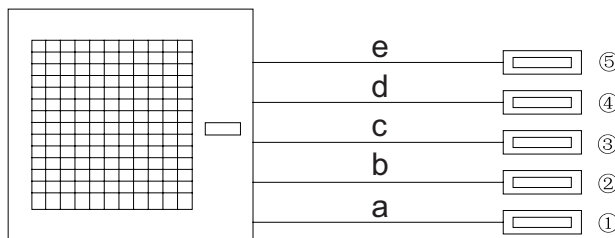

Fig.9

Table 8 Indoor Unit

Serial No.	Model
Indoor Unit ⑤	Ducted Type GFH(09)EA-K3DNA1A/I
Indoor Unit ④	Ducted Type GFH(09)EA-K3DNA1A/I
Indoor Unit ③	Ducted Type GFH(09)EA-K3DNA1A/I
Indoor Unit ②	Ducted Type GFH(09)EA-K3DNA1A/I
Indoor Unit	Ducted Type GFH(18)EA-K3DNA1A/I

Table 9 Liquid Refrigerant Pipe

Serial No.	e	d	c	b	a
Diameter	Φ6.35	Φ6.35	Φ6.35	Φ6.35	Φ9.52
Length	20m	20m	15m	5m	5m

The total length of each liquid refrigerant pipe is: e+d+c+b+a=20+20+15+5+5=65m. Thus, the minimum additional refrigerant charge=(65-50)×0.022=0.33kg (Note: no additional refrigerant is needed for the liquid pipe within 50m).

4) Additional Refrigerant Charge Record

Table 10 Indoor Unit

No.	Indoor Unit Model	Additional Refrigerant Charge(kg)
1		
2		
.....		
N		
Total		

Table 11 Refrigerant Pipe

Diameter	Total Length(m)	Additional Refrigerant Charge(kg)
Φ15.9		
Φ12.7		
Φ9.52		
Φ6.35		
Total		

c. Items to be checked after the Installation

Table 12

Items to be Checked	Possible Errors	Check Results
Has each part and component of the unit been installed securely?	The unit may fall off, vibrate or generate noise.	
Has the gas leakage test been taken?	The cooling (heating) capacity may be poor.	
Is the thermal insulation sufficient?	Dews and water drops may be generated.	
Does the drainage go well?	Dews and water drops may be generated.	
Is the actual power voltage in line with the value marked on the nameplate?	The unit may break down or some components may be burnt out.	
Are the wiring and the piping correct?	The unit may break down or some components may be burnt out.	
Has the unit been earthed reliably?	There may be a danger of electric shock.	
Does the wire meet the regulated requirement?	The unit may break down or the component may be burnt out.	
Is there any obstacle at the air inlet/outlet of the indoor/outdoor unit?	The cooling (heating) capacity may be poor	
Have the length of the refrigerant pipe and the refrigerant charge been recorded?	It may be hard to know the exact refrigerant charge.	

d. Trial Running

1) Check before the Trial Running

- ① Check if the appearance of the unit and the piping system are damaged during the transportation.
- ② Check if the wiring terminals of the electronic component are secure.
- ③ Check if the rotation direction of the fan motor is right.
- ④ Check if all valves in the system are fully opened.

2) Trial Running

- ① The trial running should be carried out by the professionally skilled personnel on the premise that all items listed above are in normal conditions.
- ② Let the unit energized and switch the wired controller or the remoter controller to "ON".
- ③ The fan motor and compressor of the outdoor unit will run automatically in one minute.
- ④ If there is some unusual sound after the compressor is started, turn off the unit for an immediate check.



9. Maintenance

9.1 Precautions before Performing Inspection or Repair

There are high-capacity electrolytic capacitors on the outdoor mainboard. Thus, even the power is cut off, there is high voltage inside the capacitors and it needs more than 20min to reduce the voltage to safety value. Touching the electrolytic capacitor within 20min after cutting the power will cause electric shock. If maintenance is needed, follow the steps below to discharge electricity of electrolytic capacitor after power off.

(1) Open the top cover of outdoor unit and then remove the cover of electric box.

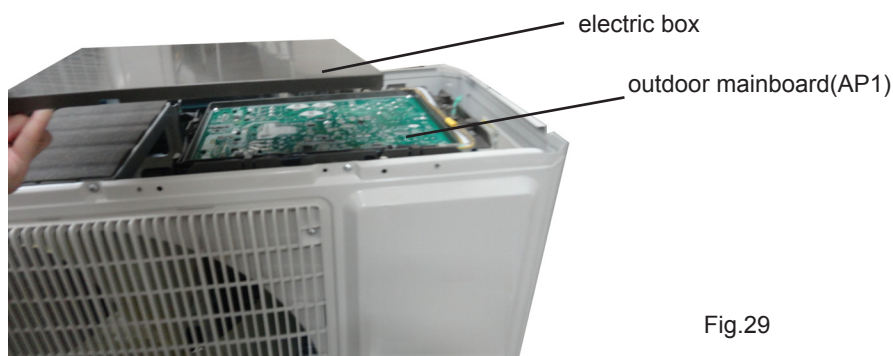

Fig.29

(2) As shown in the fig below, connect the plug of discharge resistance (about 100ohm, 20W) (if there is no discharge resistance, you can use the plug of soldering iron) to point A and B of electrolytic capacitor. There will be sparks when touching them. Press them forcibly for 30s to discharge electricity of electrolytic capacitor.

outdoor mainboard(AP1)

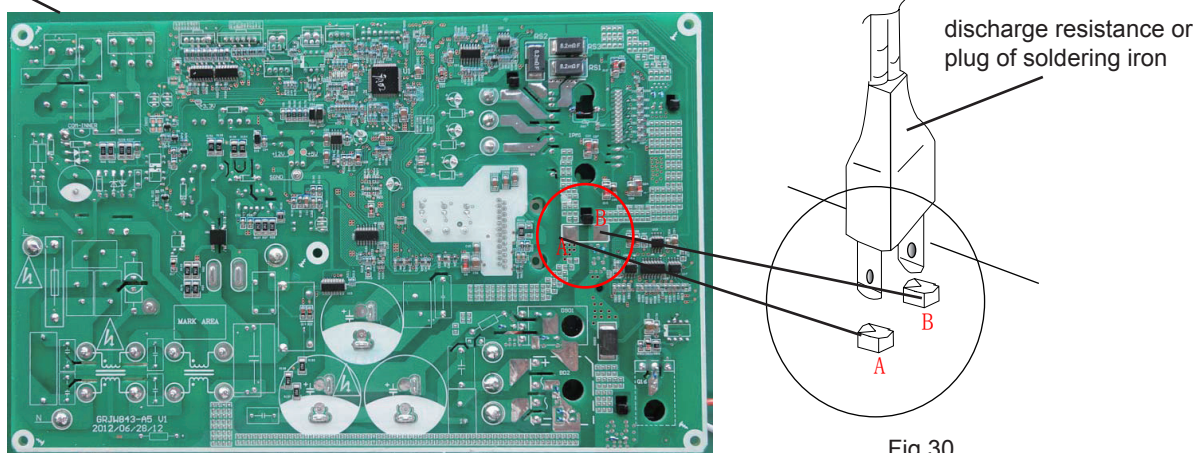

Fig.30

(3) After finish discharging electricity, measure the voltage between point A and B with universal meter to make sure if electricity discharging is completed, in order to prevent electric shock. If the voltage between the two points is below 20V, you can perform maintenance safely.

9.2 Flashing LED of Indoor/Outdoor Unit and Primary Judgement

1. Requirement of malfunction display

When several malfunctions happen at the same time, malfunction codes will be displayed circularly.

2. Malfunction display method

- (1) Hardware malfunction: it will be displayed immediately, please refer to "Malfunction status sheet";
- (2) Operation status: it will be displayed immediately, please refer to "Malfunction status sheet";
- (3) Other malfunction: It will be displayed after the compressor has been stopped for 200s, please refer to "Malfunction status sheet".

(Note: when the compressor starts up again, malfunction display waiting time (200s) will be cleared.)

3. Malfunction display control

Indoor unit displays malfunction code as shown in the sheet below. ODU communication light will be off for 1s and then blink for 1s circularly.

4. Viewing malfunction code through remote controller

Enter viewing malfunction code: pressing light button for 6 times within 3S to view malfunction code;

Exit viewing malfunction code: pressing light button for 6 times within 3S or after the malfunction code is displayed for 5min.

Malfunction status sheet		
Malfunction name	Malfunction type	Nixie tube
Zero cross detection circuit malfunction	Hardware malfunction	U8
Malfunction protection of jumper cap	Hardware malfunction	C5
Feedback of without IDU motor	Hardware malfunction	H6
Indoor ambient temperature sensor is open/short circuited	Hardware malfunction	F1
Indoor evaporator temperature sensor is open/short circuited	Hardware malfunction	F2
Liquid valve temperature sensor is open/short circuited	Hardware malfunction	b5
Gas valve temperature sensor is open/short circuited	Hardware malfunction	b7
Modular temperature sensor is open/short circuited	Hardware malfunction	P7
Outdoor ambient temperature sensor is open/short circuited	Hardware malfunction	F4
Outdoor condenser inlet pipe temperature sensor is open/short circuited (commercial)	Hardware malfunction	A5
Outdoor condenser middle pipe temperature sensor is open/short circuited	Hardware malfunction	F4
Outdoor condenser outlet pipe temperature sensor is open/short circuited (commercial)	Hardware malfunction	A7
Outdoor discharge temperature sensor is open/short circuited	Hardware malfunction	F5
Communication malfunction	Hardware malfunction	E6
Malfunction of phase current detection circuit for compressor	Hardware malfunction	U1
Compressor demagnetization protection	Viewing malfunction code through remote controller within 200s; displayed directly on nixietube after 200s	HE
Malfunction of voltage dropping for DC bus-bar		U3
Module high temperature protection		P8
Refrigerant lacking or blockage protection of system (not available for residential ODU)		F0
Charging malfunction of capacitor	Hardware malfunction	PU
High pressure protection of system	Hardware malfunction	E1
Low pressure protection of system (reserved)	Hardware malfunction	E3

Compressor overload protection	Viewing malfunction code through remote controller within 200s; displayed directly on nixietube after 200s	H3
Indoor unit and outdoor unit do not match	Hardware malfunction	LP
Malfunction of memory chip	Hardware malfunction	EE
Wrong connection of communication wire or malfunction of electronic expansion valve	Hardware malfunction	dn
Malfunction of complete units current detection	Hardware malfunction	U5
Malfunction protection of outdoor fan 1	Hardware malfunction	L3
Detection status of wrong connection of communication wire or malfunction of electronic expansion valve	Operation status	dd
Mode conflict	Operation status	E7
Refrigerant recycling mode	Operation status	Fo
X-fan	Operation status	AL
Defrosting or oil return in heating mode	Operation status	H1
Start failure of compressor	Viewing malfunction code through remote controller within 200s; displayed directly on nixietube after 200s	Lc
High discharge temperature protection of compressor		E4
Overload protection		E8
Whole unit overcurrent protection		E5
Compressor phase current protection		P5
Compressor desynchronizing		H7
Compressor phase-lacking/phase-inverse protection		Ld
IPM modular protection		H5
DC bus-bar low voltage protection		PL
DC bus-bar high voltage protection		PH
PFC protection		HC
The four-way valve is abnormal		U7

9.3 Malfunction Checking and Elimination

Note: discharge the position in below pictures with discharge resistance after open the top cover and check if the voltage is below 20V with universal meter, then begin to check.

14/18K:

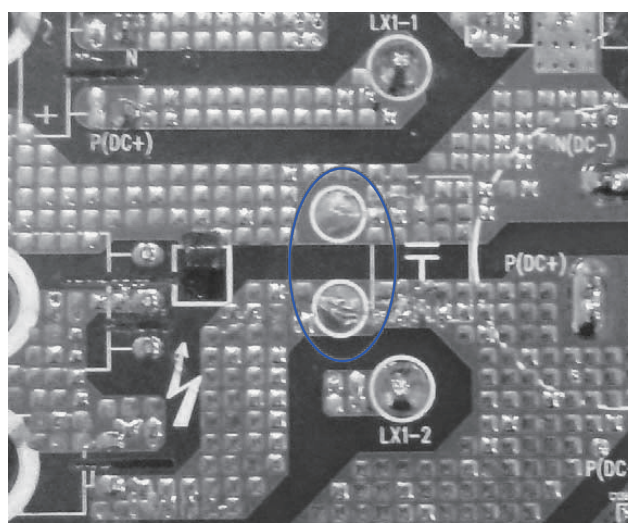

24/28K:

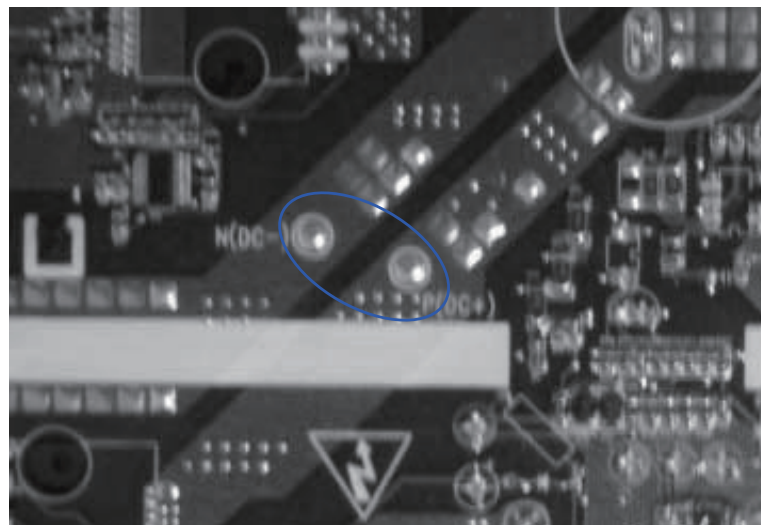

1 IPM protection malfunction:

Main checking point:

- If the input voltage of the unit is within normal range?
- If the connection wire of compressor is connected well? Is it loose? If the connection sequence is correct?

- If the resistance of compressor coil is normal? If the isolation of compressor coil with copper pipe is good?
- If the unit is overloaded? If the heat radiation of the unit is good?
- If the refrigerant charge is suitable?

Flow chart:

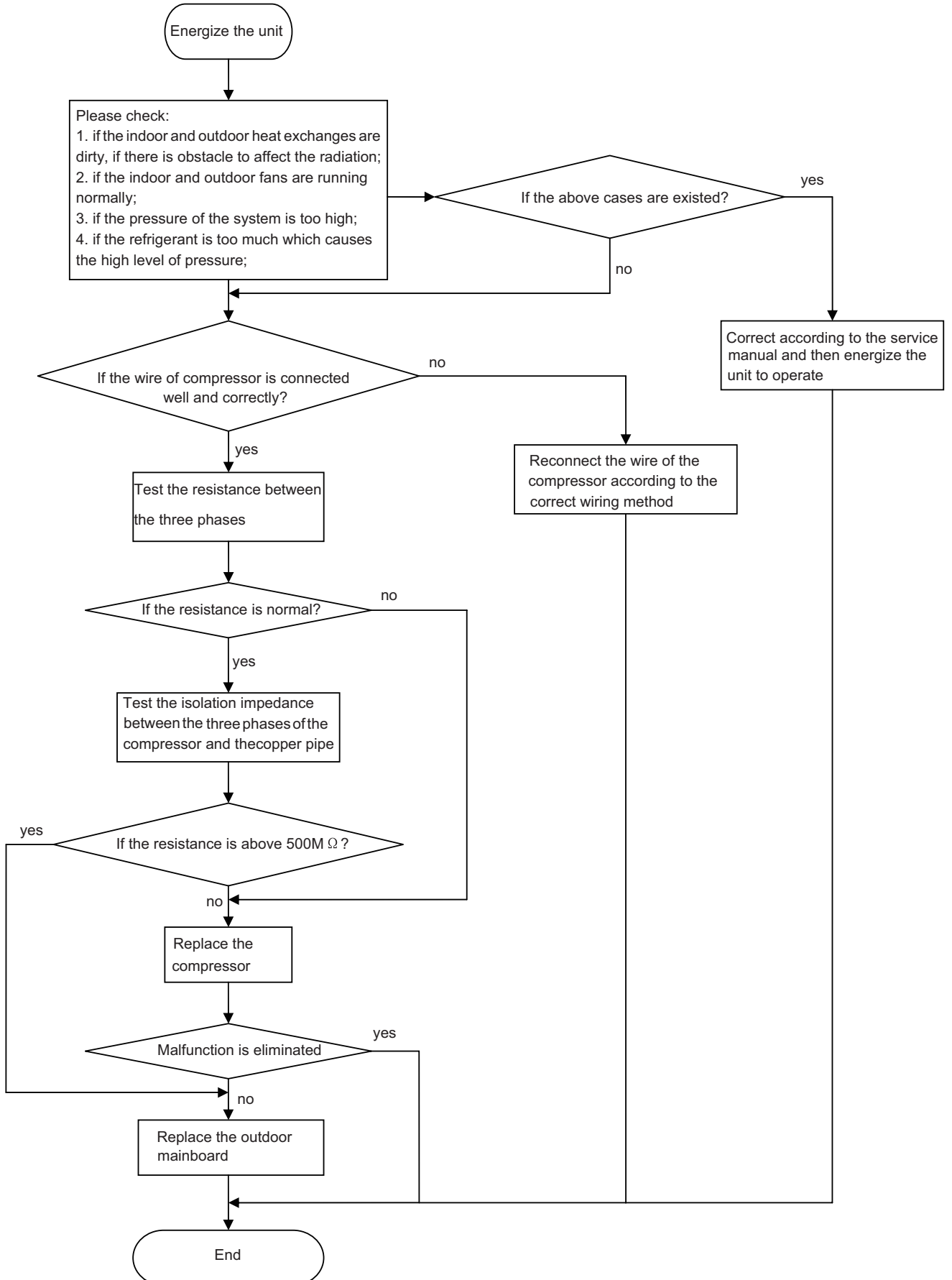

2. PFC protection malfunction, capacity charging malfunction

Main checking points:

- If the wiring of the induction is connected well and if the induction is broken;
- If the mainboard is broken;

Flow chart:

For 18K

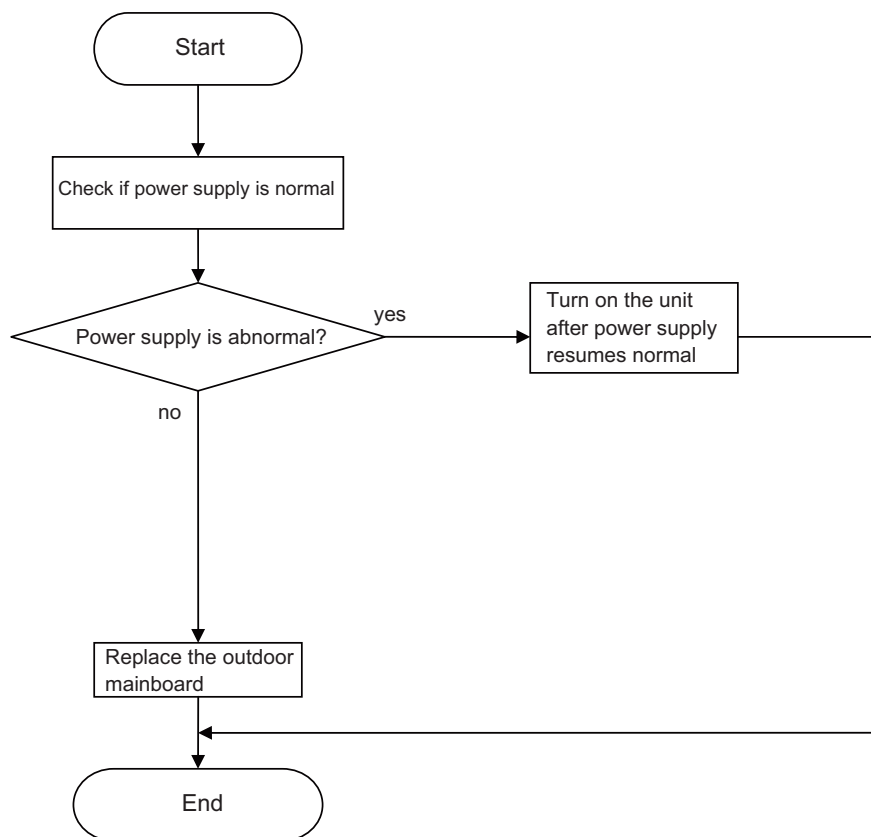

For 24/28K

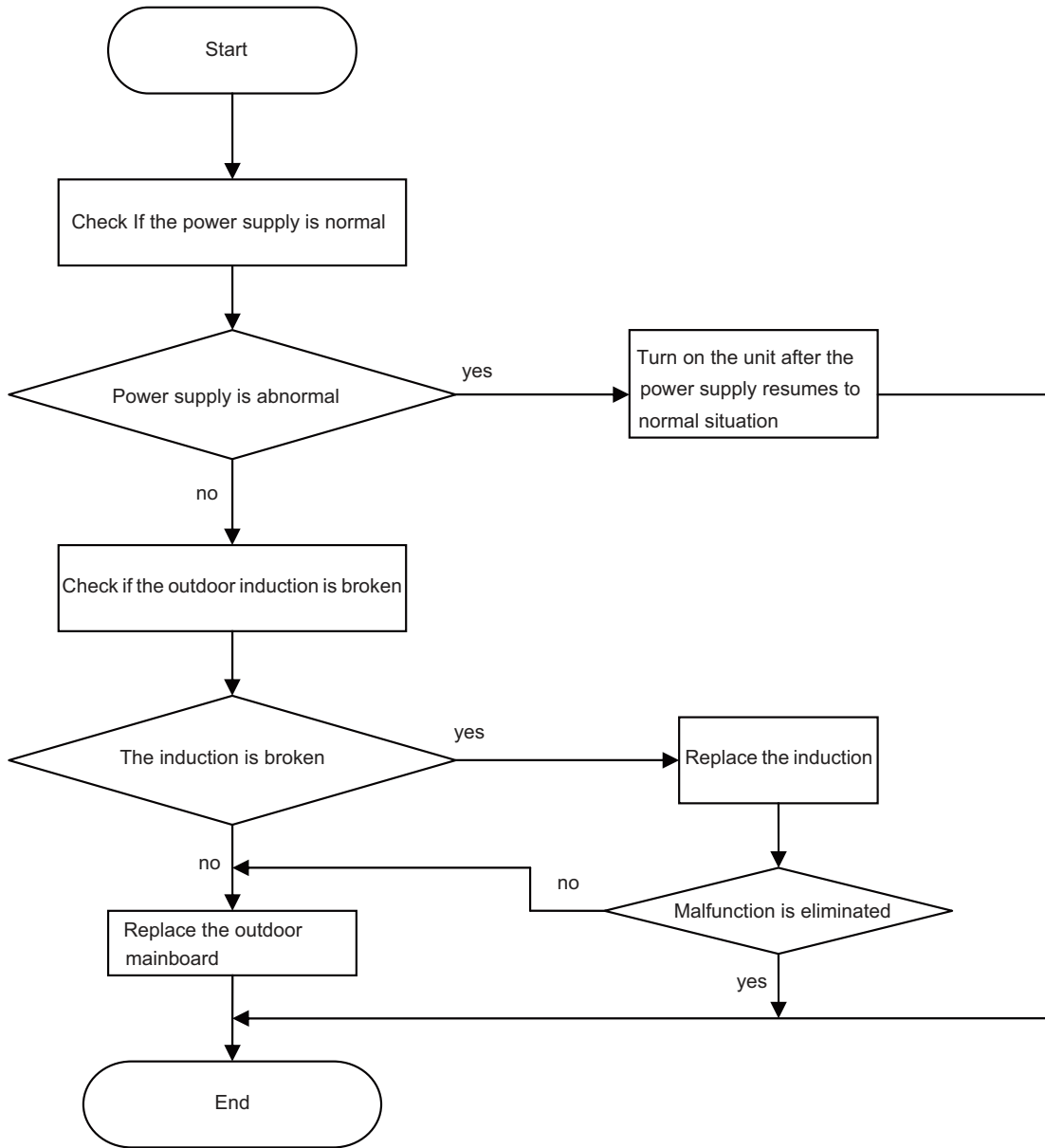

3. Compressor desynchronizing malfunction

Main checking points:

- If the pressure of the system is too high;
- If the electric expansion valve is working normally or it is broken;
- If the radiation of the unit is good;

Flow chart:

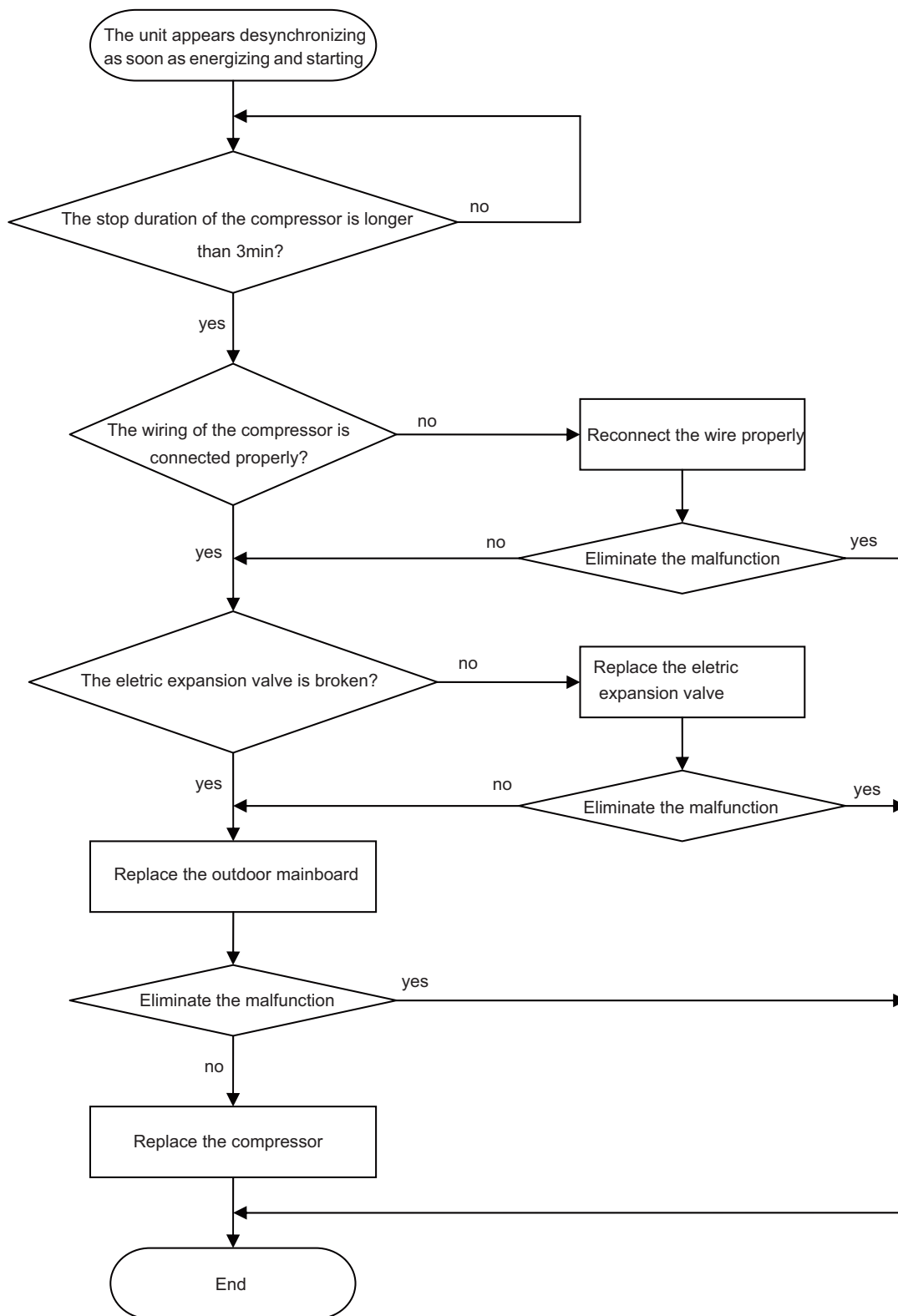

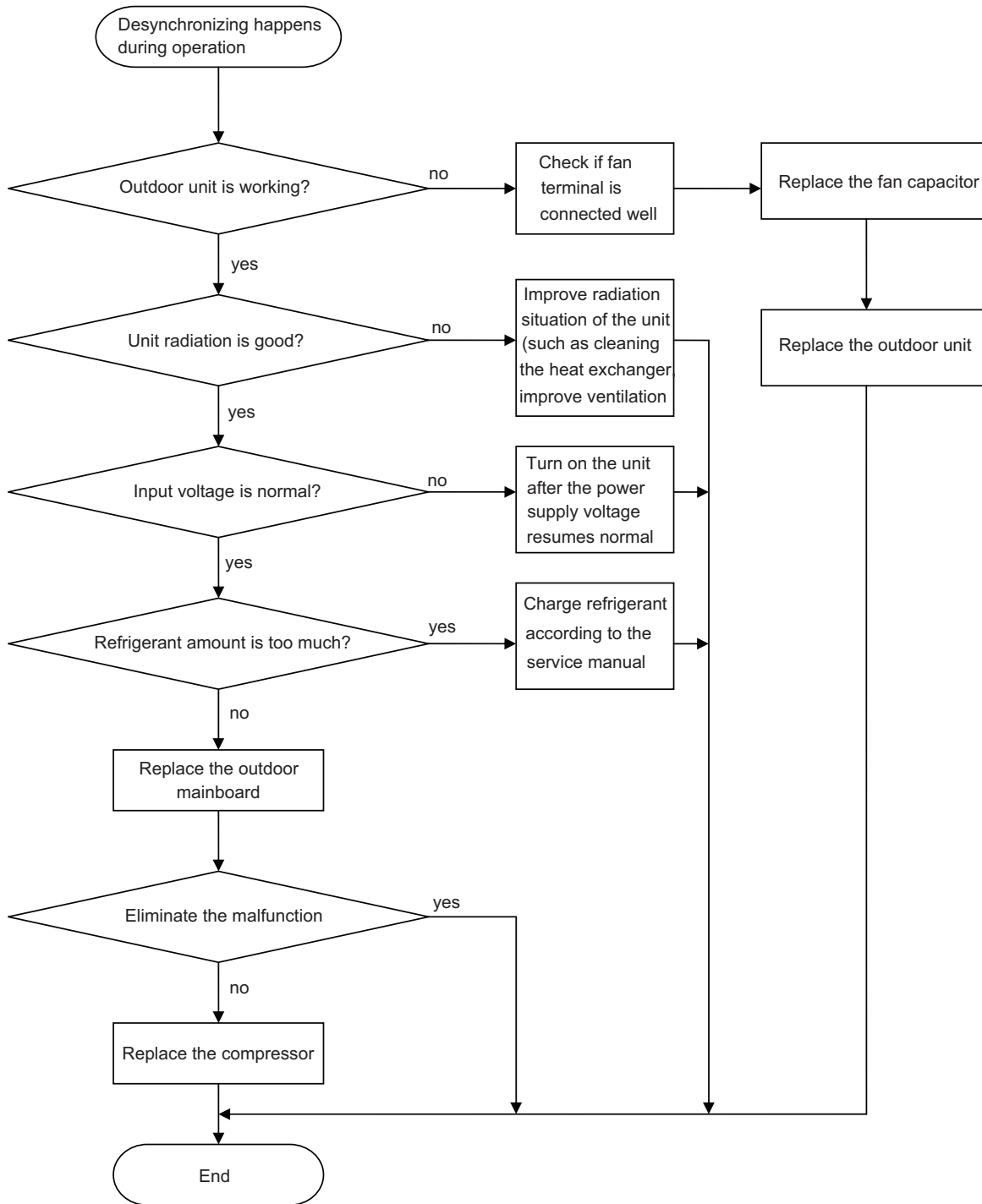

4. Compressor overload, discharge protectionmalfunction

Main checking points:

- If the eletric expansion valve is connected well or it is broken;
- If there is refrigerant leakage;
- If the overload protector is broken;

Flow chart:

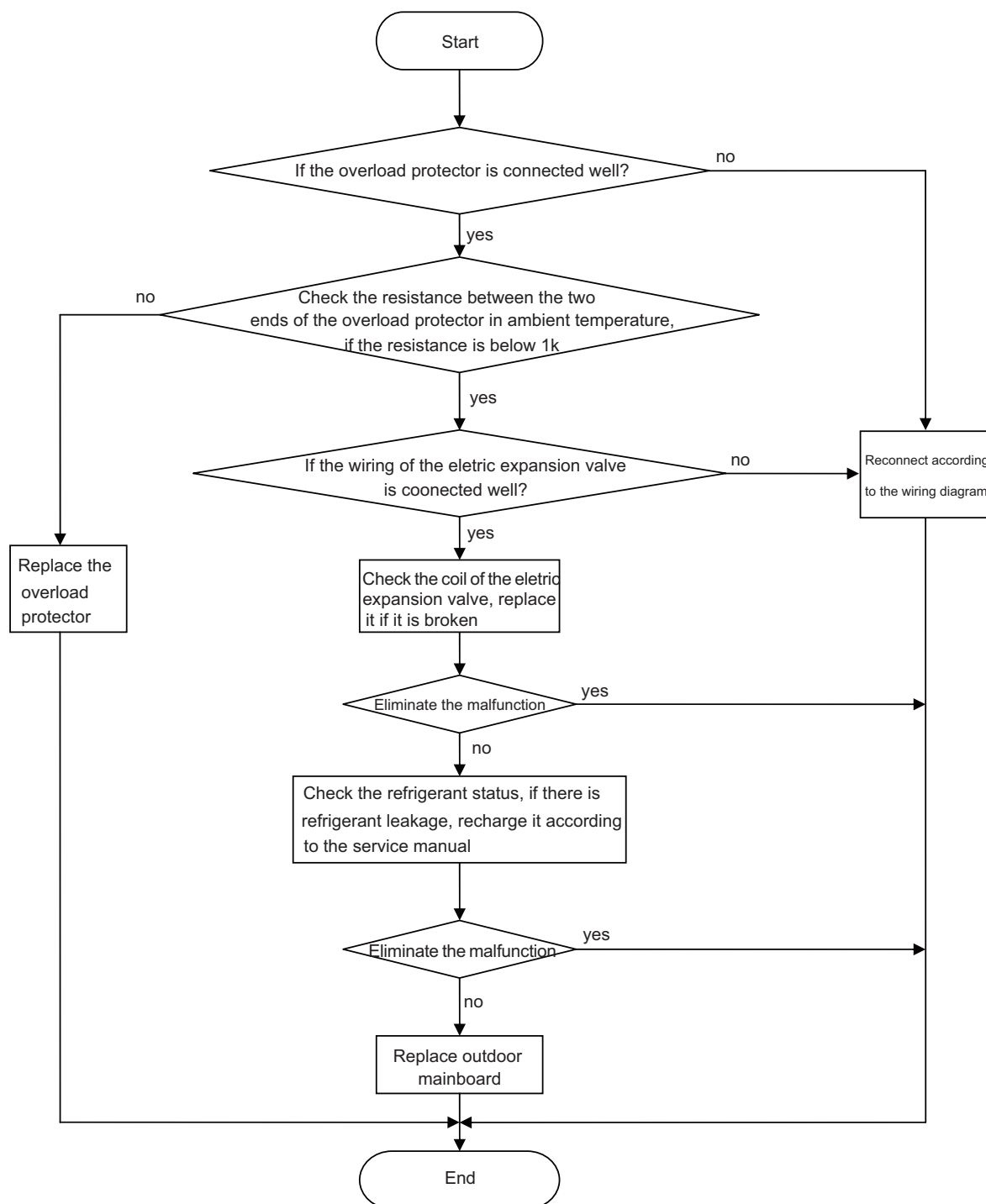

Note: the detection method of the coil of the eletric expansion valve: there is five pieces of coil of the eletric expansion valve, the resistance of one of them (the leftmost or the rightmost one) is almost the same as the resistance of other terminal (within 100 Ω). Judge the condition of the electronic expansion valve through detecting these resistance.

5. Start failure malfunction

Main checking points:

- If the connection wire of the compressor is connected properly;
- If the stop duration of the compressor is sufficient;
- If the compressor is broken;
- If the refrigerant charging amount is too much;

Flow chart:

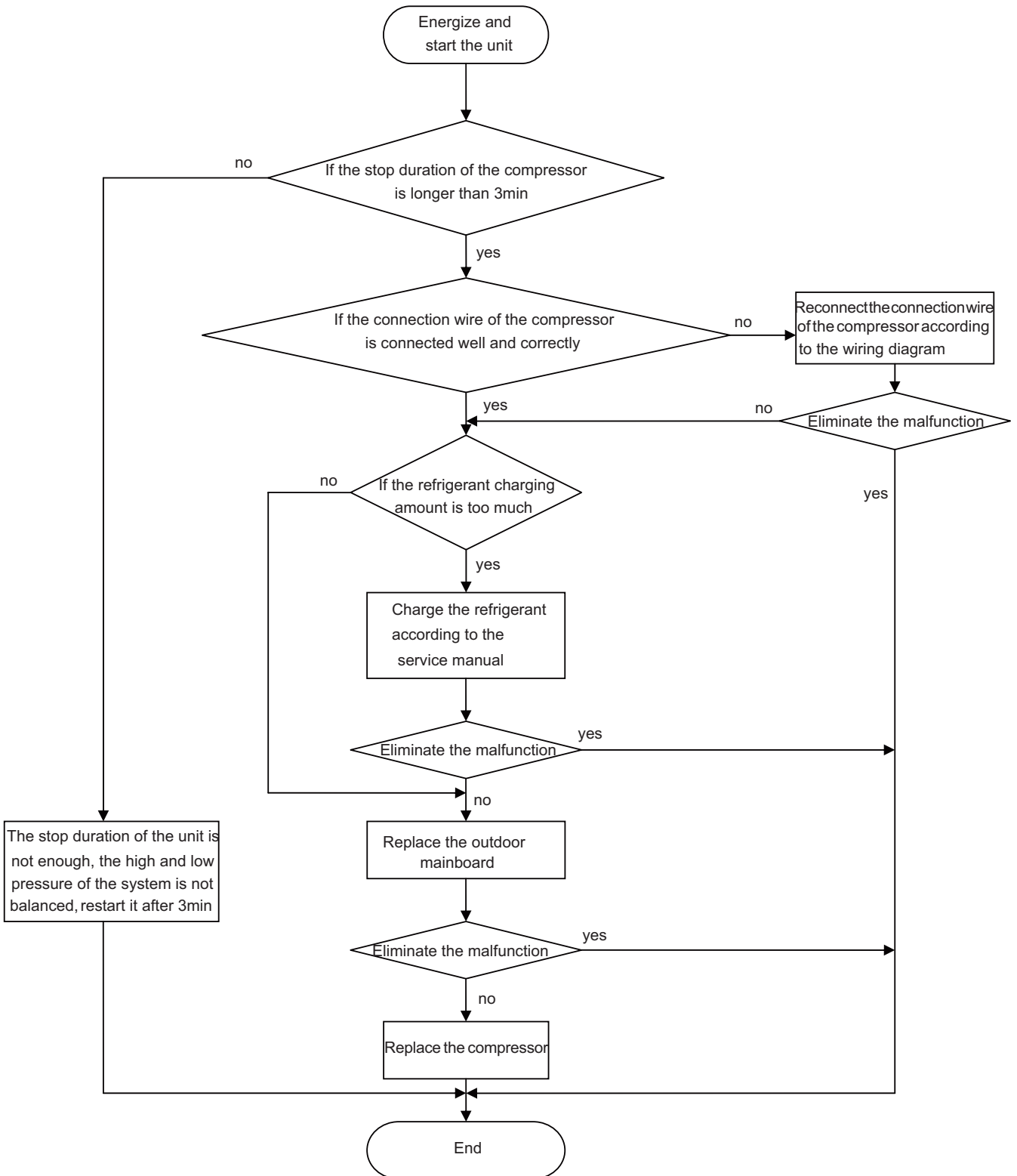

6. Temperature sensor malfunction

Main checking points:

- If the temperature sensor is damaged or broken
- If the terminal of the temperature sensor is loosened or not connected;
- If the mainboard is broken;

Flow chart:

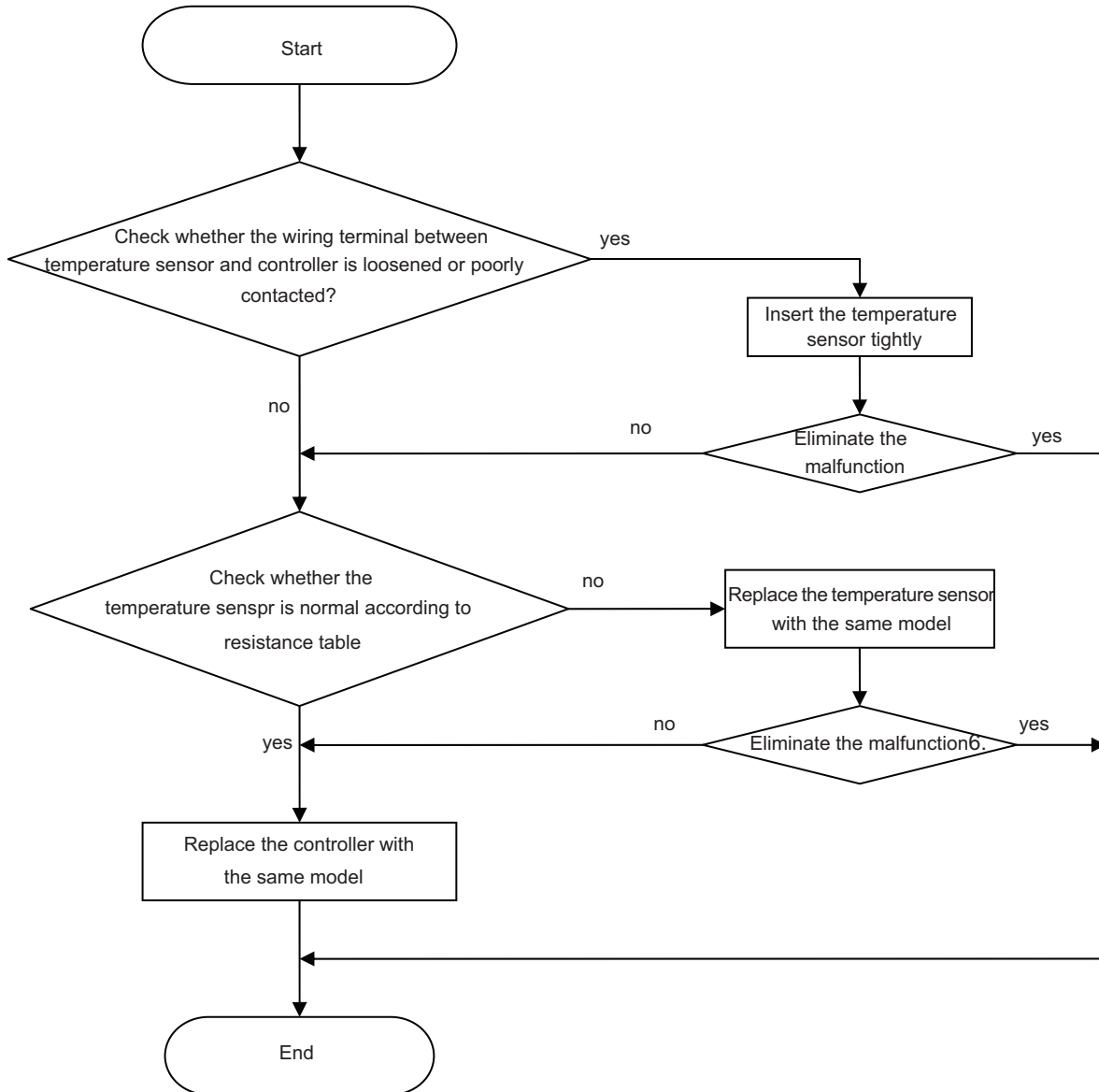

8. Communication malfunction

Main checking points:

- If the connection wire between the indoor unit and outdoor unit is connected well, if the wires inside the unit is connected well;
- If the indoor mainboard or outdoor main board is broken;

Flow chart:

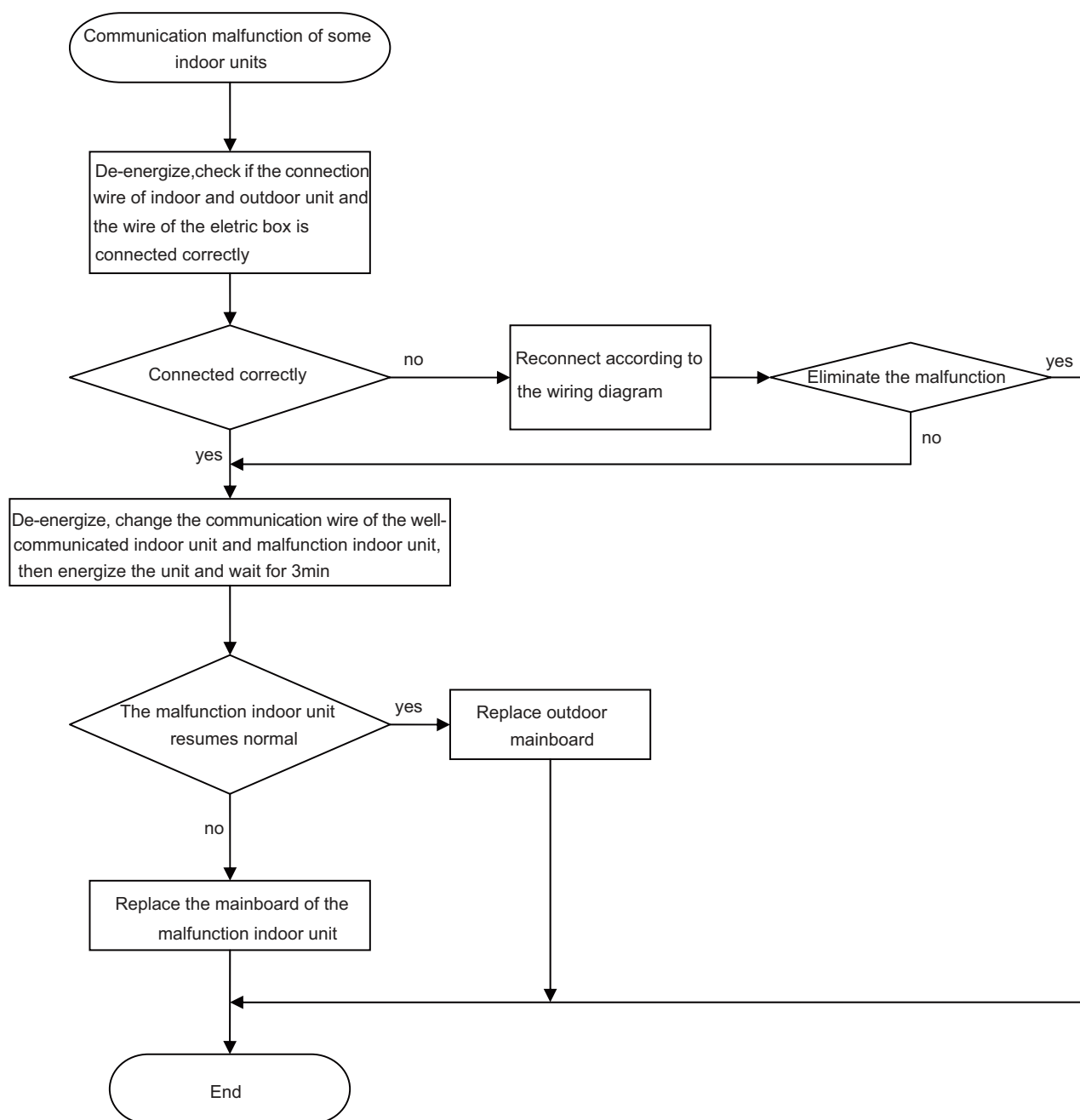

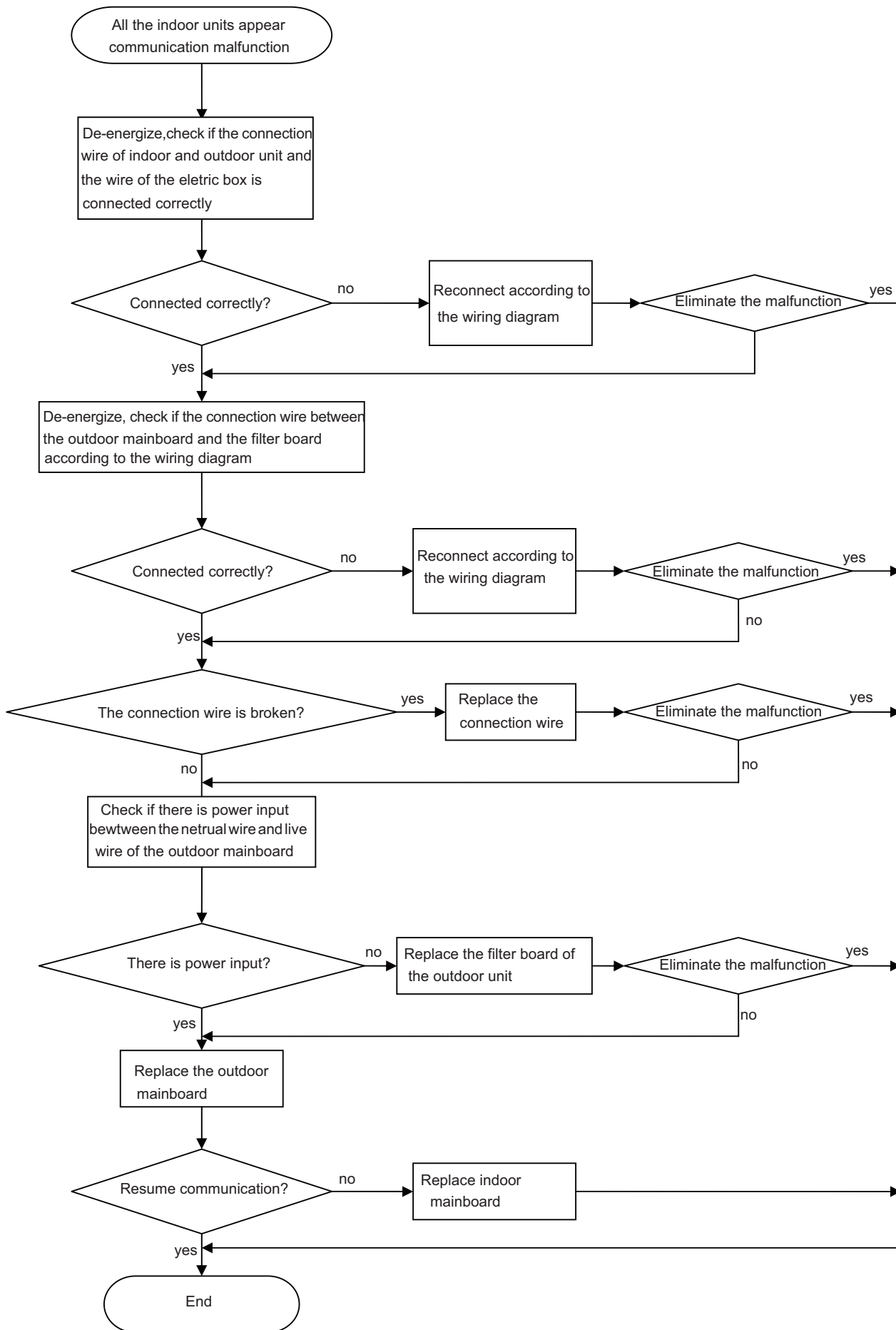

9. Anti-high temperature and overload malfunction

Main checking points:

- If the outdoor ambient temperature is within the normal range;
- If the indoor fan and outdoor fan are running normally;
- If the indoor and outdoor radiation environment is good;

Flow chart:

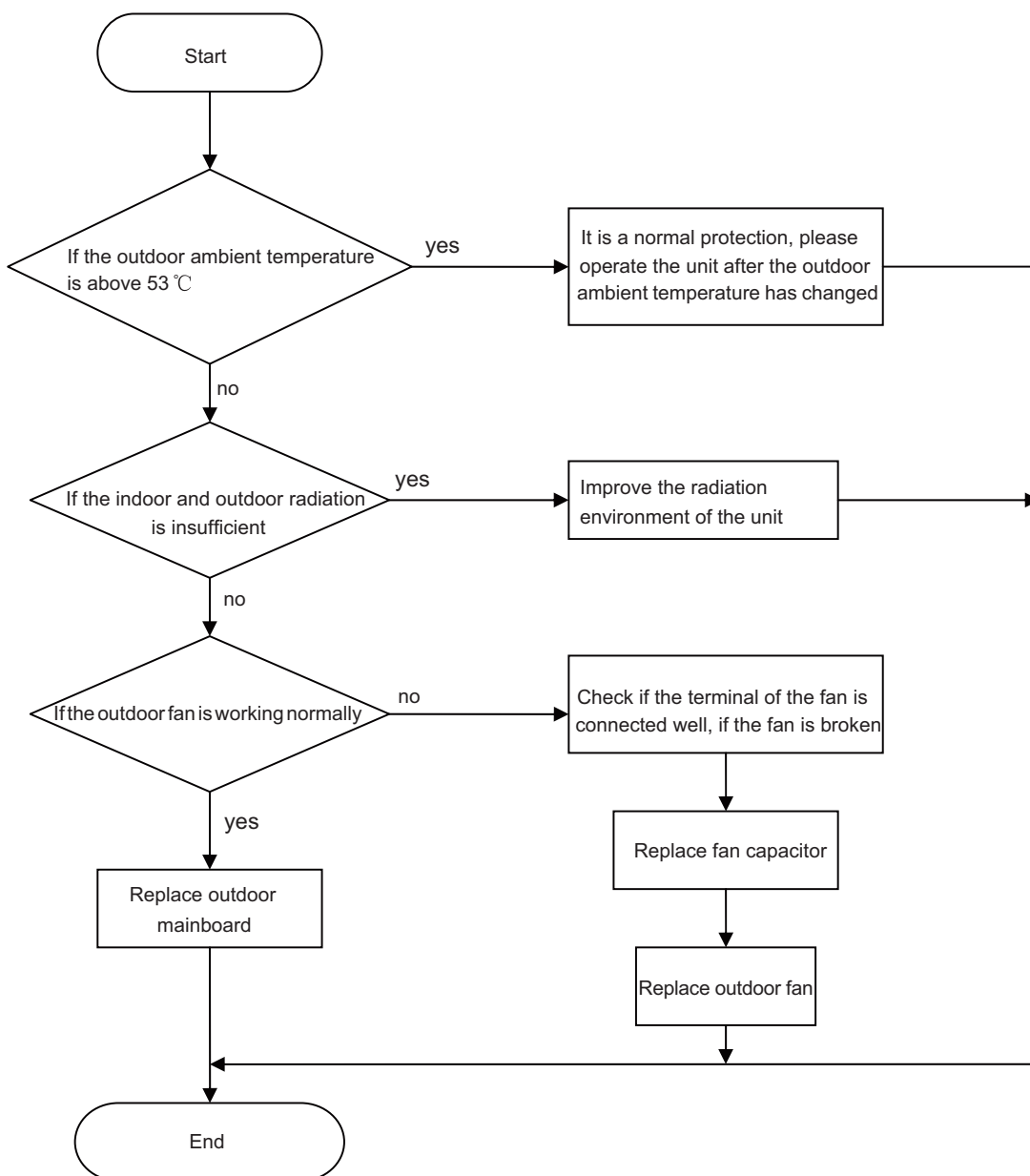

Models:36K and 42K

1. Trouble Table

⚠ WARNING!

a. In the event of abnormal conditions (like, stinky smell), please shut off the main power supply immediately and then contact the GREE appointed service center; otherwise the continuous abnormal running would damage the air conditioning unit and also would cause electric shock or fire hazard etc.

b. Do not repair the air conditioning personally but instead contact the professionally skilled personnel at the GREE appointed service center, as the incorrect repair would cause electric shock or fire hazard etc.

1.1 Check before Contacting Service Center

Please check the following items before contacting the maintenance serviceman.

Conditions	Causes	Corrective Actions
The unit does not run	Broken fuse or opened breaker	Change the fuse or close the breaker
	Power off	Restart the unit when power on
	Loosened power supply plug.	Plug the power supply properly.
	Insufficient batteries voltage of the remote controller	Change new batteries
	Remoter controller out of the control scope	Keep the control distance within 8 meters.
The unit stops soon after it starts	Clogged inlet/outlet of the indoor/outdoor unit	Clear the obstacle
Cooling/Heating is abnormal	Clogged inlet/outlet of the indoor/outdoor unit	Clear the obstacle
	Improperly set temperature	Adjust the setting of the remote or wired controller.
	Too low set fan speed	Adjust the setting of the remote or wired controller.
	Improper airflow direction	Adjust the setting of the remote or wired controller.
	Opened door and window	Close the door and window
	Direct sunlight	Hang a curtain or blinds over the window.
	Too much people in the room	
	Too much heat sources in the room	Reduce the heat sources
	Dirty filter screen	Clean the filter screen

Table 1

Note: If the air conditioner still runs abnormally after the above check and handling, please contact the maintenance serviceman at the local appointed service center and also give a description of the error occurred as well as the model of the unit

1.2 Problem Handling

The conditions listed below are not classified into errors.

Conditions	Causes	
The unit does not run	When restart the unit soon after it is stopped.	The overload protection switch of the unit let the startup delayed for three minutes.
	As soon as power is on.	The unit will stand by for approximate one minute.
The unit blows out mist	When the cooling operation starts.	The hi-humidity air indoor is cooled quickly.
The unit generates noise	The unit "clatters" as soon as it starts running.	It is the sound generated during the initialization of the electronic expansion valve.
	The unit "swishes" during the cooling operation.	It is the sound when the refrigerant gas runs inside the unit.
	The unit "swishes" when it is started or stopped.	It is the sound when the refrigerant gas stops running.
	The unit "swishes" when it is in and after the running.	It is the sound when the draining system is operating.
The unit blows out dust.	When the unit restarts after it is not used for a long time.	The dust inside the unit is blown out again.
The unit emits odors.	When the unit is running.	The odors absorbed in are blown out again.

Table 2



1.3 Error Description

If some error occurs when the unit is running, the error code will be displayed on the wired controller and the main board  of the outdoor unit. See the table below for more details about the meaning of each error.

Error Item	Outdoor Unit 88 Display	Indicating LED Flashing Times			88 Display	Wired Controller Display	Error Type
		Running LED	Cooling LED	Heating LED			
High Pressure Protection	E1	Flash once	/	/	E1	E1	Outdoor
Shutdown for Whole Unit Anti-Freeze Protection	E2	Flash twice	/	/	E2	E2	System Error
Low Pressure Protection	E3	Flash 3 times	/	/	E3	E3	Outdoor
High Discharge Temp Protection	E4	Flash 4 times	/	/	E4	E4	Outdoor
Communication Error	E6	Flash 6 times	/	/	E6	E6	Outdoor & Indoor
Indoor Unit Water Full Error	E9	Flash 9 times	/	/	E9	E9	Indoor
Refrigerant Recovery Mode	Fo	Quick Flashing	Quick Flashing	/	Fo	Fo	Special Mode
Outdoor Ambient Temp Sensor Error	F3	/	Flash 3 times	/	F3	F3	Outdoor
Outdoor Mid-Coil Temp Sensor Error	F4	/	Flash 4 times	/	F4	F4	Outdoor
Outdoor Discharge Air Temp Sensor Error	F5	/	Flash 5 times	/	F5	F5	Outdoor
Oil Return for Cooling	F7	/	/	/	/	/	Special Mode
Forced Defrosting	H1	Quick Flashing	/	/	H1	H1	Special Mode
Oil Return for Heating or Defrosting	H1	/	/	Flash once	H1		Special Mode
Compressor Overheat Protection	H3	/	/	Flash 3 times	H3	H3	Drive Error
IPM Protection	H5	/	/	Flash 5 times	H5	H5	Drive Error
Motor Desynchronizing	H7	/	/	Flash 7 times	H7	H7	Drive Error
PFC Error	Hc	/	/	Flash 6 times	Hc	Hc	Drive Error
Startup Failure	Lc	/	/	Flash 11 times	Lc	Lc	Drive Error
DC Fan motor Error	LA	/	/	/	/	/	Outdoor
No indoor fan motor	H6	Flash 11 times	/	/	/	/	Indoor
Compressor phase circuit detection error	U1	/	/	Flash 12 times	/	/	Outdoor
DC link voltage drop error	U3	/	/	Flash 20 times	/	/	Outdoor
Zero detection circuit error	U8	Flash 17 times	/	/	/	/	Outdoor
Phase Loss	Ld	Flash 3 times	Flash 3 times	Flash 3 times	Ld	Ld	Drive Error
Compressor Stalling	LE	Flash 3 times	Flash 3 times	Flash 3 times	LE	LE	Drive Error
Over-Speed	LF	Flash 3 times	Flash 3 times	Flash 3 times	LF	LF	Drive Error
IPM Reset	P0	Flash 3 times	Flash 3 times	Flash 3 times	P0	P0	Drive Error
Compressor Current Protection	P5	/	/	Flash 15 times	P5	P5	Drive Error
Communication Error between the Inverter Drive and the Main Controller	P6	Flash 16 times	/	/	P6	P6	Drive Error
Radiator Temp Sensor Error	P7	/	/	Flash 18 times	P7	P7	Drive Error
Radiator Overheat Protection	P8	/	/	Flash 19 times	P8	P8	Drive Error

Table 3

AC Contactor Protection	P9	Flash 3 times	Flash 3 times	Flash 3 times	P9	P9	Drive Error
Current Sensor Error	Pc	/	/	Flash 12 times		U1	Drive Error
Sensor Connection Protection	Pd	Flash 3 times	Flash 3 times	Flash 3 times	Pd	Pd	Drive Error
Over Voltage Protection	PH	/	Flash 11 times	/	PH	PH	Drive Error
Low Voltage Protection	PL	/	/	Flash 21 times	PL	PL	Drive Error
Temp Drift Protection	PE	Flash 3 times	Flash 3 times	Flash 3 times	PE	PE	Drive Error
Drive Board Ambient Temp Sensor Error	PF	Flash 3 times	Flash 3 times	Flash 3 times	PF	PF	Drive Error
AC Current Protection	PA	Flash 5 times	/	/	E5	E5	Drive Error
Charging Circuit Error	PU	/	/	Flash 17 times	PU	PU	Drive Error
AC Input Voltage Anomaly	PP	Flash 3 times	Flash 3 times	Flash 3 times	PP	PP	Drive Error
Unit communication error	See Table 5	Flash 6 times	/	/	E6	E6	Indoor
Unit n indoor pipe midway temperature sensor error	See Table 5	/	Flash twice	/	E2	E2	Indoor
Indoor Evaporator Temp Sensor Short/Open-Circuit	See Table 5	/	Flash twice	/	F2	F2	Indoor
(Air Valve) Unit n indoor unit pipe outlet temperature sensor error	See Table 5	/	Flash 22 times	/	b7	b7	Indoor
(Liquid Valve) Unit n indoor pipe inlet temperature sensor error	See Table 5	/	Flash 19 times	/	b5	b5	Indoor
Unit n mode conflict	See Table 5	/	Flash once	/	F1	F1	Indoor
Mode Conflict	See Table 5	Flash 7 times	/	/	E7	E7	Indoor

The error codes for wall mounted type unit are shown in the following table):

Error Item	Outdoor Unit 88 Display	Indicating LED Flashing Times			88 Display	Wired Controller Display	Error Type
		Running LED	Cooling LED	Heating LED			
High Pressure Protection	E1	Flash once	/	/	E1	E1	Outdoor
Shutdown for Whole Unit Anti-Freeze Protection	E2	Flash twice	/	/	E2	E2	System Error
Low Pressure Protection	E3	Flash 3 times	/	/	E3	E3	Outdoor

High Discharge Temp Protection	E4	Flash 4 times	/	/	E4	E4	Outdoor
Communication Error	E6	Flash 6 times	/	/	E6	E6	Outdoor & Indoor
Indoor Unit Water Full Error	E9	Flash 9 times	/	/	E9	E9	Indoor
Refrigerant Recovery Mode	Fo	Flash once	Flash once	/	Fo	Fo	Special Mode
Outdoor Ambient Temp Sensor Error	F3	/	Flash 3 times	/	F3	F3	Outdoor
Outdoor Mid-Coil Temp Sensor Error	F4	/	Flash 4 times	/	F4	F4	Outdoor
Outdoor Discharge Air Temp Sensor Error	F5	/	Flash 5 times	/	F5	F5	Outdoor
Oil Return for Cooling	F7	/	Flash 7 times	/	/	/	Special Mode
Forced Defrosting	H1	Quick Flashing	/	/	H1	H1	Special Mode
Oil Return for Heating or Defrosting	H1	/	/	Flash once	H1		Special Mode
Compressor Overheat Protection	H3	/	/	Flash 3 times	H3	H3	Drive Error
IPM Protection	H5	/	/	Flash 5 times	H5	H5	Drive Error
Motor Desynchronizing	H7	/	/	Flash 7 times	H7	H7	Drive Error
PFC Error	Hc	/	/	Flash 6 times	Hc	Hc	Drive Error
Startup Failure	Lc	/	/	Flash 11 times	Lc	Lc	Drive Error
DC Fan motor Error	LA	Flash 24 times	/	/	LA	LA	Outdoor
Phase Loss	Ld	/	/	/	Ld	Ld	Drive Error
Compressor Stalling	LE	/	/	/	LE	LE	Drive Error
Over-Speed	LF	/	/	/	LF	LF	Drive Error
IPM Reset	P0	/	/	/	P0	P0	Drive Error
Compressor Current Protection	P5	/	/	Flash 15 times	P5	P5	Drive Error
Communication Error between the Inverter Drive and the Main Controller	P6	Flash 16 times	/	/	P6	P6	Drive Error
Radiator Temp Sensor Error	P7	/	/	Flash 18 times	P7	P7	Drive Error
Radiator Overheat Protection	P8	/	/	Flash 19 times	P8	P8	Drive Error
AC Contactor Protection	P9	/	/	/	P9	P9	Drive Error
Sensor Connection Protection	Pd	/	/	/	Pd	Pd	Drive Error
Low Voltage Protection	PL	/	/	Flash 21 times	PL	PL	Drive Error

Table 4

Temp Drift Protection	PE	/	/	/	PE	PE	Drive Error
Drive Board Ambient Temp Sensor Error	PF	/	/	/	PF	PF	Drive Error
Charging Circuit Error	PU	/	/	Flash 17 times	PU	PU	Drive Error
Unit n communication error	See Table 5	Flash 6 times	/	/	E6	E6	Indoor
Unit n indoor pipe midway temperature sensor error	See Table 5	/	Flash twice	/	E2	E2	Indoor
Indoor Evaporator Temp Sensor Short/ Open-Circuit	See Table 5	/	Flash twice	/	F2	F2	Indoor
(Air Valve) Unit n indoor unit pipe outlet temperature sensor error	See Table 5	/	Flash 22 times	/	b7	b7	Indoor
(Liquid Valve) Unit n indoor pipe inlet temperature sensor error	See Table 5	/	Flash 19 times	/	b5	b5	Indoor
Unit n mode conflict	See Table 5	/	Flash once	/	F1	F1	Indoor
Mode Conflict	See Table 5	Flash 7 times	/	/	E7	E7	Indoor

Error Code	Error Description	Error Code	Error Description	Error Code	Error Description
13	Unit A indoor unit pipe outlet temperature sensor error	23	Unit B indoor unit pipe outlet temperature sensor error	33	Unit C indoor unit pipe outlet temperature sensor error
14	Unit A indoor pipe inlet temperature sensor error	24	Unit B indoor pipe inlet temperature sensor error	34	Unit C indoor pipe inlet temperature sensor error
15	Unit A indoor ambient temperature sensor error	25	Unit B indoor ambient temperature sensor error	35	Unit C indoor ambient temperature sensor error
16	Unit A mode conflict	26	Unit B mode conflict	36	Unit C mode conflict
17	Unit A anti-freezing protection	27	Unit B anti-freezing protection	37	Unit C anti-freezing protection
41	Unit D communication error	46	Unit D mode conflict	54	Unit E indoor pipe inlet temperature sensor error
42	Unit D indoor pipe midway temperature sensor error	47	Unit D anti-freezing protection	55	Unit E indoor ambient temperature sensor error
43	Unit D indoor unit pipe outlet temperature sensor error	51	Unit E communication error	56	Unit E mode conflict
44	Unit D indoor pipe inlet temperature sensor error	52	Unit E indoor pipe midway temperature sensor error	57	Unit E anti-freezing protection
45	Unit D indoor ambient temperature sensor error	53	Unit E indoor unit pipe outlet temperature sensor error	C5	Jumper terminal error

Table 5

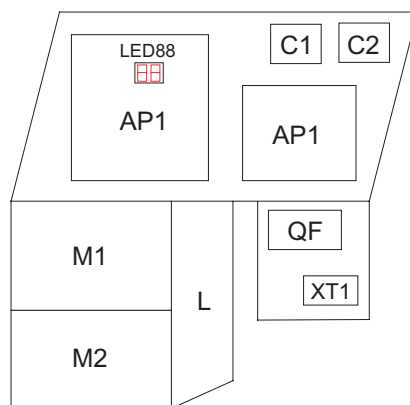

Outdoor Unit: GWHD(36)NK3BO, GWHD(42)NK3AO

(Note: Refer to the real products for the exact position of each component.)

Once errors are displayed on the controller, please shut off the air conditioning unit and contact the professionally skilled personnel for troubleshooting.

1.4 After-Sales Service

If there is any quality or other issue, please contact the GREE after-sales service center.

2. Flow Chart of Troubleshooting

Service personnel shall collect the malfunction information as much as possible and research them thoroughly, list these electrical parts which may cause malfunction, service personnel shall be able to determine the specific reason and solve the faulted parts.

Observe the status of the complete device and do not observe the partial

It is advised to start from the simple operation during analyzing ,judging and confirming malfunction reason, then conduct the complicated operations such removal of device, part replacement and refrigerant filling.

Find the malfunction reason carefully as unit may occur several malfunction at the same time and one malfunction may develop into several malfunction, so entire system analysis shall be established to make the judged result exact and credible.

◆ Malfunction display: E1 Compressor High Pressure Protection

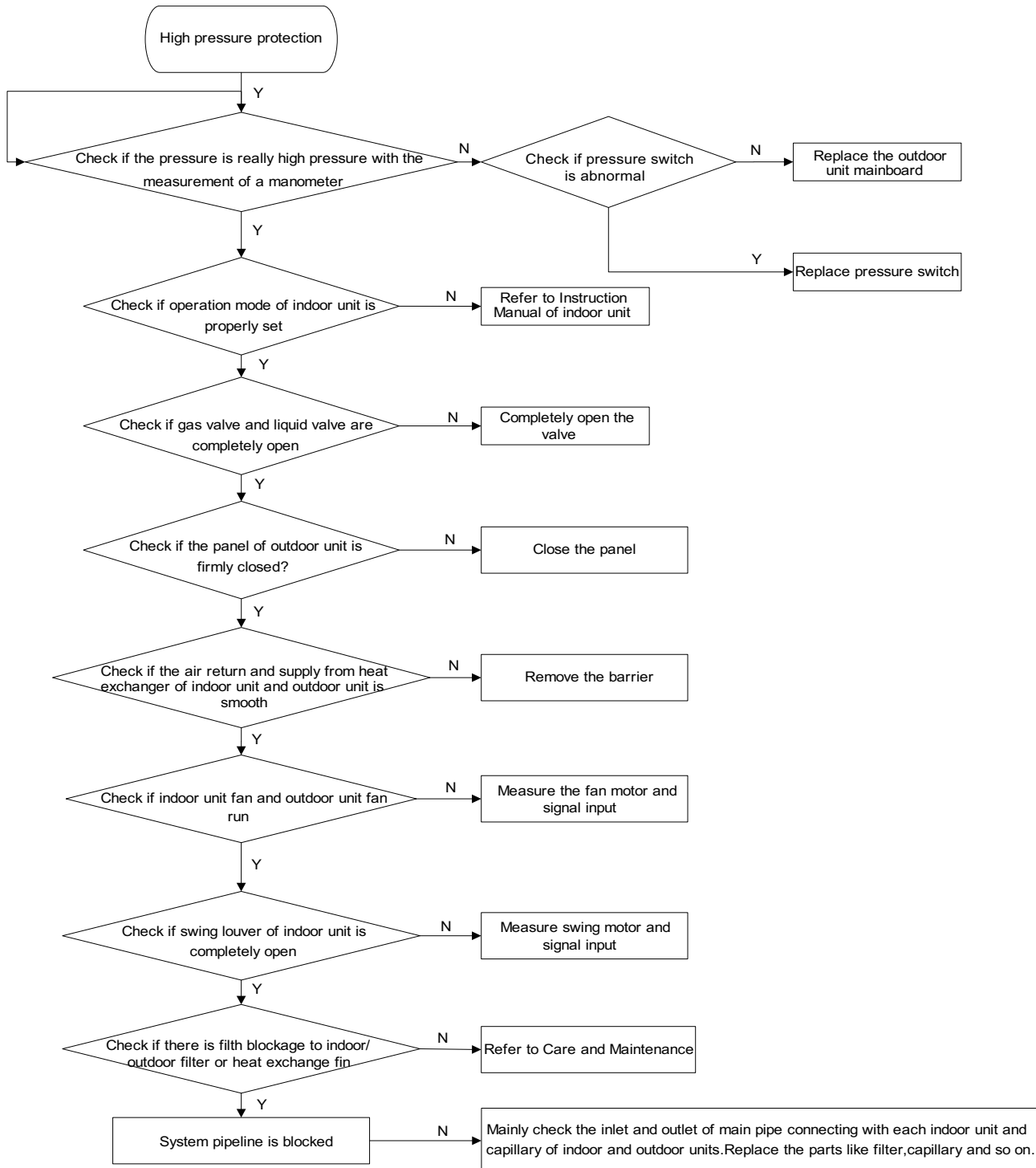

◆ Malfunction display: E3 Compressor Low Pressure Protection

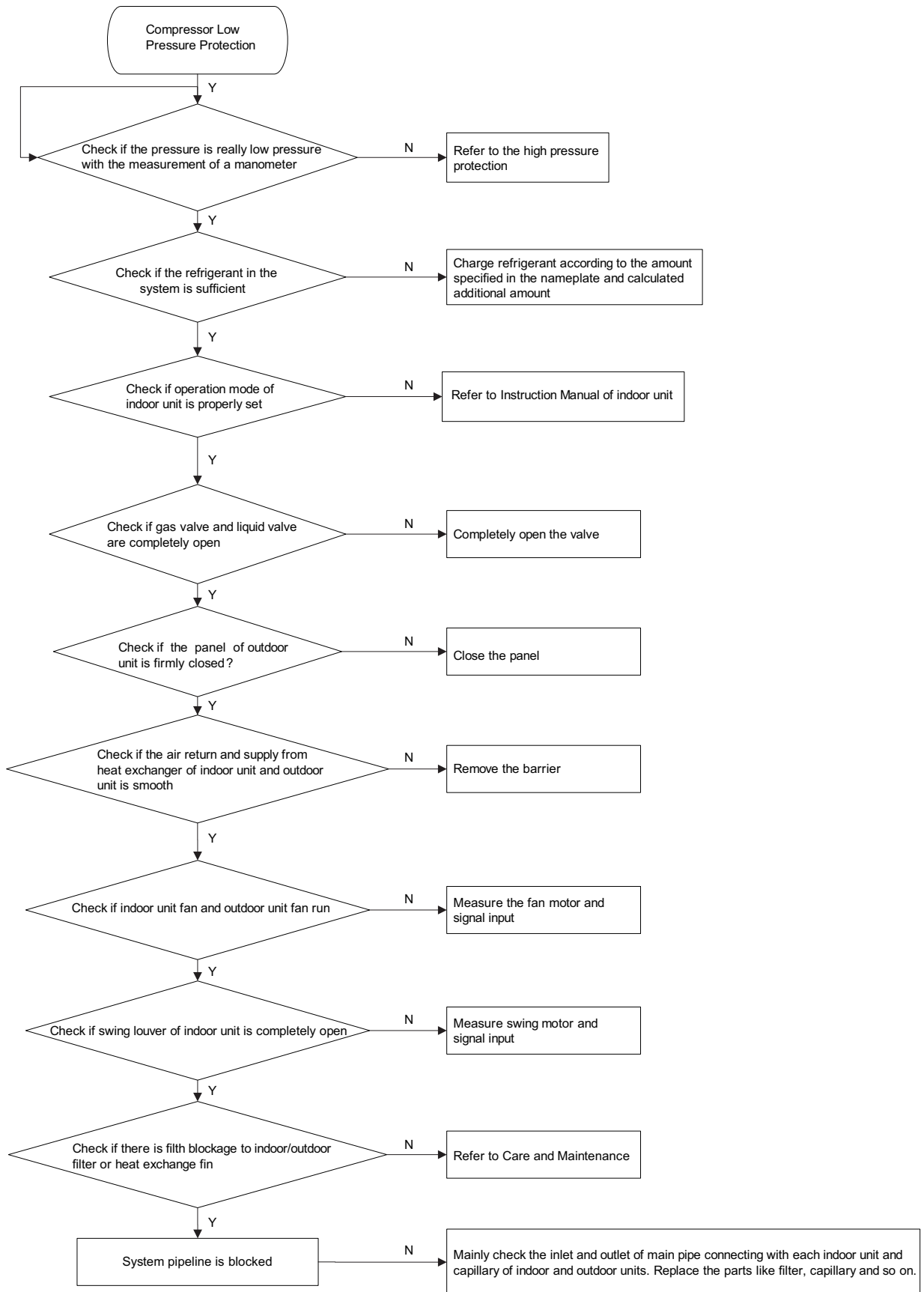

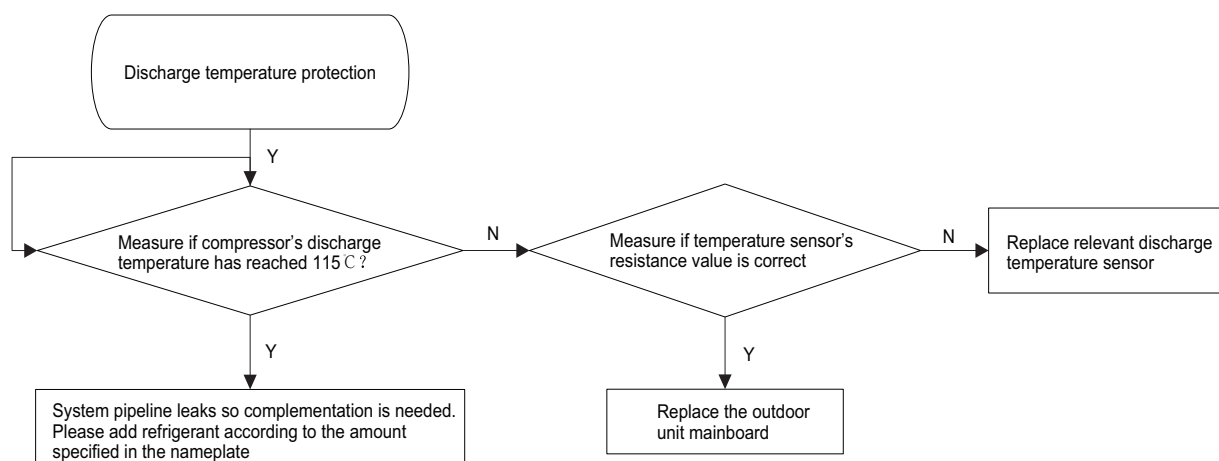
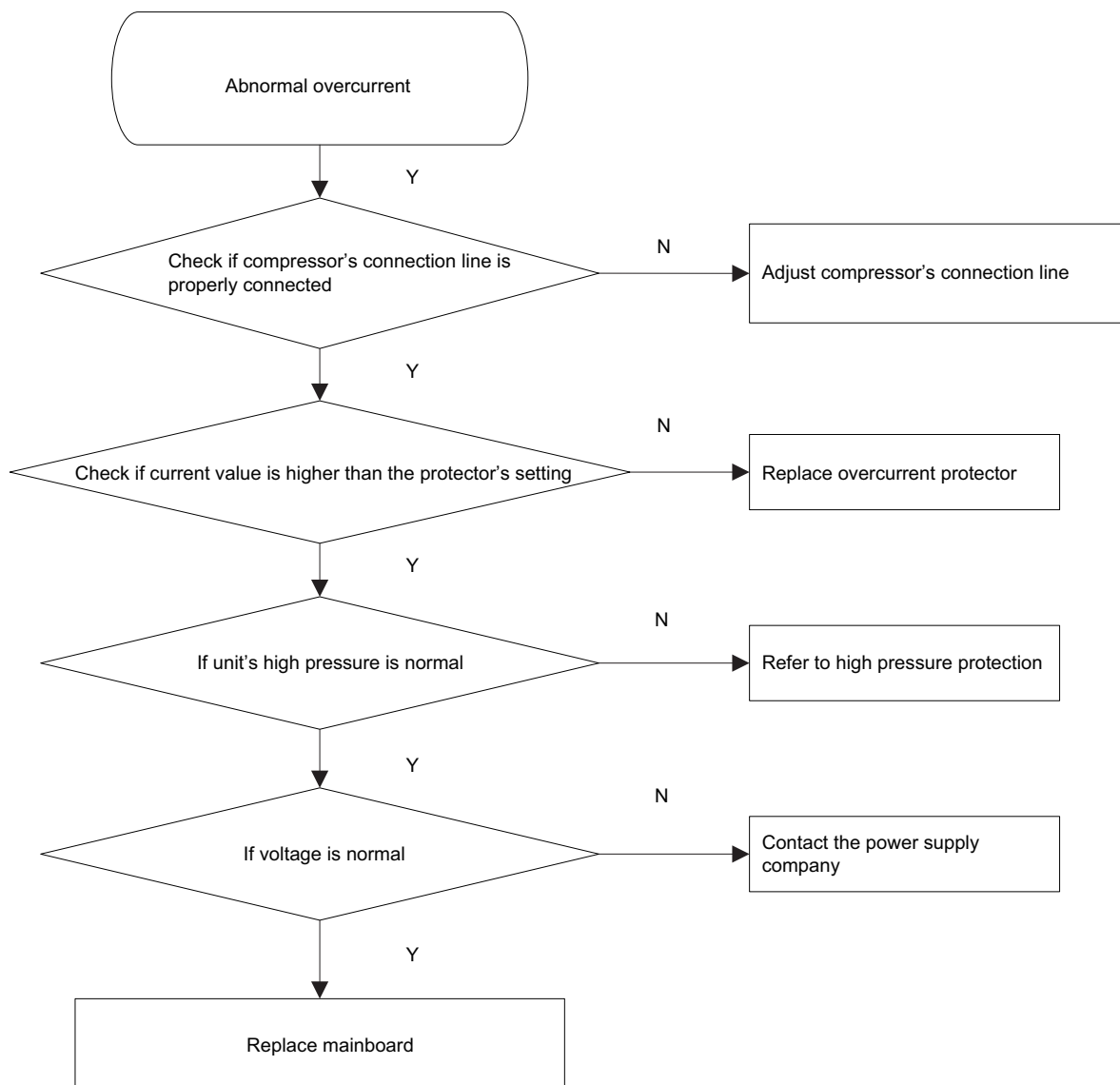
◆ Malfunction display: E4 Compressor Exhaust High Temperature Protection**◆ Malfunction display: E5 Compressor Overheat**

◆ Malfunction display: E9 Full Water Protection

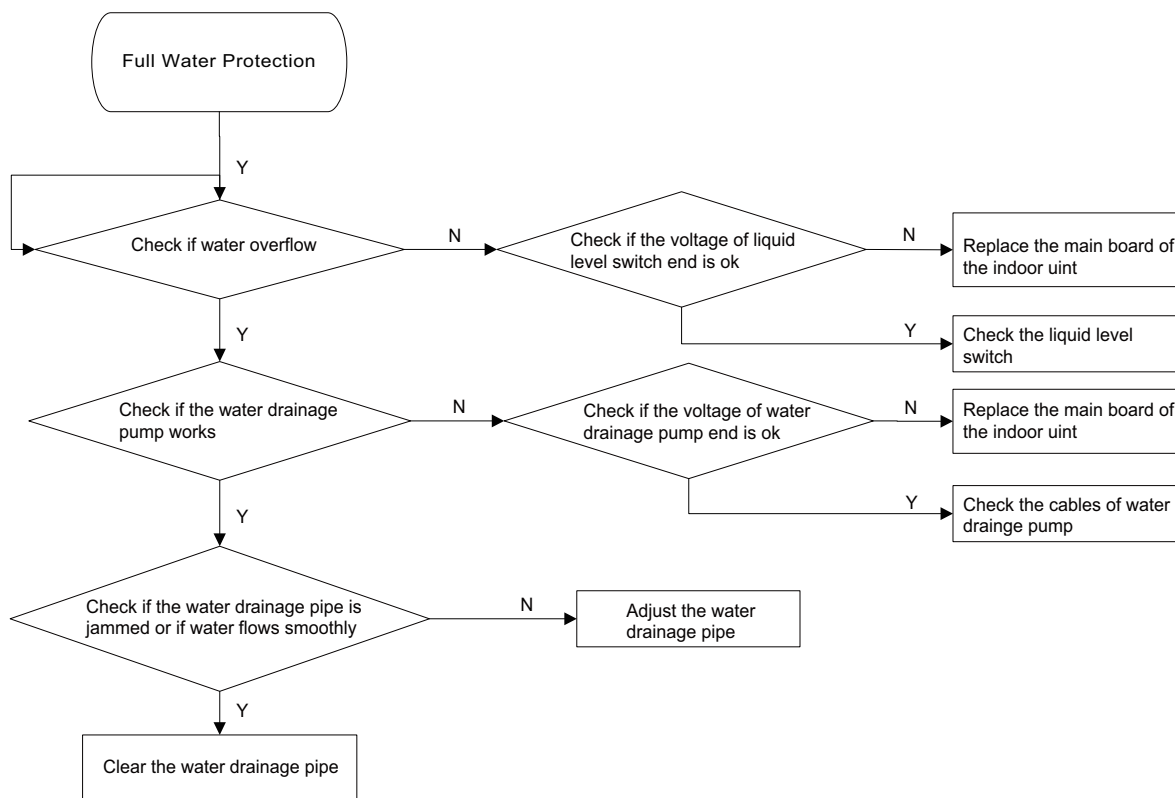

◆ Malfunction display: F2 Failure of Evaporator Temp. Sensor

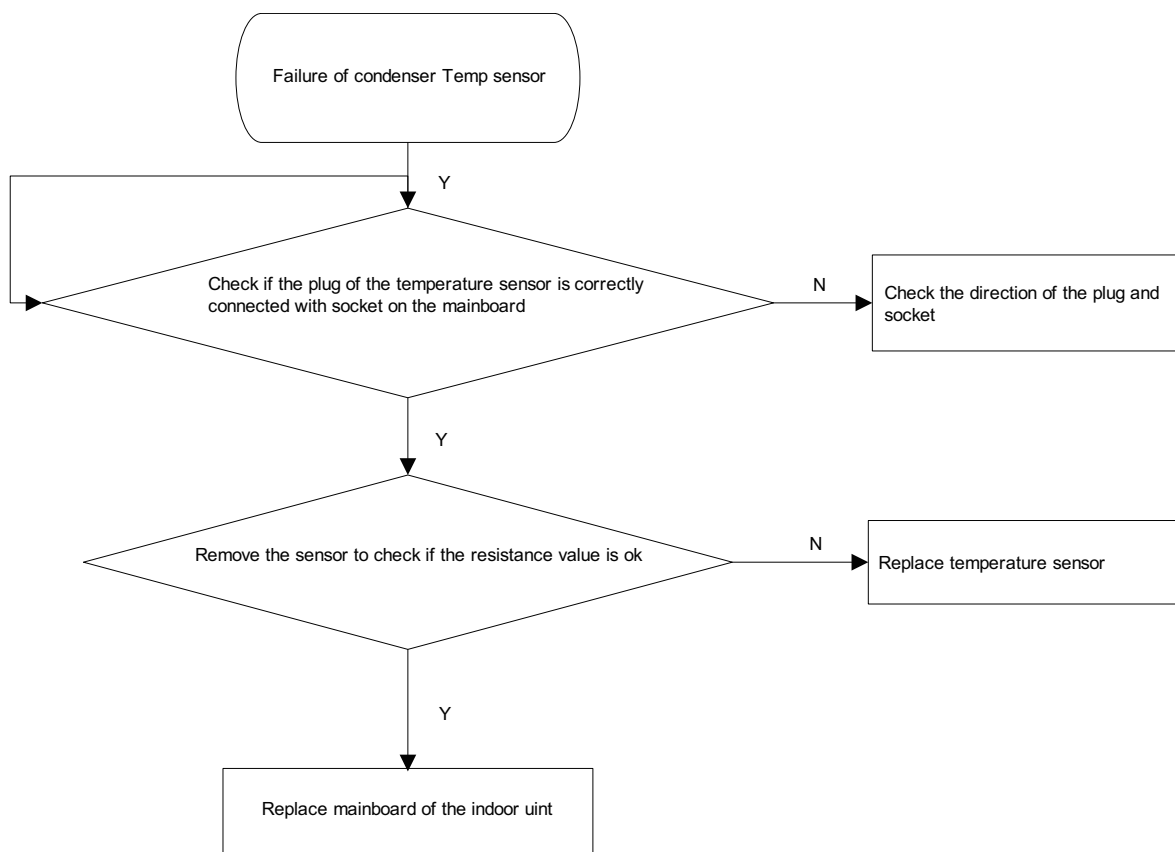

◆ Malfunction display: F3 Failure of Outdoor Ambient Sensor

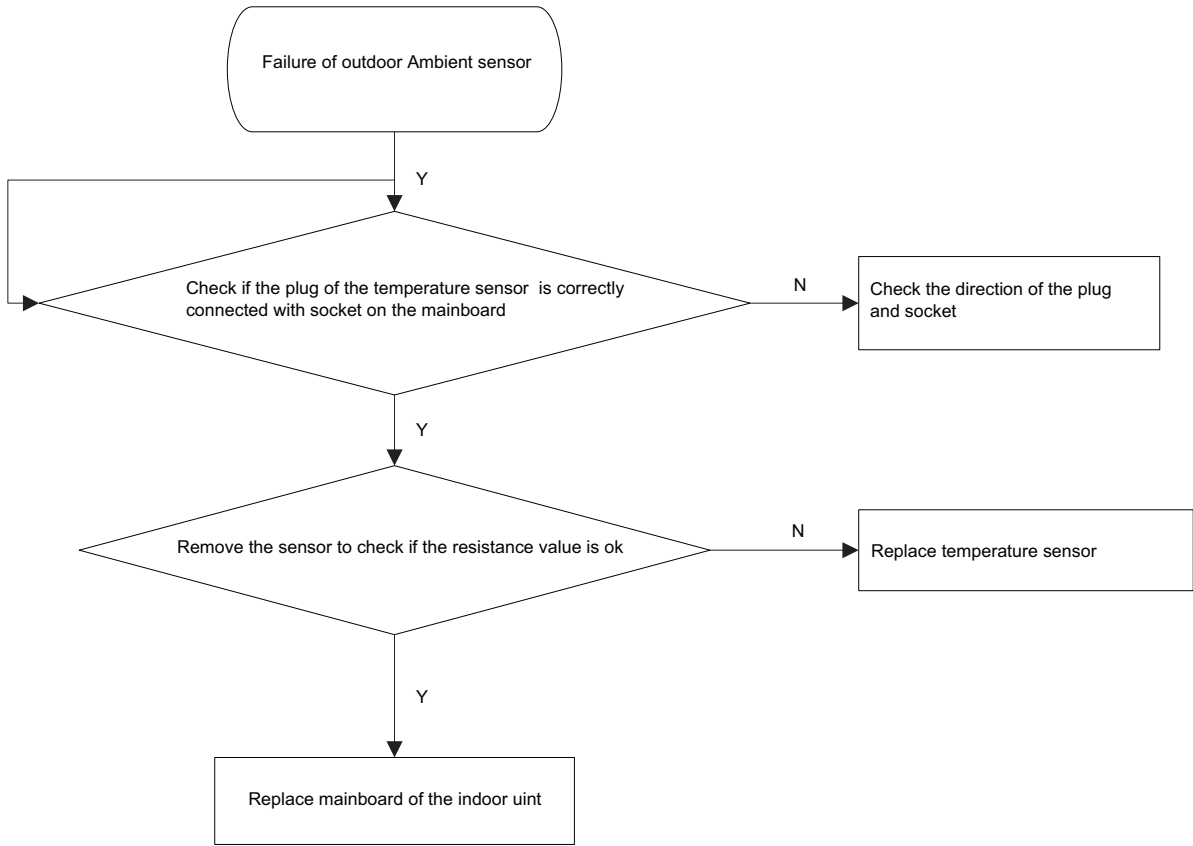

◆ Malfunction display: F5 Failure of Exhaust Temp. Sensor

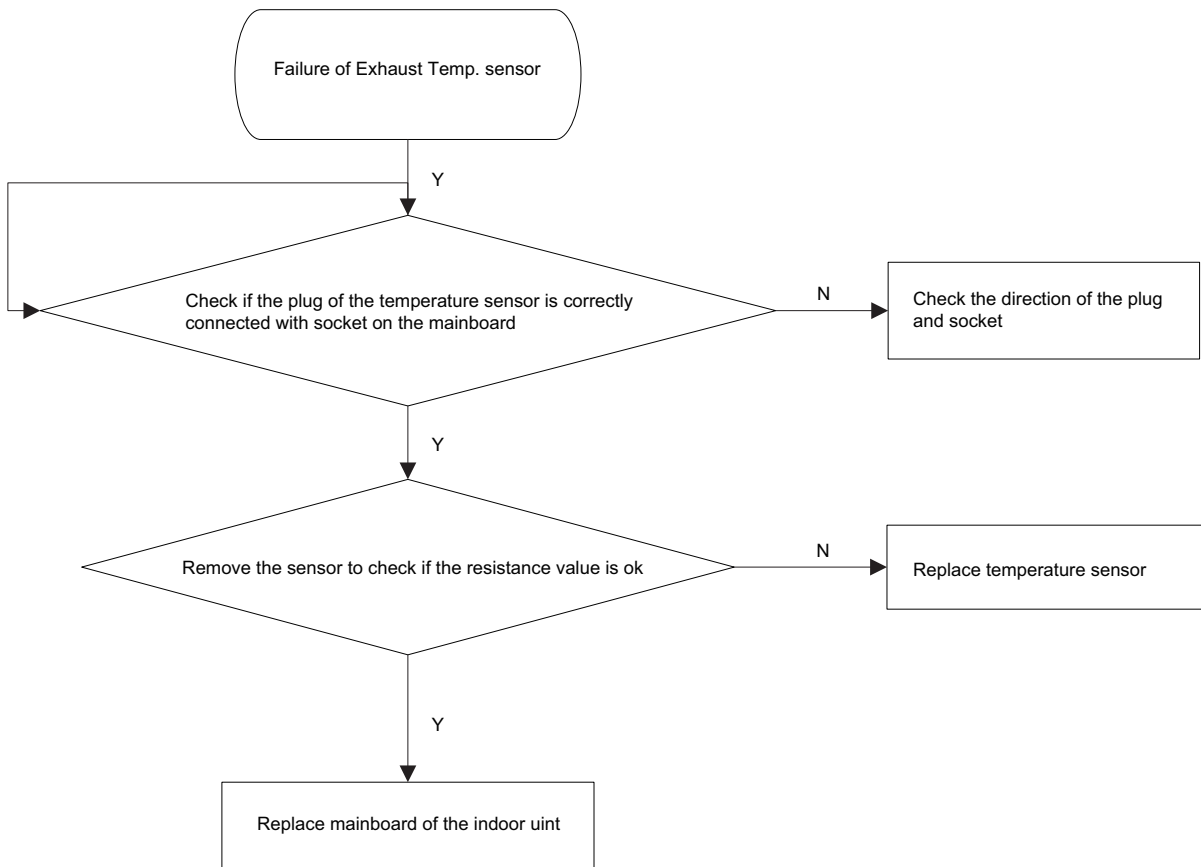

9.4 Maintenance Method for Normal Malfunction

1. Air Conditioner Can't be Started Up

Possible Causes	Discriminating Method (Air conditioner Status)	Troubleshooting
No power supply, or poor connection for power plug	After energization, operation indicator isn't bright and the buzzer can't give out sound	Confirm whether it's due to power failure. If yes, wait for power recovery. If not, check power supply circuit and make sure the power plug is connected well.
Wrong wire connection between indoor unit and outdoor unit, or poor connection for wiring terminals	Under normal power supply circumstances, operation indicator isn't bright after energization	Check the circuit according to circuit diagram and connect wires correctly. Make sure all wiring terminals are connected firmly
Electric leakage for air conditioner	After energization, room circuit breaker trips off at once	Make sure the air conditioner is grounded reliably Make sure wires of air conditioner is connected correctly Check the wiring inside air conditioner. Check whether the insulation layer of power cord is damaged; if yes, place the power cord.
Model selection for air switch is improper	After energization, air switch trips off	Select proper air switch
Malfunction of remote controller	After energization, operation indicator is bright, while no display on remote controller or buttons have no action.	Replace batteries for remote controller Repair or replace remote controller

2. Poor Cooling (Heating) for Air Conditioner

Possible Causes	Discriminating Method (Air conditioner Status)	Troubleshooting
Set temperature is improper	Observe the set temperature on remote controller	Adjust the set temperature
Rotation speed of the IDU fan motor is set too low	Small wind blow	Set the fan speed at high or medium
Filter of indoor unit is blocked	Check the filter to see it's blocked	Clean the filter
Installation position for indoor unit and outdoor unit is improper	Check whether the installation position is proper according to installation requirement for air conditioner	Adjust the installation position, and install the rainproof and sunproof for outdoor unit
Refrigerant is leaking	Discharged air temperature during cooling is higher than normal discharged wind temperature; Discharged air temperature during heating is lower than normal discharged wind temperature; Unit's pressure is much lower than regulated range	Find out the leakage causes and deal with it. Add refrigerant.
Malfunction of 4-way valve	blow cold wind during heating	Replace the 4-way valve
Malfunction of capillary	Discharged air temperature during cooling is higher than normal discharged wind temperature; Discharged air temperature during heating is lower than normal discharged wind temperature; Unit's pressure is much lower than regulated range. If refrigerant isn't leaking, part of capillary is blocked	Replace the capillary
Flow volume of valve is insufficient	Pressure at the valve is much lower than the regulated range	Open the valve completely
Malfunction of horizontal louver	Horizontal louver can't swing	Refer to point 3 of maintenance method for details
Malfunction of the IDU fan motor	The IDU fan motor can't operate	Refer to troubleshooting for H6 for maintenance method in details
Malfunction of the ODU fan motor	The ODU fan motor can't operate	Refer to point 4 of maintenance method for details
Malfunction of compressor	Compressor can't operate	Refer to point 5 of maintenance method for details

3. Horizontal Louver Can't Swing

Possible Causes	Discriminating Method (Air conditioner Status)	Troubleshooting
Wrong wire connection, or poor connection	Check the wiring status according to circuit diagram	Connect wires according to wiring diagram to make sure all wiring terminals are connected firmly
Stepping motor is damaged	Stepping motor can't operate	Repair or replace stepping motor
Main board is damaged	Others are all normal, while horizontal louver can't operate	Replace the main board with the same model

4. ODU Fan Motor Can't Operate

Possible causes	Discriminating method (air conditioner status)	Troubleshooting
Wrong wire connection, or poor connection	Check the wiring status according to circuit diagram	Connect wires according to wiring diagram to make sure all wiring terminals are connected firmly
Capacity of the ODU fan motor is damaged	Measure the capacity of fan capacitor with an universal meter and find that the capacity is out of the deviation range indicated on the nameplate of fan capacitor.	Replace the capacity of fan
Power voltage is a little low or high	Use universal meter to measure the power supply voltage. The voltage is a little high or low	Suggest to equip with voltage regulator
Motor of outdoor unit is damaged	When unit is on, cooling/heating performance is bad and ODU compressor generates a lot of noise and heat.	Change compressor oil and refrigerant. If no better, replace the compressor with a new one

5. Compressor Can't Operate

Possible causes	Discriminating method (air conditioner status)	Troubleshooting
Wrong wire connection, or poor connection	Check the wiring status according to circuit diagram	Connect wires according to wiring diagram to make sure all wiring terminals are connected firmly
Capacity of compressor is damaged	Measure the capacity of fan capacitor with an universal meter and find that the capacity is out of the deviation range indicated on the nameplate of fan capacitor.	Replace the compressor capacitor
Power voltage is a little low or high	Use universal meter to measure the power supply voltage. The voltage is a little high or low	Suggest to equip with voltage regulator
Coil of compressor is burnt out	Use universal meter to measure the resistance between compressor terminals and it's 0	Repair or replace compressor
Cylinder of compressor is blocked	Compressor can't operate	Repair or replace compressor

6. Air Conditioner is Leaking

Possible causes	Discriminating method (air conditioner status)	Troubleshooting
Drain pipe is blocked	Water leaking from indoor unit	Eliminate the foreign objects inside the drain pipe
Drain pipe is broken	Water leaking from drain pipe	Replace drain pipe
Wrapping is not tight	Water leaking from the pipe connection place of indoor unit	wrap it again and bundle it tightly

7. Abnormal Sound and Vibration

Possible causes	Discriminating method (air conditioner status)	Troubleshooting
When turn on or turn off the unit, the panel and other parts will expand and there's abnormal sound	There's the sound of "PAPA"	Normal phenomenon. Abnormal sound will disappear after a few minutes.
When turn on or turn off the unit, there's abnormal sound due to flow of refrigerant inside air conditioner	Water-running sound can be heard	Normal phenomenon. Abnormal sound will disappear after a few minutes.
Foreign objects inside the indoor unit or there're parts touching together inside the indoor unit	There's abnormal sound fro indoor unit	Remove foreign objects. Adjust all parts' position of indoor unit, tighten screws and stick damping plaster between connected parts
Foreign objects inside the outdoor unit or there're parts touching together inside the outdoor unit	There's abnormal sound fro outdoor unit	Remove foreign objects. Adjust all parts' position of outdoor unit, tighten screws and stick damping plaster between connected parts
Short circuit inside the magnetic coil	During heating, the way valve has abnormal electromagnetic sound	Replace magnetic coil
Abnormal shake of compressor	Outdoor unit gives out abnormal sound	Adjust the support foot mat of compressor, tighten the bolts
Abnormal sound inside the compressor	Abnormal sound inside the compressor	If add too much refrigerant during maintenance, please reduce refrigerant properly. Replace compressor for other circumstances.

10. Exploded View and Parts List

(1) Model:GWHD(18)NK3FO

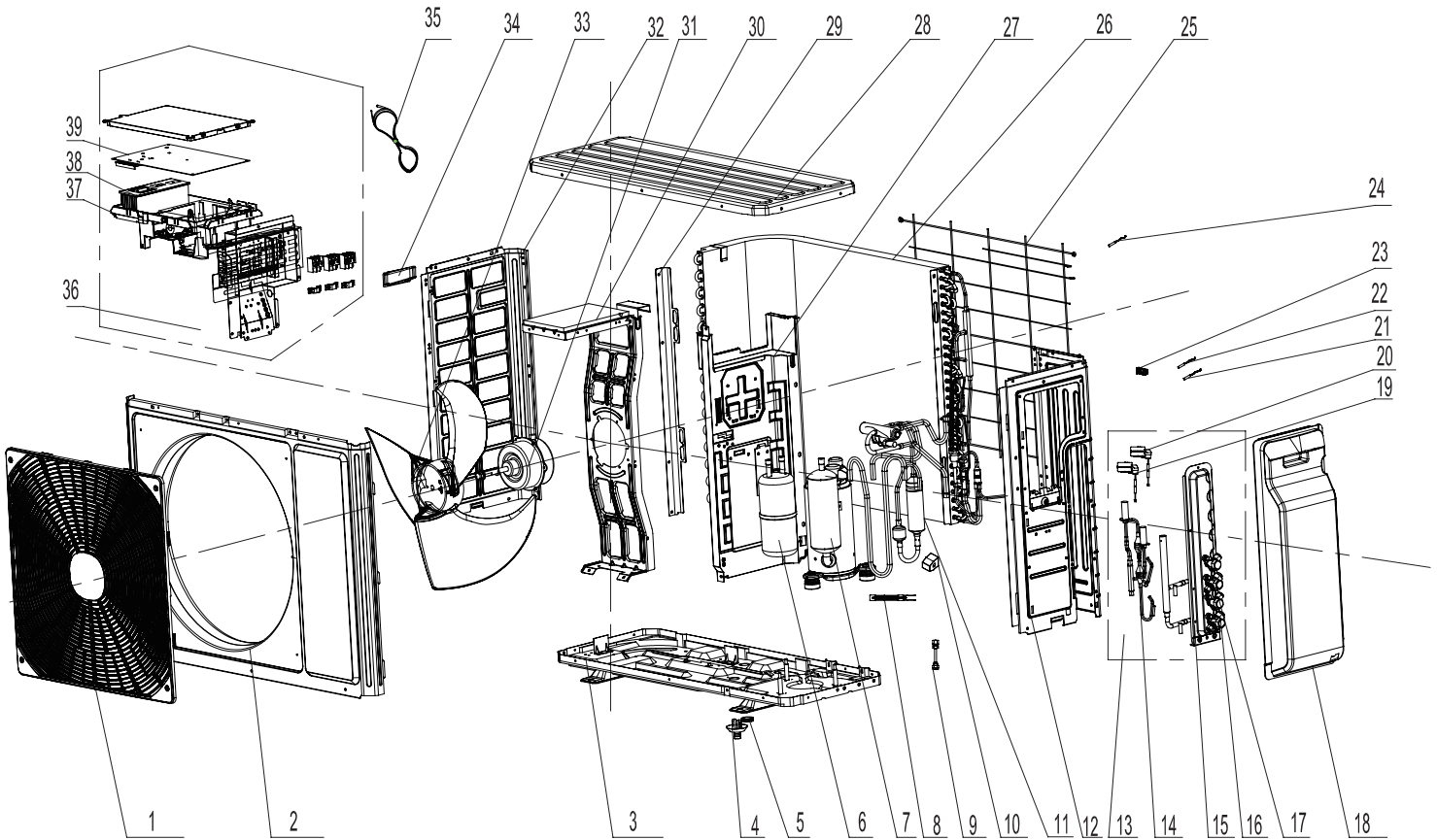

NO.	Description	Part Code		Qty
		GWHD(18)NK3FO	GWHD(18)NK3FO	
		Product Code	Product Code	
1	Front Grill	22413025	22413025	1
2	Front Panel	01535013P	01535013P	1
3	Chassis Sub-assy	02803263P	02803302P	1
4	Drainage Connector	06123401	06123401	1
5	Drainage hole Cap	06813401	06813401	3
6	Gas-liquid Separator Assy	07225017	07225017	1
7	Compressor and Fittings	00105249G	00105249G	1
8	Electric Heater(Compressor)	32003001	32003001	1
9	Tube Connector Sub-assy	06643008	06643008	1
10	Magnet Coil	4300040033	4300040033	1
11	4-Way Valve Assy	03073156	03073156	1
12	Right Side Plate	01303268P	01303268P	1
13	Valve Support Assy	07133845	07133845	1
14	Electronic Expansion Valve assy	07133846	07133846	1
15	Valve Support Sub-Assy	0171312802P	0171312802P	1
16	Cut off Valve	071302391	071302391	1
17	Cut off Valve	07130239	07130239	1
18	Valve Cover	20123029	20123029	1
19	Electric Expand Valve Fitting	43000084	43000084	1
20	Electric Expand Valve Fitting	4300008401	43000084	1
21	Temperature Sensor	3900007301	3900007301	1
22	Temperature Sensor	39000073	39000073	1
23	Wiring Clamp	26115004	26115004	1
24	Temperature Sensor	3900030901	3900030901	1
25	Rear Grill	01473043	01473043	1
26	Condenser Assy	01163938	01163938	1
27	Clapboard Assy	0123315301	0123315301	1
28	Coping	01255005P	01255005P	1
29	Supporting Board(Condenser)	01795010	01795010	1
30	Motor Support Sub-Assy	01705036	01705036	1
31	Fan Motor	1501506402	1501506402	1
32	Left Side Plate	01305093P	01305093P	1
33	Axial Flow Fan	10335008	10335008	1
34	Left Handle	26235401	26235401	1
35	Connecting Cable	4002054026	4002054026	0
36	Electric Box Assy	02613683	02613929	1
37	Electric Box	20113027	20113027	1
38	Radiator	49010252	49010252	1
39	Main Board	30148897	30148876	1

Above data is subject to change without notice.

(2) Model:GWHD(24)NK3FO

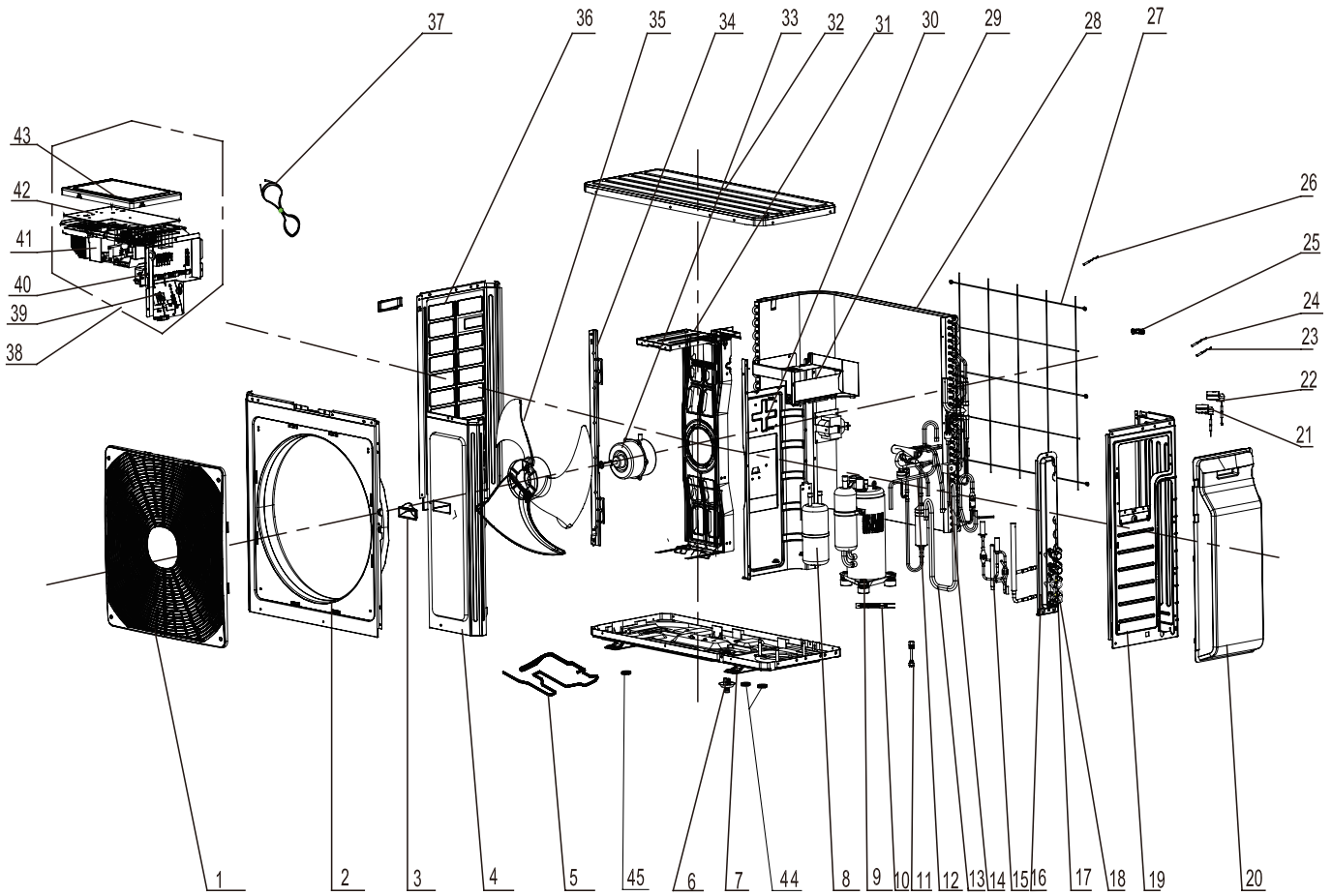

NO.	Description	Part Code	Qty
		GWHD(24)NK3FO	
	Product Code	CB228W03301	
1	Front Grill	22413026	1
2	Cabinet	01435004P	1
3	Left Handle	26235401	2
4	Front Side Plate	01305086P	1
5	Electrical Heater (Chassis)	7651000411	1
6	Drainage Connector	06123401	1
7	Chassis Sub-assy	02803280P	1
8	Gas-liquid Separator Assy	07225017	1
9	Compressor and Fittings	0010524501G	1
10	Electric Heater(Compressor)	7651873215	1
11	Tube Connector Sub-assy	06643008	1
12	4-Way Valve Assy	03073181	1
13	Connection Pipe	05113723	1
14	Magnet Coil	4300040045	1
15	Electronic Expansion Valve assy	0713385802	1
16	Valve Support Assy	0713385702	1
17	Cut off Valve	07130239	1
18	Cut off Valve	071302391	1
19	Right Side Plate	01314100009P	1
20	Valve Cover	26904100012	1
21	Electric Expand Valve Fitting	43000084	1
22	Electric Expand Valve Fitting	4300008401	1
23	Temperature Sensor	3900007304	1
24	Temperature Sensor	3900007305	1
25	Wiring Clamp	26115004	1
26	Temperature Sensor	3900030901	1
27	Rear Grill	01574100003	1
28	Condenser Assy	01163980	1
29	Electric Box (Fireproofing)	01413426	1
30	Clapboard Sub-Assy	01233190	1
31	Motor Support Sub-Assy	01705025	1
32	Coping	01255006P	1
33	Fan Motor	1501403402	1
34	Condenser Support Plate	01175092	1
35	Axial Flow Fan	10335014	1
36	Left Side Plate	01305043P	1
37	Connecting Cable	4002054026	0
38	Electric Box Assy	02613684	1
39	Terminal Board	420111041	2
40	Connection Support	01703211	1
41	Electric Box	20113015	1
42	Main Board	30148903	1
43	Electric Box Cover Sub-Assy	02603217	1
44	Drainage hole Cap	7671301802	2
45	Drainage hole Cap	0681340101	1

Above data is subject to change without notice.

(3) Model:GWHD(24)NK3GO

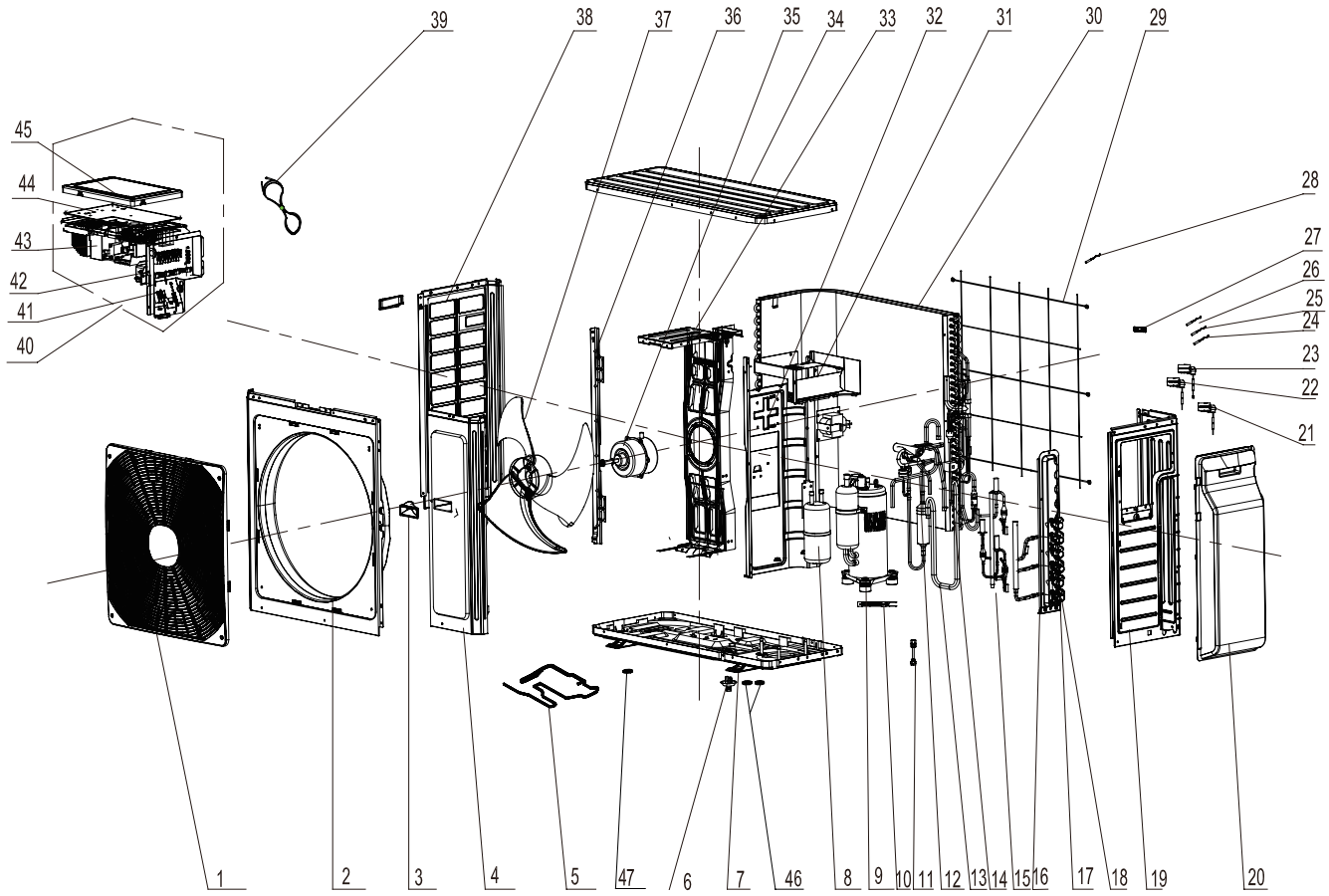

NO.	Description	Part Code	Qty
		GWHD(24)NK3GO	
		Product Code CB228W03401	
1	Front Grill	22413026	1
2	Cabinet	01435004P	1
3	Left Handle	26235401	2
4	Front Side Plate	01305086P	1
5	Electrical Heater (Chassis)	7651000411	1
6	Drainage Connector	06123401	1
7	Chassis Sub-assy	02803280P	1
8	Gas-liquid Separator Assy	07225017	1
9	Compressor and Fittings	0010524501G	1
10	Electric Heater(Compressor)	7651873215	1
11	Tube Connector Sub-assy	06643008	2
12	4-Way Valve Assy	03073181	1
13	Connection Pipe	05113723	1
14	Magnet Coil	4300040045	1
15	Electronic Expansion Valve assy	0713385802	1
16	Valve Support Assy	0713385701	1
17	Cut off Valve	07130239	1
18	Cut off Valve	071302391	1
19	Right Side Plate	01314100009P	1
20	Valve Cover	26904100012	1
21	Electric Expand Valve Fitting	/	0
22	Electric Expand Valve Fitting	43000084	1
23	Electric Expand Valve Fitting	4300008401	1
24	Temperature Sensor	3900007304	1
25	Temperature Sensor	3900007305	1
26	Temperature Sensor	3900030901	1
27	Wiring Clamp	26115004	1
28	Temperature Sensor	3900007304	1
29	Rear Grill	01574100003	1
30	Condenser Assy	01163980	1
31	Electric Box (Fireproofing)	01413426	1
32	Clapboard Sub-Assy	01233190	1
33	Motor Support Sub-Assy	01705025	1
34	Coping	01255006P	1
35	Fan Motor	1501403402	1
36	Condenser Support Plate	01175092	1
37	Axial Flow Fan	10335014	1
38	Left Side Plate	01305043P	1
39	Connecting Cable	4002054026	0
40	Electric Box Assy	02613685	1
41	Terminal Board	420111041	3
42	Connection Support	01703211	1
43	Electric Box	20113015	1
44	Main Board	30148905	1
45	Electric Box Cover Sub-Assy	02603217	1
46	Drainage hole Cap	7671301802	2
47	Drainage hole Cap	0681340101	1

The data above are subject to change without notice.

(4) Model:GWHD(28) NK3FO

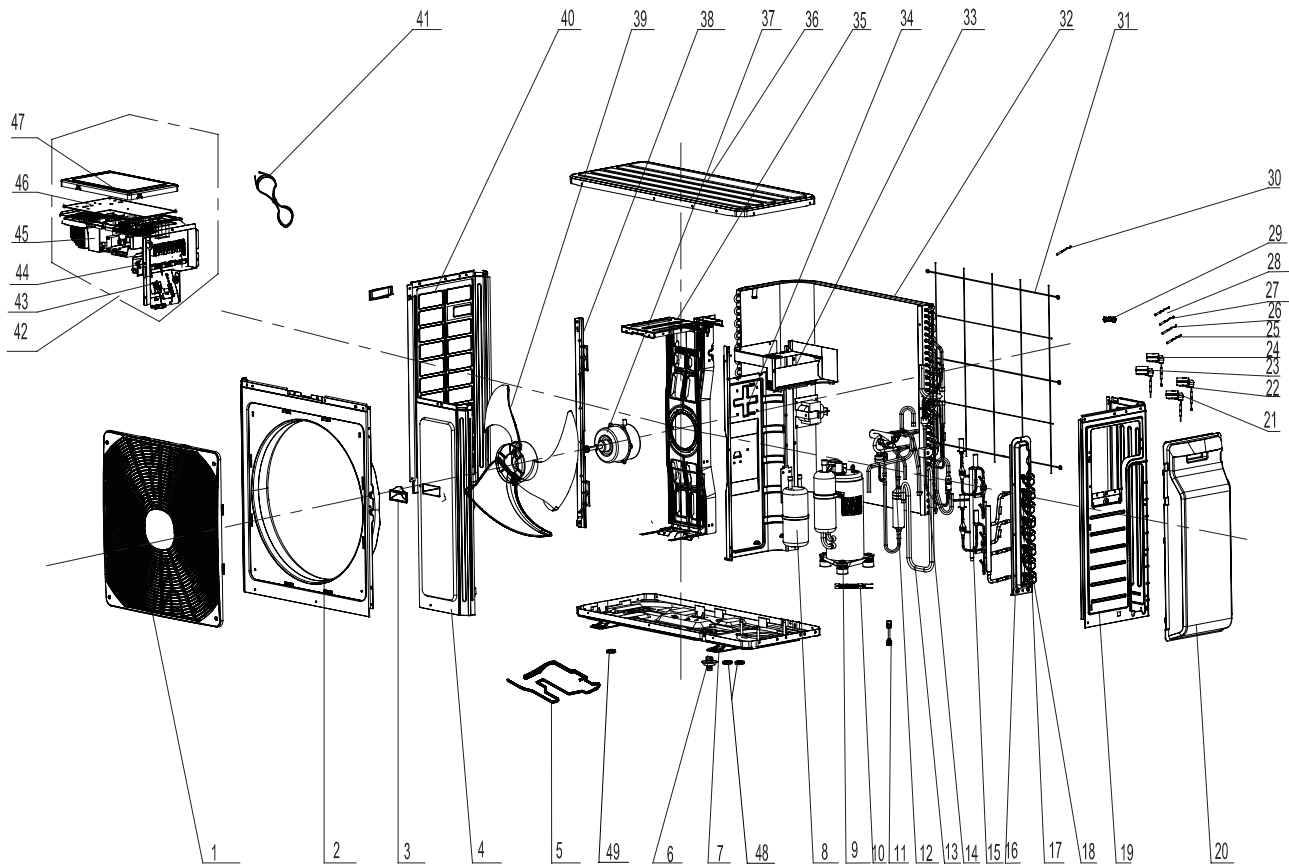

NO.	Description	Part Code		Qty
		GWHD(28) NK3FO	GWHD(28) NK3FO	
		Product Code	Product Code	
1	Front Grill	22413026	22413026	1
2	Cabinet	01435004P	01435004P	1
3	Left Handle	26235401	26235401	2
4	Front Side Plate	01305086P	01305086P	1
5	Electrical Heater (Chassis)	7651000411	/	1
6	Drainage Connector	06123401	06123401	1
7	Chassis Sub-assy	02803280P	02803301P	1
8	Gas-liquid Separator Assy	07225017	07225017	1
9	Compressor and Fittings	0010524501G	0010524501G	1
10	Electric Heater(Compressor)	7651873215	7651873215	1
11	Tube Connector Sub-assy	06643008	06643008	2
12	4-Way Valve Assy	03073181	03073181	1
13	Connection Pipe	05113723	05113723	1
14	Magnet Coil	4300040045	4300040045	1
15	Electronic Expansion Valve assy	07133858	07133858	1
16	Valve Support Assy	07133857	07133857	1
17	Cut off Valve	07130239	07130239	1
18	Cut off Valve	071302391	071302391	1
19	Right Side Plate	0131410009P	0131410009P	1
20	Valve Cover	26904100012	26904100012	1
21	Electric Expand Valve Fitting	43000084	43000084	1
22	Electric Expand Valve Fitting	4300008401	4300008401	1
23	Electric Expand Valve Fitting	4300008402	4300008402	1
24	Electric Expand Valve Fitting	4300008403	4300008403	1
25	Temperature Sensor	3900007303	3900007303	1
26	Temperature Sensor	3900007302	3900007302	1
27	Temperature Sensor	3900007301	3900007301	1
28	Temperature Sensor	39000073	39000073	1
29	Wiring Clamp	26115004	26115004	1
30	Temperature Sensor	3900030901	3900007304	1
31	Rear Grill	01574100003	01574100003	1
32	Condenser Assy	01163980	01163980	1
33	Electric Box (Fireproofing)	01413426	01413426	1
34	Clapboard Sub-Assy	01233190	01233190	1
35	Motor Support Sub-Assy	01705025	01705025	1
36	Coping	01255006P	01255006P	1
37	Fan Motor	1501403402	1501403402	1
38	Condenser Support Plate	01175092	01175092	1
39	Axial Flow Fan	10335014	10335014	1
40	Left Side Plate	01305043P	01305043P	1
41	Connecting Cable	4002054026	4002054026	0
42	Electric Box Assy	02613686	02613930	1
43	Terminal Board	420111041	420111041	4
44	Connection Support	01703211	01703211	1
45	Electric Box	20113015	20113015	1
46	Main Board	30148906	30148896	1
47	Electric Box Cover Sub-Assy	02603217	02603217	1
48	Drainage hole Cap	7671301802	0681340101	2
49	Drainage hole Cap	0681340101	0681340101	1

The data above are subject to change without notice.

(5) Models:GWHD(36)NK3BO(CN860W0130) GWHD(42)NK3AO(CN860W0020)

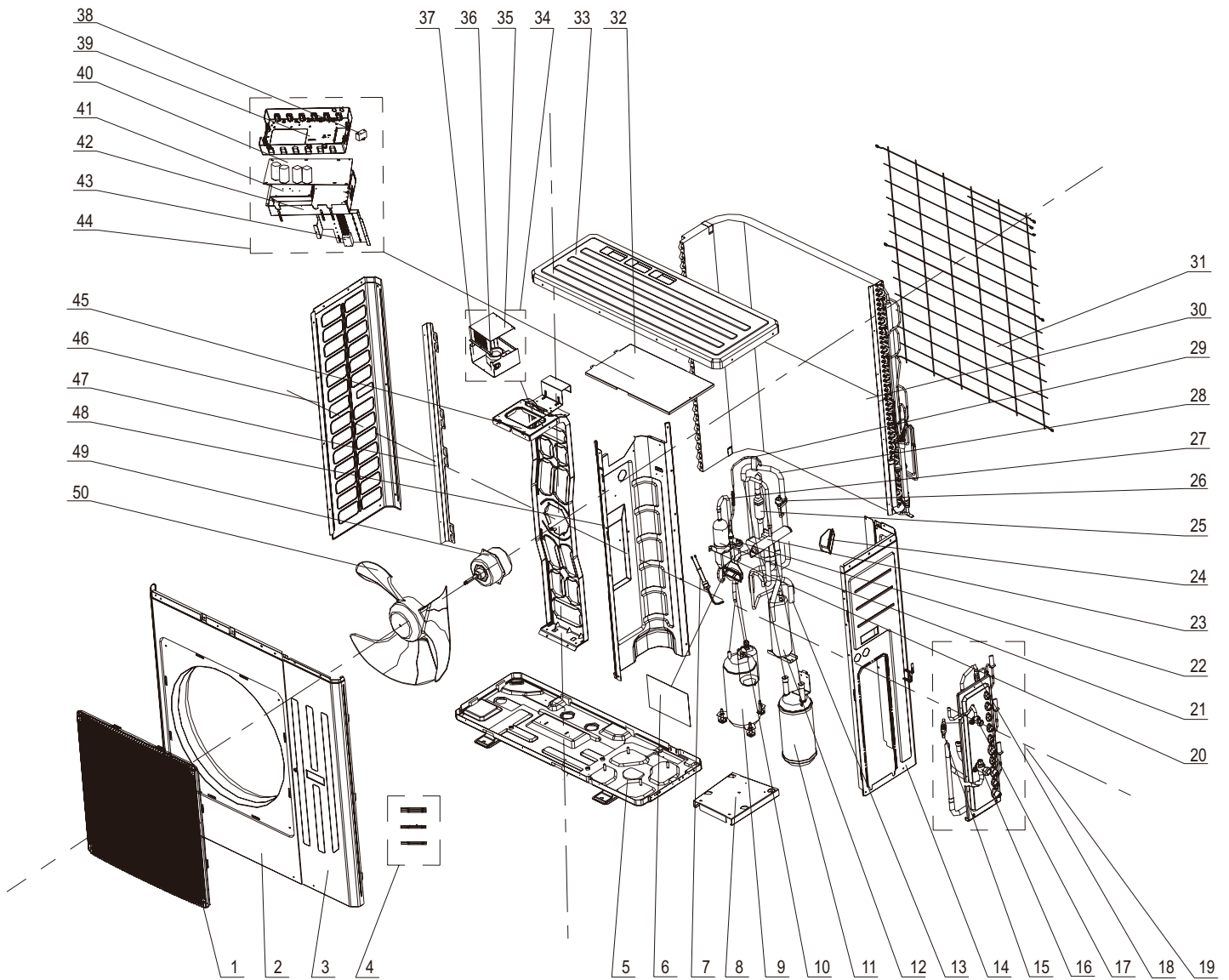

NO.	Description	Part Code		Qty
		GWHD(36)NK3BO	GWHD(42)NK3AO	
		Product code		
		CN860W0130	CN860W0020	
1	Front Grill	22415005	22415005	1
2	Cabinet	01435007P	01435007P	1
3	Front Side Plate Sub-Assy	01305508	01305508	1
4	Sensor sub-assy	39008000055G	39008066	1
5	Chassis Sub-assy	01194141P	01194141P	1
6	Insulated board (cover of electric box)	01425200068	20113003	1
7	Pressure Protect Switch	4602001573	460200902	1
8	Compressor Mounting Plate Sub-Assy	01324100026P	01324238	1
9	Compressor and fittings	00205200003	00205230	1
10	Connection Pipe	05034330	05034302	1
11	Gas-liquid Separator Sub-Assy	0722501801	07225018	1
12	Bidirection Accumulator	07228741	07228741	1
13	connecting pipe of "U"shape	05034290	05034290	1
14	Right Side Plate Sub-Assy	01314304P	01314304	1
15	StrainerA	07210031	07210022	1
16	Cut-off Valve	07334402	07334403	1
17	Cut-off Valve	07334402	07334402	1
18	StrainerA	07415200002	07210022	1
19	Valve support assy	01804100229	01804238	1
20	Oil Separator	07228302	07228302	1
21	Tube Clip	0214000521	0214000521	1
22	StrainerA	07415200002	07210022	1
23	4-way Valve	4300008201	43000338	1
24	Handle	26235253	26235253	2
25	4-way Valve Assy	04044100026	04144185	1
26	Pressure Protect Switch	04044100027	4602001555	1
27	Discharge Tube Sub-Assy	04534100059	04634310	1
28	Inhalation Tube Sub-Assy	04554100057	04674230	1
29	Capillary Sub-Assy(Oil Separator)	04024100068	04104239	1
30	Condenser Assy	0112417902	01124179	1
31	Rear Grill	01475012	01475012	1
32	Electric Box Cover	01425200068	01424263	1
33	Top Cover	0125500901P	01255009	1
34	Reactor Sub-Assy	01394100122	02404111	1
35	Cover of Reactor box	01424260	01424260	1
36	PFC Inductance	43128003	43128003	1
37	Reactor Box	01424258	01424258	1
38	Capacitor	33010053	33010009	1
39	Electric Box	26905211	26905211	1
40	Main Board	30226000047	30226254	1
41	Radiator	49010252	49018112	1
42	Electric Box Sub-Assy	01395200266	02404112	1

43	Terminal Board	420111041	42010270	1
44	Electric Box Assy	01395200266	02404113	1
45	Motor Support Sub-Assy	01804100229	01805402	1
46	Left Side Plate	01305064P	01305064P	1
47	Condenser support plate	01895309	01895309	1
48	Clapboard	01244141	01244141	1
49	Fan Motor	1570280201	1570522801	1
50	Axial Flow Fan	10335010	10335010	1

Above data is subject to change without notice.

11. Removal Procedure



Warning: Be sure to wait for a minimum of 20 minutes after turning off all power supplies and discharge the refrigerant completely before removal.

(1) Model: GWHD(18)NK3FO

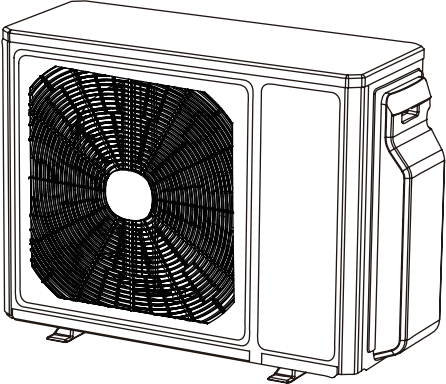
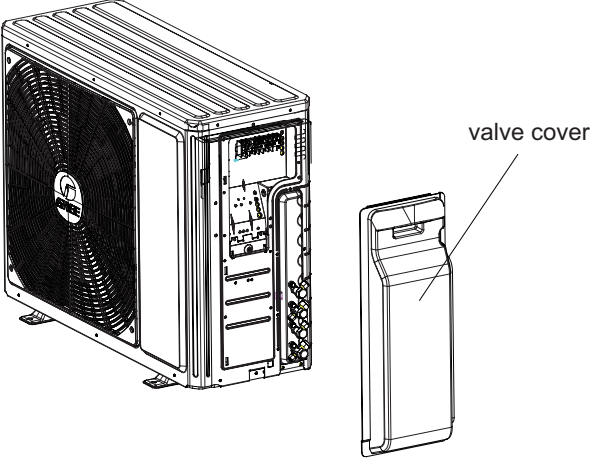
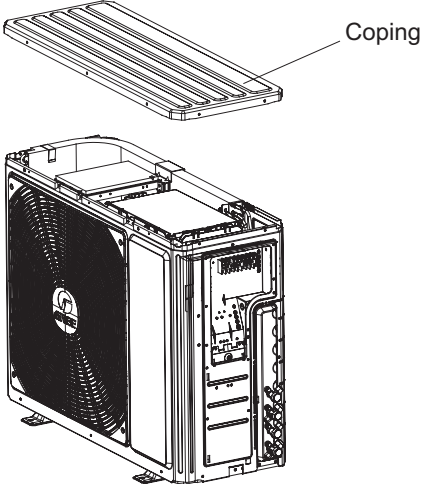
Steps	Procedure
1. Before disassembly	 <p>Complete axonometric drawing.</p>
2. Remove valve cover	 <p>Remove the connection screw fixing the valve cover and then remove the valve cover.</p>
3. Remove Coping	 <p>Remove the connection screws connecting the top panel with the right side plate and the left side plate, and then remove the Coping.</p>

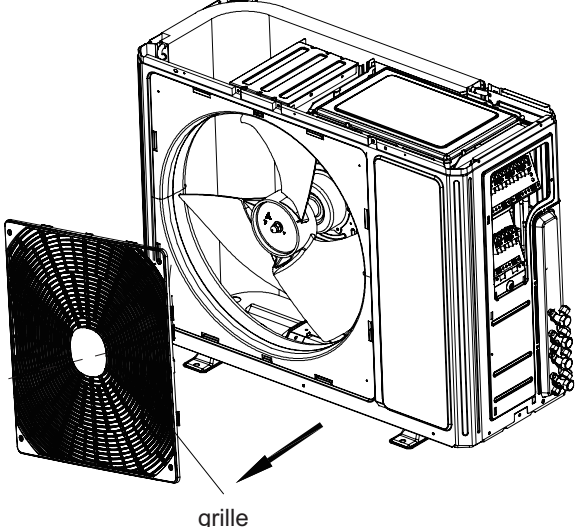
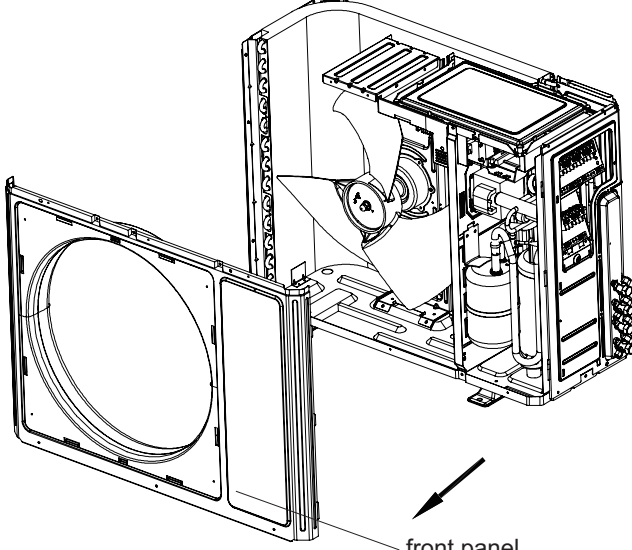
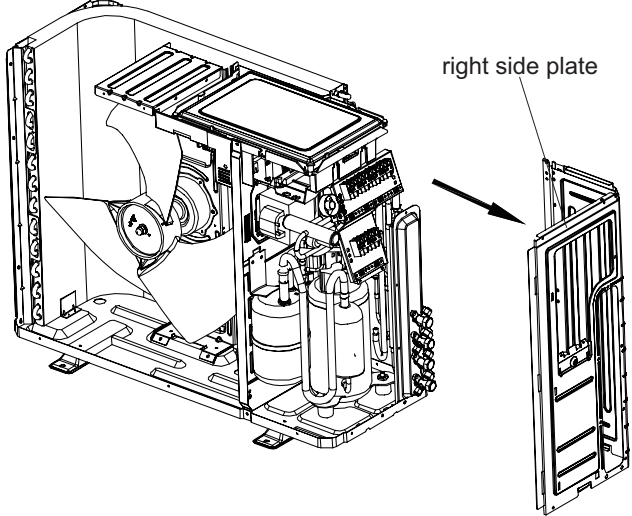
Steps	Procedure	
4. Remove front grille		
	<p>Remove the connection screws connecting the front grille and the front panel, and then loosen the clasp to remove the front grille.</p>	
5. Remove front panel		
	<p>Remove the screws connecting the front panel and then remove the front panel.</p>	
6. Remove right side plate		
	<p>Remove the screws connecting the right side plate with the chassis and the valve support. Then remove the right side plate.</p>	

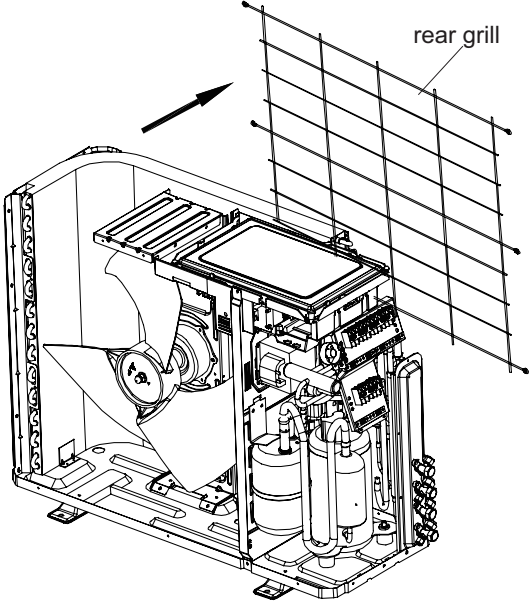
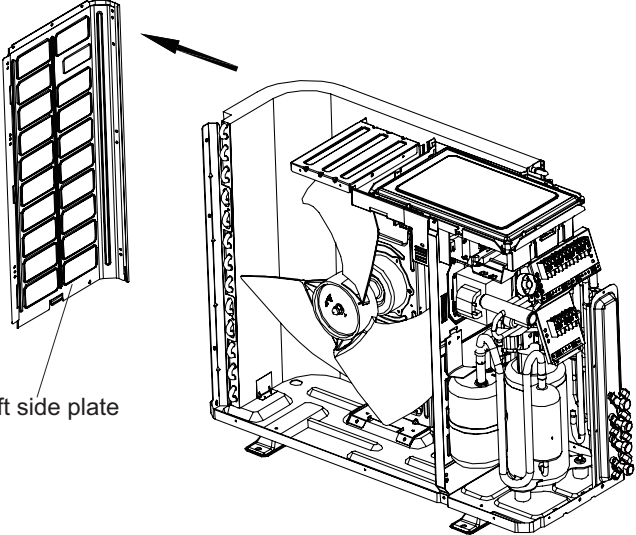
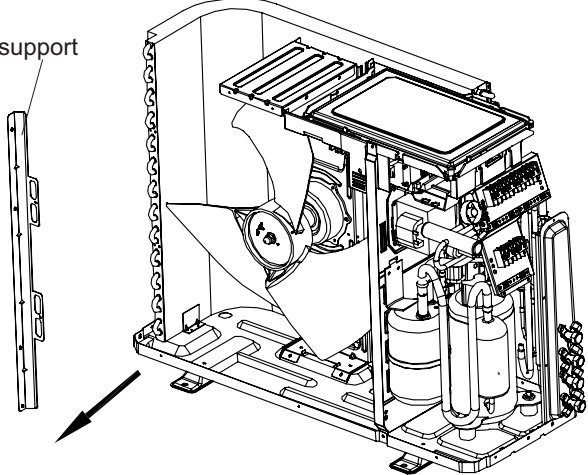
Steps	Procedure
<p>7. Remove rear grill</p>	<p>Remove the screws connecting the rear grill and the left side plate, and then remove the rear grill.</p>  <p>The diagram shows a perspective view of the unit's interior. A grid-like rear grill is being lifted away from the chassis. An arrow points from the grill towards the top right. A label 'rear grill' with a leader line points to the grid.</p>
<p>8. Remove left side plate</p>	<p>Remove the screws fixing the left side plate with the chassis and the condenser support, and then remove the left side plate.</p>  <p>The diagram shows the unit's interior with the left side plate being removed. An arrow points from the side plate towards the top left. A label 'left side plate' with a leader line points to the plate.</p>
<p>9. Remove condenser support</p>	<p>Remove the connection screws connecting the condenser support and the chassis, and then remove the condenser support.</p>  <p>The diagram shows the unit's interior with the condenser support being removed. An arrow points from the support towards the bottom left. A label 'support' with a leader line points to the support.</p>

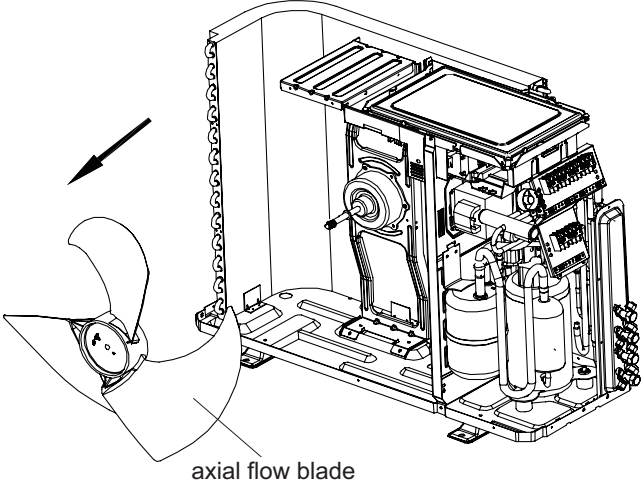
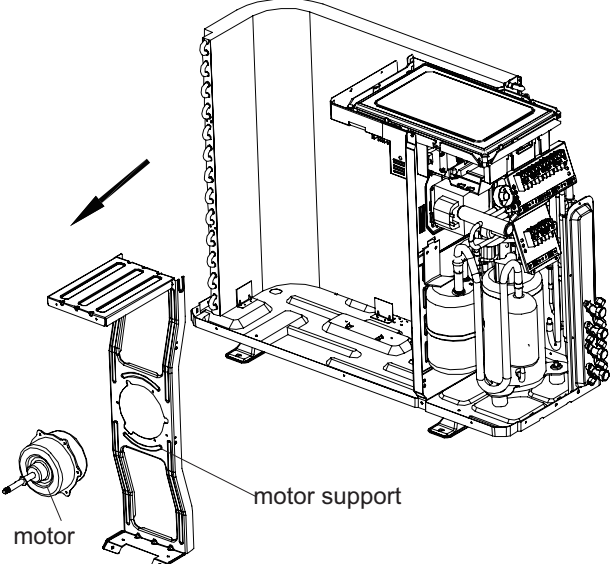
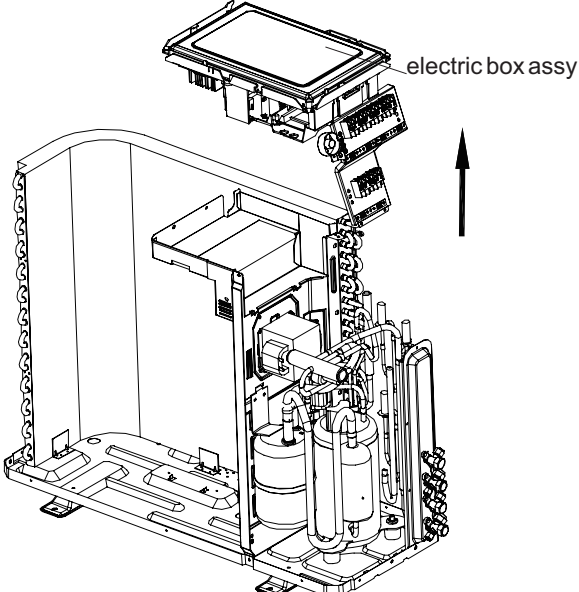
Steps	Procedure	
10. Remove axial flow blade	Remove the nut on the blade and then remove the axial flow blade.	
11. Remove motor and motor support	Remove the 4 tapping screws fixing the motor and disconnect the leading wire insert of the motor. Then remove the motor. Remove the 2 tapping screws fixing the motor support and chassis, and then lift the motor support to remove it.	
12. Remove electric box assy	Remove the screws fixing the electric box assy and the middle isolation sheet, and then lift the electric box assy to remove it.	

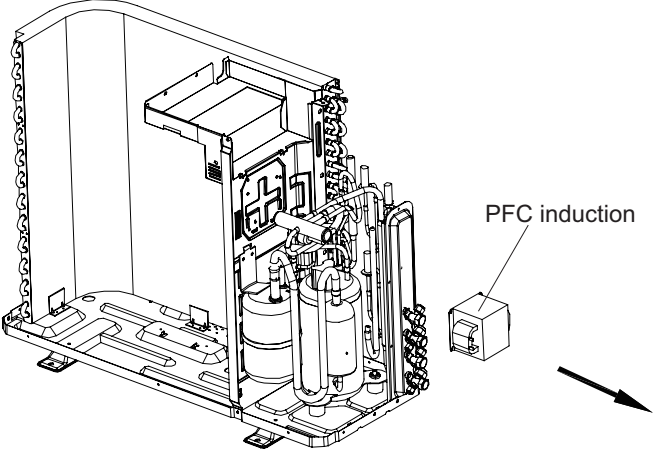
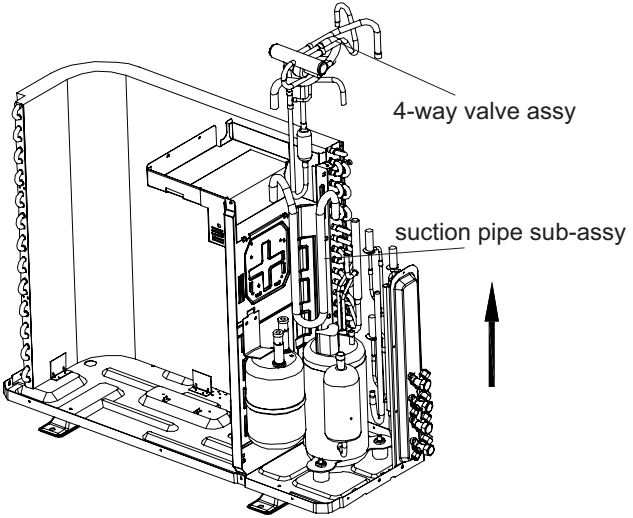
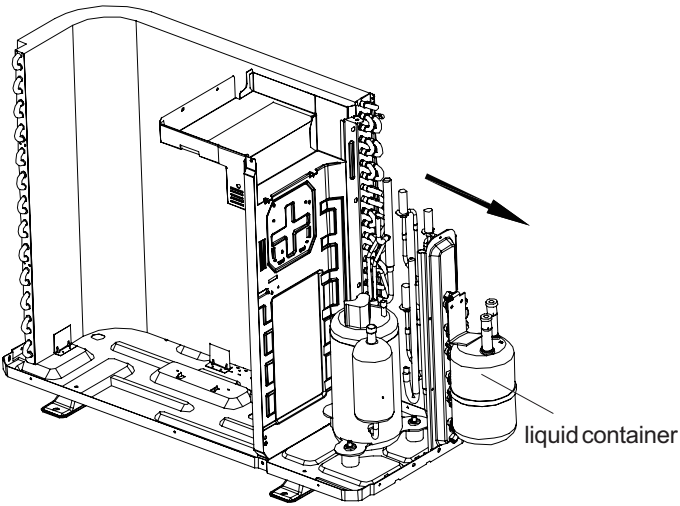
Steps	Procedure
13. Remove PFC induction	
	<p>Remove the screw connecting the PFC induction and middle isolation sheet, and then remove the PFC induction.</p> 
14. Remove 4-way valve assy and suction pipe sub-assy	
	<p>Unsolder the welding joint connecting the 4-way valve assy with compressor suction and discharge port, the valve with the outlet pipe of condenser. Then lift the 4-way valve assy to remove it. (NOTE: Discharge the refrigerant completely before unsoldering.) Unsolder the welding joint connecting the suction pipe sub-assy with compressor and liquid container, and then remove the suction pipe sub-assy.</p> 
15. Remove liquid container	
	<p>Remove the screws connecting the isolation plate sub-assy and the liquid container, and then lift the liquid container to remove it.</p> 

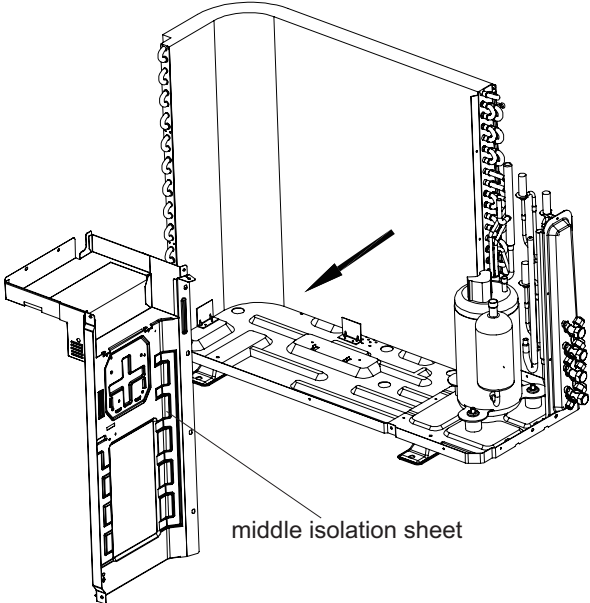
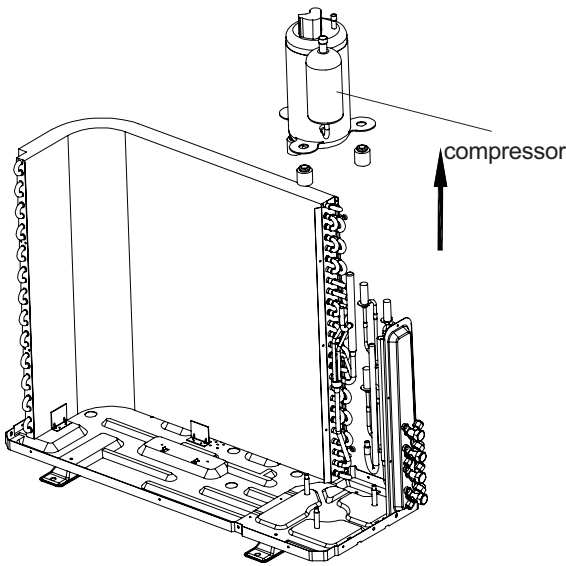
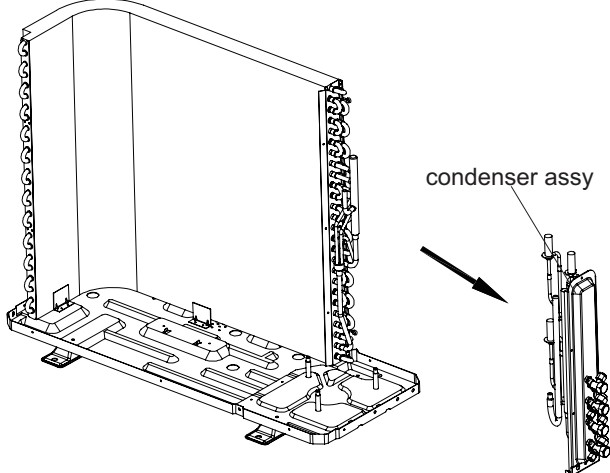
Steps	Procedure
<p>16. Remove middle isolation sheet</p>	<p>Remove the screws connecting the middle isolation sheet with the chassis assy and the condenser assy, and then remove the middle isolation sheet.</p>  <p>middle isolation sheet</p>
<p>17. Remove compressor</p>	<p>Remove the 3 foot nuts fixing the compressor and then remove the compressor.</p>  <p>compressor</p>
<p>18. Remove valve support sub-assy</p>	<p>Remove the screw connecting the valve support assy and the chassis sub-assy, and then remove the valve support assy.</p>  <p>condenser assy</p>

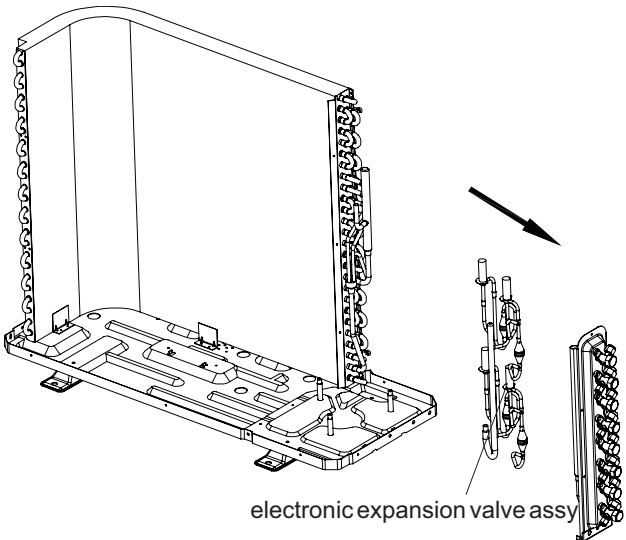
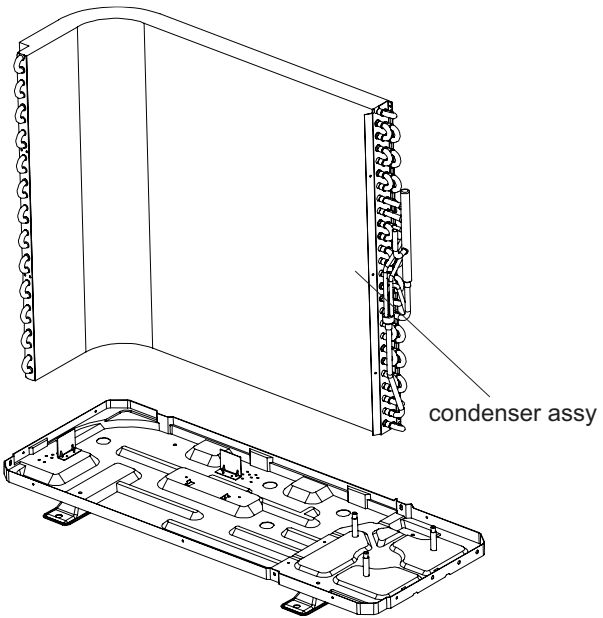
Steps	Procedure
19. Remove electronic expansion valve assy	<p data-bbox="224 456 818 628">Unsolder the welding joint connecting the electronic expansion valve sub-assy with the gas collection pipe, and then remove the electronic expansion valve assy. (Note: when unsoldering, wrap the gas valve with a wet cloth completely to avoid damage to the valve caused by high temperature).</p>  <p data-bbox="1115 773 1446 799">electronic expansion valve assy</p>
20. Remove condenser assy	<p data-bbox="224 1220 742 1308">Remove the screws connecting the condenser assy and the chassis assy, and then remove the condenser assy.</p>  <p data-bbox="1333 1340 1508 1367">condenser assy</p>

(2)Models:GWHD(24)NK3FO GWHD(24)NK3GO GWHD(28) NK3FO

Take GWHD(28) NK3FO for example(Only cut-off valve of valve support, electronic expansion valve and coil have some differences)

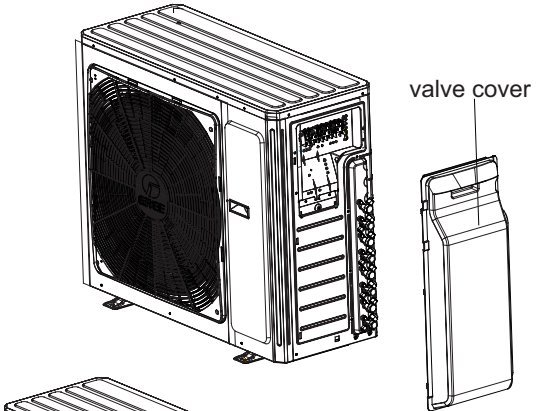
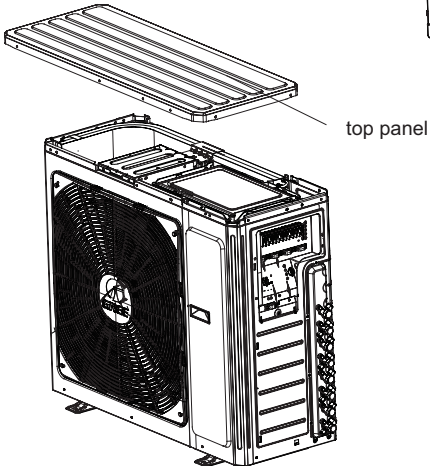
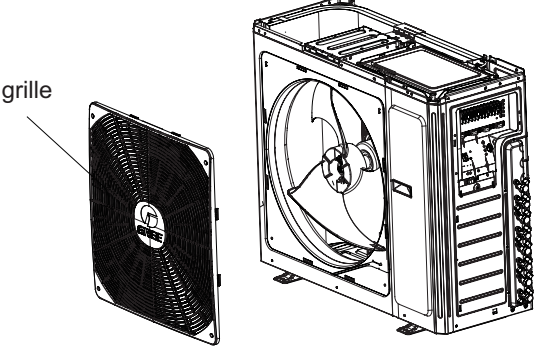
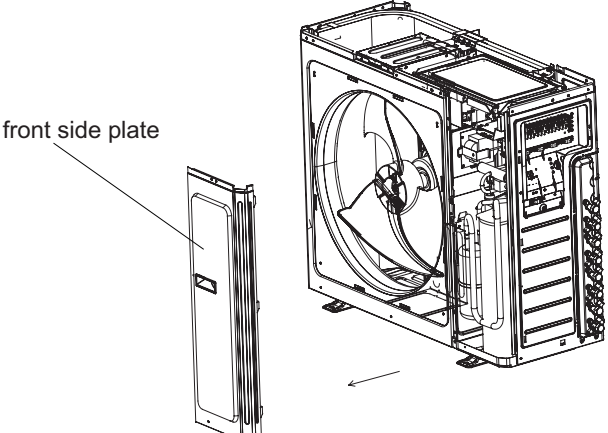
Steps	Procedure	
1. Remove valve cover and top panel		
1	Twist off the screws used for fixing and valve cover , pull valve cover up ward to remove it.	 <p>valve cover</p>
2	Remove the 3 screws connecting the top panel with the front panel and the right side plate, and then remove the top panel.	 <p>top panel</p>
2. Remove grille,front side plate and panel.		
1	Remove the 2 screws connecting the grille and the panel, and then remove the grille.	 <p>grille</p>
2	Remove the 1 screw connecting the front side plate and the panel,and then remove the front side plate.	 <p>front side plate</p>

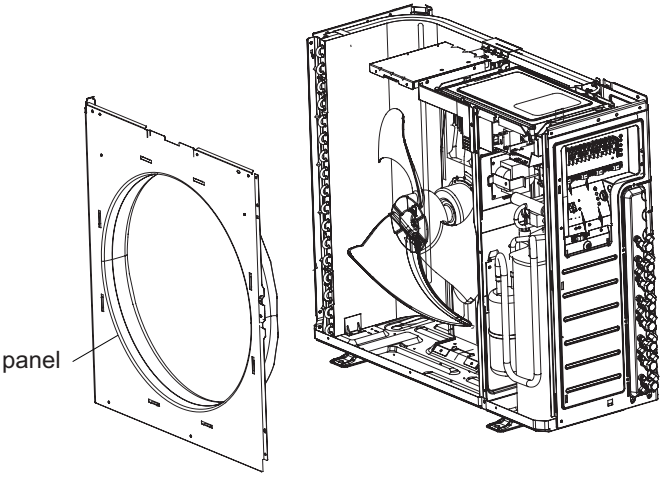
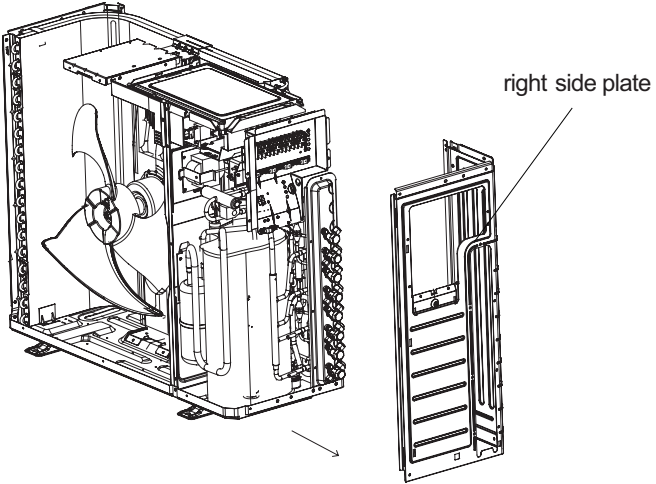
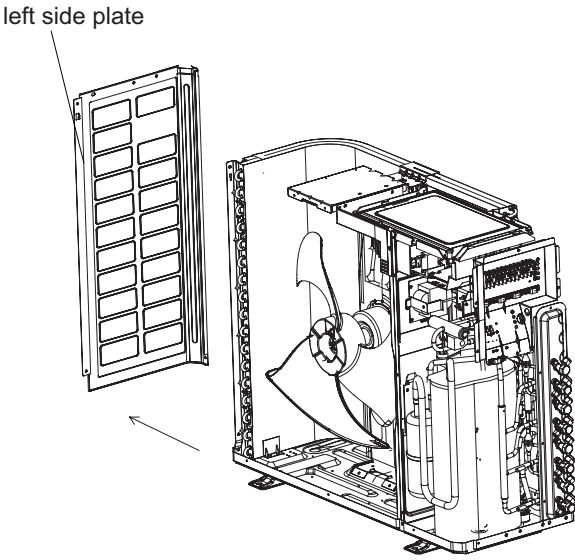
Steps	Procedure	
3	<p>Remove the 5 screws connecting the panel with the chassis and the motor support, and then remove the panel.</p>	 <p>panel</p>
3. Remove right side plate and left side plate		
1	<p>Remove the screws connecting the right side plate with the chassis, the valve support and the electric box, and then remove the right side plate assy.</p>	 <p>right side plate</p>
2	<p>Remove the screws connecting the left side plate and the chassis, and then remove the left side plate assy.</p>	 <p>left side plate</p>

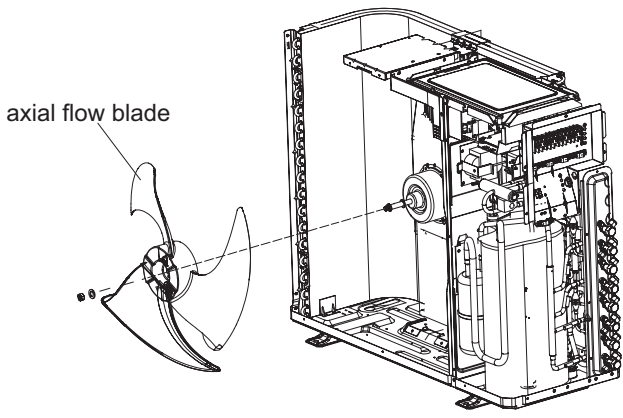
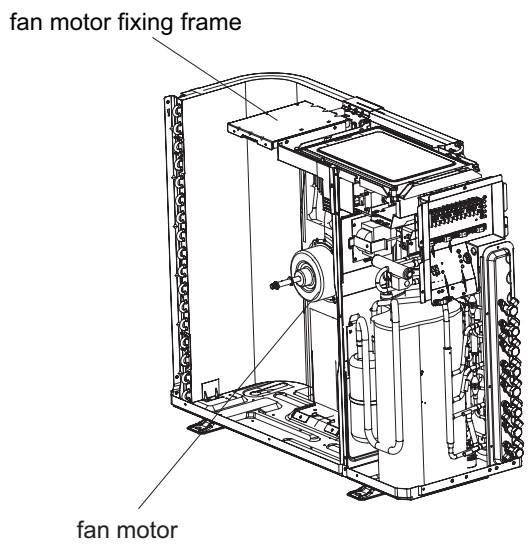
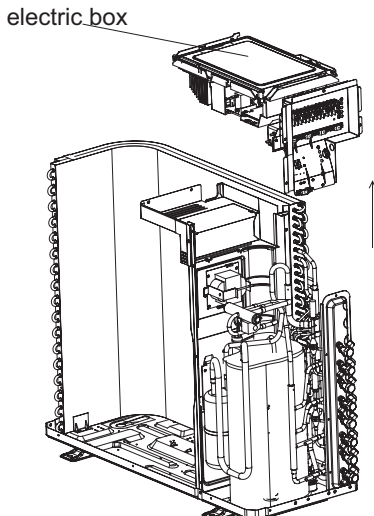
Steps	Procedure	
4. Remove fan motor and axial flow blade		
1	Remove the nuts fixing the blade and then remove the axial flow blade.	 <p>axial flow blade</p>
2	Remove the 4 tapping screws fixing the motor; disconnect the leading wire insert of the motor and then remove the motor. Remove the 2 tapping screws fixing the motor support and then pull the motor support upwards to remove it.	 <p>fan motor fixing frame</p> <p>fan motor</p>
5. Remove electric box		
	Remove the screws fixing the electric box sub-assy; loosen the wire bundle; pull out the wiring terminals and then pull the electric box upwards to remove it.	 <p>electric box</p>

Steps	Procedure
<p>6.Remove soundproof sponge and 4-way valve assy</p>	
<p>1</p>	<p>Since the piping ports on the soundproof sponge are torn easily, remove the soundproof sponge carefully</p>
<p>2</p>	<p>Discharge the refrigerant completely;unsolder the pipelines connecting the compressor and the condenser assy,and then remove the 4-way valve assy.</p>
<p>7. Remove Isolation sheet</p>	
<p></p>	<p>Remove the 3 screws fixing the isolation sheet and then remove the Isolation sheet.</p>

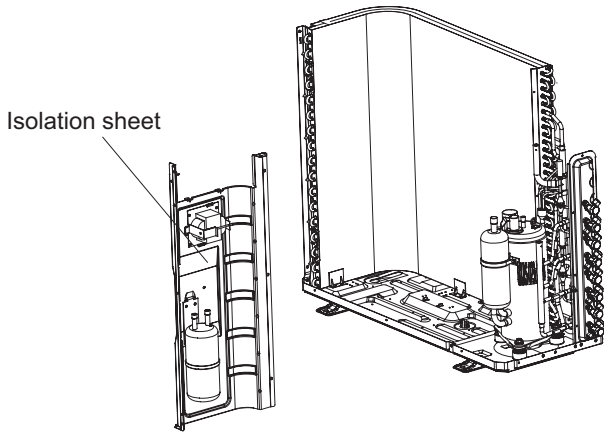
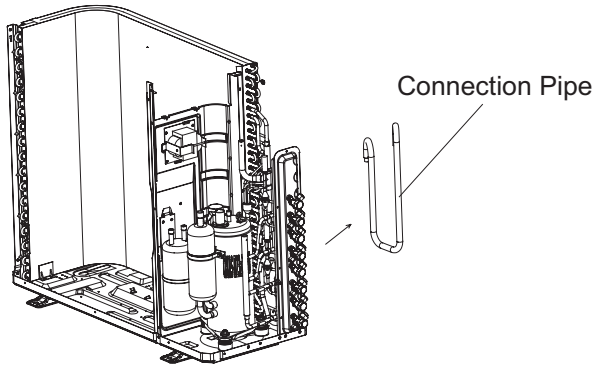
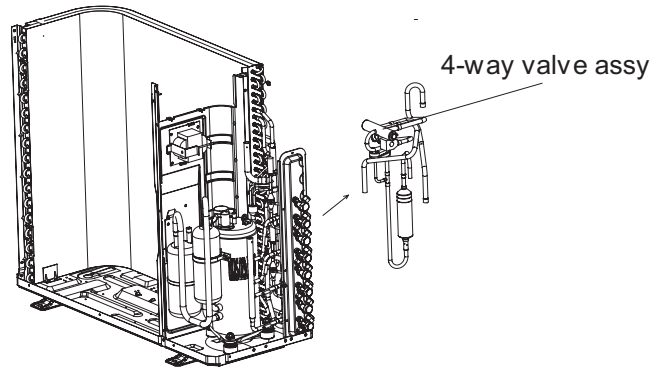
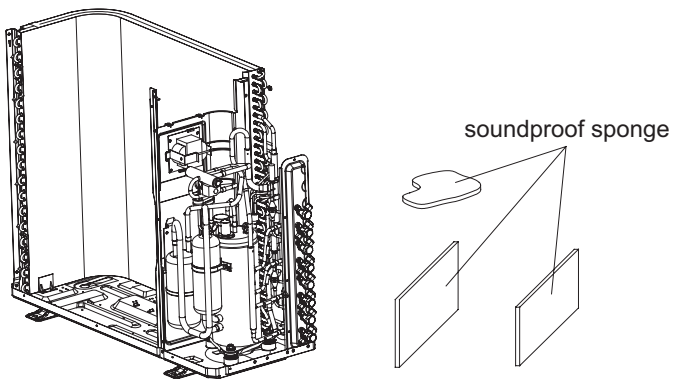

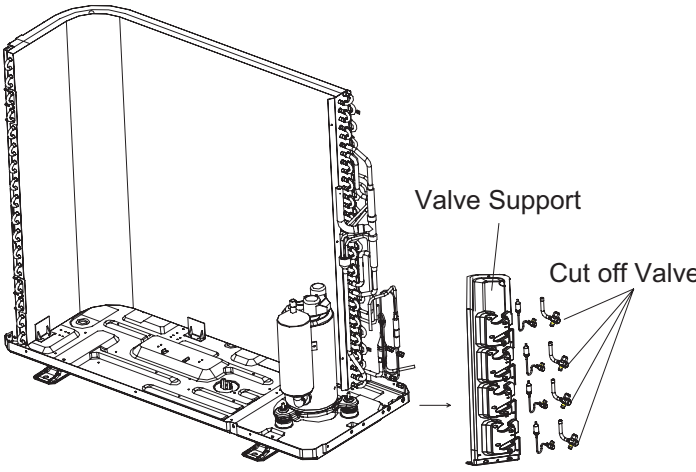
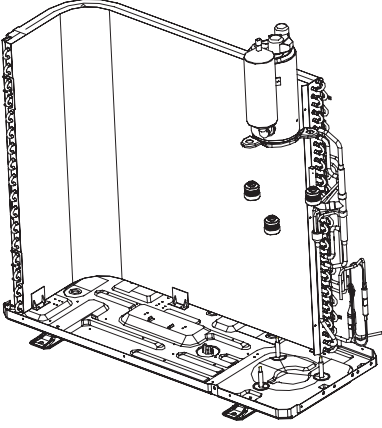
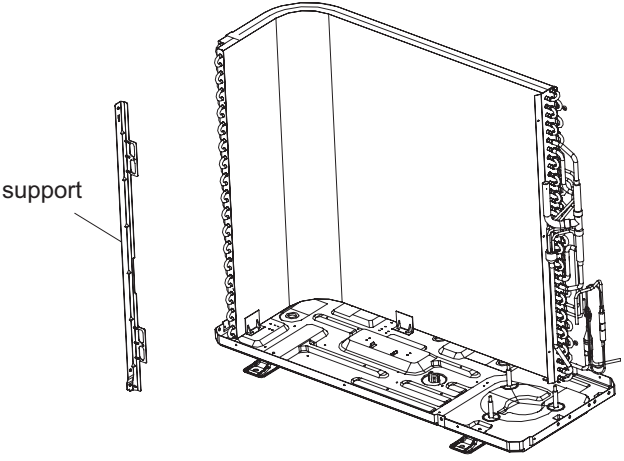
Steps	Procedure	
<p>8. Remove Cut off Valve and Valve Support</p>	<p>Remove the 2 bolts fixing the valve subassemblies. Unsolder the welding joint connecting the gas valve and the return air pipe. Remove the gas valve. (Note: When unsoldering the soldering joint, wrap the gas valve with wet cloth completely to avoid damage to the valve caused by high temperature.) Unsolder the welding joint connecting the liquid valve and the connecting pipe. Remove the liquid valve. Remove screws fixing valve support and then remove the valve support; remove the screw fixing the condenser and then pull the condenser upwards to remove it.</p>	
<p>9. Remove compressor</p>	<p>Remove the 3 foot nuts fixing the compressor and then remove the compressor.</p>	
<p>10. Remove support</p>	<p>1 Remove the screws connecting the support and condenser assy, and then remove the support.</p>	

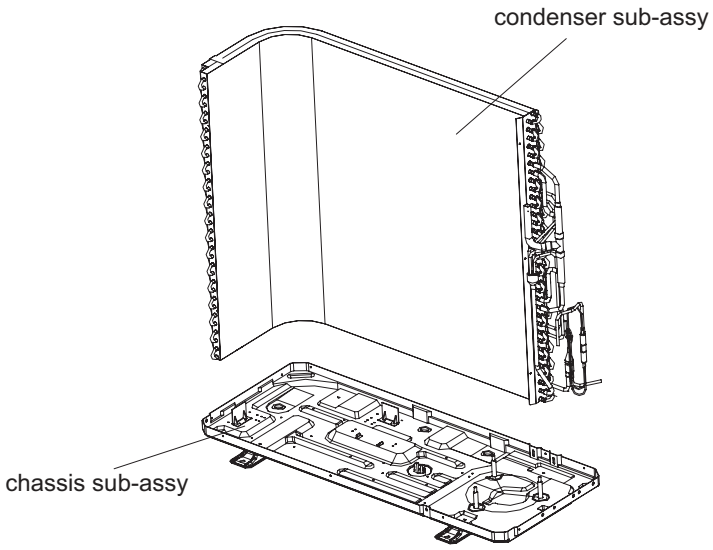
Steps		
11.Remove condenser sub-assy		
	<p>Remove the chassis sub-assy and condenser sub-assy.</p>	 <p>The diagram illustrates the removal of two sub-assemblies from a unit. At the top, the 'condenser sub-assy' is shown as a vertical component with a coil of tubes and electrical connections. Below it, the 'chassis sub-assy' is shown as a flat, rectangular base plate with various mounting points and components. Lines from the labels point to their respective parts in the diagram.</p>

(3) Models: GWHD(36)NK3BO,GWHD(42)NK3AO

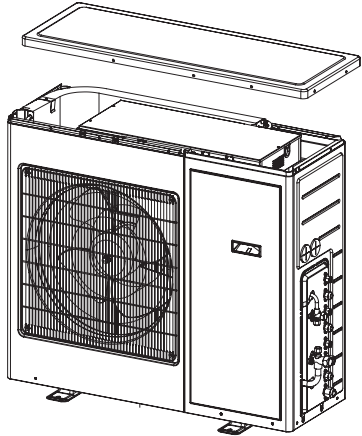
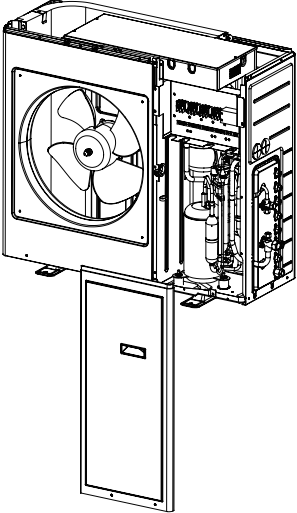
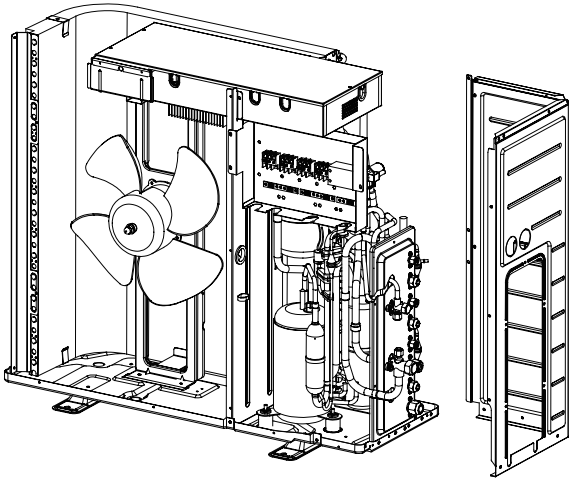
Disassembly and Assembly of Outer Casing	
Steps	Procedure
1. Disassemble the cover plate	 <p>① Remove the fixed screws on the cover plate by using a screwdriver. ② Remove the cover plate.</p>
2. Disassemble the front panel	 <p>① Remove the fixed screws on the front panel by using a screwdriver. ② Remove the front panel.</p>
3. Disassemble the panel on the right side	 <p>① Remove the fixed screws on the panel by using a screwdriver. ② Remove the panel on the right side.</p>

Steps	Procedure
<p>4. Dismount the grille</p>	<div data-bbox="240 519 776 607" data-label="List-Group"> <ul style="list-style-type: none"> ① Remove the fixed screws on the grille by using a screwdriver. ② Remove the grille. </div> <div data-bbox="1068 301 1432 760" data-label="Image"> <p>A technical line drawing of a rectangular unit. The front panel is partially open, revealing a fan inside. A separate grille with a grid pattern is shown below the unit, indicating it has been removed from the front.</p> </div>
<p>5. Disassemble the outer casing</p>	<div data-bbox="240 1092 792 1179" data-label="List-Group"> <ul style="list-style-type: none"> ① Remove the fixed screws on the outer casing by using a screwdriver. ② Remove the outer casing. </div> <div data-bbox="906 812 1399 1371" data-label="Image"> <p>A technical line drawing of the unit with the front grille removed. The outer casing is shown being lifted away from the main body of the unit, revealing the internal fan and other components.</p> </div>
<p>6. Disassemble the fan blades</p>	<div data-bbox="240 1690 776 1777" data-label="List-Group"> <ul style="list-style-type: none"> ① Remove the fixed screws on the fan blades by using a spanner. ② Remove the fan blades. </div> <div data-bbox="912 1432 1448 1961" data-label="Image"> <p>A detailed technical line drawing of the internal fan assembly. The fan blades are shown being detached from the central motor hub. The motor and its mounting frame are clearly visible.</p> </div>

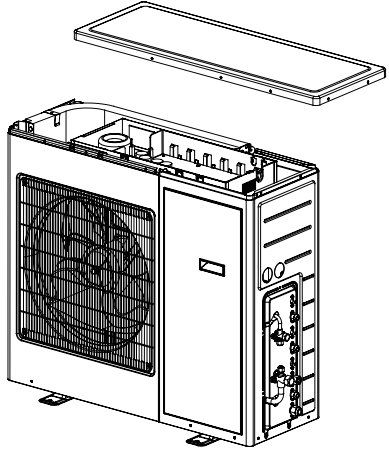
Steps	Procedure
7. Assemble the disassembled main parts as per the reverse disassembly order mentioned above	
Assemble the disassembled main parts as per the reverse disassembly order mentioned above and energize the unit for trial test.	

Disassembly and Assembly of Compressor

Remark: Make sure that there is no refrigerant in pipe system and the power supply is cut off before disassembling the compressor.

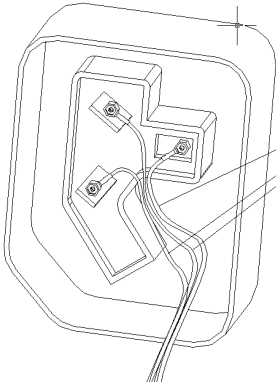
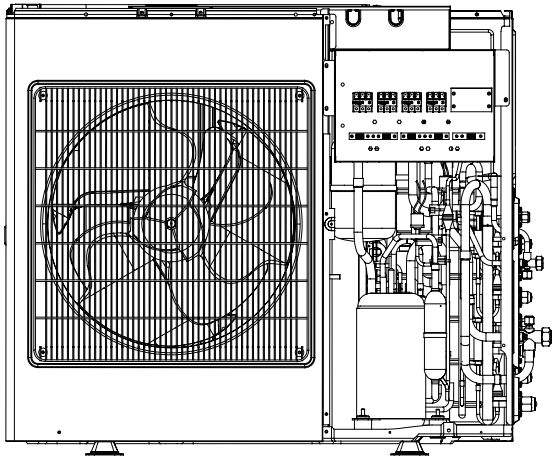
Steps	Procedure
1. Disconnect the power cord	
<p>① Remove the fixed screws on the power cord by using a screwdriver.</p> <p>② Draw out the power cord;</p> <p>Note: Please note the color of each power cord and also the corresponding terminal number when removing the power cord in case of misconnection.</p>	 <p>Note the colour of each power cord and also the corresponding terminal</p>
2. Disassemble the pipeline connected with compressor	
Disconnect the pipeline connected with compressor.	

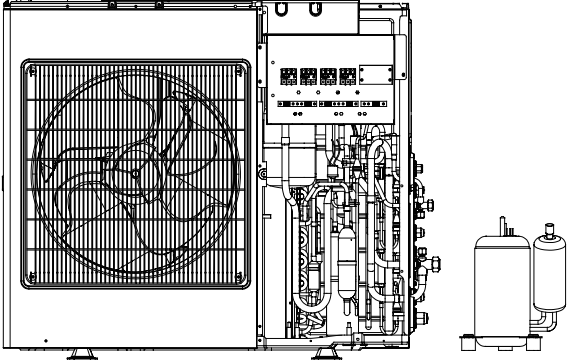
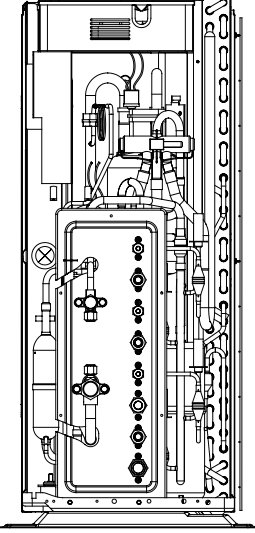
Steps	Procedure
<p>3. Take down the bad compressor</p>	<p>① Remove the bolts on the compressor by using a tool. ② Take down the bad compressor from the bottom plate.</p> 
<p>4. Place the new compressor on the bottom plate and connect the suction inlet and discharge outlet with the pipe system</p>	<p>① Place the compressor on the bottom plate. ② Tighten the nuts by using a tool.</p> 

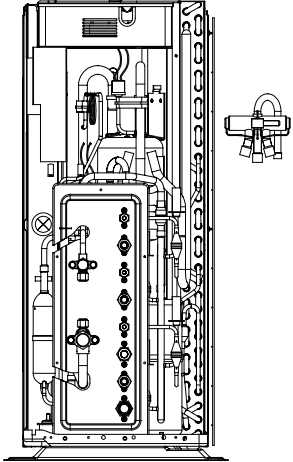
Disassembly and Assembly of 4-way Valve	
Steps	Procedure
<p>1. Remove the 4-way valve coil</p>	<p>① Remove the screws on the fixed coil by using a screwdriver. ② Remove the 4-way valve coil.</p> 

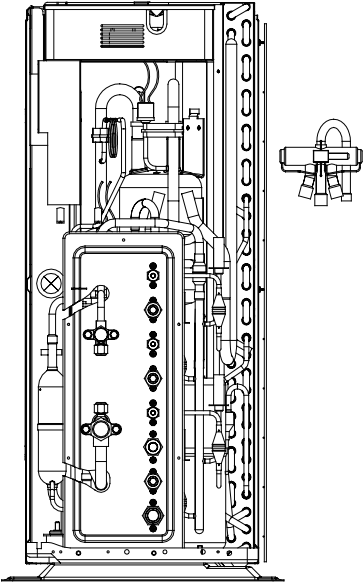
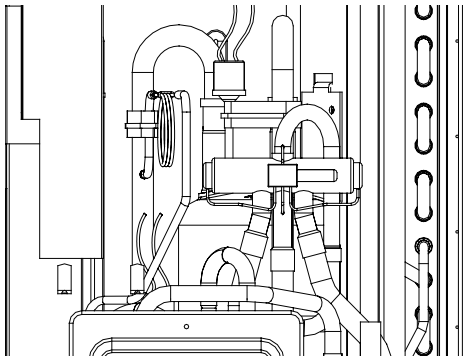
Steps	Procedure	
2. Disconnect the 4-way valve and the connected pipe by soldering. Take down the bad 4-way valve.		
	<p>Disconnect the 4-way valve and the connected pipe by a welding gun. Take down the bad 4-way valve.</p>	
3. Replace the 4-way valve and reconnect it with the pipeline.		
	<ol style="list-style-type: none"> ① Place the new 4-way valve in the right place. ② Rewelding the new 4-way valve with the pipeline. 	
4. Install the 4-way valve coil		
	<ol style="list-style-type: none"> ① Set the 4-way valve coil soundly. ② Tighten the screws by a screwdriver. 	

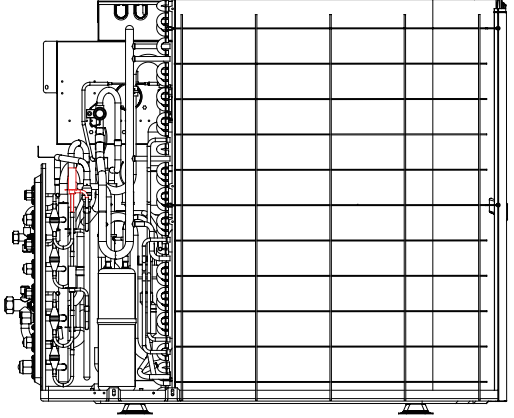
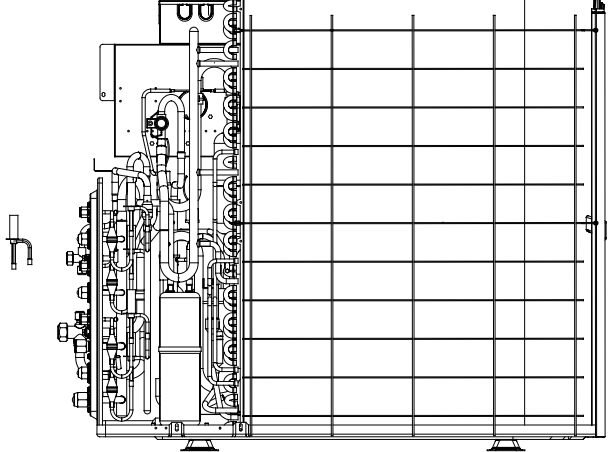
Disassembly and Assembly of Electronic Expansion Valve	
Steps	Procedure
1. Remove the electronic expansion valve coil	
Remove the electronic expansion valve coil by rotating it until the lock is unfixed.	
2. Disconnect the electronic expansion valve and the connected pipe by soldering	
Disconnect the electronic expansion valve and the connected pipe by a welding gun.	
3. Replace the electronic expansion valve	
Place the new electronic expansion valve in the right place.	
4. Reconnect the electronic expansion valve with the pipeline	
Reconnect the electronic expansion valve with the pipeline by welding.	
5. Install the electronic expansion valve coil	
Set the electronic expansion valve coil on the valve body and adjust the lock to the right place.	

Disassembly and Assembly of Vapour Liquid Separator

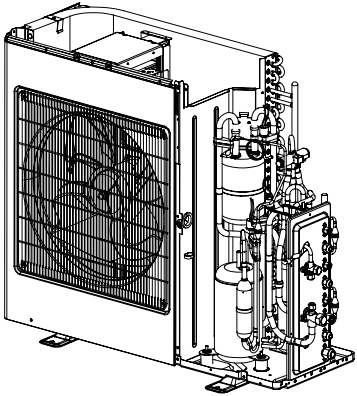
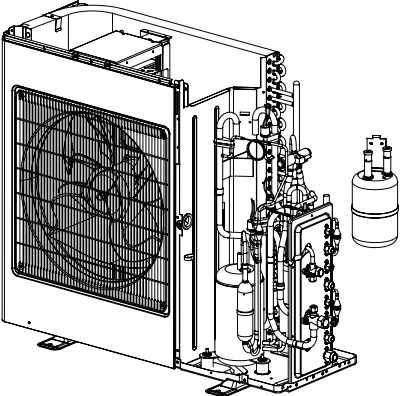
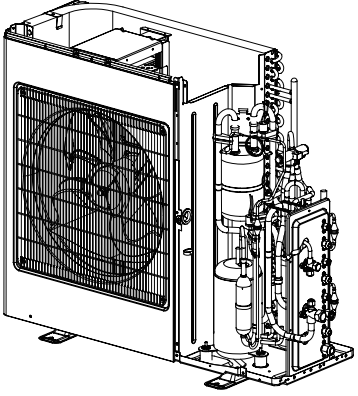
Steps	Procedure
1. Disconnect the liquid separator and the connected pipeline	<p data-bbox="240 600 779 666">Disconnect the liquid separator and the connected pipeline.</p> 
2. Remove the liquid separator	<p data-bbox="240 1146 820 1212">① Remove the bolt fixing the liquid separator by a tool. ② Remove the liquid separator from the middle baffle.</p> 
3. Fix the new liquid separator and connect it with the pipeline	<p data-bbox="240 1714 787 1823">① Fix the new liquid separator on the middle baffle soundly. ② Tighten the bolt by tool and reconnect the new liquid separator with the pipeline by welding.</p> 

Appendix:

Appendix 1: Reference Sheet of Celsius and Fahrenheit

Conversion formula for Fahrenheit degree and Celsius degree: $T_f = T_c \times 1.8 + 32$

Set temperature

Fahrenheit display temperature (°F)	Fahrenheit (°F)	Celsius (°C)	Fahrenheit display temperature (°F)	Fahrenheit (°F)	Celsius (°C)	Fahrenheit display temperature (°F)	Fahrenheit (°F)	Celsius (°C)
61	60.8	16	69/70	69.8	21	78/79	78.8	26
62/63	62.6	17	71/72	71.6	22	80/81	80.6	27
64/65	64.4	18	73/74	73.4	23	82/83	82.4	28
66/67	66.2	19	75/76	75.2	24	84/85	84.2	29
68	68	20	77	77	25	86	86	30

Ambient temperature

Fahrenheit display temperature (°F)	Fahrenheit (°F)	Celsius (°C)	Fahrenheit display temperature (°F)	Fahrenheit (°F)	Celsius (°C)	Fahrenheit display temperature (°F)	Fahrenheit (°F)	Celsius (°C)
32/33	32	0	55/56	55.4	13	79/80	78.8	26
34/35	33.8	1	57/58	57.2	14	81	80.6	27
36	35.6	2	59/60	59	15	82/83	82.4	28
37/38	37.4	3	61/62	60.8	16	84/85	84.2	29
39/40	39.2	4	63	62.6	17	86/87	86	30
41/42	41	5	64/65	64.4	18	88/89	87.8	31
43/44	42.8	6	66/67	66.2	19	90	89.6	32
45	44.6	7	68/69	68	20	91/92	91.4	33
46/47	46.4	8	70/71	69.8	21	93/94	93.2	34
48/49	48.2	9	72	71.6	22	95/96	95	35
50/51	50	10	73/74	73.4	23	97/98	96.8	36
52/53	51.8	11	75/76	75.2	24	99	98.6	37
54	53.6	12	77/78	77	25			

Appendix 2: Configuration of Connection Pipe

- Standard length of connection pipe
 - 16.4ft, 24.6ft, 26.2ft.
- Min. length of connection pipe is 9.84ft.
- Max. length of connection pipe and max. high difference.
- The additional refrigerant oil and refrigerant charging required after prolonging connection pipe
 - After the length of connection pipe is prolonged for 32.8ft at the basis of standard length, you should add 5ml of refrigerant oil for each additional 16.4ft of connection pipe.
 - The calculation method of additional refrigerant charging amount (on the basis of liquid pipe):
 - When the length of connection pipe is above 16.4ft, add refrigerant according to the prolonged length of liquid pipe. The additional refrigerant charging amount per meter is different according to the diameter of liquid pipe. See the following sheet.
 - Additional refrigerant charging amount = prolonged length of liquid pipe X additional refrigerant charging amount per meter

Cooling capacity	Max length of connection pipe	Max height difference
5000 Btu/h(1465 W)	49.2 ft	16.4 ft
7000 Btu/h(2051 W)	49.2 ft	16.4 ft
9000 Btu/h(2637 W)	49.2 ft	32.8 ft
12000 Btu/h(3516 W)	65.6 ft	32.8 ft
18000 Btu/h(5274 W)	82.0 ft	32.8 ft
24000 Btu/h(7032 W)	82.0 ft	32.8 ft
28000 Btu/h(8204 W)	98.4 ft	32.8 ft
36000 Btu/h(10548 W)	98.4 ft	65.6 ft
42000 Btu/h(12306 W)	98.4 ft	65.6 ft
48000 Btu/h(14064 W)	98.4 ft	65.6 ft

Additional refrigerant charging amount for R22, R407C, R410A and R134a			
Diameter of connection pipe		Outdoor unit throttle	
Liquid pipe(inch)	Gas pipe(inch)	Cooling only(oz/ft)	Cooling and heating(oz/ft)
Φ0.23	Φ0.37 or Φ0.47	0.53	0.71
Φ0.23 or Φ0.37	Φ0.63 or Φ0.75	0.53	0.71
Φ0.47	Φ0.75 or Φ0.84	1.06	4.23
Φ0.63	Φ1.0 or Φ1.25	2.12	4.23
Φ0.75	/	8.82	8.11
Φ0.84	/	12.34	12.34

Appendix 3: Pipe Expanding Method

⚠ Note:

Improper pipe expanding is the main cause of refrigerant leakage. Please expand the pipe according to the following steps:

A: Cut the pip

- Confirm the pipe length according to the distance of indoor unit and outdoor unit.
- Cut the required pipe with pipe cutter.

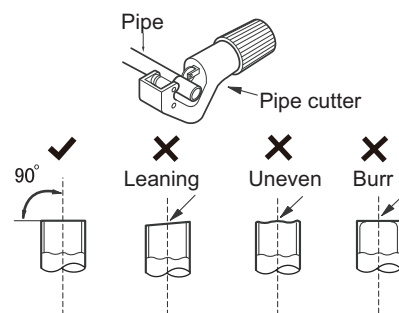

B: Remove the burrs

- Remove the burrs with shaper and prevent the burrs from getting into the pipe.

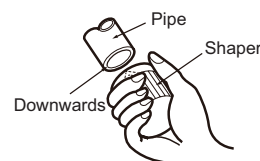

C: Put on suitable insulating pipe

D: Put on the union nut

- Remove the union nut on the indoor connection pipe and outdoor valve; install the union nut on the pipe.

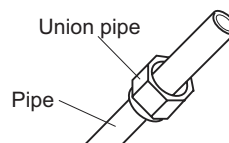

E: Expand the port

- Expand the port with expander.

⚠ Note:

- "A" is different according to the diameter, please refer to the sheet below:

Outer diameter(inch)	A(inch)	
	Max	Min
Φ0.23 - 0.25 (1/4")	0.051	0.028
Φ9.52 (3/8")	0.063	0.039
Φ0.37 - 0.5 (1/2")	0.071	0.039
Φ0.63 (5/8")	0.095	0.087

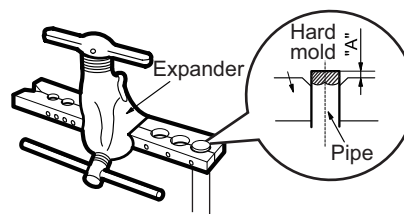

F: Inspection

- Check the quality of expanding port. If there is any blemish, expand the port again according to the steps above.

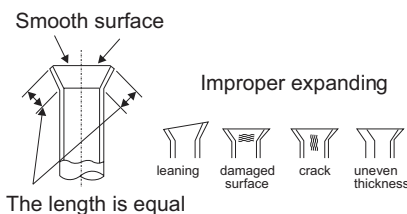

Appendix 4: List of Resistance for Ambient Temperature Sensor

Resistance Table of Ambient Temperature Sensor for Indoor and Outdoor Units(15K)

Temp(°C)	Resistance(kΩ)	Temp(°C)	Resistance(kΩ)	Temp(°C)	Resistance(kΩ)	Temp(°C)	Resistance(kΩ)
-19	138.1	20	18.75	59	3.848	98	1.071
-18	128.6	21	17.93	60	3.711	99	1.039
-17	121.6	22	17.14	61	3.579	100	1.009
-16	115	23	16.39	62	3.454	101	0.98
-15	108.7	24	15.68	63	3.333	102	0.952
-14	102.9	25	15	64	3.217	103	0.925
-13	97.4	26	14.36	65	3.105	104	0.898
-12	92.22	27	13.74	66	2.998	105	0.873
-11	87.35	28	13.16	67	2.896	106	0.848
-10	82.75	29	12.6	68	2.797	107	0.825
-9	78.43	30	12.07	69	2.702	108	0.802
-8	74.35	31	11.57	70	2.611	109	0.779
-7	70.5	32	11.09	71	2.523	110	0.758
-6	66.88	33	10.63	72	2.439	111	0.737
-5	63.46	34	10.2	73	2.358	112	0.717
-4	60.23	35	9.779	74	2.28	113	0.697
-3	57.18	36	9.382	75	2.206	114	0.678
-2	54.31	37	9.003	76	2.133	115	0.66
-1	51.59	38	8.642	77	2.064	116	0.642
0	49.02	39	8.297	78	1.997	117	0.625
1	46.6	40	7.967	79	1.933	118	0.608
2	44.31	41	7.653	80	1.871	119	0.592
3	42.14	42	7.352	81	1.811	120	0.577
4	40.09	43	7.065	82	1.754	121	0.561
5	38.15	44	6.791	83	1.699	122	0.547
6	36.32	45	6.529	84	1.645	123	0.532
7	34.58	46	6.278	85	1.594	124	0.519
8	32.94	47	6.038	86	1.544	125	0.505
9	31.38	48	5.809	87	1.497	126	0.492
10	29.9	49	5.589	88	1.451	127	0.48
11	28.51	50	5.379	89	1.408	128	0.467
12	27.18	51	5.197	90	1.363	129	0.456
13	25.92	52	4.986	91	1.322	130	0.444
14	24.73	53	4.802	92	1.282	131	0.433
15	23.6	54	4.625	93	1.244	132	0.422
16	22.53	55	4.456	94	1.207	133	0.412
17	21.51	56	4.294	95	1.171	134	0.401
18	20.54	57	4.139	96	1.136	135	0.391
19	19.63	58	3.99	97	1.103	136	0.382

Resistance Table of Ambient Temperature Sensor for Indoor and Outdoor Units(20K)

Temp(°C)	Resistance(kΩ)	Temp(°C)	Resistance(kΩ)	Temp(°C)	Resistance(kΩ)	Temp(°C)	Resistance(kΩ)
-19	181.4	20	25.01	59	5.13	98	1.427
-18	171.4	21	23.9	60	4.948	99	1.386
-17	162.1	22	22.85	61	4.773	100	1.346
-16	153.3	23	21.85	62	4.605	101	1.307
-15	145	24	20.9	63	4.443	102	1.269
-14	137.2	25	20	64	4.289	103	1.233
-13	129.9	26	19.14	65	4.14	104	1.198
-12	123	27	18.13	66	3.998	105	1.164
-11	116.5	28	17.55	67	3.861	106	1.131
-10	110.3	29	16.8	68	3.729	107	1.099
-9	104.6	30	16.1	69	3.603	108	1.069
-8	99.13	31	15.43	70	3.481	109	1.039
-7	94	32	14.79	71	3.364	110	1.01
-6	89.17	33	14.18	72	3.252	111	0.983
-5	84.61	34	13.59	73	3.144	112	0.956
-4	80.31	35	13.04	74	3.04	113	0.93
-3	76.24	36	12.51	75	2.94	114	0.904
-2	72.41	37	12	76	2.844	115	0.88
-1	68.79	38	11.52	77	2.752	116	0.856
0	65.37	39	11.06	78	2.663	117	0.833
1	62.13	40	10.62	79	2.577	118	0.811
2	59.08	41	10.2	80	2.495	119	0.77
3	56.19	42	9.803	81	2.415	120	0.769
4	53.46	43	9.42	82	2.339	121	0.746
5	50.87	44	9.054	83	2.265	122	0.729
6	48.42	45	8.705	84	2.194	123	0.71
7	46.11	46	8.37	85	2.125	124	0.692
8	43.92	47	8.051	86	2.059	125	0.674
9	41.84	48	7.745	87	1.996	126	0.658
10	39.87	49	7.453	88	1.934	127	0.64
11	38.01	50	7.173	89	1.875	128	0.623
12	36.24	51	6.905	90	1.818	129	0.607
13	34.57	52	6.648	91	1.736	130	0.592
14	32.98	53	6.403	92	1.71	131	0.577
15	31.47	54	6.167	93	1.658	132	0.563
16	30.04	55	5.942	94	1.609	133	0.549
17	28.68	56	5.726	95	1.561	134	0.535
18	27.39	57	5.519	96	1.515	135	0.521
19	26.17	58	5.32	97	1.47	136	0.509

Resistance Table of Ambient Temperature Sensor for Indoor and Outdoor Units(50K)

Temp(°C)	Resistance(kΩ)	Temp(°C)	Resistance(kΩ)	Temp(°C)	Resistance(kΩ)	Temp(°C)	Resistance(kΩ)
-29	853.5	10	98	49	18.34	88	4.75
-28	799.8	11	93.42	50	17.65	89	4.61
-27	750	12	89.07	51	16.99	90	4.47
-26	703.8	13	84.95	52	16.36	91	4.33
-25	660.8	14	81.05	53	15.75	92	4.20
-24	620.8	15	77.35	54	15.17	93	4.08
-23	580.6	16	73.83	55	14.62	94	3.96
-22	548.9	17	70.5	56	14.09	95	3.84
-21	516.6	18	67.34	57	13.58	96	3.73
-20	486.5	19	64.33	58	13.09	97	3.62
-19	458.3	20	61.48	59	12.62	98	3.51
-18	432	21	58.77	60	12.17	99	3.41
-17	407.4	22	56.19	61	11.74	100	3.32
-16	384.5	23	53.74	62	11.32	101	3.22
-15	362.9	24	51.41	63	10.93	102	3.13
-14	342.8	25	49.19	64	10.54	103	3.04
-13	323.9	26	47.08	65	10.18	104	2.96
-12	306.2	27	45.07	66	9.83	105	2.87
-11	289.6	28	43.16	67	9.49	106	2.79
-10	274	29	41.34	68	9.17	107	2.72
-9	259.3	30	39.61	69	8.85	108	2.64
-8	245.6	31	37.96	70	8.56	109	2.57
-7	232.6	32	36.38	71	8.27	110	2.50
-6	220.5	33	34.88	72	7.99	111	2.43
-5	209	34	33.45	73	7.73	112	2.37
-4	198.3	35	32.09	74	7.47	113	2.30
-3	199.1	36	30.79	75	7.22	114	2.24
-2	178.5	37	29.54	76	7.00	115	2.18
-1	169.5	38	28.36	77	6.76	116	2.12
0	161	39	27.23	78	6.54	117	2.07
1	153	40	26.15	79	6.33	118	2.02
2	145.4	41	25.11	80	6.13	119	1.96
3	138.3	42	24.13	81	5.93	120	1.91
4	131.5	43	23.19	82	5.75	121	1.86
5	125.1	44	22.29	83	5.57	122	1.82
6	119.1	45	21.43	84	5.39	123	1.77
7	113.4	46	20.6	85	5.22	124	1.73
8	108	47	19.81	86	5.06	125	1.68
9	102.8	48	19.06	87	4.90	126	1.64

JF00301806



GREE ELECTRIC APPLIANCES, INC. OF ZHUHAI

Add: West Jinji Rd, Qianshan, Zhuhai, Guangdong, China 519070

Tel: (+86-756) 8522218 Fax: (+86-756) 8669426

Email: gree@gree.com.cn Http://www.gree.com

HONG KONG GREE ELECTRIC APPLIANCES SALES LIMITED

Add: Unit 2612, 26/F., Miramar Tower 132 Nathan Road, TST, Kowloon, HK

Tel: (852) 31658898 Fax: (852) 31651029

For product improvement, specifications and appearance in this manual are subject to change without prior notice.